



Version	0.4
Total pages	22
Date	2007.03.16

Product Specification

7" color TFT-LCD module

MODEL NAME: A070FW03 V7

- (◆) Preliminary Specification
- (.....) Final Specification

Note: The content of this specification is subject to change.

© 2006 AU Optronics
All Rights Reserved,
Do Not Copy.



Contents:

A. Physical specification..... P3

B. Electrical specifications..... P4

 1. Pin assignment..... **P4**

 a. TFT-LCD panel driving section..... **P4**

 b. Backlight driving section..... **P5**

 2. Absolute maximum ratings..... **P6**

 3. Electrical characteristics..... **P7**

 a. Typical operating conditions..... **P7**

 b. Current consumption..... **P7**

 c. Backlight driving conditions..... **P7**

 4. AC Timing..... **P8**

 a. Timing conditions..... **P8**

 b. Timing diagram..... **P8**

 5. Power Sequence..... **P9**

C. Optical specifications..... P10

D. Reliability test items..... P12

E. Packing form..... P13

Appendix:

Fig.1-(a) Outline dimension of TFT-LCD module. **P14**
Fig.1-(b) Outline dimension of TFT-LCD module. **P15**
Fig.2 Sampling clock timing. **P16**
Fig.3 Horizontal display timing range. **P17**
Fig.4-(a) Horizontal timing. **P18**
Fig.4-(b) Detail horizontal timing. **P19**
Fig.5 Vertical shift clock timing. **P20**
Fig.6-(a) Vertical timing (From up to down). **P21**
Fig.6-(b) Vertical timing (From down to up) **P22**

A. Physical specifications

NO.	Item	Specification	Remark
1	Display resolution (dot)	1440(W)×234(H)	
2	Active area (mm)	154.08(W)×86.58(H)	
3	Screen size (inch)	7.0(Diagonal)	
4	Dot pitch (mm)	0.107(W)×0.370(H)	
5	Color configuration	R. G. B. stripe	Note 1
6	Overall dimension (mm)	164.9 (W)×100(H)×5.7(D)	Note 2
7	Weight (g)	153.5	
8	Surface treatment	AG (25%)	
9	Backlight unit	LED	

Note 1: Below figure shows the dot stripe arrangement.

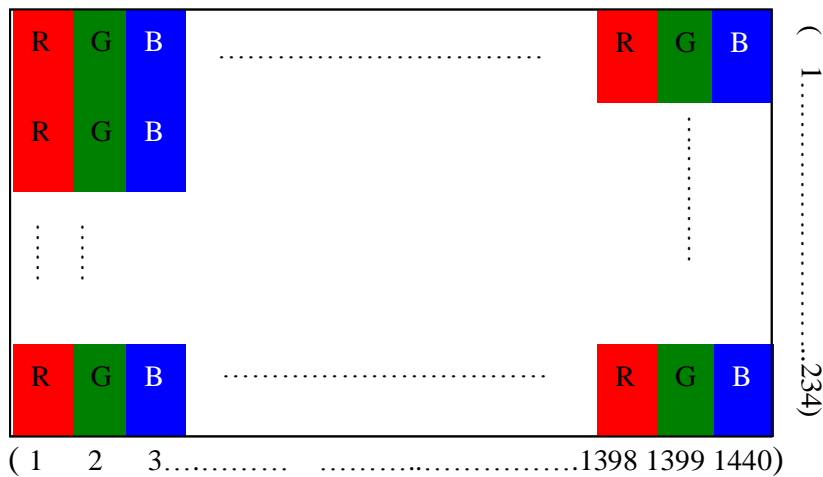

Note 2: Refer to Fig. 1

B. Electrical specifications

1.Pin assignment

a. TFT-LCD panel driving section

Pin no	Symbol	I/O	Description	Remark
1	GND	-	Ground for logic circuit	
2	V _{CC}	I	Supply voltage of logic control circuit for scan driver	
3	V _{GL}	I	Negative power for scan driver	
4	V _{GH}	I	Positive power for scan driver	
5	STVR	I/O	Vertical start pulse	Note 1
6	STVL	I/O	Vertical start pulse	Note 1
7	CKV	I	Shift clock input for scan driver	
8	U/D	I	UP/DOWN scan control input	Note 1,2
9	OEV	I	Output enable input for scan driver	
10	VCOM	I	Common electrode driving signal	
11	VCOM	I	Common electrode driving signal	
12	L/R	I	LEFT/RIGHT scan control input	Note 1,2
13	MOD	I	Sequential sampling and simultaneous sampling setting	Note 3
14	OEH	I	Output enable input for data driver	
15	STHL	I/O	Start pulse for horizontal scan line	Note 1
16	STHR	I/O	Start pulse for horizontal scan line	Note 1
17	CPH3	I	Sampling and shifting clock pulse for data driver	
18	CPH2	I	Sampling and shifting clock pulse for data driver	
19	CPH1	I	Sampling and shifting clock pulse for data driver	
20	V _{CC}	I	Supply voltage of logic control circuit for data driver	
21	GND	-	Ground for logic circuit	
22	VR	I	Alternated video signal input(Red)	
23	VG	I	Alternated video signal input(Green)	
24	VB	I	Alternated video signal input(Blue)	
25	AV _{DD}	I	Supply voltage for analog circuit	

26	AV _{SS}	-	Ground for analog circuit	
----	------------------	---	---------------------------	--

Note 1: Selection of scanning mode (please refer to the following table)

Setting of scan control input		IN/OUT state for start pulse				Scanning direction
U/D	L/R	STVR	STVL	STHR	STHL	
GND	V _{CC}	OUT	IN	OUT	IN	From up to down, and from left to right.
V _{CC}	GND	IN	OUT	IN	OUT	From down to up, and from right to left.
GND	GND	OUT	IN	IN	OUT	From up to down, and from right to left.
V _{CC}	V _{CC}	IN	OUT	OUT	IN	From down to up, and from left to right.

IN: Input; OUT: Output.

Note 2: Definition of scanning direction.

Refer to figure as below:

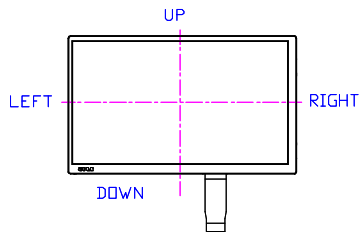

Note 3: MOD = H: Simultaneous sampling.

MOD = L: Sequential sampling.

Please set CPH2 and CPH3 to GND when MOD = H.

b. Backlight driving section (Refer to Figure 1)

No.	Symbol	I/O	Description	Remark
1	HI	I	Power supply for backlight unit (High voltage)	--
2	GND	-	Ground for backlight unit	--

2. Absolute maximum ratings

Item	Symbol	Condition	Min.	Max.	Unit	Remark
Power voltage	V_{CC}	GND=0	-0.3	7	V	
	AV_{DD}	$AV_{SS}=0$	-0.3	7	V	
	V_{GH}	GND=0	-0.3	18	V	
	V_{GL}		-15	0.3	V	
	$V_{GH}-V_{GL}$		-	33	V	
Input signal voltage	V_i		-0.3	$AV_{DD}+0.3$	V	Note 1
	V_l		-0.3	$V_{CC}+0.3$	V	Note 2
	VCOM		-2.9	5.2	V	
Storage Temperature	Tstg		-30	+85	°C	Note 3
Operation Temperature	Top	Surface	-20	+70	°C	Note 3,4
LED Max. Rating Current	I_{LED}			25	mA	

Note 1: VR, VG, VB.

Note 2: STHL, STHR, OEH, L/R, CPH1~CPH3, STVR, STVL, OEV, CKV, U/D.

Note 3: The temperature of panel surface must not exceed this rating

Note 4: The operating temperature assures only driving. Contrast, response time, the other display quality is judgment at 25°C.

3. Electrical characteristics

a. Typical operating conditions (GND=AVss=0V, Note 4)

Item	Symbol	Min.	Typ.	Max.	Unit	Remark
Power supply	V _{CC}	3	5	5.5	V	
	AV _{DD}	4.5	5	5.5	V	
	V _{GH}	14.3	15	15.7	V	
	V _{GL}	-10.5	-10	-9.5	V	
Video signal amplitude (VR, VG, VB)	V _{iA}	0.4	-	AV _{DD} -0.4	V	Note 1
	V _{iAC}	-	3	-	V	AC component
	V _{iDC}	-	AV _{DD} /2	-	V	DC component
VCOM	V _{CAC}	3.5	5.6	6.5	Vp-p	AC component, Note 2
	V _{CDC}	1.4	1.7	2.0	V	DC component
Input signal voltage	H Level	V _{IH}	0.8 V _{CC}	-	V _{CC}	Note 3
	L Level	V _{IL}	0	-	0.2 V _{CC}	

Note 1: Refer to Fig.4- (a).

Note 2: Adjusting the AC component of VCOM could change the brightness of LCD panel.

Note 3: STHL, STHR, OEH, L/R, CPH1~CPH3, STVR, STVL, OEV, CKV, U/D.

Note 4: Be sure to apply GND, V_{CC} and V_{GL} to the LCD first, and then apply V_{GH}.

b. Current consumption (GND=AVss=0V)

Parameter	Symbol	Condition	Min.	Typ.	Max.	Unit	Remark
Current for driver	I _{GH}	V _{GH} =15V	-	0.20	0.5	mA	
	I _{GL}	V _{GL} =-10V	-	0.80	1.5	mA	
	I _{CC}	V _{CC} =5V	-	3.0	6.0	mA	
	I _{DD}	AV _{DD} =5V	-	17.0	30	mA	

c. Backlight driving conditions

Parameter	Symbol	Min.	Typ.	Max.	Unit	Remark
LED Lightbar Current	I _L	---	160	---	mA	---
LED Lightbar Voltage	V _L	10	12	12	V	---
LED Life Time	L _L	20,000	---	---	Hr	---

Note 1: LED backlight is 21 pcs of LED lightbar type.

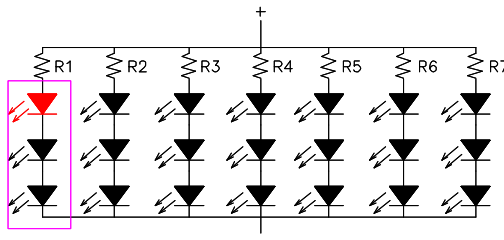

Note 2: Definition of "LED Lifetime": brightness is decreased to 50% of the initial value. LED Lifetime is restricted under normal condition, ambient temperature = 25 °C and LED voltage = 12V.

4. AC Timing

a. Timing conditions

Parameter	Symbol	Min.	Typ.	Max.	Unit.	Remark
Rising time	t_r	-	-	10	ns	Note 1
Falling time	t_f	-	-	10	ns	Note 1
High and low level pulse width	t_{CPH}	99	103	107	ns	CPH1~CPH3
CPH pulse duty	t_{CWH}	40	50	60	%	CPH1~CPH3
CPH pulse delay	t_{C12} t_{C23} t_{C31}	30	$t_{CPH}/3$	$t_{CPH}/2$	ns	CPH1~CPH3
STH setup time	t_{SUH}	20	-	-	ns	STHR,STHL
STH hold time	t_{HDH}	20	-	-	Ns	STHR,STHL
STH pulse width	t_{STH}	-	1	-	t_{CPH}	STHR,STHL
STH period	t_H	61.5	63.5	65.5	μs	STHR,STHL
OEH pulse width	t_{OEH}	-	1.22	-	μs	OEH
Sample and hold disable time	t_{DIS1}	-	8.28	-	μs	
OEV pulse width	t_{OEV}	-	5.40	-	μs	OEV
CKV pulse width	t_{CKV}	-	4.18	-	μs	CKV
Clean enable time	t_{DIS2}	-	3.74	-	μs	
Horizontal display start	t_{SH}	-	0	-	$T_{CPH}/3$	
Horizontal display timing range	t_{DH}	-	1440	-	$T_{CPH}/3$	
STV setup time	t_{SUV}	400	-	-	ns	STVL,STVR
STV hold time	t_{HDV}	400	-	-	ns	STVL,STVR
STV pulse width	t_{STV}	-	-	1	t_H	STVL,STVR
Horizontal lines per field	t_V	256	262	268	t_H	Note 2
Vertical display start	t_{SV}		3	-	t_H	
Vertical display timing range	t_{DV}		234	-	t_H	
VCOM rising time	t_{rCOM}		-	5	μs	
VCOM falling time	t_{fCOM}		-	5	μs	
VCOM delay time	t_{DCOM}		-	3	μs	
RGB delay time	t_{DRGB}		-	1	μs	

Note 1: The values herein are for all of the logic signals.

Note 2: Please don't use odd horizontal lines to drive LCD panel for both odd and even field simultaneously.

b. Timing diagram

Please refer to the attached drawing, from Fig.2 to Fig.6.

5. Power Sequence

Sequence for power on/off and Signal on/off

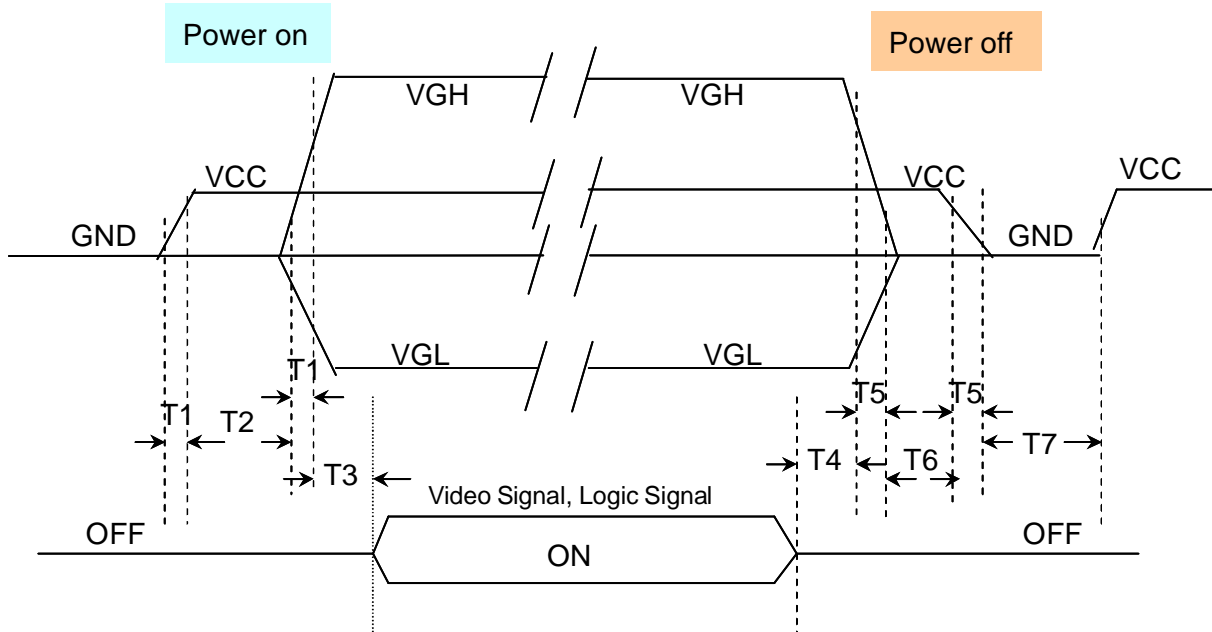

- T1 \cong 15ms (From 10%*VCC to 90%*VCC , when VCC is Low to High) ;
- T2 \cong 10ms (From 90%*VCC to 10%*VGH , when VCC is Low to High) ;
- T3 \cong 10ms (From 90%*VGH to Video signal , when VGH is Low to High) ;
- T4 \cong 10ms (From Video signal to 90%*VGH , when VGH is High to Low) ;
- T5 \cong 20ms (From 90%*VCC to 10%*VCC , when VCC is High to Low) ;
- T6 \cong 10ms (From 10%*VGH to 90%*VCC , when VCC is Low to High) ;
- T7 \cong 0.4s (From 10%*VCC is H→L to 10%*VCC is L→H) °

C. Optical specification (Note 1, Note 2)

Item	Symbol	Condition	Min.	Typ.	Max.	Unit	Remark
Response time	Rise	$\theta = 0^\circ$	-	12	24	ms	Note 3,5
	Fall		-	18	36	ms	
Contrast ratio	CR	At optimized Viewing angle	300	400	-		Note 4, 5
Viewing angle	Top	$CR \geq 10$	30	40	-	deg.	Note 5, 6
	Bottom		50	65	-		
	Left		50	65	-		
	Right		50	65	-		
Brightness	Y_L	$V_L = 12V, 25^\circ C$	200	280	-	cd/m ²	Note 7
White chromaticity	X	$\theta = 0^\circ$	0.28	0.31	0.34		Note 7
	Y	$\theta = 0^\circ$	0.30	0.33	0.36		
Uniformity			75	80	-	%	

Note 1 : Ambient temperature =25 °C . To be measured in the dark room.

Note 2 :To be measured on the center area of panel with a viewing cone of 1 °by Topcon luminance meter BM-5, after 15 minutes operation.

Note 3. Definition of response time:

The output signals of photo detector are measured when the input signals are changed from "black" to "white"(falling time) and from "white" to "black"(rising time), respectively.

The response time is defined as the time interval between the 10% and 90% of amplitudes. Refer to figure as below.

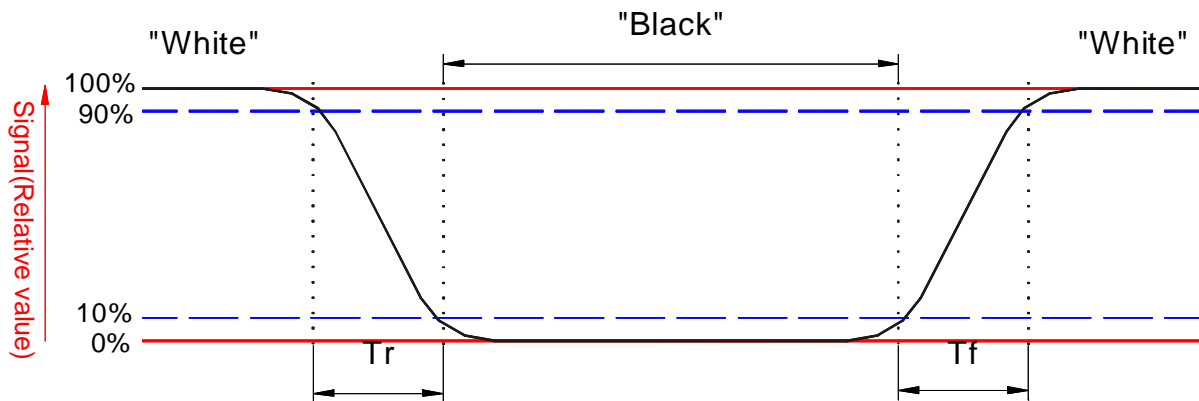

Note 4. Definition of contrast ratio:

Contrast ratio is calculated with the following formula.

$$\text{Contrast ratio (CR)} = \frac{\text{Photo detector output when LCD is at "White" state}}{\text{Photo detector output when LCD is at "Black" state}}$$

Note 5. White $V_i = V_{i50} + 1.5V$

Black $V_i = V_{i50} \pm 2.0V$

" \pm " means that the analog input signal swings in phase with V_{COM} signal.

" $\bar{\pm}$ " means that the analog input signal swings out of phase with V_{COM} signal.

V_{i50} : The analog input voltage when transmission is 50%

The 100% transmission is defined as the transmission of LCD panel when all the input terminals of module are electrically opened.

Note 6. Definition of viewing angle, details please refer to figure as below.

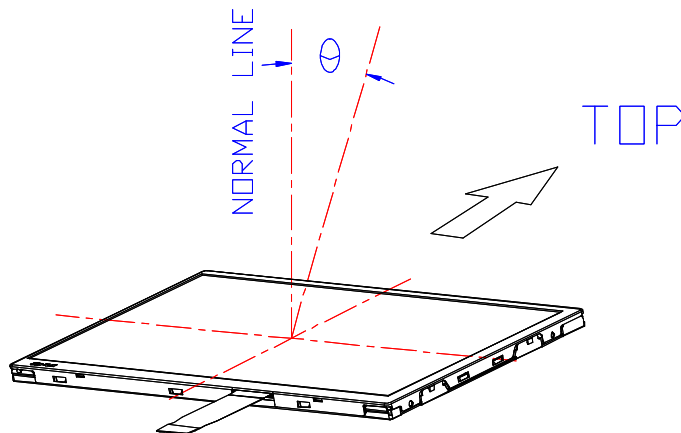

Note 7. Measured at the center area of the panel when all the input terminals of LCD panel are electrically opened.

D. Reliability test items (Note 1):

Following the below condition for test criteria. Each item needs 5 piece data.

No.	Test items	Conditions	Remark
1	High temperature storage	Ta= 85°C 240Hrs	
2	Low temperature storage	Ta= -30°C 240Hrs	
3	High temperature operation	Tp= 70°C 240Hrs	
4	Low temperature operation	Tp= -20°C 240Hrs	
5	High temperature and high humidity	Tp= 40°C, 90% RH 240Hrs	Operation
6	Heat shock	-10°C~60°C/200 cycles 1Hrs/cycle	Non-operation
7	Electrostatic discharge	±200V,200pF(0Ω), once for each terminal	Non-operation
8	Vibration	Frequency range : 10~55Hz Stoke : 1.5mm Sweep : 10 ~ 55 ~ 10Hz 2 hours for each direction of X,Y,Z (6 hours for total)	JIS C7021, A-10 Condition A
9	Mechanical shock	100G, 6ms, ±X,±Y,±Z 3 times for each direction	JIS C0041, A-7 Condition C
10	Vibration (with carton)	Random vibration: 0.015G ² /Hz from 5~200Hz	IEC 68-34
11	Drop (with carton)	Height: 60cm	JIS Z0202

Note1: Ta: Ambient temperature.

Note2: Tp: Panel Surface Temperature

Note3: In the standard conditions, there is not display function NG issue occurred. All the cosmetic specification is judged before the reliability stress.

E. Packing form

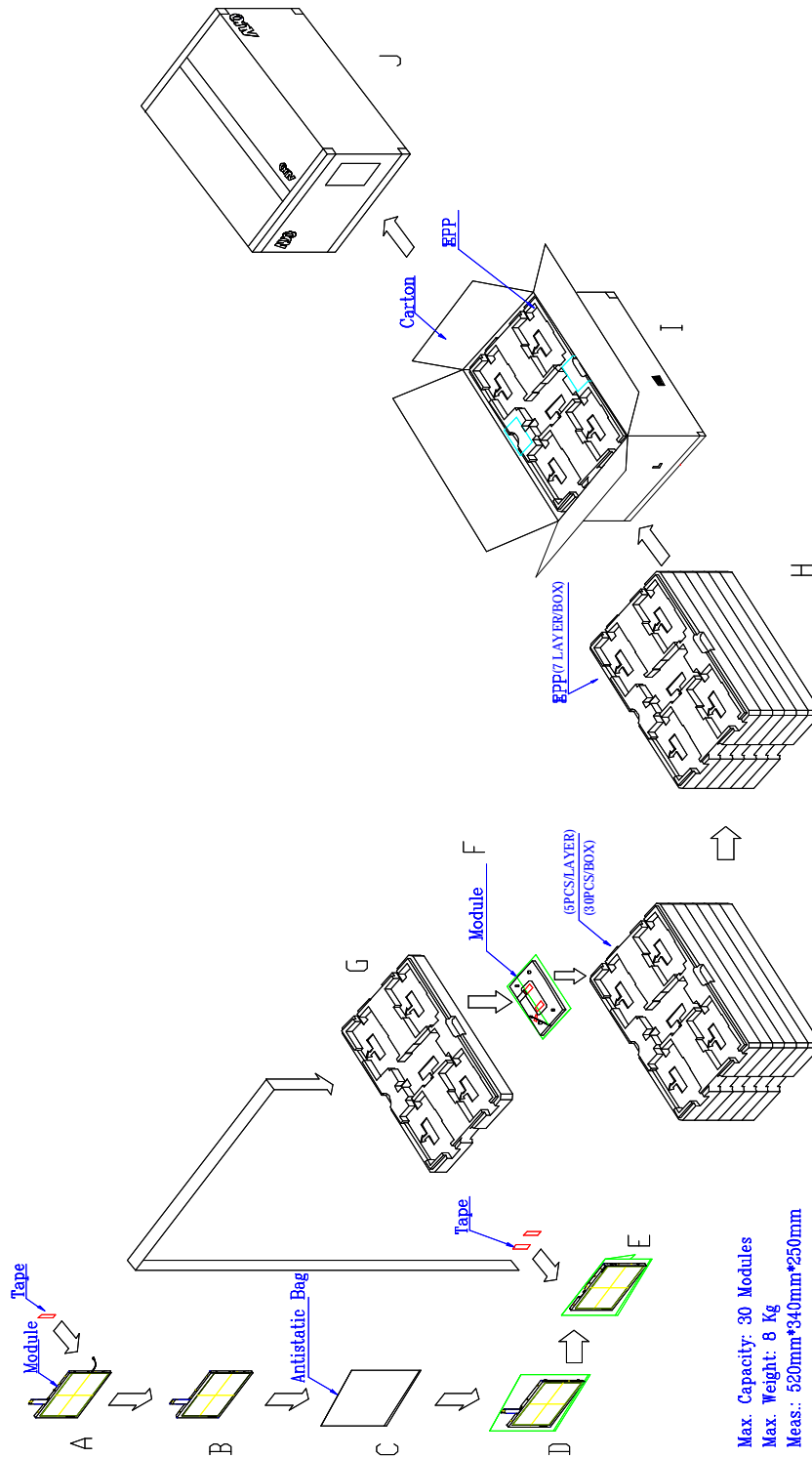

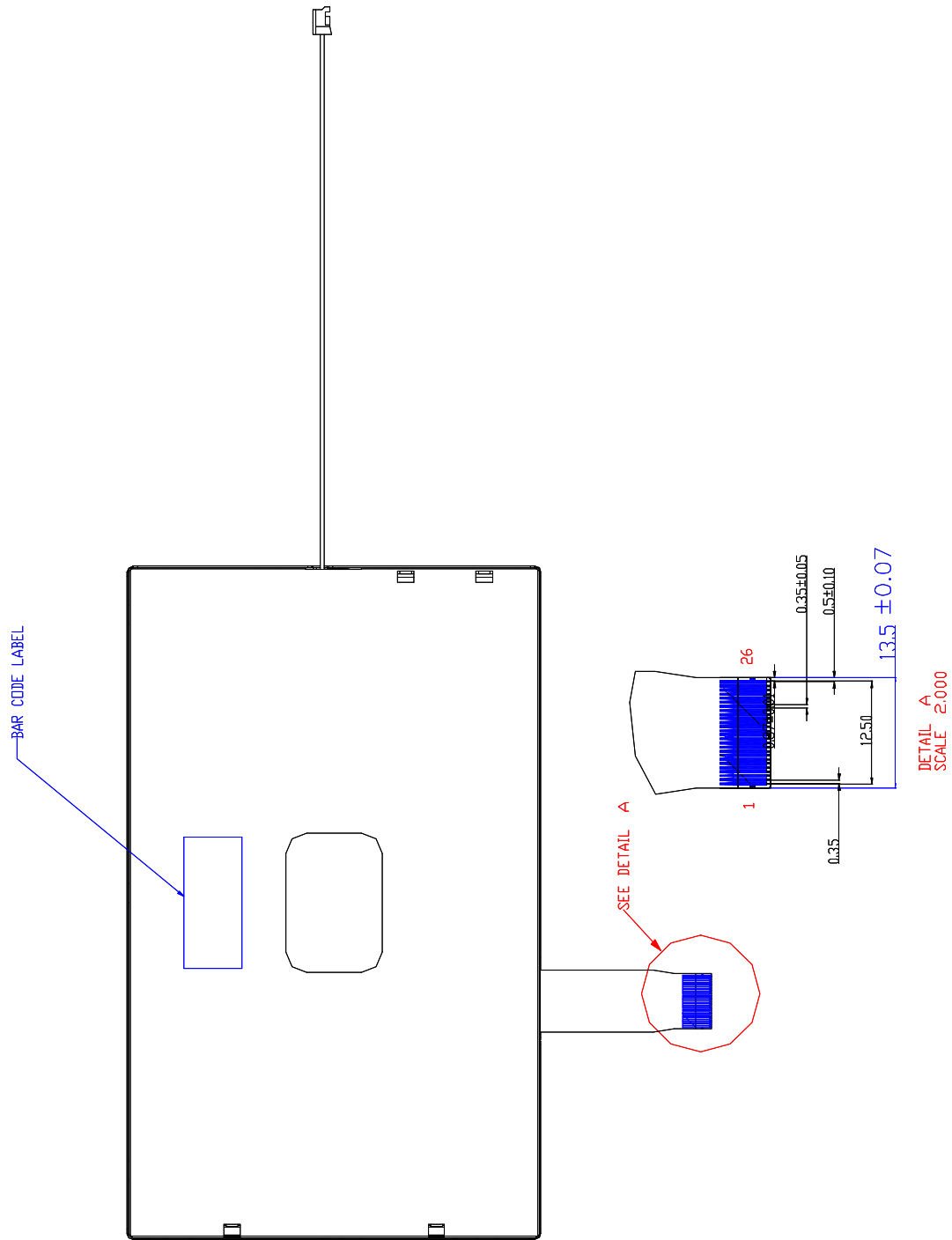

Fig.1-(b) Outline dimension of TFT-LCD module (Back)

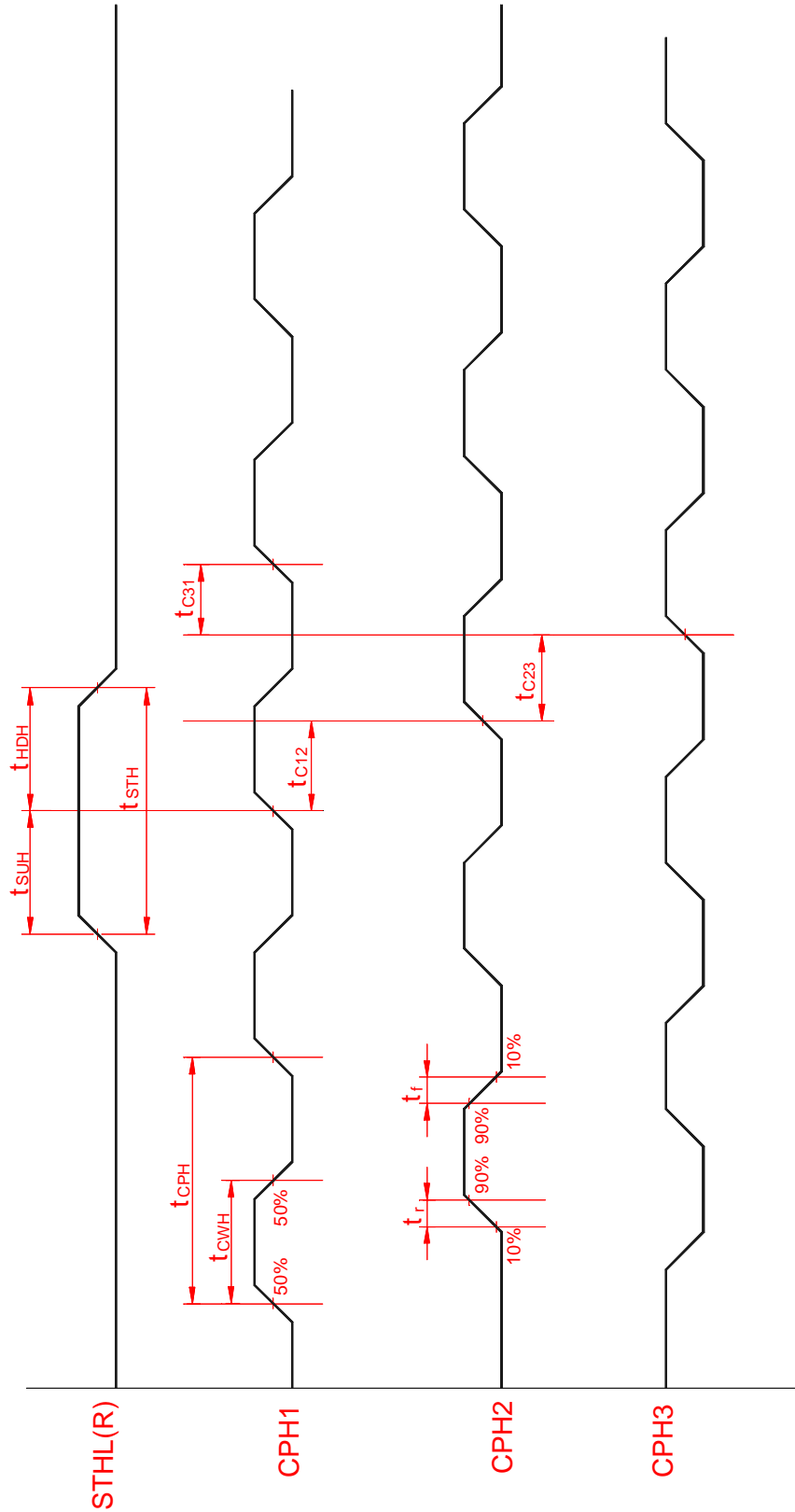

Fig.2 Sampling clock timing

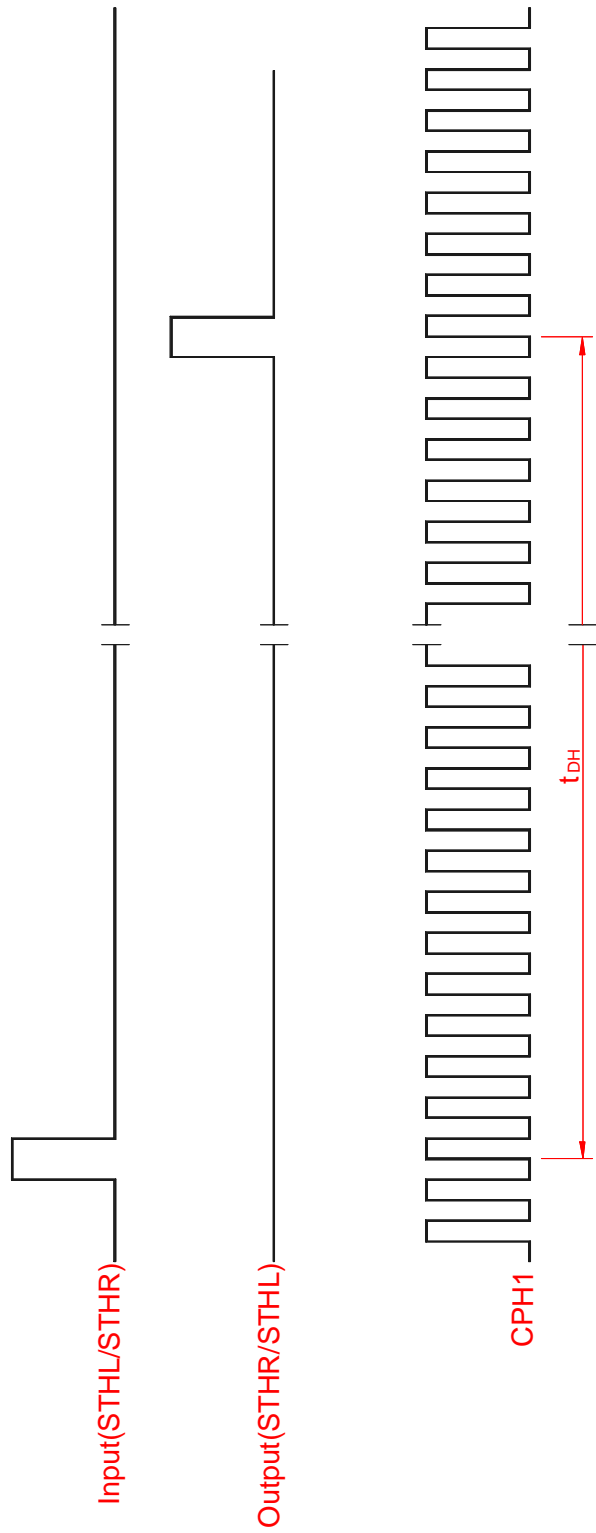

Fig.3 Horizontal display timing range

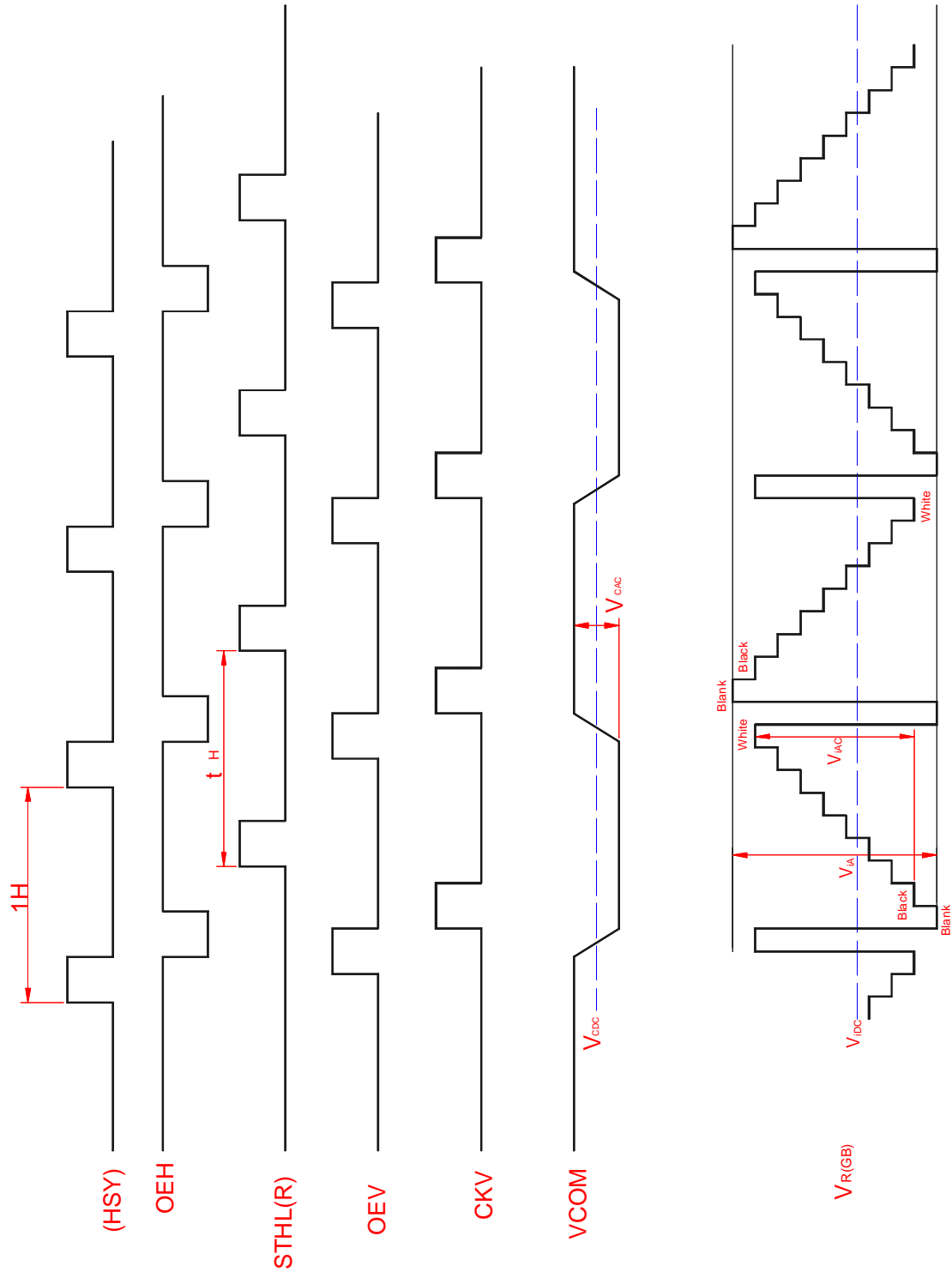
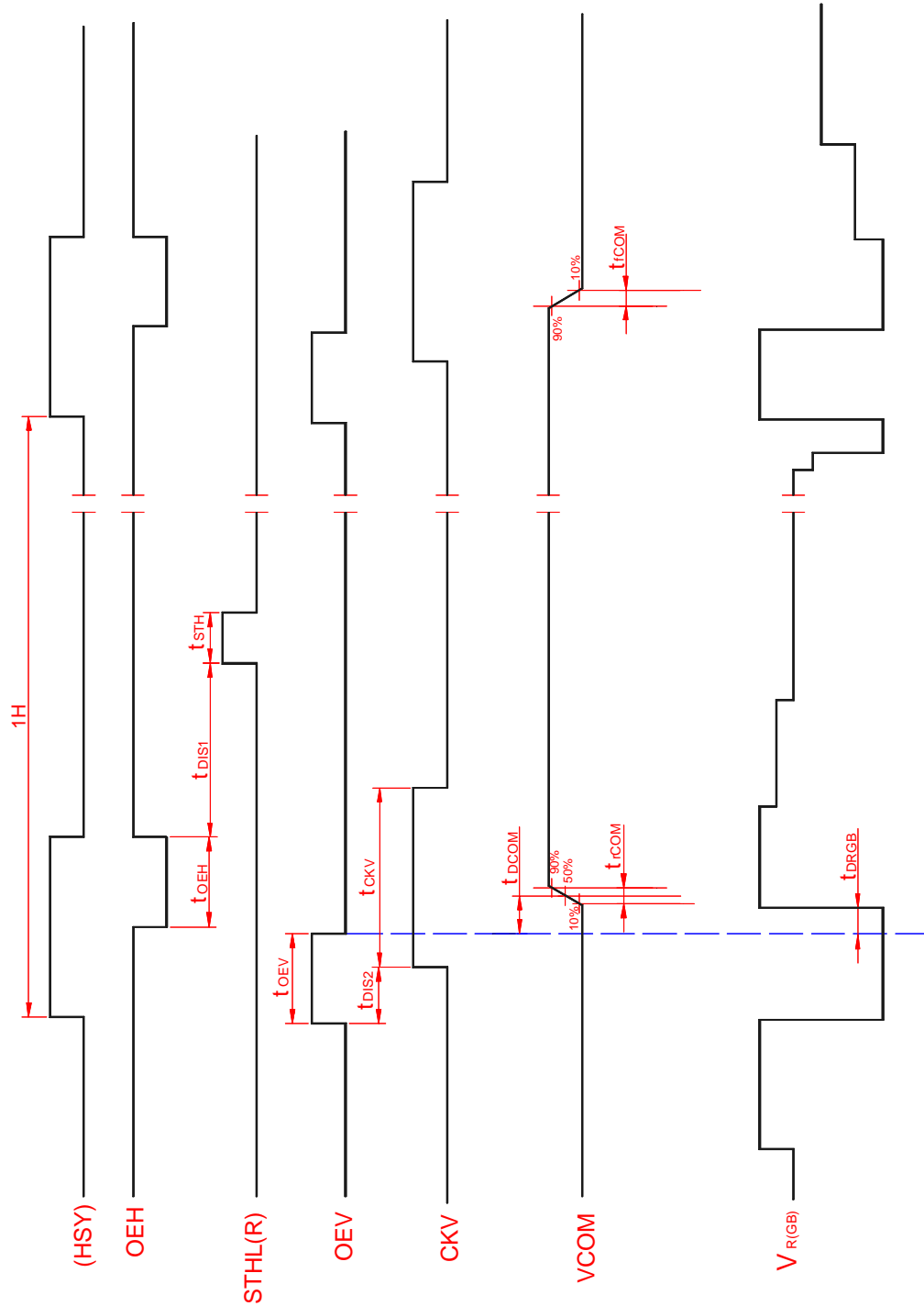

Fig.4-(a) Horizontal timing



Note: The falling edge of OEV should be synchronized with the falling edge of OEH

Fig.4-(b) Detail horizontal timing

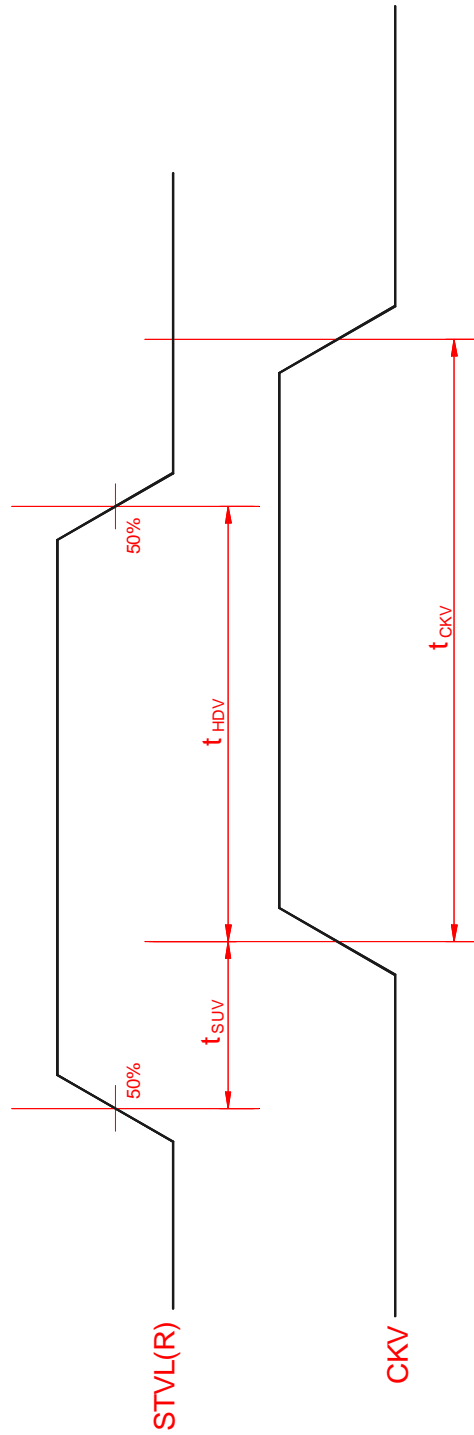

Fig.5 Vertical shift clock timing

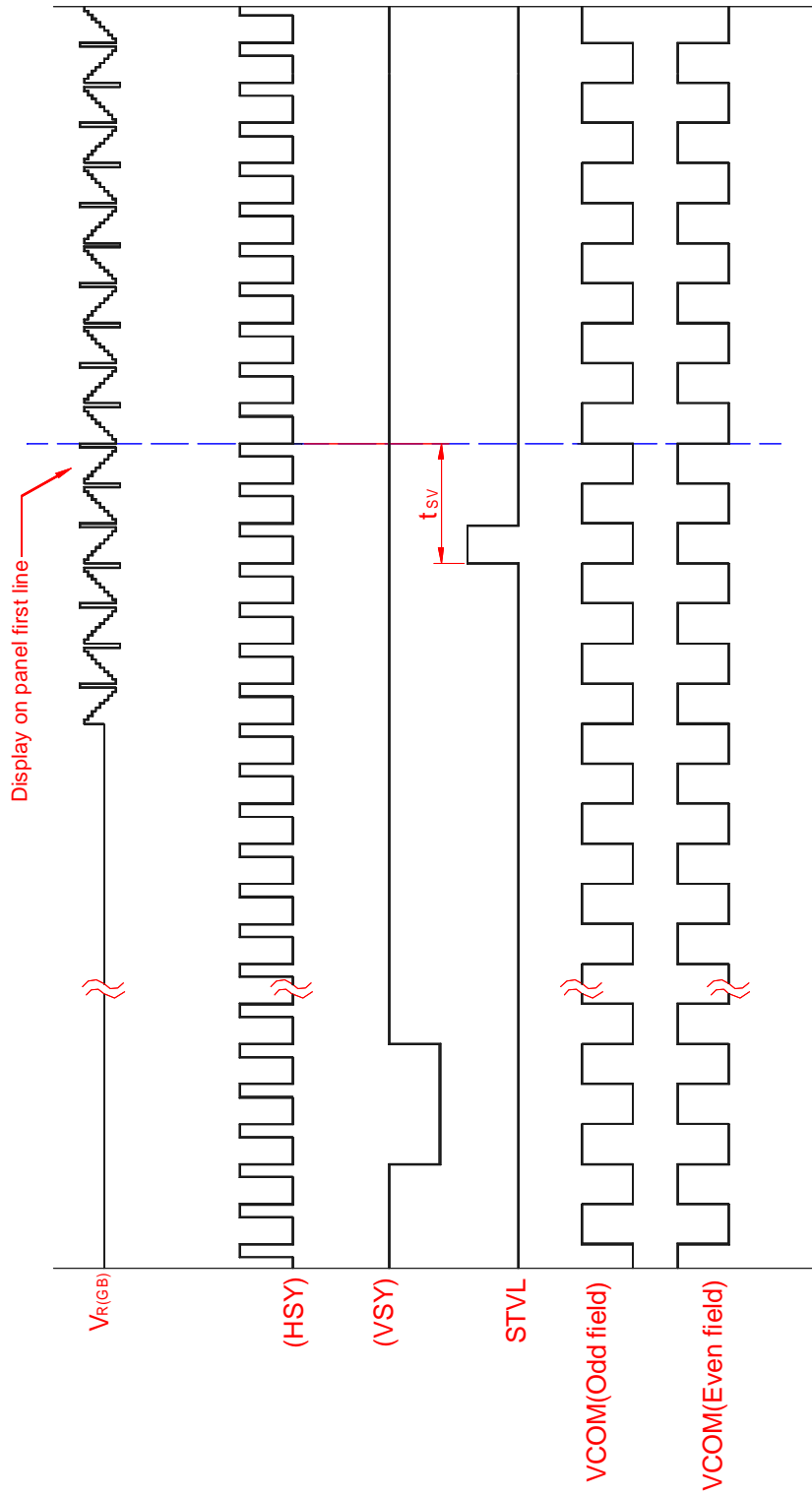

Fig.6-(a) Vertical timing (From up to down)

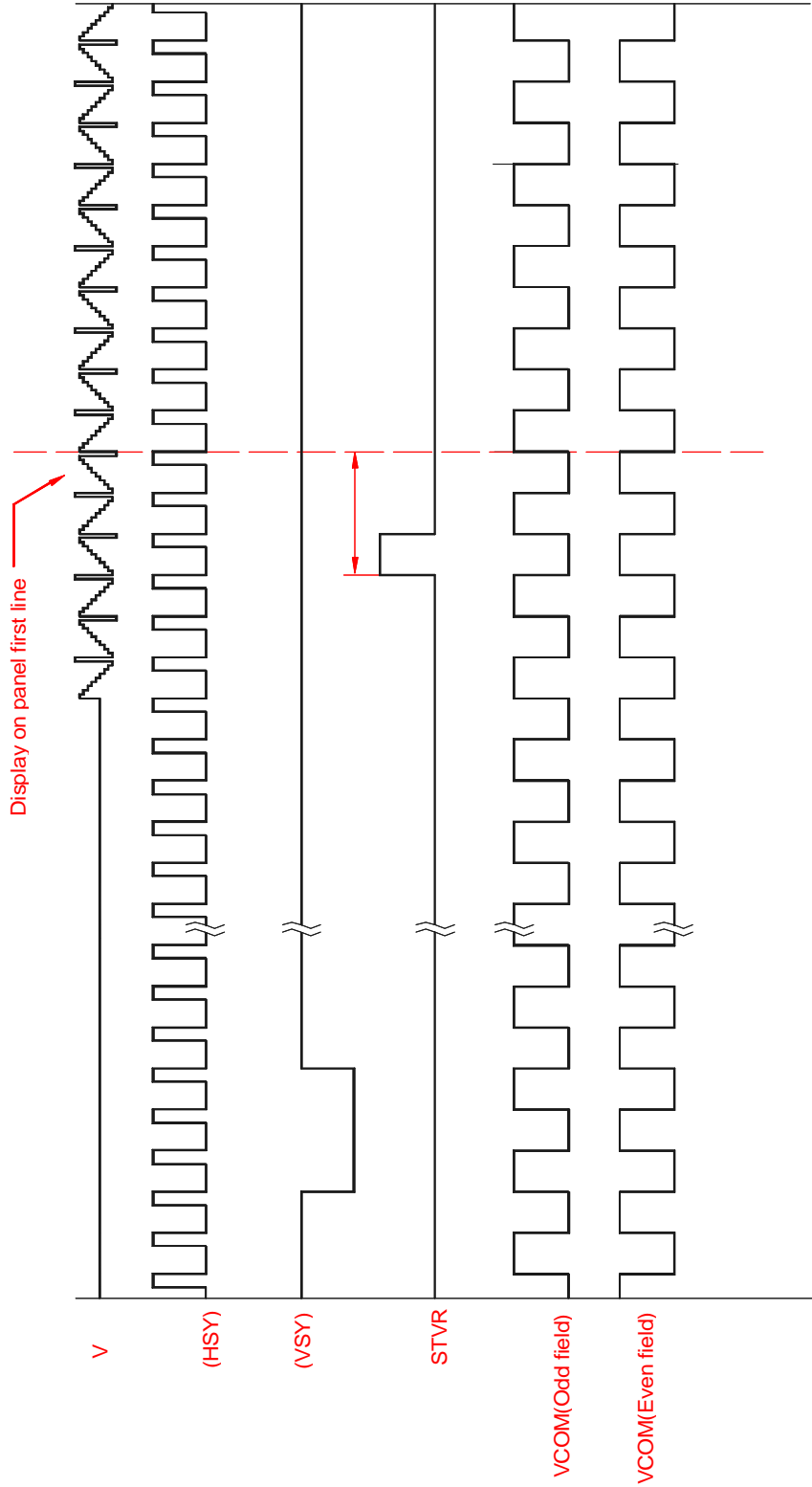

Fig.6-(b) Vertical timing (From down to up)