

# HITACHI

For Messrs : \_\_\_\_\_

Date : Sep. 6, '99

## CUSTOMER'S ACCEPTANCE SPECIFICATIONS

### SX25S004

### CONTENTS

No.	ITEM	Sheet No.	Page
1	COVER	3284PS 2701 - SX25S004 - 2	1-1/1
2	RECORD OF REVISION	3284PS 2702 - SX25S004 - 2	2-1/1
3	MECHANICAL DATA	3284PS 2703 - SX25S004 - 2	3-1/1
4	ABSOLUTE MAXIMUM RATINGS	3284PS 2704 - SX25S004 - 2	4-1/1
5	ELECTRICAL CHARACTERISTICS	3284PS 2705 - SX25S004 - 2	5-1/2~ 5-2/2
6	OPTICAL CHARACTERISTICS	3284PS 2706 - SX25S004 - 2	6-1/3~ 6-3/3
7	BLOCK DIAGRAM	3284PS 2707 - SX25S004 - 2	7-1/1
8	INTERFACE TIMING CHART	3284PS 2708 - SX25S004 - 2	8-1/7~ 8-7/7
9	DIMENSIONAL OUTLINE	3283PS 2709 - SX25S004 - 2	9-1/1
10	APPEARANCE STANDARD	3284PS 2710 - SX25S004 - 2	10-1/3~ 10-3/3
11	PRECAUTION IN DESIGN	3284PS 2711 - SX25S004 - 2	11-1/4~ 11-4/4
12	DESIGNATION OF LOT MARK	3284PS 2712 - SX25S004 - 2	12-1/2~ 12-2/2
13	PRECAUTION FOR USE	3284PS 2713 - SX25S004 - 2	13-1/1

Accepted by : \_\_\_\_\_

Proposed by : *N. Aoyan*

Displays, Hitachi, Ltd.	Sh. No.	3284PS 2701 - SX25S004 - 2	Page	1-1/1
-------------------------	------------	----------------------------	------	-------

## RECORD OF REVISION

Date	Sheet No.	Summary
Sep. 6, '99	3284PS 2711-SX25S004-2 Page 11-2/4	11.1 MOUNTING PRECAUTION Added (5)

### 3. MECHANICAL DATA

(1) Part Name	SX25S004
(2) Module Size	236.0(W) mm × 168.0(H) mm × 6.3 max (D) mm
(3) Display Size	Diagonal size 25cm (10.0")
(4) Dot Pitch	0.0845(W) mm × 0.2535(H) mm
(5) Number of Dots	800 × 3 (R,G,B)(W) × 600 (H) dots
(6) Duty	1/300
(7) LCD	Film type (negative type) The upper polarizer is an anti-glare type. (Hardness:3H)
(8) View ing Direction	12 O'clock
(9) Backlight	Cold Cathode Fluorescent Lamp (CFL) × 1
(10) Weight	(330) g
(11) Pow er Supply Voltage	3.3V only

#### 4. ABSOLUTE MAXIMUM RATINGS

##### 4. 1 ELECTRICAL ABSOLUTE MAXIMUM RATINGS

VSS=0V:Standard

ITEM	SYMBOL	MIN	MAX	UNIT	COMMENT
Power Supply for Logic	VDD-VSS	0	4.6	V	
Contrast Adjustment Voltage	VCON-VSS	0	VDD	V	
Input Voltage	$V_i$	-0.3	VDD+0.3	V	Note 1
Input Current	$I_i$	0	1	A	
Static Electricity	-	-	-	-	Note 2

Note 1  $\overline{\text{DISP OFF}}$ , FLM, CL1, CL2, UD0~UD7, LD0~LD7

Note 2 Make certain you are grounded when handling LCM

##### 4. 2 ENVIRONMENTAL ABSOLUTE MAXIMUM RATINGS

ITEM	OPERATING		STORAGE		COMMENT
	MIN	MAX	MIN	MAX	
Ambient Temperature	5°C	40°C	-20°C	60°C	Note 2, 3
Humidity	Note 1		Note 1		Without condensation
Vibration	-	2.45 m/s <sup>2</sup> (0.25G)	-	11.76 m/s <sup>2</sup> (1.2G) Note 5	Note 4
Shock	-	29.4 m/s <sup>2</sup> (3G)	-	490 m/s <sup>2</sup> (50G) Note 5	XYZ directions 11ms
Corrosive Gas	Not Acceptable		Not Acceptable		

Note 1  $T_a \leq 40^\circ\text{C}$  : 85%RH max.

$T_a > 40^\circ\text{C}$  : Absolute humidity must be lower than the humidity of 85%RH at 40°C.

Note 2  $T_a$  at -20°C ----- <48h, at 60°C ----- <168h

Note 3 Background color changes slightly depending on ambient temperature.  
This phenomenon is reversible.

Note 4 5Hz~100Hz (Except resonance frequency)

Note 5 This module should be operated normally after finish the test.

Note 6 When LCM is operated at 5°C, the life time of CFL will be reduced.  
Need to make sure of value of IL and characteristics of inverter.  
Also the response time at 5°C will be slower.

## 5. ELECTRICAL CHARACTERISTICS

### 5. 1 ELECTRICAL CHARACTERISTICS OF LCD

VSS=0V

ITEM	SYMBOL	CONDITION	MIN	TYP	MAX	UNIT
Power Supply Voltage	VDD	VDD-VSS=3.3V	3.15	3.30	3.45	V
Contrast Adjustment Voltage (Note 1)	VCON	-	1.2	-	2.4	V
Input Voltage for Logic Circuits (Note 2)	Vi	"H" level	0.8VDD	-	VDD	V
		"L" level	0	-	0.2VDD	
Power Supply Current (Note 3)(Note 6)	IDD	VDD-VSS=3.3V	-	120	200	mA
Input Leak Current	I <sub>con</sub> (Note4)	V <sub>con</sub> =0.8~2.8V	-	-	(20)	μA
	I <sub>in</sub> (Note2)	V <sub>in</sub> =VDDorVSS	-	-	±1.0	
Contrast Adjustment Voltage (Note 7)	V <sub>con</sub>	T <sub>a</sub> = 5°C, φ=0°	1.2	-	-	V
		T <sub>a</sub> =25°C, φ=0°	1.5	1.9	2.3	
		T <sub>a</sub> =40°C, φ=0°	-	-	2.4	
Frame Frequency (Note 5)	fFLM	-	70	120	130	Hz

(Note 1) In proportion as the VCON voltage decrease the brightness will increase.

(Note 2) DISP OFF, FLM, CL1, CL2, UD0~UD7, LD0~LD7

(Note 3) fFLM=120Hz, T<sub>a</sub>=25°C, Display pattern:Checker pattern.

(Note 4) VCON

(Note 5) Need to make sure of flickering and rippling of display when setting the Frame Frequency in your set.

(Note 6) Rush Current of Power ON : 0.8A × 10ms

(Note 7) The Contrast Adjustment Voltage is specified as 1.9±0.4V under the condition, when an optimum contrast is obtained by naked eyes as the "Q" test pattern.

fFLM=120Hz, 1/313Duty

## 5. 2 ELECTRICAL CHARACTERISTICS OF BACKLIGHT

ITEM	SYMBOL	MIN	TYP	MAX	UNIT	NOTE
Lamp Voltage	VL	-	(500)	-	Vrms	Ta=25°C
Frequency	fL	50	60	-	kHz	
Lamp Current (1Lamp)	IL	3.5 (Note 5)	5	5.5 (Note 5)	mA	Ta=25°C
Starting discharge Voltage	VS (Note 2)	(1500)	-	-	Vrms	Ta=5°C

- (Note 1) Please design your lamp driving circuit (inverter) according to the above specifications, and inform Hitachi of it.
- (Note 2) Starting discharge voltage is increased when LCM is operating at lower temperature. Please check the characteristics of your inverter before applying to your set.
- (Note 3) Average life time of CFL will be decreased when LCM is operating at lower temperature.
- (Note 4) Under lower driving frequency of an inverter, a certain backlight system (CFL & CFL reflection sheet) may generate a sound noise. Before designing the inverter, please consider the driving frequency and the noise.
- (Note 5) When ICFL is used over 5.5mA, it may cause uneven contrast near CFL location, due to heat dispersion from CFL.

6. OPTICAL CHARACTERISTICS

6.1 OPTICAL CHARACTERISTICS OF LCD

Ta=25°C (Backlight On)

ITEM		SYMBOL	CONDITION	MIN	TYP	MAX	UNIT	NOTE
Viewing area		$\phi 2-\phi 1$	$\theta=0^\circ, K \geq 2.0$	-	(40)	-	deg	1),2)
Contrast ratio		K	$\phi=0^\circ, \theta=0^\circ$	25	50	-	-	3),5),6)
Response time (rise)		tr	$\phi=0^\circ, \theta=0^\circ$	-	170	225	ms	4)
Response time (fall)		tf	$\phi=0^\circ, \theta=0^\circ$	-	130	225	ms	4)
Color tone (Primary Color)	Red	x	$\phi=0^\circ, \theta=0^\circ$	0.48	0.53	0.58	-	7)
		y		0.25	0.30	0.35	-	
	Green	x		0.26	0.31	0.36	-	
		y		0.46	0.51	0.56	-	
	Blue	x		0.11	0.16	0.21	-	
		y		0.09	0.14	0.19	-	
	White	x		0.26	0.31	0.36	-	
		y		0.27	0.32	0.37	-	

(Measurement condition : Hitachi standard)

Note 1)~7) : See next page.

Note 1. Definition of  $\theta$  and  $\phi$

(Normal)

Viewing direction

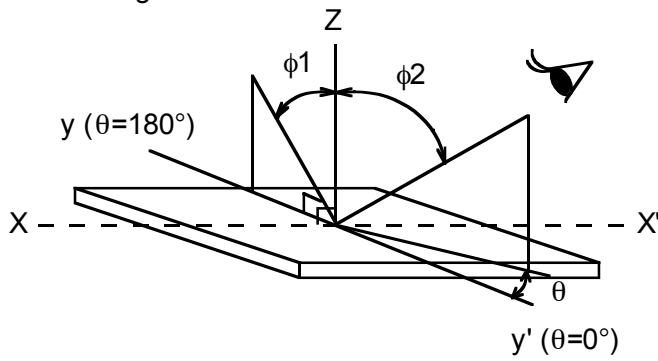

Note 3. Definition of contrast "K"

$$K = \frac{\text{Brightness on selected area (B1)}}{\text{Brightness on non-selected area (B2)}}$$

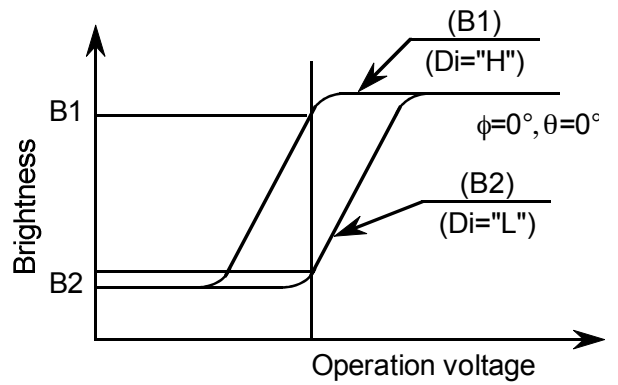

Note 2. Definition of view ing angle  $\phi_1$  and  $\phi_2$

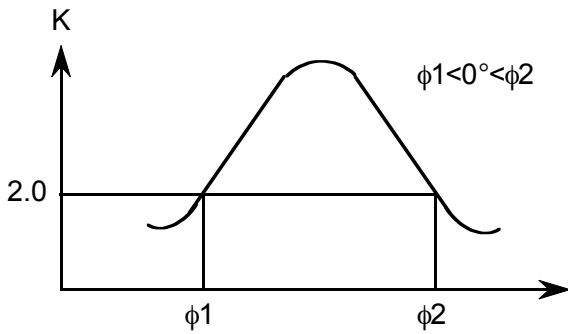

Contrast ratio K vs view ing angle  $\phi$

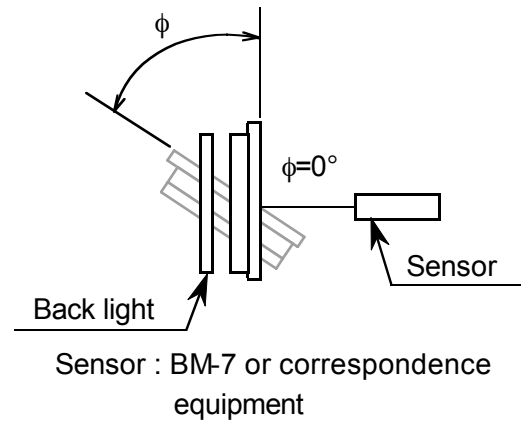

Sensor : BM-7 or correspondence equipment

Note 4. Definition of optical response time

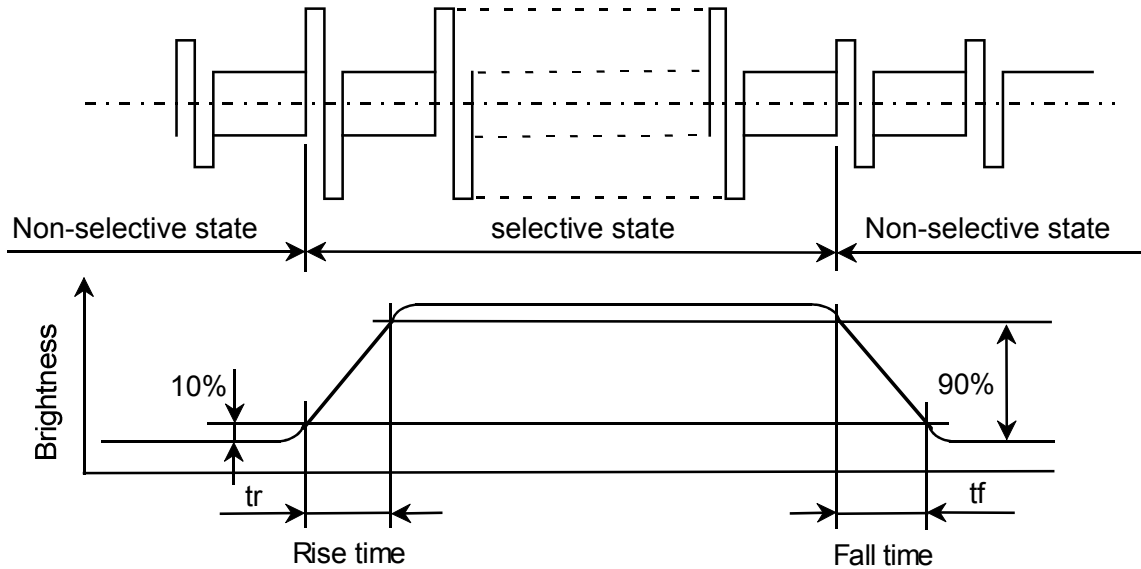

Note 5. Hitachi will not do 100% inspection for minimum value. Minimum value is for reference.

Note 6. Hitachi will do sampling inspection for minimum value.

Note. 7 The LCD driving voltage should be adjusted at the voltage where the peak contrast is obtained.



## 6.2 OPTICAL CHARACTERISTICS OF BACKLIGHT

ITEM	MIN	TYP	MAX	UNIT	NOTE
Brightness	70	100	-	cd/m <sup>2</sup>	IL=5.0mA Note 1),2)
Rise Time	-	5	-	Minute	IL=5.0mA Brightness 80%
Brightness Uniformity	-	-	±30	%	Undermentioned Note 1),4)

(Measurement condition : Hitachi standard)

CFL : INITIAL, Ta=25°C

Display data should be all "ON"

The LCD driving voltage should be adjusted at the voltage where the peak contrast is obtained, when set pattern is all "Q".

(Note 1) Measurement after 10 minutes from CFL operating.

Average value of 5 points (Note 3).

(Note 2) Brightness control : 100%

(Note 3) Measurement of the following 5 places on the display.

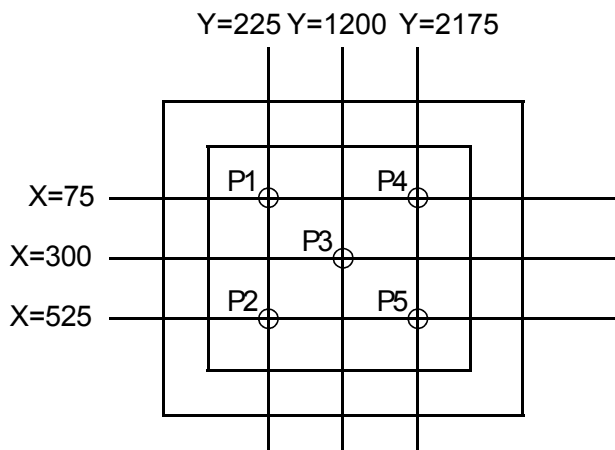

(Note 4) Definition of the brightness tolerance.

$$\left( \frac{\text{Max brightness or Min brightness} - \text{Average brightness}}{\text{Average brightness}} \right) \times 100$$

# 7. BLOCK DIAGRAM

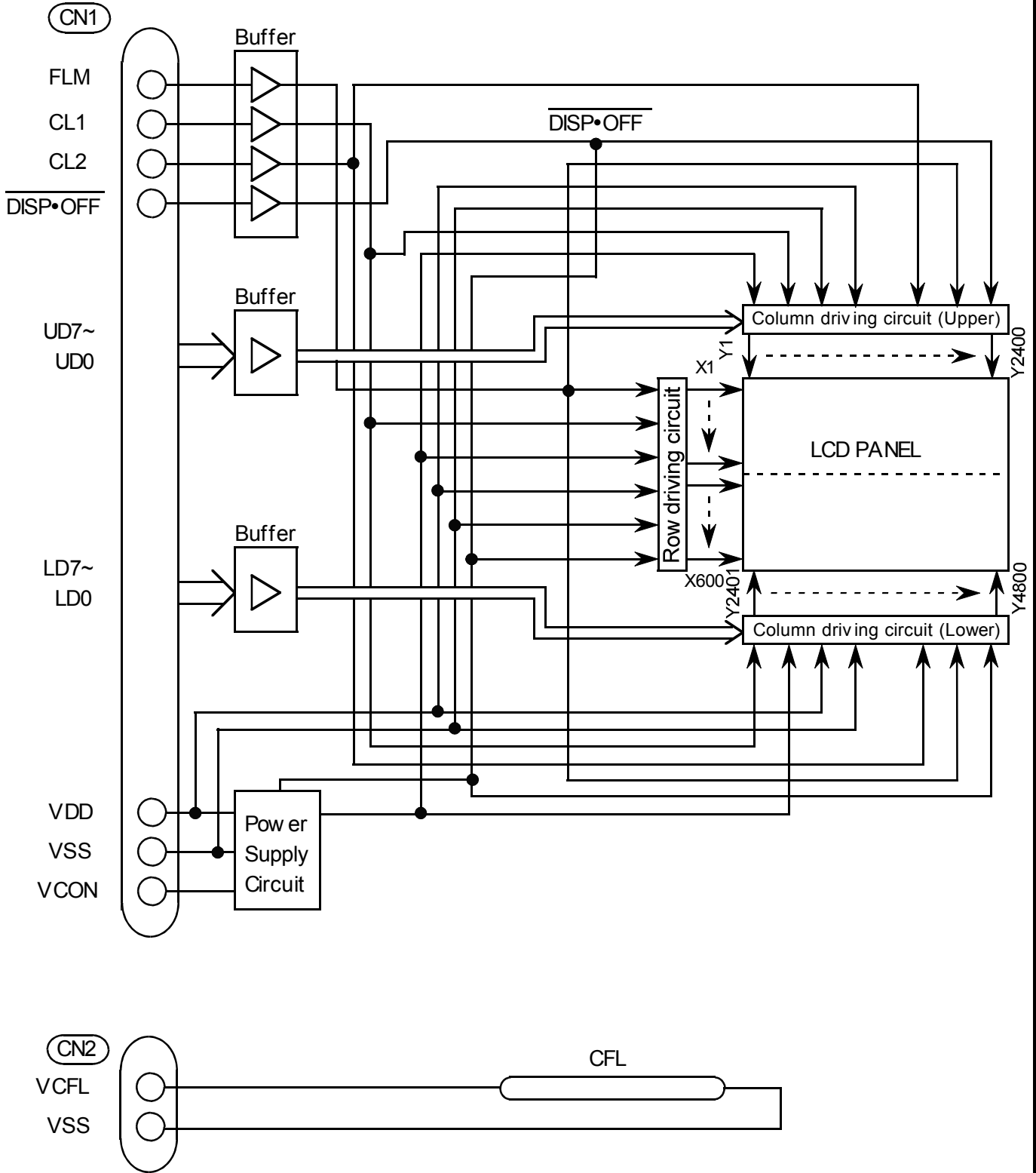

# 8. INTERFACE TIMING CHART

## 8.1 TIMING CHART

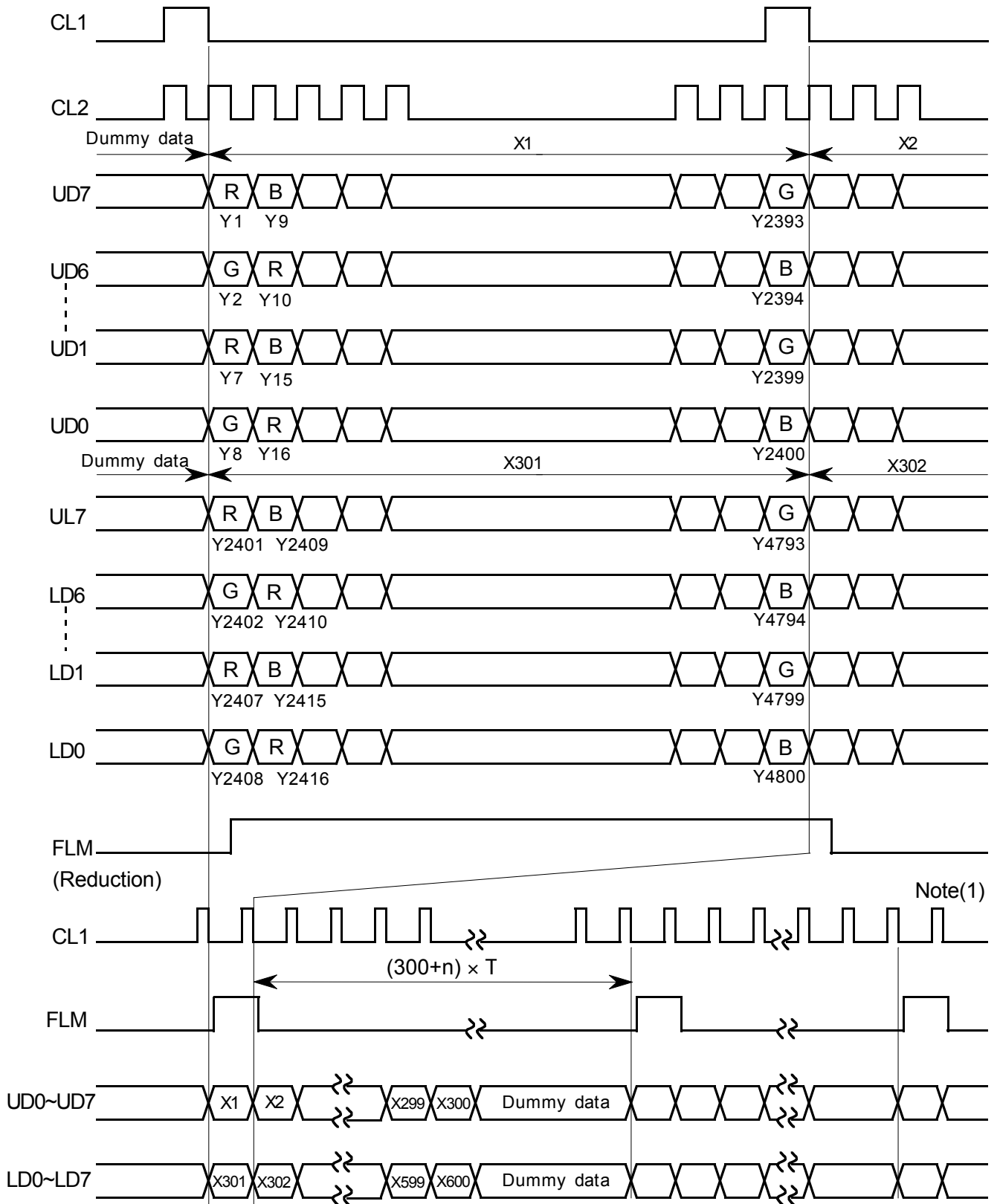

Note(1) : The interval of CL1 pulse must be same including the vertical blanking period.

## 8.2 INTERFACE TIMING SPECIFICATION

VDD=3.3±0.15V, VSS=0V, Vcon=1.2~2.4V, Ta=+5°C~+40°C

ITEM	SYMBOL	MIN	TYP	MAX	UNIT
CL1 pulse width "H"	t <sub>WHCL1</sub>	150	—	—	ns
Clock cycle time	t <sub>CYC</sub>	50	—	—	ns
CL2 pulse width	t <sub>WCL2</sub>	15	—	—	ns
Clock set up time	t <sub>SCL1</sub>	110	—	—	ns
Clock hold time	t <sub>HCL1</sub>	110	—	—	ns
Clock rise fall time	t <sub>r</sub> , t <sub>f</sub>	—	—	50	ns
Data set up time	t <sub>DSU</sub>	10	—	—	ns
Data hold time	t <sub>DH</sub>	10	—	—	ns
"FLM" set up time	t <sub>FS</sub>	120	—	—	ns
"FLM" hold time	t <sub>FH</sub>	300	—	—	ns
Set up time	t <sub>FSD</sub>	120	—	—	ns
Hold time	t <sub>FHD</sub>	120	—	—	ns

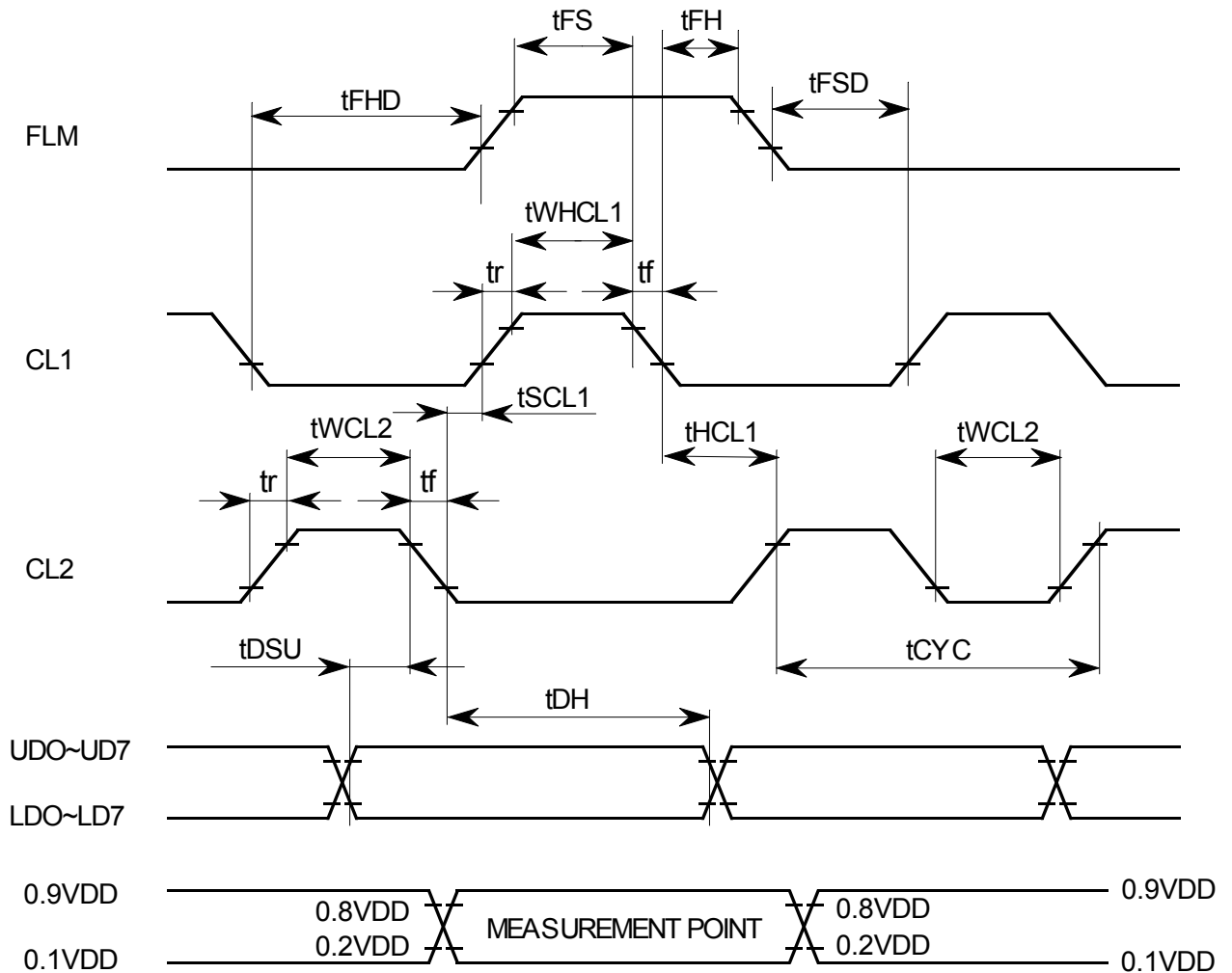

### 8.3 POWER ON / OFF SEQUENCE

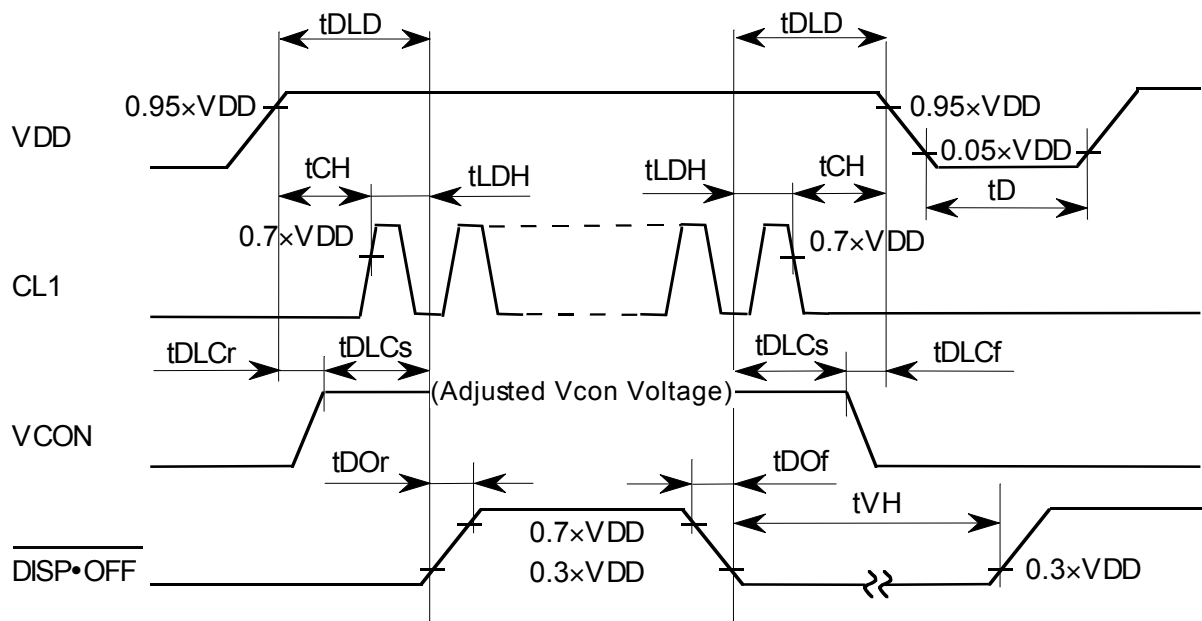

SYMBOL	MIN	MAX	UNIT	COMMENT
tDLD	100		ms	(Note 1)
tCH	0	200	ms	
tLDH	20		ms	
tDOr		100	ns	(Note 2)
tDOF		100	ns	
tDLCr	0		ms	
tDLCf	0		ms	(Note 2, 3)
tDLCs	0		ms	
tVH	200		ms	(Note 4)

(Note 1) Please keep the specified sequence because wrong sequence may cause permanent damage to the LCD panel.

(Note 2) Hitachi recommends you to use DISP•OFF function.  
Display quality may deteriorate if you don't use DISP•OFF function.

(Note 3)  $1.2 \leq V_{con} \leq 2.4V$   
Vcon voltage should be set up to adjusted voltage before DISP•OFF signal arises.  
Otherwise, when DISP•OFF signal arises, adjusted contrast image may not be generated.

(Note 4) Please keep the specified sequence of DISP•OFF signal because if the tVH is short enough, LCD panel may not be restarted.

### 8.4 POWER SUPPLY FOR LCM

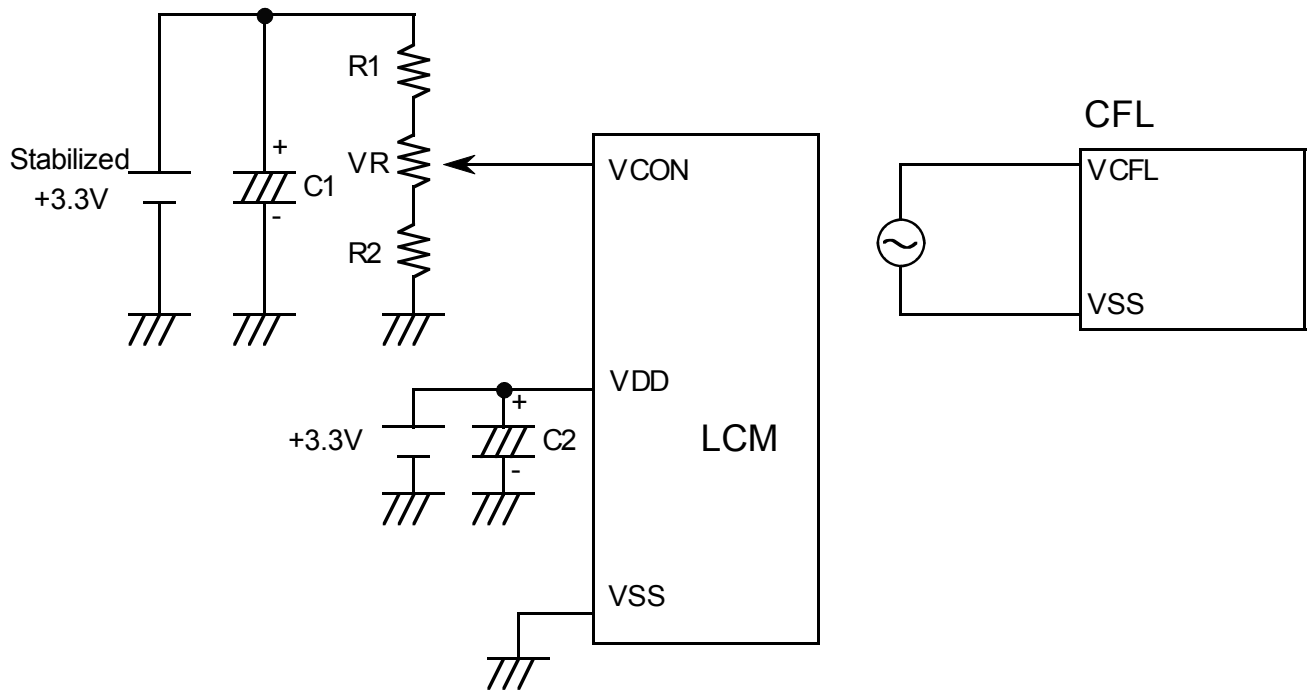

$$R1 + VR + R2 \leq 10k\Omega$$

8.5 INPUT DATA ALLOCATION TABLE

Data Signal	U D 7	U D 6	U D 5	U D 4	U D 3	U D 2	U D 1	U D 0	U D 7	U D 6	U D 5	U D 4	-----	U D 4	U D 3	U D 2	U D 1	U D 0	
Y	1	2	3	4	5	6	7	8	9	10	11	12	-----	2	2	2	2	2	
X														3	3	3	3	4	
														9	9	9	9	0	
														6	7	8	9	0	
UPPER PANEL	1	R	G	B	R	G	B	R	G	B	R	G	B	-----	G	B	R	G	B
	2	R	G	B	R	G	B	R	G	B	R	G	B	-----	G	B	R	G	B
	3	R	G	B	R	G	B	R	G	B	R	G	B	-----	G	B	R	G	B
	4	R	G	B	R	G	B	R	G	B	R	G	B	-----	G	B	R	G	B
	5	R	G	B	R	G	B	R	G	B	R	G	B	-----	G	B	R	G	B
	⋮	⋮	⋮	⋮	⋮	⋮	⋮	⋮	⋮	⋮	⋮	⋮	⋮		⋮	⋮	⋮	⋮	⋮
	298	R	G	B	R	G	B	R	G	B	R	G	B	-----	G	B	R	G	B
	299	R	G	B	R	G	B	R	G	B	R	G	B	-----	G	B	R	G	B
	300	R	G	B	R	G	B	R	G	B	R	G	B	-----	G	B	R	G	B
	301	R	G	B	R	G	B	R	G	B	R	G	B	-----	G	B	R	G	B
302	R	G	B	R	G	B	R	G	B	R	G	B	-----	G	B	R	G	B	
303	R	G	B	R	G	B	R	G	B	R	G	B	-----	G	B	R	G	B	
304	R	G	B	R	G	B	R	G	B	R	G	B	-----	G	B	R	G	B	
305	R	G	B	R	G	B	R	G	B	R	G	B	-----	G	B	R	G	B	
⋮	⋮	⋮	⋮	⋮	⋮	⋮	⋮	⋮	⋮	⋮	⋮	⋮		⋮	⋮	⋮	⋮	⋮	
598	R	G	B	R	G	B	R	G	B	R	G	B	-----	G	B	R	G	B	
599	R	G	B	R	G	B	R	G	B	R	G	B	-----	G	B	R	G	B	
600	R	G	B	R	G	B	R	G	B	R	G	B	-----	G	B	R	G	B	
X	2	2	2	2	2	2	2	2	2	2	2	2		4	4	4	4	4	
	4	4	4	4	4	4	4	4	4	4	4	4		7	7	7	7	8	
	0	0	0	0	0	0	0	0	0	0	1	1	1	-----	9	9	9	9	0
Y	1	2	3	4	5	6	7	8	9	0	1	2		6	7	8	9	0	
Data Signal	L D 7	L D 6	L D 5	L D 4	L D 3	L D 2	L D 1	L D 0	L D 7	L D 6	L D 5	L D 4	-----	L D 4	L D 3	L D 2	L D 1	L D 0	

R : RED  
G : GREEN  
B : BLUE

## 8.6 INTERNAL PIN CONNECTION

CN1 Molex : SD-52974-040\* (Suitable Connector : Molex SD-53729-040\*)

PIN No.	SIGNAL	LEVEL	FUNCTION
1	GND	-	GND
2	CL2	H → L	Data Shift
3	GND	-	GND
4	GND	-	GND
5	CL1	H → L	Data Latch
6	FLM	H	First Line Marker
7	GND	-	GND
8	GND	-	GND
9	VDD	-	Power Supply for LCD
10	$\overline{\text{DISP}} \cdot \text{OFF}$	H / L	H : ON / L : OFF
11	GND	-	GND
12	GND	-	GND
13	GND	-	GND
14	LD7	H / L	Display Data (Lower Column)
15	LD6		
16	LD5		
17	LD4		
18	LD3		
19	LD2		
20	LD1		
21	LD0		
22	GND	-	GND
23	GND	-	GND
24	GND	-	GND
25	UD0	H / L	Display Data (Upper Column)
26	UD1		
27	UD2		
28	UD3		
29	UD4		
30	UD5		
31	UD6		
32	UD7		
33	GND	-	GND
34	GND	-	GND
35	GND	-	GND
36	VDD	-	Power Supply for LCD
37	VDD	-	Power Supply for LCD
38	VCON	-	Contrast Adjust
39	N.C	-	
40	GND	-	GND



CN2 JST : BHSR-02VS-1 (Suitable Connector : JST SM02B-BHSS-1)

PIN No.	SIGNAL	LEVEL	FUNCTION
1	VCFL	A C	Power Supply for CFL
2	VSS	-	GND for CFL

## 10. APPEARANCE STANDARD

### 10.1 APPEARANCE INSPECTION CONDITION

Visual inspection should be done under the following condition.

- (1) The inspection should be done in a dark room.
- (2) The CFL should be lighted with the prescribed inverter.
- (3) The distance between eyes of an inspector and the LCD Module is 25cm.
- (4) The viewing zone is shown in the figure.

Viewing angle  $\leq 25^\circ$

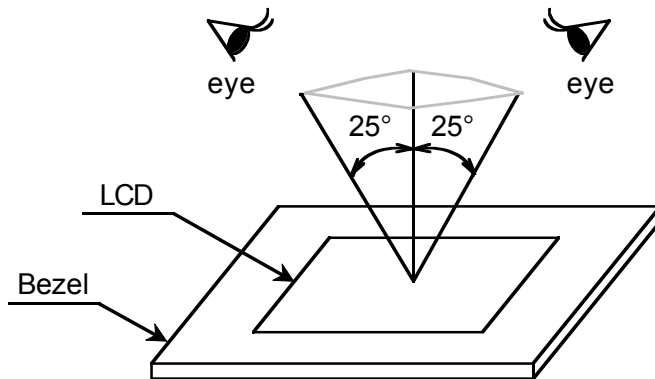

### 10.2 DEFINITION OF ZONE

A zone : The dots area specified at page 9-1/1 of this document.

B zone : The effective display area specified at page 9-1/1 of this document.

C zone : Area between the window of bezel line and the effective display area (B zone) line specified at page 9-1/1 of this document.

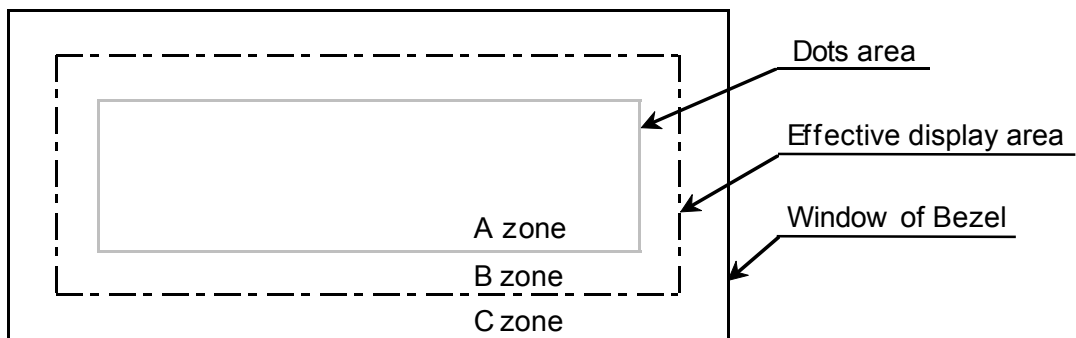

10.3 APPEARANCE SPECIFICATION

(1) LCD APPEARANCE

Note (1) If the problem related to this section occurs about this item, the responsible persons of both party (Customer and HITACHI) will discuss the matter detail.

No.	ITEM	CRITERIA			APPLIED ZONE	
L	Scratches	Note (1)			A	
	Dent	Same as above			A	
	Wrinkles in Polarizer	Same as above			A	
	Bubbles	Average diameter D (mm)		Maximum acceptable number		A
		D ≤ 0.2		ignored		
		0.2 < D ≤ 0.3		12		
		0.3 < D ≤ 0.5		3		
	0.5 < D		none			
	C	Stains, Foreign materials Dark spot	Filamentous (Line shape)			A,B
			Length L (mm)	Width W (mm)	Maximum acceptable number	
L ≤ 2.0			W ≤ 0.03	ignored		
L ≤ 3.0			0.03 < W ≤ 0.05	6		
L ≤ 2.5			0.05 < W ≤ 0.1	1		
D		Round (Dot shape)			A,B	
		Average diameter D (mm)	Maximum acceptable number	Minimum space		
		D < 0.2	ignored	—		
		0.2 ≤ D < 0.3	10	10 mm		
		0.3 ≤ D < 0.4	5	30 mm		
		0.4 ≤ D	none	—		
		The total number	Filamentous + Round = 10			
		Those w iped out easily are acceptable				
Color tone	Note (1)			A		
Color uniformity	Same as above			A		

No.	ITEM	CRITERIA			APPLIED ZONE	
L	Contrast irregularity (Spot)	Average diameter D (mm)	Contrast	Maximum acceptable number	Minimum space	A
		$D \leq 0.25$	To be judged by HITACHI STANDARD	ignored	—	
		$0.25 < D \leq 0.35$		10	20mm	
		$0.35 < D \leq 0.5$		4	20mm	
		$0.5 < D \leq 0.7$		3	50mm	
C		$0.7 < D$	none	—		
D	Contrast irregularity (Line) (A pair of scratches)	Width W (mm)	Length L (mm)	Maximum acceptable number	Minimum space	A
		$W \leq 0.25$	$L \leq 1.2$	2	20mm	
		$W \leq 0.2$	$L \leq 1.5$	3	20mm	
		$W \leq 0.15$	$L \leq 2.0$	3	20mm	
		$W \leq 0.1$	$L \leq 3.0$	4	20mm	
		The w hole number	6			
	Rubbing Scratch	Note (1)			—	

Note (2) Definition of Average diameter (D)

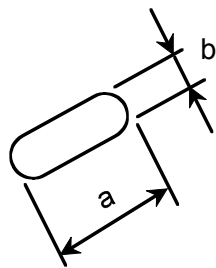

$$D = \frac{a+b}{2}$$

Note (3) Definition of Length (L) and Width (W)

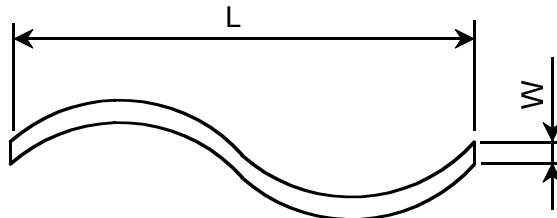

## 11. PRECAUTION IN DESIGN

### 11.1 MOUNTING PRECAUTION

Please mount the LCD Module using mounting holes arranged in 4 corners, and please pay attention to the follow ings.

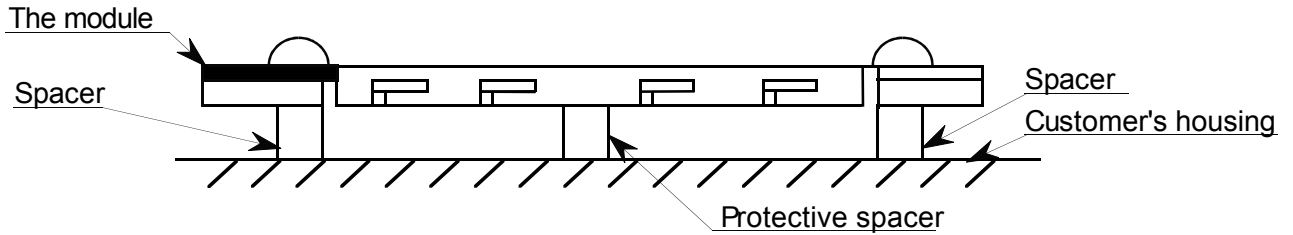

Example of mounting

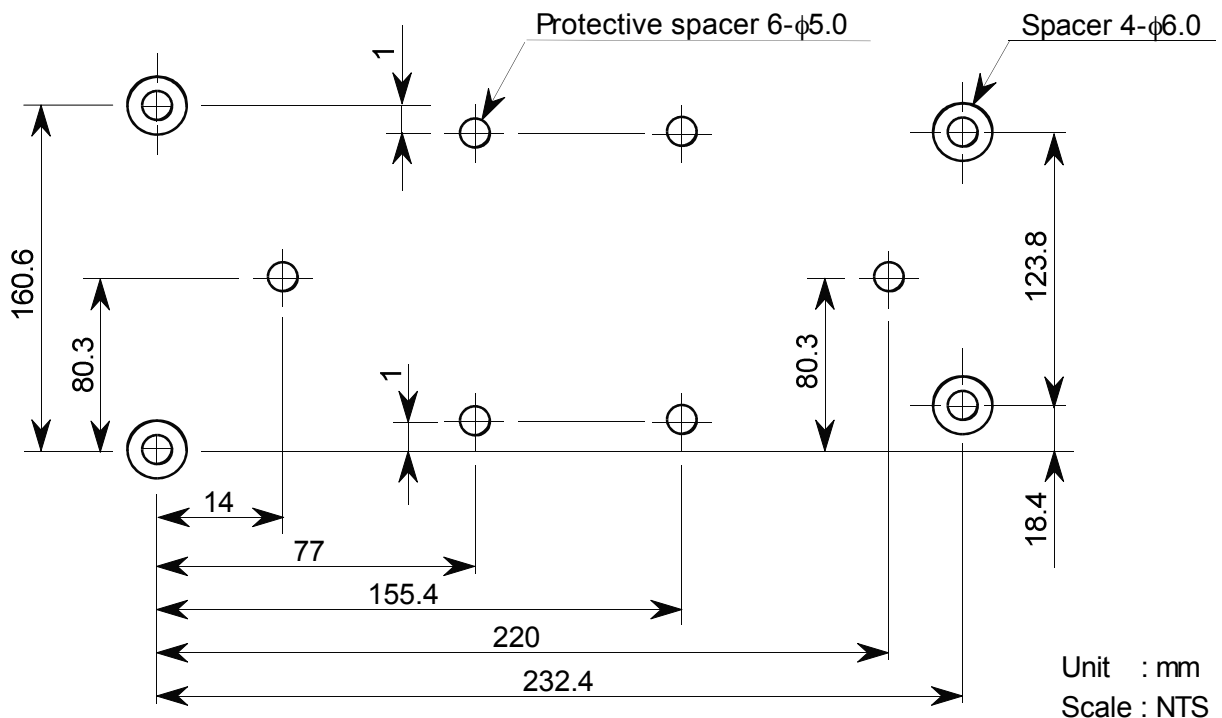

Location of spacers

- (1) To prevent the module cover from being pressed, the distance between the module and the fitting plate, which means the length of the spacers, should be shorter than 1.0mm.
- (2) We recommend you to use protective spacers in order to protect the module from any kinds of shocks to your set.
- (3) There are some parts (CFL, LSI, etc) on edge of our module. Please be careful with handling when you assemble (without any stress).
- (4) When you insert the connector to our module, please be careful with inserting it without slant.

Displays, Hitachi, Ltd.	Date	Sep. 6, '99	Sh. No.	3284PS 2711 - SX25S004 - 2	Page	11-1/4
----------------------------	------	-------------	------------	----------------------------	------	--------

(5) We recommend you to use the spacer in order to prevent coming off the suitable connector.

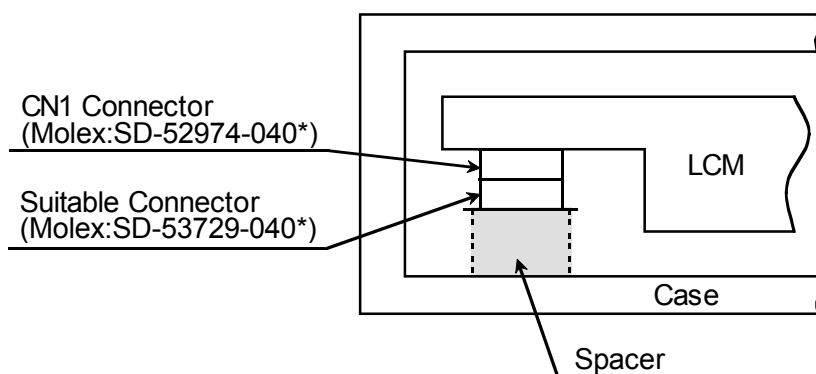

## 11.2 PRECAUTIONS AGAINST ELECTROSTATIC DISCHARGE

As this module contains C-MOS LSIs, it is not strong against electrostatic discharge. Make certain that the operator's body is connected to the ground through a list band etc. And don't touch I/F pins directly.

## 11.3 POWER ON SEQUENCE

Input signals should not be applied to LCD module before power supply voltage is applied and reaches to specified voltage ( $3.3 \pm 0.15V$ ).

If the above sequence is not kept, C-MOS LSIs of LCD module may be damaged due to latch up phenomenon.

#### 11.4 HANDLING PRECAUTIONS

- (1) Since the polarizer on the top, and the aluminum plate on the bottom tend to be easily damaged, they should be handled with full care so as not to get them touched, pushed or rubbed by a piece on glass, tweezers and anything else which are harder than a pencil lead 3H.
- (2) As the adhesives used for adhering upper/lower polarizers and aluminum plate are made of organic substances which will be deteriorated by a chemical reaction with such chemicals as acetone, toluene, ethanol and isopropyl alcohol. The following solvents are recommended for use : Normal hexane  
Please contact us when it is necessary for you to use chemicals other than the above.
- (3) Lightly wipe to clean the dirty surface with absorbent cotton or other soft material like chamois, soaked in the recommended chemicals without scrubbing it hardly.  
To prevent the display surface from damage and keep the appearance in good state, it is sufficient, in general, to wipe it with absorbent cotton.
- (4) Immediately wipe off saliva or water drop attached on the display area because it may cause deformation or faded color.
- (5) Foggy dew deposited on the surface may cause a damage, stain or dirt to the polarizer.  
When you need to take out the LCD module from some place at low temperature for test, etc. It is required to be warmed them up to be temperature higher than room temperature before taking them out.
- (6) Touching the display area or V/F pins with bare hands or contaminating them are prohibited, because the stain on the display area and poor insulation between terminals are often caused by being touched with bare hands.  
(Some cosmetics are detrimental to polarizers.)
- (7) In general, the glass is fragile so that it, especially on its periphery, tends to be cracked or chipped in handling. Please do not give the LCD module sharp shocks caused by falling etc.
- (8) Maximum pressure to the surface must be less than  $1.96 \times 10^4$  Pa (0.2kgf/cm<sup>2</sup>).  
And if the pressure area is less than 1cm<sup>2</sup>, maximum pressure must be less than 1.96N (0.2kgf).

Displays, Hitachi, Ltd.	Date	Sep. 6, '99	Sh. No.	3284PS 2711 - SX25S004 - 2	Page	11-3/4
----------------------------	------	-------------	------------	----------------------------	------	--------

### 11.5 OPERATION PRECAUTION

- (1) Using a LCM module beyond its maximum ratings may result in its permanent destruction. LCM module's should usually be used under recommended operating conditions shown in chapter 5. Exceeding any of these conditions may adversely affect its reliability.
- (2) Response time will be extremely delayed at lower temperature than the specified operating temperature range and on the other hand LCD's show dark blue color at higher temperature. However those phenomena do not mean defects of the LCD module. Those phenomena will disappear in the specified operating temperature range.
- (3) If the display area is pushed hard during operation, some display patterns will be abnormally displayed.
- (4) A slight dew depositing on terminals may cause electrochemical reaction which leads to terminal open circuit. Please operate the LCD module under the relative condition of 40°C 85%RH.

### 11.6 STORAGE

In case of storing LCD module for a long period of time (for instance, for years) for the purpose of replacement use, the following precautions necessary.

- (1) Store the LCD modules in a dark place ; do not expose them to sunlight or ultraviolet rays.
- (2) Keep the temperature between 10°C and 35°C at normal humidity.
- (3) Store the LCD modules in the container which is used for shipping from us.

### 11.7 SAFETY

- (1) The LCD modules include Cold Cathode Fluorescent Lamp (CFL). CFL contains a small amount of mercury. Please follow local ordinances or regulations for disposal.
- (2) It is recommendable to crash damaged or unnecessary LCD's into pieces and wash off liquid crystal by either of solvents such as acetone and ethanol, which should be burned up later.
- (3) When any liquid leaked out of a damaged glass cell comes in contact with your hands please wash it off well with soap and water.

Displays, Hitachi, Ltd.	Date	Sep. 6, '99	Sh. No.	3284PS 2711 - SX25S004 - 2	Page	11-4/4
----------------------------	------	-------------	------------	----------------------------	------	--------



## 12. DESIGNATION OF LOT MARK

### 12.1 LOT MARK

Lot mark is consisted of 4 digits for production lot and 6 or 7 digits for production control.

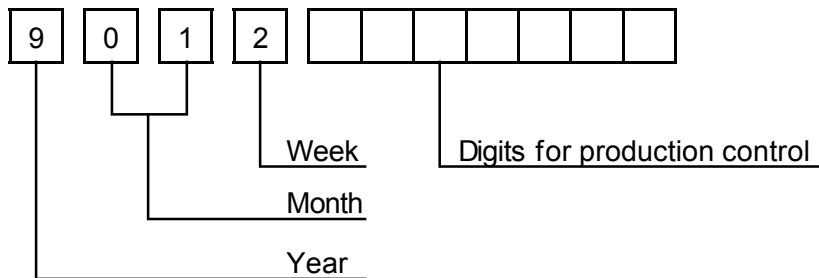

Year	Figure in lot mark
1999	9
2000	0
2001	1
2002	2

Month	Figure in lot mark	Month	Figure in lot mark
Jan.	01	July	07
Feb.	02	Aug.	08
Mar.	03	Sep.	09
Apr.	04	Oct.	10
May	05	Nov.	11
June	06	Dec.	12

Week (day in Calender)	Figure in lot mark
1~7	1
8~14	2
15~21	3
22~28	4
29~31	5

12.2 REVISION

REV No.	ITEM	LOT No.	PRODUCTION CONTROL No.
A			00001~

12.3 LOCATION OF LOT MARK

Either Label A or Label B is being attached on the back side of LCM.

Label A

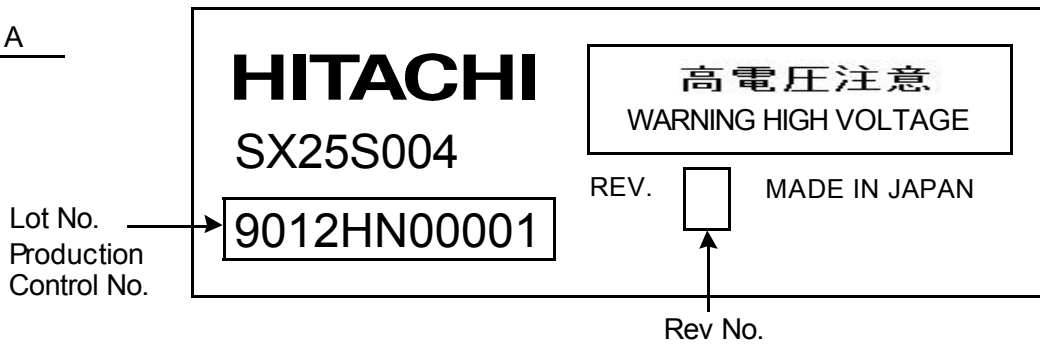

Label B

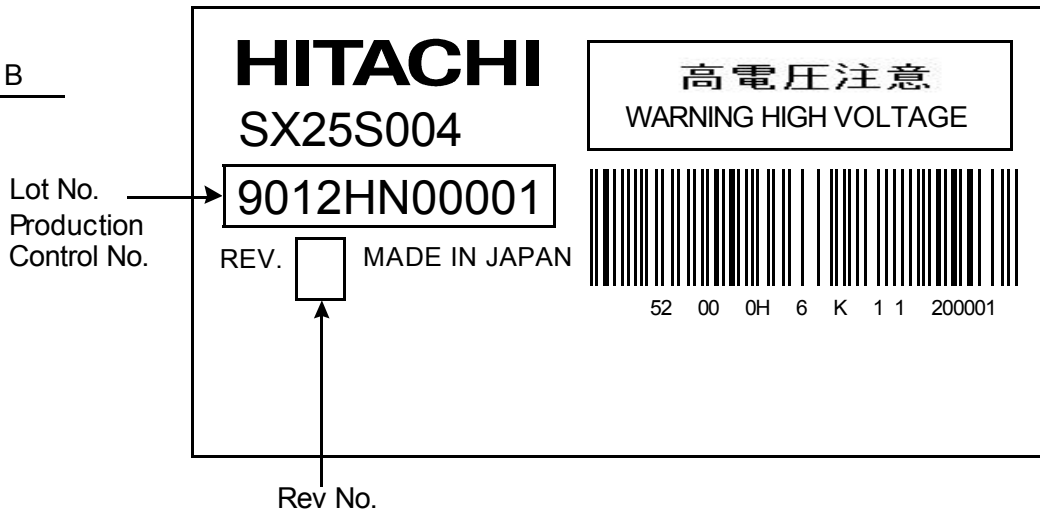

Label C

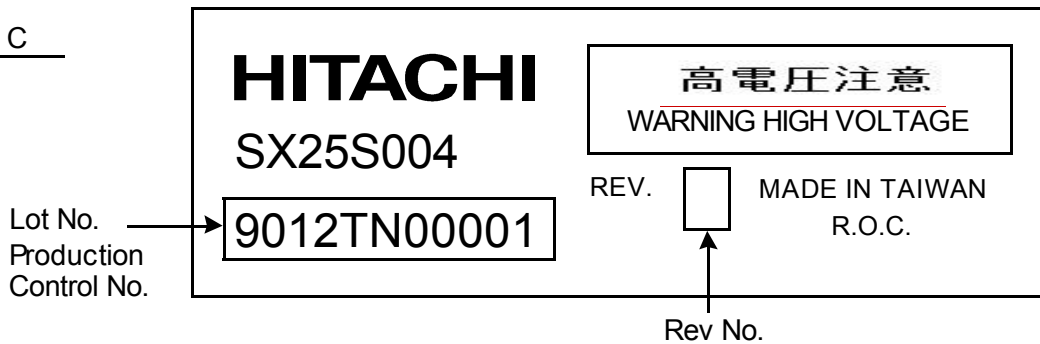

### 13. PRECAUTION FOR USE

- (1) A limit sample should be provided by the both parties on an occasion when the both parties agree to its necessity.  
Judgment by a limit sample shall take effect after the limit sample has been established and confirmed by the both parties.
- (2) On the following occasions, the handling of the problem should be decided through discussion and agreement between responsible persons of the both parties.
  - (1) When a question is arisen in the specifications.
  - (2) When a new problem is arisen which is not specified in the specifications.
  - (3) When an inspection specification change or operating condition change by customer is reported to HITACHI, and some problem is arisen in the specification due to the change.
  - (4) When a new problem is arisen at the customer's operating set for sample evaluation
- (3) Regarding the treatment for maintenance and repairing, both parties will discuss it in six months later after latest delivery of this product.

The precaution that should be observed when handling LCM have been explained above. If any points are unclear or if you have any requests, please contact Hitachi.

Displays, Hitachi, Ltd.	Date	Sep. 6, '99	Sh. No.	3284PS 2713 - SX25S004 - 2	Page	13-1/1
----------------------------	------	-------------	------------	----------------------------	------	--------