



晶采光電科技股份有限公司
AMPIRE CO., LTD.

SPECIFICATIONS FOR LCD MODULE

CUSTOMER	
CUSTOMER PART NO.	
AMPIRE PART NO.	AM-800480STMQW-TB0
APPROVED BY	
DATE	

Approved For Specifications

Approved For Specifications & Sample

AMPIRE CO., LTD.

2F., No.88, Sec. 1, Sintai 5th Rd., Sijhih City, Taipei County 221, Taiwan (R.O.C.)

台北縣汐止市新台五路一段 88 號 2 樓(東方科學園區 D 棟)

TEL:886-2-26967269 , FAX:886-2-26967196 or 26967270

APPROVED BY	CHECKED BY	ORGANIZED BY

RECORD OF REVISION

Revision Date	Page	Contents	Editor
2009/09/25	--	New Release	Emil

1. INTRODUCTION

Ampire Display Module is a color active matrix TFT-LCD that uses amorphous silicon TFT as a switching device. This model is composed of a TFT-LCD panel, timing controller and touch panel. This TFT-LCD has a high resolution (800(R.G.B) X 480) and can display up to 262,144 colors.

1-1. Features

- 7" WVGA (16:9 diagonal) configuration
- Input interface voltage : 3.3V
- Data enable mode

1-2. Applications

- Portable TV
- Car user DVD
- Industrial application
- HMI (Human machine interface)

2. PHYSICAL SPECIFICATIONS

Item	Specifications	unit
Display resolution(dot)	800RGB (W) x 480(H)	dots
Active area	152.4 (W) x 91.44 (H)	mm
Pixel pitch	0.1905 (W) x 0.1905 (H)	mm
Color configuration	R.G.B Vertical stripe	
Overall dimension	284.5(W)x104.44(H)x10.72 max(T)	mm
Weight	T.B.D.	g
Brightness	280 nit(typ)	cd/m ²
Contrast ratio	400 : 1	
Backlight unit	LED	
Display color	262,144	colors

3. ABSOLUTE MAX. RATINGS

ITEM	SYMBOL	MIN	MAX	UNIT
Power Supply Voltage for LCD	Vcc	-0.5	6.0	V
Signal input voltage	DCLK DE R0~R5 G0~G5 B0~b5	-0.5	VCC+0.5	V
Operation Temperature	Top	-20	70	°C
Storage Temperature	Tstg	-30	80	°C

The following values are maximum operation conditions , If exceeded , it may cause faulty operation or damage

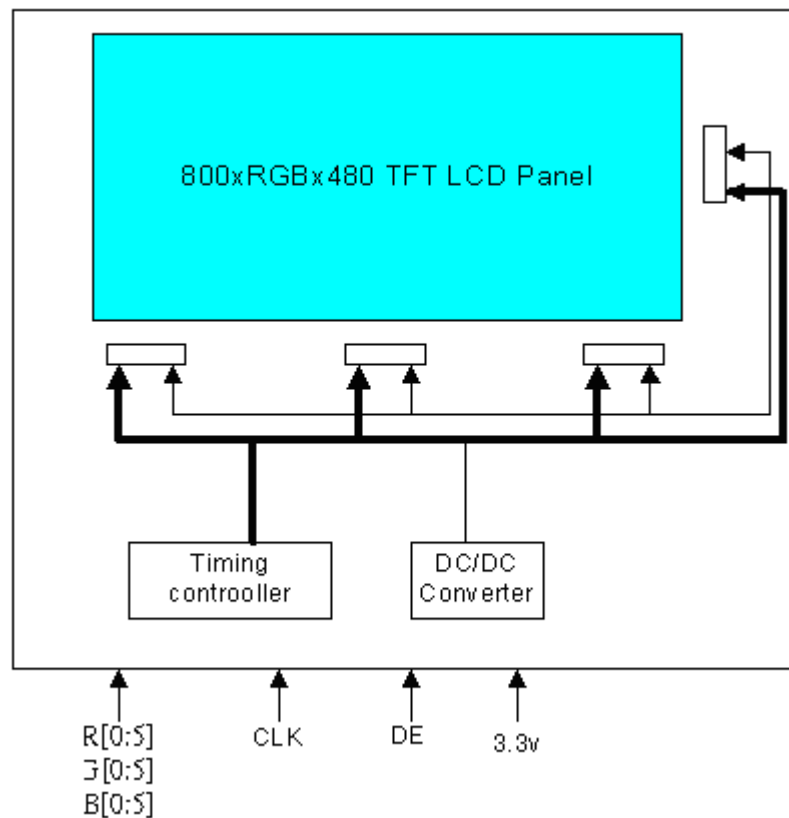

4. ELECTRICAL CHARACTERISTICS

4-1 TFT LCD Module voltage

ITEM		SYMBOL	MIN	TYP	MAX	UNIT	CONDITION
Power Supply Voltage For LCD		V _{CC}	3.0	3.3	3.6	V	
Power Supply Current For LCD		I _{CC}	-	150	250	mA	V _{CC} =3.3V
Power Supply Voltage For LED		V _{LED}	4.5	5.0	5.5	V	
Power Supply Current For LED		I _{LED}	-	380	-	mA	V _{LED} =5V V _{ADJ} =3.3V (duty 100%)
			-	650	-		V _{LED} =3.3V V _{ADJ} =3.3V (duty 100%)
LED Backlight Voltage		V _{BL}	-	9.9	-	V	IBL=160mA
LED Backlight Current		I _{BL}	-	160	-	mA	V _{LED} =5V V _{ADJ} =3.3V (duty 100%)
ADJ Input Voltage		V _{ADJ}	-	3.3	5	V	duty=100%
Logic Input Voltage	Input Voltage	V _{IN}	0	-	V _{CC}	V	
	Threshold Voltage(High)	V _{TH}	3.0	-	V _{CC}	V	
	Threshold Voltage(Low)	V _{TL}	GND	-	0.5	V	

Note 1:

VCC -dip condition:

- 1) When $2.7V \leq V_{CC} < 3.0V$, $t_d \leq 10ms$.
- 2) $V_{CC} > 3.0V$, VCC-dip condition should be same as VCC-turn-on condition.

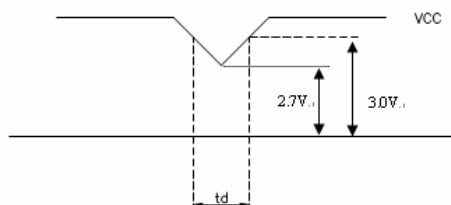

Note 2: The constant current source is needed for white LED back-light driving. When LCM is operated over 60°C ambient temperature, the I_{BL} of the LED back-light should be adjusted to 145mA max

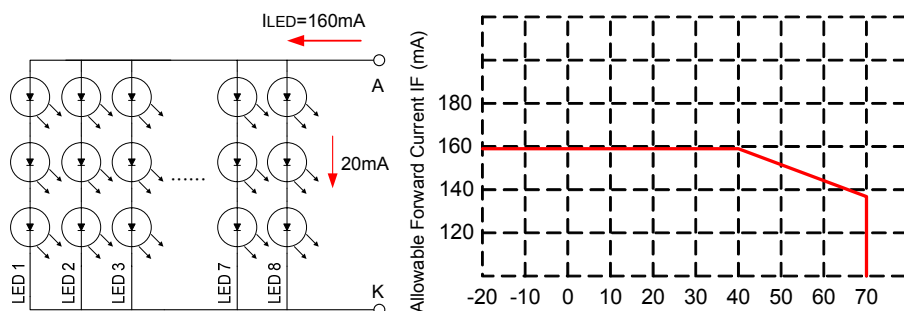

LED Light Bar Circuit

4-2 Touch Panel Electrical Specification

Parameter	Condition	Standard Value
Terminal Resistance	X Axis	200 ~ 900 Ω
	Y Axis	200 ~ 900 Ω
Insulating Resistance	DC 25 V	More than 20MΩ
Linearity	--	±1.5 %
Notes life by Pen	Note A	100,000 times(min)
Input life by finger	Note B	1,000,000 times (min)

Note A .

Notes area for pen notes life test is 10 x 9 mm.

Size of word is 7.5 x 6.72

Shape of pen end : R0.8

Load : 250 g

Note B

By Silicon rubber tapping at same point

Shape of rubber end : R8

Load : 200g

Frequency : 5 Hz

	Symbol	Function
1	Y2	Touch Panel Top Signal in X Axis
2	X2	Touch Panel Left Signal in Y Axis
3	Y1	Touch Panel Bottom Signal in X Axis
4	X1	Touch Panel Right Signal in Y Axis

5. INTERFACE

Pin no	Symbol	Function
1	LGND	LED Driver Ground
2	LGND	LED Driver Ground
3	ADJ	Adjust for LED Brightness
4	VLED	Power supply for LED (5V)
5	VLED	Power supply for LED (5V)
6	VLED	Power supply for LED (5V)
7	VCC	Power supply for LCD (3.3V)
8	VCC	Power supply for LCD (3.3V)
9	DE	Data Enable Timing Signal
10	SK/XL	For Touch panel used; (Keep NC). Keep these terminals NC for this model.
11	DO/XR	
12	DI/YB	
13	B5	Blue data (MSB)
14	B4	Blue data
15	B3	Blue data
16	GND	Ground
17	B2	Blue data
18	B1	Blue data
19	B0	Blue data (LSB)
20	GND	Ground
21	G5	Green data (MSB)
22	G4	Green data
23	G3	Green data
24	GND	Ground
25	G2	Green data
26	G1	Green data
27	G0	Green data (LSB)
28	GND	Ground
29	R5	Red data (MSB)
30	R4	Red data
31	R3	Red data
32	GND	Ground
33	R2	Red data
34	R1	Red data
35	R0	Red data (LSB)
36	TPCS/YU	For Touch panel used; (Keep No Connection). Keep these terminals NC for this model.
37	IRQ	
38	DCLK	Data Clock
39	GND	Ground
40	GND	Ground

NOTE :

Pin3: ADJ is PWM signal input. It is for brightness control.

ITEM	SYMBOL	MIN	TYP	MAX	UNIT
ADJ signal frequency	f_{PWM}	100	--	1K	Hz
ADJ signal logic level High	V_{IH}	2V	--	V_{LED} (5.0V)	V
ADJ signal logic level Low	V_{IL}	0	--	0.5	V

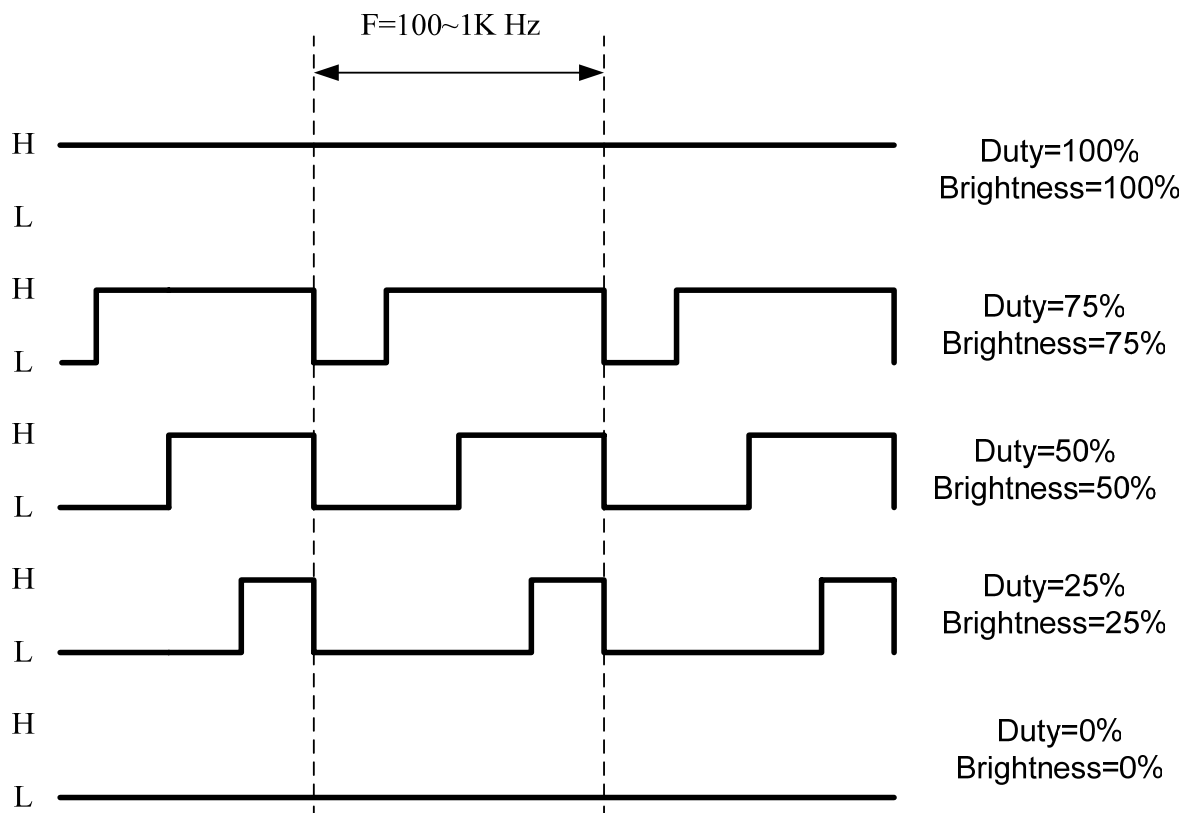

6. OPTICAL CHARACTERISTICS

Item		Symbol	Condition	Min.	Typ.	Max.	Unit	Note
Viewing Angle	Front	θf	$CR \geq 10$	50	60	--	deg.	(1)(2)(3)
	Back	θb		60	70	--		
	Left	θl		60	70	--		
	Right	θr		60	70	--		
Contrast ratio		CR	$\Theta = \Phi = 0^\circ$	250	400	--	--	(1)(3)
Response Time		T_r	$\Theta = \Phi = 0^\circ$	--	5	10	ms	(1)(4)
		T_f		--	11	16	ms	(1)(4)
Color chromaticity	White	W_x	$\Theta = \Phi = 0^\circ$	0.249	0.299	0.349	--	(1)
		W_y		0.278	0.328	0.378		
	Red	R_x		0.522	0.572	0.622		
		R_y		0.308	0.358	0.408		
	Green	G_x		0.291	0.341	0.391		
		G_y		0.534	0.584	0.634		
	Blue	B_x		0.082	0.132	0.182		
		B_y		0.083	0.133	0.183		
Luminance		L	$\Theta = \Phi = 0^\circ$	240	280	--	cd/m ²	(1)(5)
Luminance Uniformity		ΔL	$\Theta = \Phi = 0^\circ$	70	--	--	%	(1)(5)(6)

Note 1: $T_a = 25^\circ\text{C}$. To be measured on the center area of panel after 10 minutes operation.

Note 2: Definition of Viewing Angle

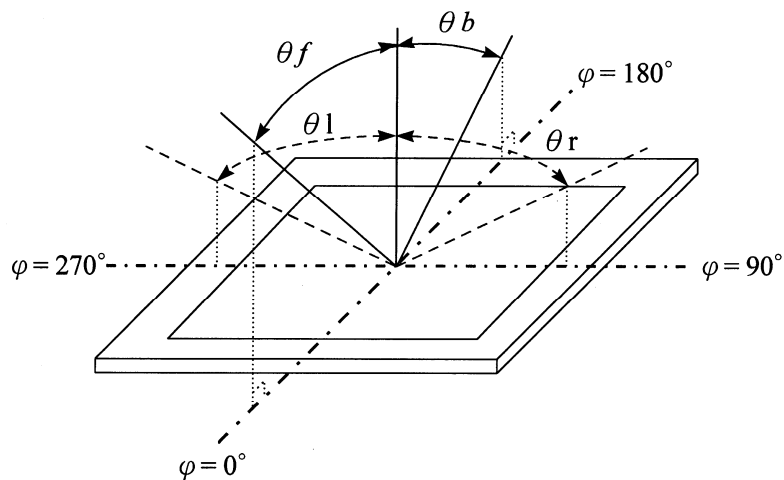

Note 3: Definition of contrast ratio:

Contrast ratio is calculated with the following formula.

$$\text{Contrast ratio(CR)} = \frac{\text{Photo detector output when LCD is at "White" state}}{\text{Photo detector Output when LCD is at "Black" state}}$$

Note 4: Definition of response time:

The output signals of photo detector are measured when the input signals are changed from "black" to "white"(falling time) and from "white" to "black" (rising time) respectively. The response time is defined as the time interval between the 10% and 90% of amplitudes. Refer to figure as below.

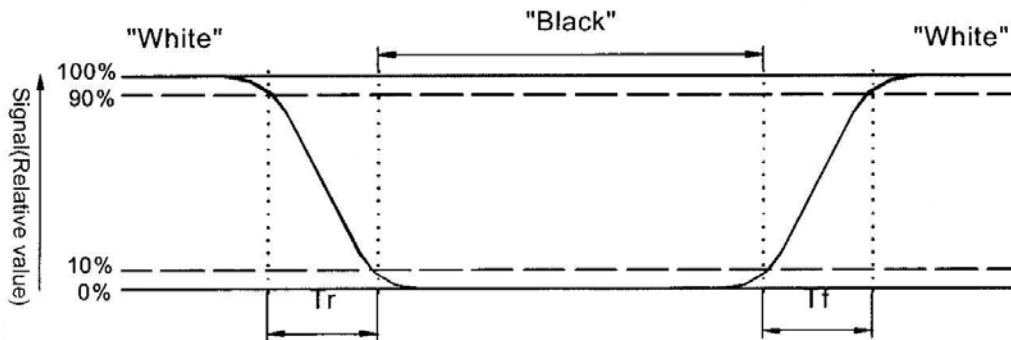

Note 5 : Luminance is measured at point 5 of the display.

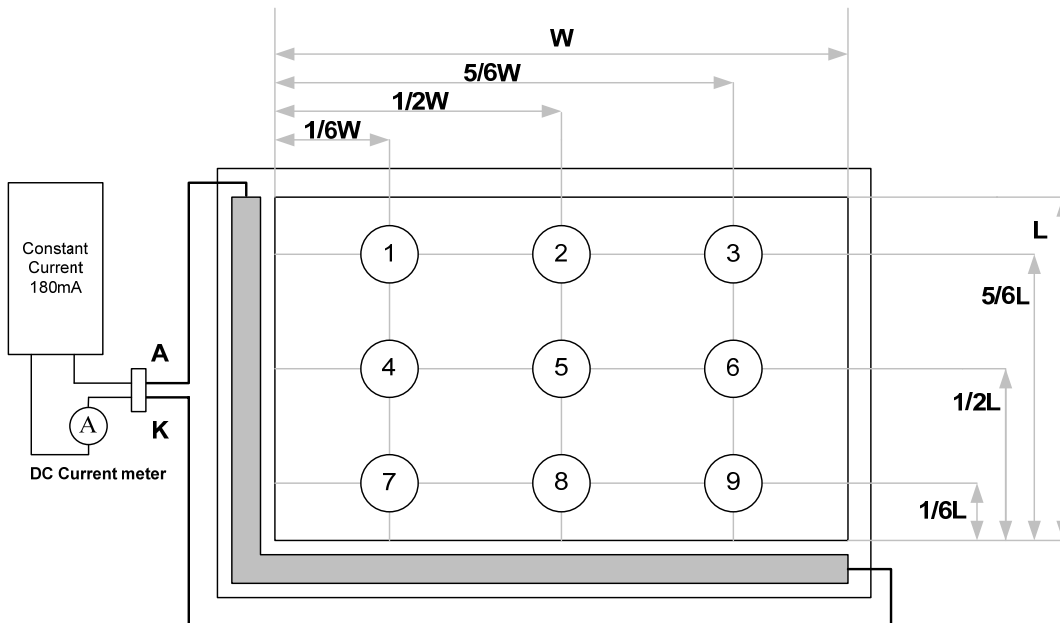

Note 6 : Definition of Luminance Uniformity

$$\Delta L = [L(\text{min.}) \text{ of 9 points} / L(\text{max.}) \text{ of 9 points}] \times 100\%$$

7. INPUT SIGNAL (DE ONLY MODE)

Parameter	Symbol	Rating			Unit
		Min.	Typ.	Max.	
Data setup time	Tdsu	6	-	-	ns
Data hold time	Tdhd	6	-	-	Tcph
DE setup time	Tesu	6	-	-	Tcph
CLK frequency	F _{CPH}		33.26		MHz
CLK period	T _{CPH}		30.06		ns
CLK pulse duty	T _{CWH}	40	50	60	%
DE period	T _{DEH} +T _{DEL}	1000	1056	1200	T _{CPH}
DE pulse width	T _{DEH}	-	800	-	T _{CPH}
DE frame blanking	T _{DEB}	10	45	110	T _{DEH} +T _{DEL}
DE frame width	T _{DE}	-	480	-	T _{DEH} +T _{DEL}

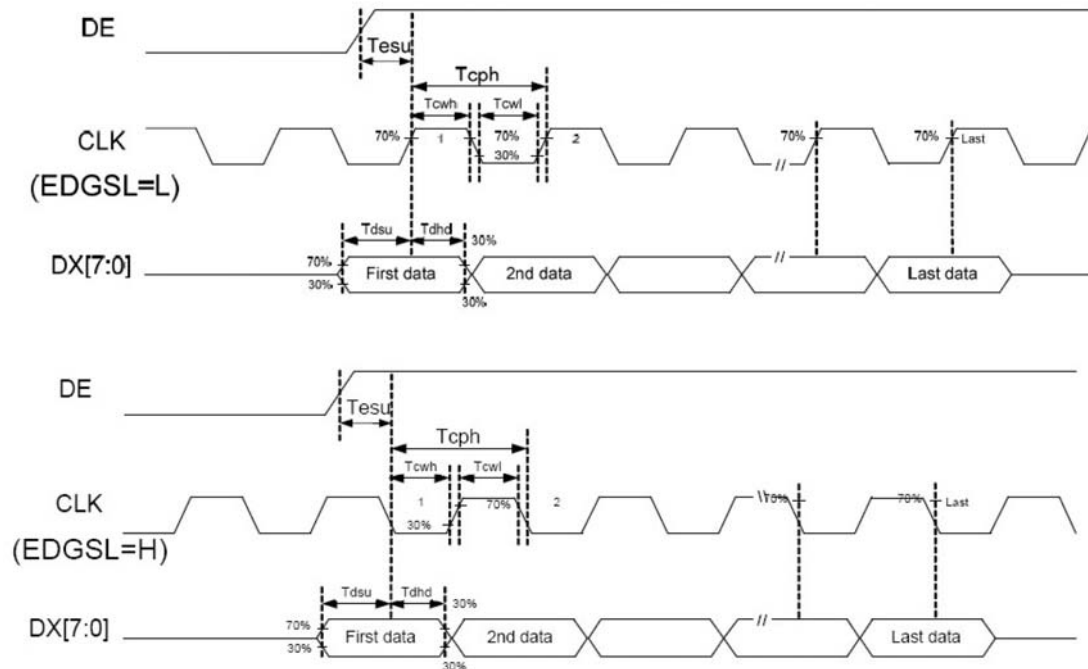

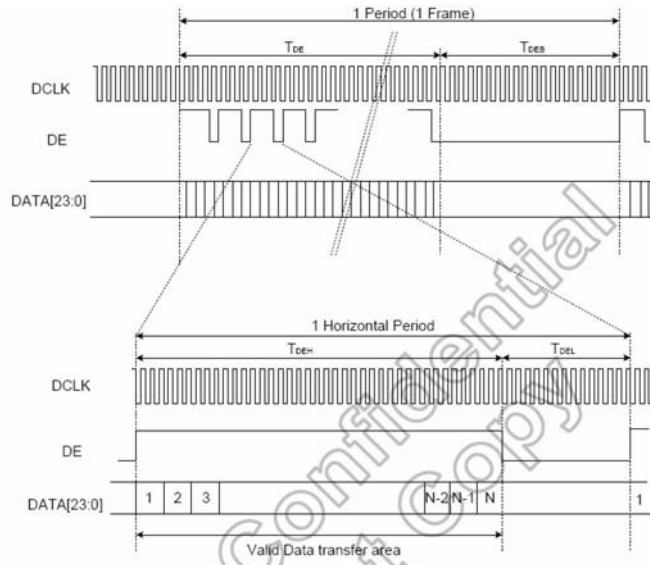

Power Sequence

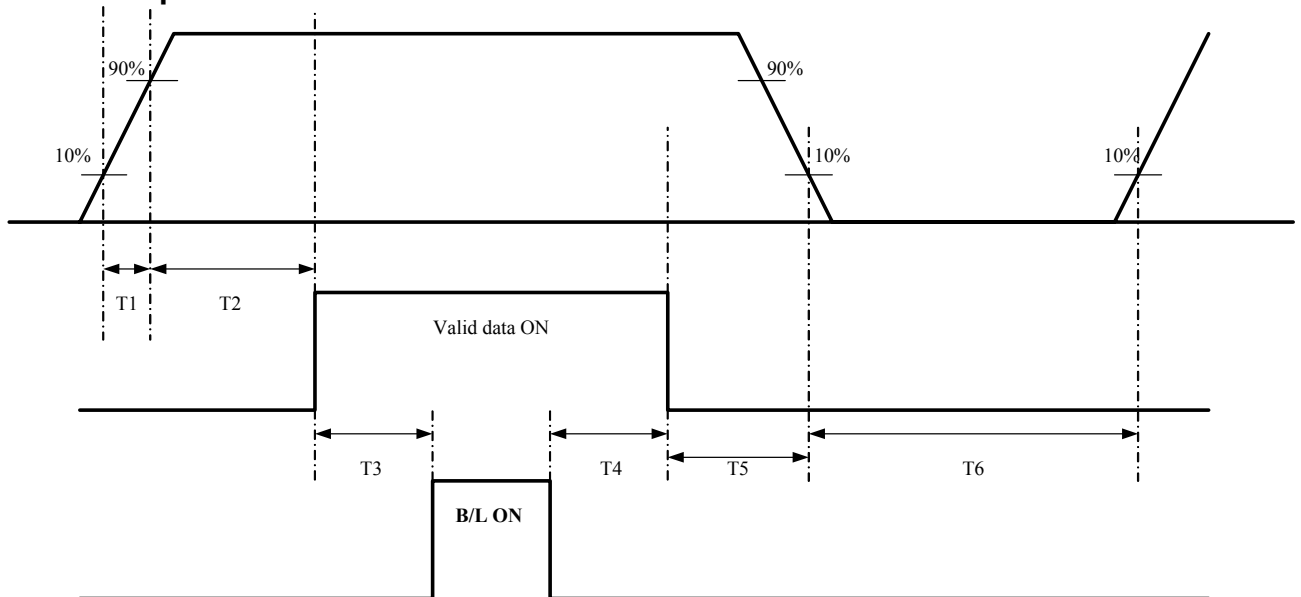

parameter	SPEC			Unit
	Min.	Typ.	Max.	
T1	1		2	ms
T2	0	60		ms
T3	200			ms
T4	200			ms
T5	1			ms
T6	1000			ms

9. QUALITY AND RELIABILITY

9.1 TEST CONDITIONS

Tests should be conducted under the following conditions :

Ambient temperature : $25 \pm 5^{\circ}\text{C}$

Humidity : $60 \pm 25\% \text{ RH}$.

9.2 SAMPLING PLAN

Sampling method shall be in accordance with MIL-STD-105E , level II, normal single sampling plan .

9.3 ACCEPTABLE QUALITY LEVEL

A major defect is defined as one that could cause failure to or materially reduce the usability of the unit for its intended purpose. A minor defect is one that does not materially reduce the usability of the unit for its intended purpose or is an infringement from established standards and has no significant bearing on its effective use or operation.

9.4 APPEARANCE

An appearance test should be conducted by human sight at approximately 30 cm distance from the LCD module under florescent light. The inspection area of LCD panel shall be within the range of following limits.

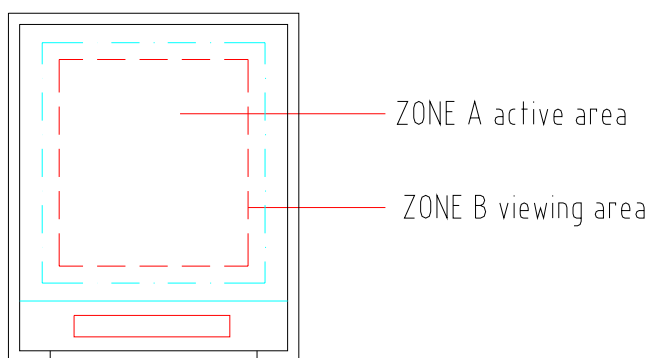

9.5 Incoming Inspection Standard

Defect Type			Limit			Note		
Visual Defect	Internal	Spot	$\phi < 0.15\text{mm}$		Ignore	(1)		
			$0.15\text{mm} \leq \phi \leq 0.5\text{mm}$		$N \leq 4$			
			$0.5\text{mm} < \phi$		$N=0$			
		Fiber	$0.1\text{mm} < W \leq 0.5\text{mm},$ $L \leq 1.5\text{mm}$		$N \leq 4$	(1)		
			$1.0\text{mm} < W, 1.5\text{mm} < L$		$N=0$			
		Polarizer Bubble	$\phi < 0.15\text{mm}$		Ignore	(1)		
			$0.15\text{mm} \leq \phi \leq 0.5\text{mm}$		$N \leq 4$			
			$0.5\text{mm} < \phi$		$N=0$			
		Mura	It' OK if mura is slight visible through 6%ND filter					
Electrical Defect	Bright Dot	A Grade			B Grade			
		C Area	O Area	Total	C Area	O Area	Total	(3)
		$N \leq 0$	$N \leq 2$	$N \leq 2$	$N \leq 2$	$N \leq 3$	$N \leq 5$	(2)
	Dark Dot	$N \leq 2$	$N \leq 4$	$N \leq 4$	$N \leq 3$	$N \leq 5$	$N \leq 8$	
	Total Dot	$N \leq 4$			$N \leq 5$	$N \leq 6$	$N \leq 8$	(2)
	Two Adjacent Dot	$N \leq 0$	$N \leq 1$ pair	$N \leq 1$ pair	$N \leq 1$ pair	$N \leq 1$ pair	$N \leq 1$ pair	(4)
	Three or More Adjacent Dot	Not Allowed						
	Line Defect	Not Allowed						

- (1) One pixel consists of 3 sub-pixels, including R,G, and B dot.(Sub-pixel = Dot)
 (2) LITTLE BRIGHT DOT acceptable under 6% ND-Filter

[Note1] W : Width[mm], L : Length[mm], N : Number, ϕ : Average Diameter

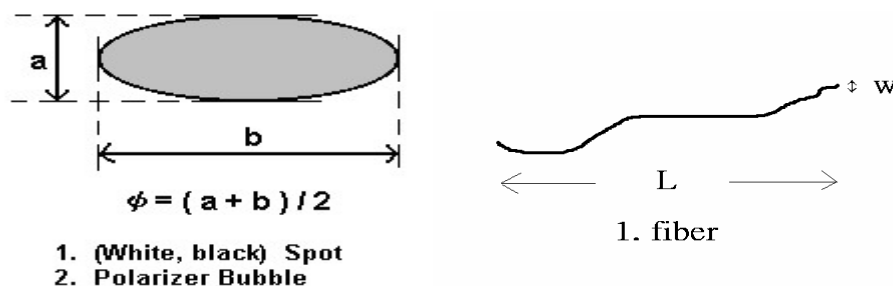

[Note2] Bright dot is defined through 6% transmission ND Filter as following.

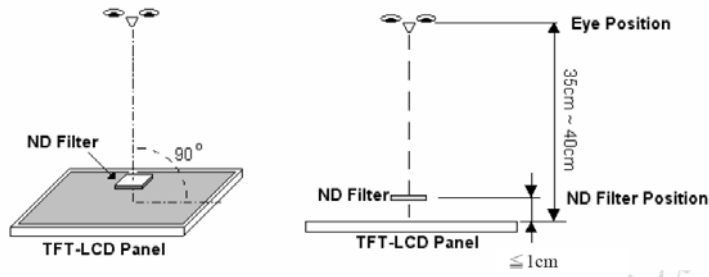

[Note3]

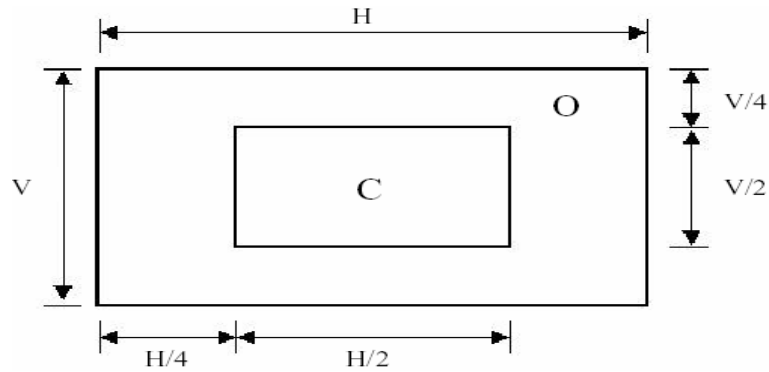

C Area: Center of display area
O Area: Outer of display area

[Note4]

Judge defect dot and adjacent dot as following. Allow below (as A, B, C and D status) adjacent defect dots, including bright and dark adjacent dot. And they will be counted 2 defect dots in total quantity.

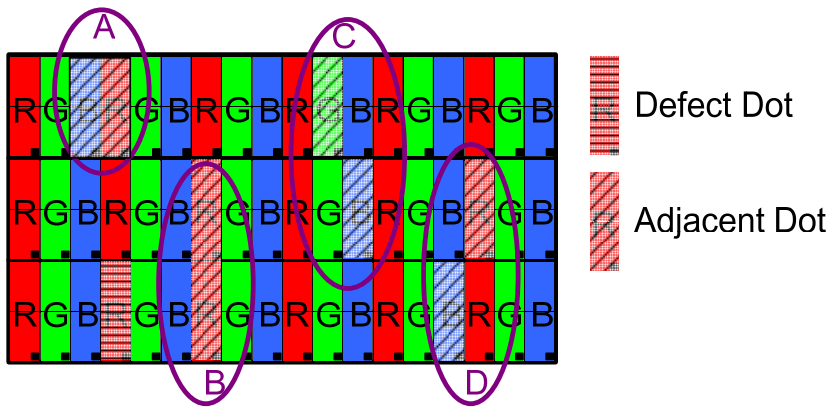

- (1) The defects that are not defined above and considered to be problem shall be reviewed and discussed by both parties.
- (2) Defects on the Black Matrix, out of Display area, are not considered as a defect or counted.

9.6 RELIABILITY TEST CONDITIONS

Test Item	Test Conditions	Note
High Temperature Operation	70±3°C , t=96 hrs	
Low Temperature Operation	-20±3°C , t=96 hrs	
High Temperature Storage	80±3°C , t=96 hrs	1,2
Low Temperature Storage	-30±3°C , t=96 hrs	1,2
Thermal Shock Test	-30°C ~ 25°C ~ 80°C 30 m in. 5 min. 30 min. (1 cycle) Total 5 cycle	1,2
Humidity Test	40 °C, Humidity 90%, 96 hrs	1,2
Vibration Test (Packing)	Sweep frequency : 10 ~ 55 ~ 10 Hz/1min Amplitude : 0.75mm Test direction : X.Y.Z/3 axis Duration : 30min/each axis	2

Note 1 : Condensation of water is not permitted on the module.

Note 2 : The module should be inspected after 1 hour storage in normal conditions

(15-35°C , 45-65%RH).

Definitions of life end point :

- Current drain should be smaller than the specific value.
- Function of the module should be maintained.
- Appearance and display quality should not have degraded noticeably.
- Contrast ratio should be greater than 50% of the initial value.

10. USE PRECAUTIONS

10-1 Handling precautions

- (1) The polarizing plate may break easily so be careful when handling it. Do not touch, press or rub it with a hard-material tool like tweezers.
- (2) Do not touch the polarizing plate surface with bare hands so as not to make it dirty. If the surface or other related part of the polarizing plate is dirty, soak a soft cotton cloth or chamois leather in benzene and wipe off with it. Do not use chemical liquids such as acetone, toluene and isopropyl alcohol. Failure to do so may bring chemical reaction phenomena and deteriorations.
- (3) Remove any spit or water immediately. If it is left for hours, the suffered part may deform or decolorize.
- (1) If the LCD element breaks and any LC stuff leaks, do not suck or lick it. Also if LC stuff is stuck on your skin or clothing, wash thoroughly with soap and water immediately.

10-2 Installing precautions

- (1) The PCB has many ICs that may be damaged easily by static electricity. To prevent breaking by static electricity from the human body and clothing, earth the human body properly using the high resistance and discharge static electricity during the operation. In this case, however, the resistance value should be approx. $1M\Omega$ and the resistance should be placed near the human body rather than the ground surface. When the indoor space is dry, static electricity may occur easily so be careful. We recommend the indoor space should be kept with humidity of 60% or more. When a soldering iron or other similar tool is used for assembly, be sure to earth it.
- (2) When installing the module and ICs, do not bend or twist them. Failure to do so may crack LC element and cause circuit failure.
- (3) To protect LC element, especially polarizing plate, use a transparent protective plate (e.g., acrylic plate, glass etc) for the product case.
- (4) Do not use an adhesive like a both-side adhesive tape to make LCD surface (polarizing plate) and product case stick together. Failure to do so may cause the polarizing plate to peel off

10-3 Storage precautions

- (1) Avoid a high temperature and humidity area. Keep the temperature between 0°C and 35°C and also the humidity under 60%.
- (2) Choose the dark spaces where the product is not exposed to direct sunlight or fluorescent light.
- (3) Store the products as they are put in the boxes provided from us or in the same conditions as we recommend.

10-4 Operating precautions

(1) Do not boost the applied drive voltage abnormally. Failure to do so may break ICs. When applying power voltage, check the electrical features beforehand and be careful. Always turn off the power to the LC module controller before removing or inserting the LC module input connector. If the input connector is removed or inserted while the power is turned on, the LC module internal circuit may break.

(2) The display response may be late if the operating temperature is under the normal standard, and the display may be out of order if it is above the normal standard. But this is not a failure; this will be restored if it is within the normal standard.

(3) The LCD contrast varies depending on the visual angle, ambient temperature, power voltage etc. Obtain the optimum contrast by adjusting the LC drive voltage.

(4) When carrying out the test, do not take the module out of the low-temperature space suddenly. Failure to do so will cause the module condensing, leading to malfunctions.

(5) Make certain that each signal noise level is within the standard (L level: $0.2V_{dd}$ or less and H level: $0.8V_{dd}$ or more) even if the module has functioned properly. If it is beyond the standard, the module may often malfunction. In addition, always connect the module when making noise level measurements.

(6) The CMOS ICs are incorporated in the module and the pull-up and pull-down function is not adopted for the input so avoid putting the input signal open while the power is ON.

(7) The characteristic of the semiconductor element changes when it is exposed to light emissions, therefore ICs on the LCD may malfunction if they receive light emissions. To prevent these malfunctions, design and assemble ICs so that they are shielded from light emissions.

(8) Crosstalk occurs because of characteristics of the LCD. In general, crosstalk occurs when the regularized display is maintained. Also, crosstalk is affected by the LC drive voltage. Design the contents of the display, considering crosstalk.

10-5 Other

(1) Do not disassemble or take the LC module into pieces. The LC modules once disassembled or taken into pieces are not the guarantee articles.

(2) The residual image may exist if the same display pattern is shown for hours. This residual image, however, disappears when another display pattern is shown or the drive is interrupted and left for a while. But this is not a problem on reliability.

(3) AMIPRE will provide one year warranty for all products and three months warranty for all repairing products..

11. OUTLINE DIMENSION

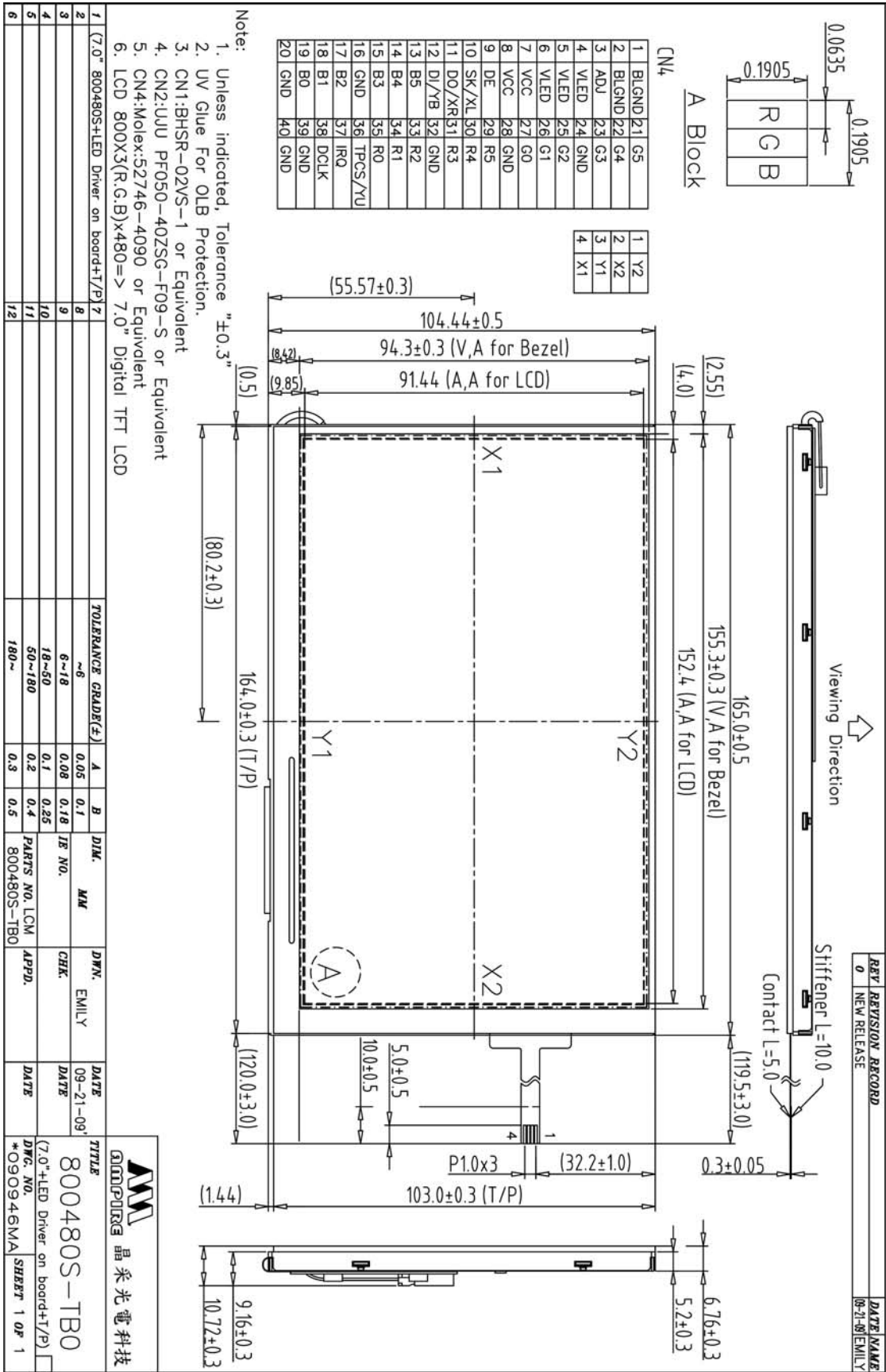

REV	REVISION RECORD	DATE	NAME
0	NEW RELEASE	09-21-09	EMILY

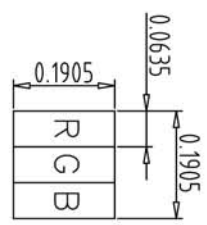

CN4 A Block

1	BLGND	21	G5
2	BLGND	22	G4
3	A0J	23	G3
4	VLED	24	GND
5	VLED	25	G2
6	VLED	26	G1
7	VCC	27	G0
8	VCC	28	GND
9	DE	29	R5
10	SK/XL	30	R4
11	DO/XR	31	R3
12	DI/YB	32	GND
13	B5	33	R2
14	B4	34	R1
15	B3	35	RO
16	GND	36	TPCS/YU
17	B2	37	IRQ
18	B1	38	DCLK
19	B0	39	GND
20	GND	40	GND

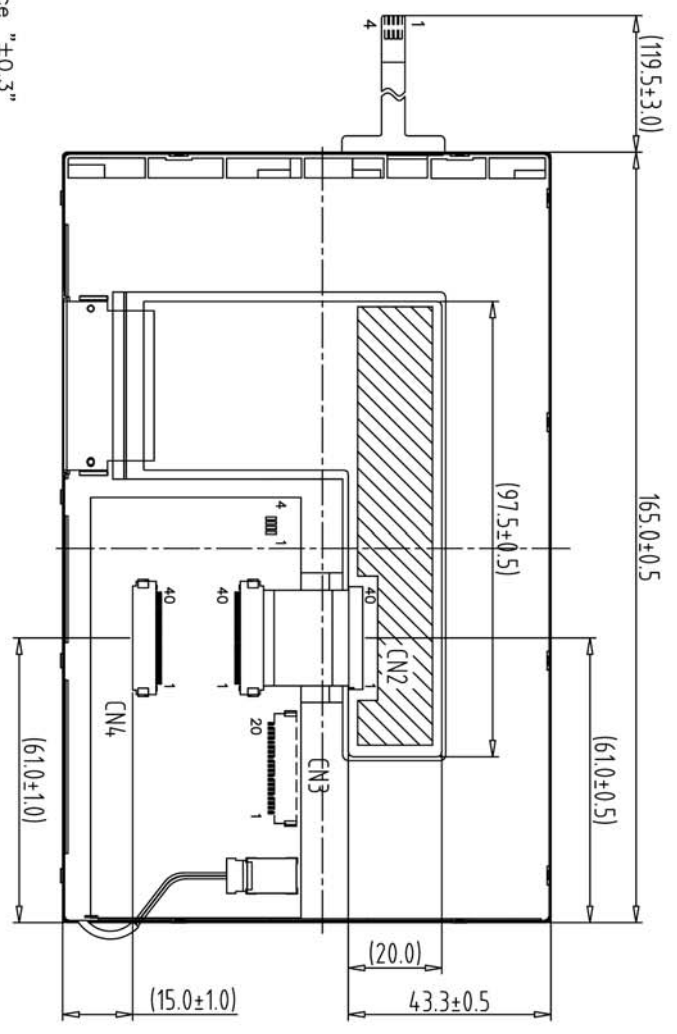

Back View

1	Y2
2	X2
3	Y1
4	X1

- Note:
1. Unless indicated, Tolerance "±0.3"
 2. UV Glue For OLB Protection.
 3. CN1:BHSR-02VS-1 or Equivalent
 4. CN2:JUJ PF050-40ZSG-F09-S or Equivalent
 5. CN4:Molex:52746-4090 or Equivalent
 6. LCD 800X3(R;G;B)x480=> 7.0" Digital TFT LCD

1	(7.0" 800480S+LED Driver on board+T/P)	7	TOLERANCE GRADE(%)	A	B	DIM.	MM	DWN.	EMILY	DATE	TITLE
2		8	~6	0.05	0.1					09-21-09	800480S-TB0
3		9	6~18	0.08	0.18	IR NO.		CHK.		DATE	
4		10	18~50	0.1	0.25					DATE	
5		11	50~180	0.2	0.4	PARTS NO./QM-1		APPD.		DATE	
6		12	180~	0.3	0.5	800480S-TB0				DATE	

晶采光電科技
800480S-TB0
 (7.0"+LED Driver on board+T/P)
 DWG. NO. *090947MA SHEET 1 OF 1