

Doc. Version	0.3
Total Pages	18
Date	2006/10/30

Product Specification

5.0" COLOR TFT-LCD MODULE

MODEL NAME: A050FW01 V1

<◆>Preliminary Specification

< >Final Specification

© 2006 AU Optronics

All Rights Reserved.

Record of Revision

Version	Revise Date	Page	Content
0	16/Aug./2006		First draft.
0.1	13/Oct./2006	20	Outline drawing: TBD
0.2	23/Oct./2006	19	Update outline drawing.
0.3	30/Oct./2006	7,9 18	Delete original outline drawing. Update outline drawing.

Internal Use Only

Contents

<u>A. PHYSICAL SPECIFICATIONS</u>	4
<u>B. ELECTRICAL SPECIFICATIONS</u>	5
1. FPC PIN ASSIGNMENT	5
2. ABSOLUTE MAXIMUM RATINGS	7
<u>C. ELECTRICAL CHARACTERISTICS</u>	7
1. TFT- LCD TYPICAL OPERATION CONDITION	7
2. BACKLIGHT DRIVING CONDITIONS	7
3. SUGGESTED APPLICATION CIRCUIT	8
4. AC TIMING	9
3.4.1 TIMING DIAGRAM	9
B. TIMING CONDITION	10
5. POWER ON/OFF SEQUENCE	10
<u>D. OPTICAL SPECIFICATION</u>	11
<u>E. TOUCH SCREEN PANEL SPECIFICATIONS</u>	13
1. FPC PIN ASSIGNMENT	13
2. ELECTRICAL CHARACTERISTICS	13
3. MECHANICAL CHARACTERISTICS	14
4. LIFE TEST CONDITION	14
5. ATTENTION	15
<u>F. RELIABILITY TEST ITEMS:</u>	16
<u>G. PACKING FORM</u>	17
<u>H. OUTLINE DRAWING:</u>	18

A. Physical specifications

NO.	Item	Specification	Remark
1	Display Resolution (dot)	480RGB (H) X 272 (V)	
2	Active Area (mm)	110.88 (H) X 62.83 (V)	
3	Screen Size (inch)	5.0" (Diagonal)	
4	Dot Pitch (mm)	0.077 (H) X 0.231 (V)	
5	Color Configuration	R. G. B. Stripe	Note 1
6	Color Depth	16.7M Colors	Note 2
7	Overall Dimension (mm)	120.7 (H) X 75.8 (V) X 4.21 (T)	Note 3
8	Weight (g)	TBD (Typical)	
9	Touch Panel surface treatment	Hard Coating 3H	
10	Display Mode	Normally White	

Note 1: Below figure shows dot stripe arrangement.

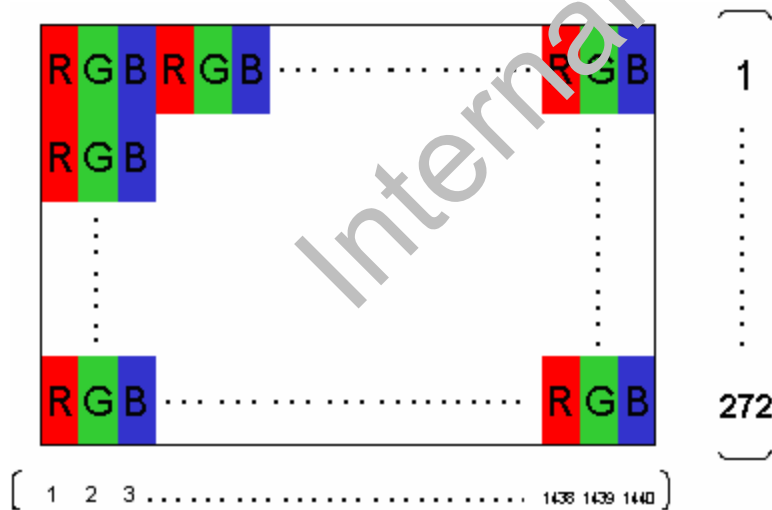

Note 2: Full color display depends on 8-bit data signal (pin 5~28).

Note 3: Not include FPC. Refer to next page to get further information

B. Electrical Specifications

1. FPC Pin Assignment

Pin No.	Symbol	Type	Description	Remark
1	GND	P	Ground	
2	GND	P	Ground	
3	VDD	P	Power supply	
4	VDD	P	Power supply	
5	R0	I	Red data (LSB)	
6	R1	I	Red data	
7	R2	I	Red data	
8	R3	I	Red data	
9	R4	I	Red data	
10	R5	I	Red data	
11	R6	I	Red data	
12	R7	I	Red data (MSB)	
13	G0	I	Green data (LSB)	
14	G1	I	Green data	
15	G2	I	Green data	
16	G3	I	Green data	
17	G4	I	Green data	
18	G5	I	Green data	
19	G6	I	Green data	
20	G7	I	Green data (MSB)	
21	B0	I	Blue data (LSB)	
22	B1	I	Blue data	
23	B2	I	Blue data	
24	B3	I	Blue data	
25	B4	I	Blue data	

Pin No.	Symbol	Type	Description	Remark
26	B5	I	Blue data	
27	B6	I	Blue data	
28	B7	I	Blue data (MSB)	
29	GND	P	Ground	
30	DCLK	I	Pixel clock	
31	DISP	I	DISP : 'L' Display OFF DISP : 'H' Display ON	
32	HSYNC	I	Horizontal Sync Signal	
33	VSYNC	I	Vertical Sync Signal	
34	DE	I	Data Enable	
35	U/D	I	Shift Up or Down Control	
36	NC		None Connect	
37	GND	P	Ground	
38	GND	P	Ground	
39	TP_R	O	Touch Panel Right Signal	
40	TP_B	O	Touch Panel Bottom Signal	
41	TP_L	O	Touch Panel Left Signal	
42	TP_U	O	Touch Panel Up Signal	
43	GND	P	Ground	
44	GND	P	Ground	
45	GND	P	Ground	
46	VLED-	P	LED cathode	
47	VLED+	P	LED anode	
48	GND	P	Ground	
49	GND	P	Ground	
50	GND	P	Ground	

Note : I: Input; O: Output; P: Power.

2. Absolute Maximum Ratings

Item	Symbol	Min.	Max.	Unit	Remark
Power voltage	V _{cc}	-0.3	4.5	V	Note 1
Input signal voltage	V _i	-0.3	V _{cc} + 0.3	V	
Operating temperature	T _a	-30	85	°C	Ambient temperature
Storage temperature	T _{stg}	-55	125	°C	Ambient temperature

Note 1: Functional operation should be restricted under normal ambient temperature.

C. Electrical Characteristics

The following items are measured under stable condition and suggested application circuit.

1. TFT- LCD Typical Operation Condition

Item	Symbol	Min.	Typ.	Max.	Unit	Remark
Power supply	V _{cc}	TBD	TBD	TBD	V	
Input high voltage	V _h	0.7*V _{cc}	-	V _{cc}	V	
Input low voltage	V _l	0	-	0.3*V _{cc}		
Vsync Frequency	f _v		TBD		Hz	
Hsync Frequency	f _H		TBD		kHz	
Dot Frequency	f _{DCLK}		9.0	15.0	MHz	

2. Backlight Driving Conditions

Parameter	Symbol	Min.	Typ.	Max.	Unit	Remark
LED Current	I _L	-	20	-	mA	single seral
LED Voltage	V _L	-	33	-	V	single seral
LED Life Time	L _L	-	-	-	Hr	Note 2, 3

Note 1: LED backlight is 10 LEDs.

Note 2 :Define "LED Lifetime": brightness is decreased to 50% of the initial value. LED Lifetime is restricted under normal condition, ambient temperature = 25°C and LED current = 20mA.

Note 3: If it uses larger LED current I_L more than 20mA, it maybe decreases the LED lifetime.

3. Suggested Application Circuit

3.3.1 Suggested Application Circuit

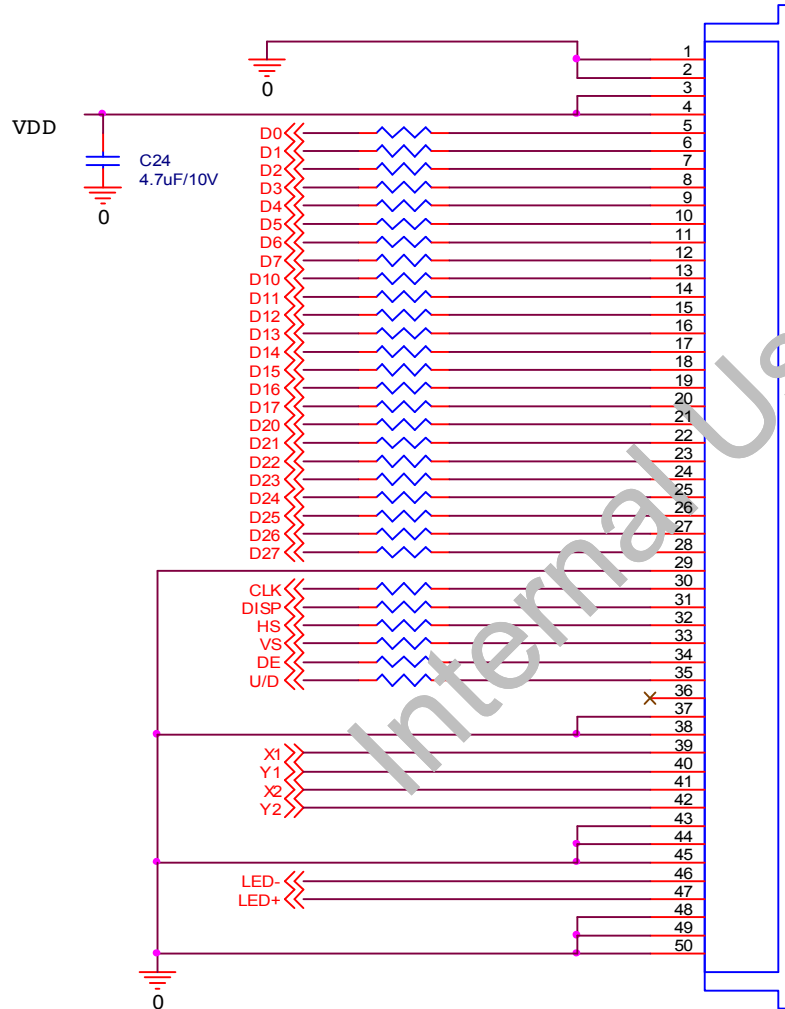

NOTE: Resistors = 120ohm

4. AC Timing

3.4.1 Timing Diagram

3.4.1.1 Vertical Timing of Input

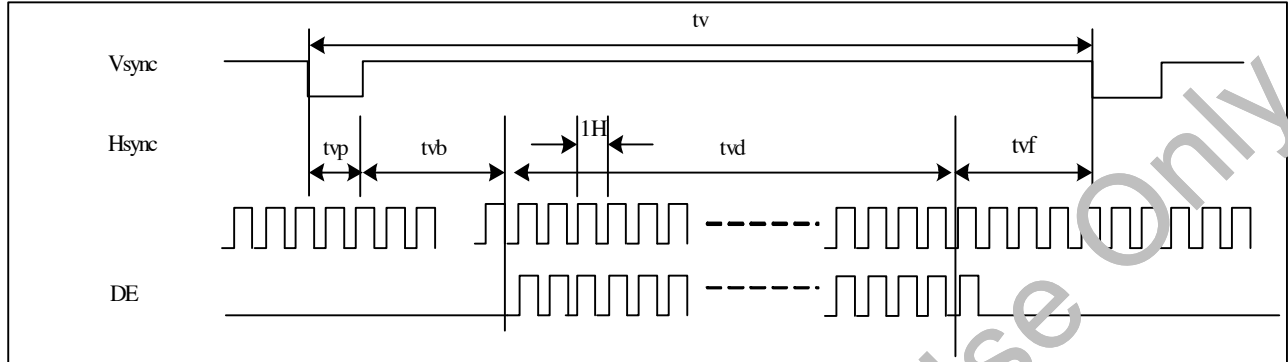

2 Horizontal Timing of Input

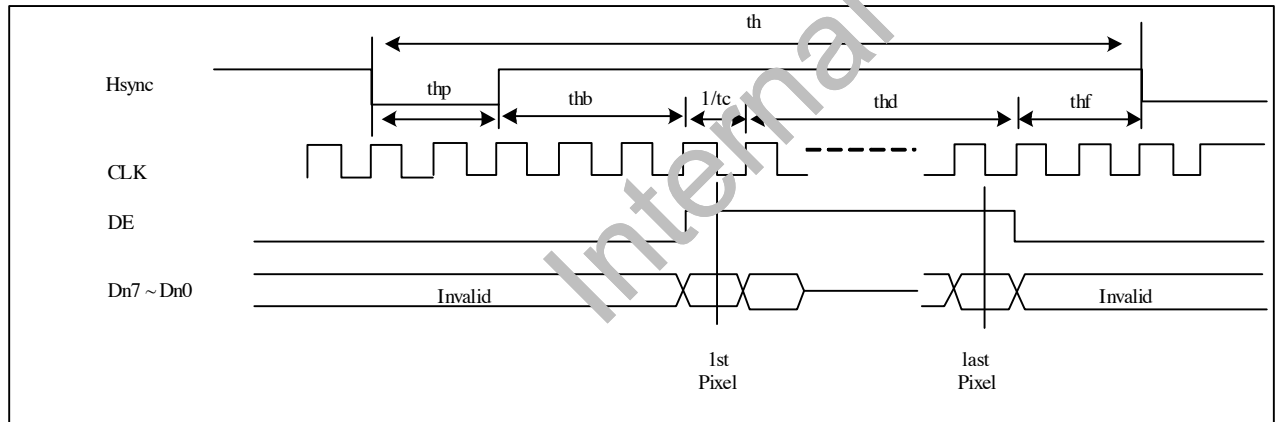

b. Timing Condition

3.4.2.1. Timing Parameters

PARAMETER	Symbol	Min	Typ	Max	Unit
Clock cycle	1/tc	-	9	15	MHz
Hsync cycle	1/fh	-	17.14	-	KHz
Vsync cycle	1/fv	-	59.94	-	Hz
Horizontal Signal					
Horizontal cycle *1	th	-	525	-	CLK
Horizontal display period	thd	-	480	-	CLK
Horizontal front porch *2	thf	2	-	-	CLK
Horizontal pulse width *2	thp	2	41	-	CLK
Horizontal back porch *2	thb	2	2	-	CLK
Vertical Signal					
Vertical cycle	tv	-	286	-	H
Vertical display period	tvd	-	272	-	H
Vertical front porch	tvf	2	2	-	H
Vertical pulse width	tvp	2	10	-	H
Vertical back porch	tvb	2	2	-	H

1. *1. $thd=480CLK$, $thf=2CLK$, $thp=41CLK$, $thb=2CLK$
 $525CLK=480CLK + 2CLK + 41CLK + 2CLK$

2. *2. $thf + fhp + ftb > 44$

5. Power On/Off Sequence

The LCD adopts high voltage driver IC, so it could be permanently damaged under a wrong power on/off sequence. The suggested LCD power sequence is below:

TBD

D. Optical specification

Item	Symbol	Condition	Min.	Typ.	Max.	Unit	Remark
Response Time	Rise	$\theta = 0^\circ$	-	15	-	ms	Note 4
	Fall		Tf	-	25	-	
Contrast ratio	CR	At optimized viewing angle	-	300	-		Note 6, 7
Viewing Angle	Top	$CR \geq 10$	-	40	-	deg.	Note 8
	Bottom		-	60	-		
	Left		-	60	-		
	Right		-	60	-		
Brightness	Y_L	$\theta = 0^\circ$	250	300	-	cd/m ²	Note 9
White Chromaticity	X	$\theta = 0^\circ$		0.31			
	y	$\theta = 0^\circ$		0.33			

Note 1: Measurement is in the dark room, optical ambient temperature =25°C, and backlight current $I_L=20$ mA

Note 2: To be measured in the dark room.

Note 3: To be measured on the center area of panel with a field angle of 1° by Topcon luminance meter BM-7, after 10 minutes operation.

Note 4: Definition of response time:

The output signals of photo detector are measured when the input signals are changed from “black” to “white”(falling time) and from “white”to “black”(rising time), respectively.

Note 5. From liquid crystal characteristics, response time will become slower and the color of panel will become darker when ambient temperature is below 25°C.

Note 6. Definition of contrast ratio:

Contrast ratio is calculated with the following formula.

$$\text{Contrastratio (CR)} = \frac{\text{Photo detector output when LCD is at "White" state}}{\text{Photo detector output when LCD is at "Black" state}}$$

Note 7. White $V_i = V_{i50} + \overline{-}1.5V$

Black $V_i = V_{i50} \pm 2.0V$

“ \pm ” means that the analog input signal swings in phase with COM signal.

“ $\overline{+}$ ” means that the analog input signal swings out of phase with COM signal.

V_{i50} : The analog input voltage when transmission is 50%

The 100% transmission is defined as the transmission of LCD panel when all the input terminals of module are electrically opened.

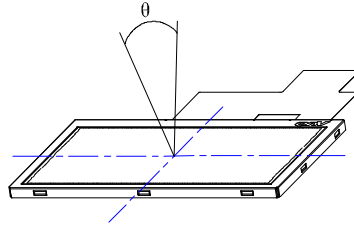

Note 8. Definition of viewing angle: refer to figure as below.

Note 9. Measured at the center area of the panel when all the input terminals of LCD panel are electrically opened.

Internal Use Only

E. Touch Screen Panel Specifications

1. FPC Pin Assignment

Pin No.	Symbol	I/O
1	TP_R	O
2	TP_B	O
3	TP_L	O
4	TP_U	O

2. Electrical Characteristics

Item		Min.	Max.	Unit	Remark
Rate DC Voltage			7	V	
Resistance	X (Film)	550	1300	Ω	At connector
	Y (Glass)	100	700		
Linearity		-1.5%	1.5%	--	Note 1
Response Time			20	ms	
Insulation Resistance		20		MΩ	DC 25V

Note 1: Measurement condition of Linearity: difference between actual voltage & theoretical voltage is an error at any points. Linearity is the value max. error voltage divided by voltage difference on active area.

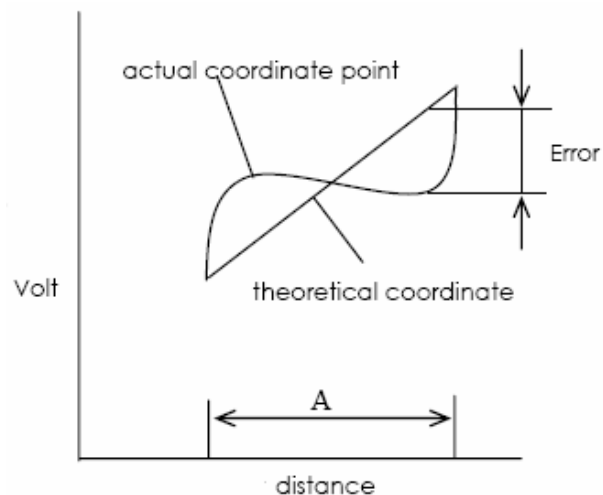

3. Mechanical Characteristics

Item	Min.	Max.	Unit	Remark
Hardness of Surface	3	--	H	JIS K-5400
Operation Force (Pen or Finger)	--	40	gf	Note 1, 2

Note 1: Within "guaranteed active area", but not on the edge and dot-spacer.

Note 2: Measurement condition of Operation Force: Within "guaranteed active area". Resistance, Insulation resistance, and operation force should be under 5.2 & 5.3 condition. When user pushes down on the film, resistance between X & Y axis must be equal or lower than 2kΩ. Below is test figure.

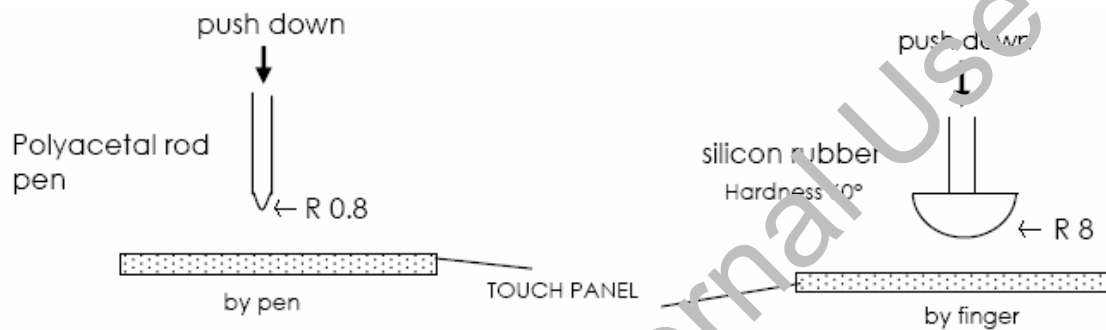

4. Life test Condition

Item	Min.	Max.	Unit	Remark
Notes Life	10 ⁵	--	times	Note 1, 2
Input Life	10 ⁶	--	times	Note 1, 3

Note 2: Notes Life test condition (by pen): Notes area for pen notes life test is 10×9 mm. Size of word is 7.5×6.75mm. Word is any A.B.C..... letter. Writing speed is 60mm/s. Center of each word is changed at random in notes area.

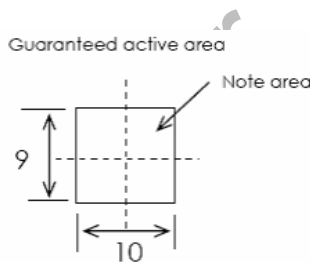

Note 3: Input Life test condition(by finger): By silicone rubber tapping at same point. Tapping Load is 200g, and tapping frequency is 5Hz.

5. Attention

Please pay attention for below matters at mounting design of touch panel of LCD module.

Do not design enclosure pressing the view area to prevent from miss input.

Enclosure support must not touch with view area.

Use elastic or non-conductive material to enclosure touch panel.

Do not bond film of touch panel with enclosure.

The touch panel edge is conductive. Do not touch it with any conductive part after mounting.

If user wants to cleaning touch panel by air gun, pressure $2\text{kg}/\text{cm}^2$ below is suggested. Not to blow glass from FPC site to prevent FPC peeled off.

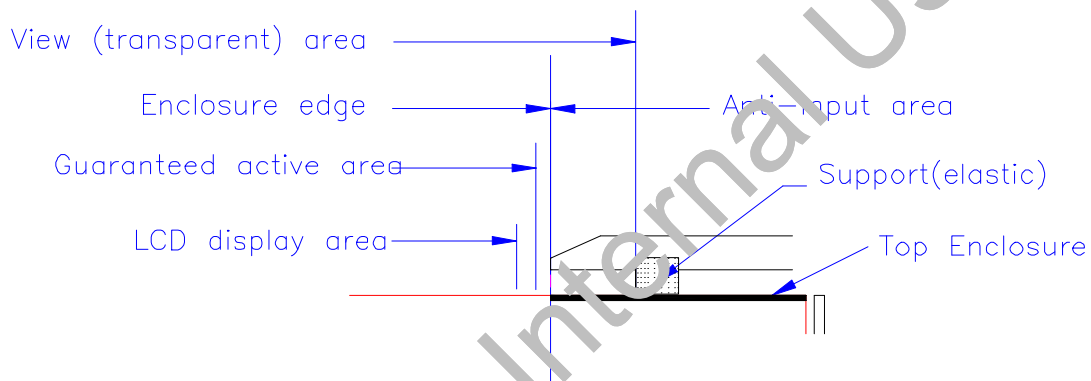

Do not put a heavy shock or stress on touch panel and film surface. Ex. Don't lift the panel by film face with vacuum.

Do not lift LCD module by FPC.

Please use dry cloth or soft cloth with neutral detergent (after wring dry) or one with ethanol at cleaning. Do not use any organic solvent, acid or alkali liquor.

Do not pile touch panel. Do not put heavy goods on touch panel.

F. Reliability test items:

No.	Test items	Conditions	Remark
1	High Temperature Storage	TBD 240Hrs	
2	Low Temperature Storage	TBD 240Hrs	
3	High Temperature Operation	TBD 240Hrs	
4	Low Temperature Operation	TBD 240Hrs	
5	High Temperature & High Humidity	TBD 240Hrs	Operation
6	Heat Shock	TBD	Non-operation
7	Electrostatic Discharge	TBD	Non-operation
8	Vibration	Frequency range TBD Stoke TBD Sweep TBD TBD	Non-operation JIS C7021, A-10 condition A
9	Mechanical Shock	100G . 6ms, ±X,±Y,±Z 3 times for each direction	Non-operation JIS C7021, A-7 condition C
10	Vibration (With Carton)	Random vibration: 0.015G ² /Hz from 5~200Hz -6dB/Octave from 200~500Hz	IEC 68-34
11	Drop (With Carton)	Height: 60cm 1 corner, 3 edges, 6 surfaces	

Note 1: Ta: Ambient Temperature.

Note 2: Squarely inspect all LCD function before and after ambient environment test.

Note3: In the standard conditions, there is not display function NG issue occurred. All the cosmetic specification is judged before the reliability stress.

G. Packing Form
TBD

Internal Use Only

H. Outline Drawing:

