



## CUSTOMER APPROVAL SHEET

<b>Company Name</b>	
<b>MODEL</b>	A061VW01 V0
<b>CUSTOMER APPROVED</b>	Title : Name :

- APPROVAL FOR SPECIFICATIONS ONLY (Spec. Ver.\_\_\_\_)
- APPROVAL FOR SPECIFICATIONS AND ES SAMPLE (Spec. Ver.\_\_\_\_)
- APPROVAL FOR SPECIFICATIONS AND CS SAMPLE (Spec. Ver.\_\_\_\_)
- CUSTOMER REMARK :

AUO PM :

P/N : \_\_\_\_\_

Comment :

1 Li-Hsin Rd. 2. Science-Based Industrial Park  
Hsinchu 300, Taiwan, R.O.C.  
Tel: +886-3-500-8899  
Fax: +886-3-577-2730



Doc. version :	0.0
Total pages :	24
Date :	2009/08/06

# Product Specification

## 6.1" COLOR TFT-LCD MODULE

**Model Name :** A061VW01 V0

---

**Planned Lifetime:** From 2009/Sep To 2010/Dec  
**Phase-out Control:** From 2010/July To 2010/Dec  
**EOL Schedule:** 2010/Dec

---

<  > Preliminary Specification

<  > Final Specification

Note: The content of this specification is subject to change.

© 2009 AU Optronics  
All Rights Reserved,  
Do Not Copy.



Record of Revision

Version	Revise Date	Page	Content
0.0	2009/08/06	All	First Draft.

## Contents

<b>A. General Information</b>	<b>3</b>
<b>B. Outline Dimension</b>	<b>4</b>
1. TFT-LCD Module – Front View	4
2. TFT-LCD Module – Rear View	5
<b>C. Electrical Specifications</b>	<b>6</b>
1. TFT LCD Panel Pin Assignment	6
2. Backlight Pin Assignment	8
3. Absolute Maximum Ratings	8
4. Electrical DC Characteristics	9
5. Electrical AC Characteristics	11
6. Power On/Off Characteristics	14
<b>D. Optical Specification</b>	<b>15</b>
<b>E. Reliability Test Items</b>	<b>18</b>
<b>F. Packing and Marking</b>	<b>21</b>
1. Packing Form	21
2. Module/Panel Label Information	22
3. Carton Label Information	22
<b>G. Application Note</b>	<b>23</b>
1. Application Circuit	23
<b>H. Precautions</b>	<b>24</b>

### A. General Information

This product is for Car application.

NO.	Item	Unit	Specification	Remark
1	Screen Size	inch	6.1(Diagonal)	
2	Display Resolution	dot	800RGB(W)x480(H)	
3	Overall Dimension	mm	149(W)x82.9(H)x5.1(D)	Note 1
4	Active Area	mm	136.2(W)x72(H)	
5	Pixel Pitch	mm	0.17025(W)x0.15(H)	
6	Color Configuration	--	R. G. B. Stripe	Note 2
7	Color Depth	--	262K Colors	Note 3
8	NTSC Ratio	%	50	
9	Display Mode	--	Normally White	
10	Panel surface Treatment	--	Anti-Glare, 3H	
11	Weight	g	120 ±10	
12	Panel Power Consumption	mW	TBD	Note 4
13	Backlight Power Consumption	W	1.536	
	Viewing direction		6 o'clock (gray inversion)	

Note 1: Not include backlight cable and FPC. Refer next page to get further information.

Note 2: Below figure shows dot stripe arrangement.

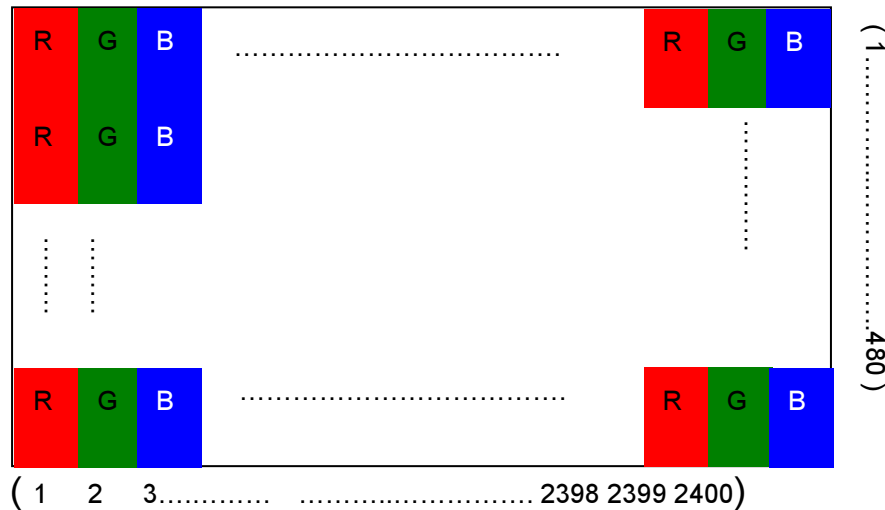

Note 3: The full color display depends on 18-bit data signal (Pin 7~18, Pin 32~37).

Note 4: Please refer to Electrical Characteristics chapter.

**B. Outline Dimension**  
**1. TFT-LCD Module – Front View**

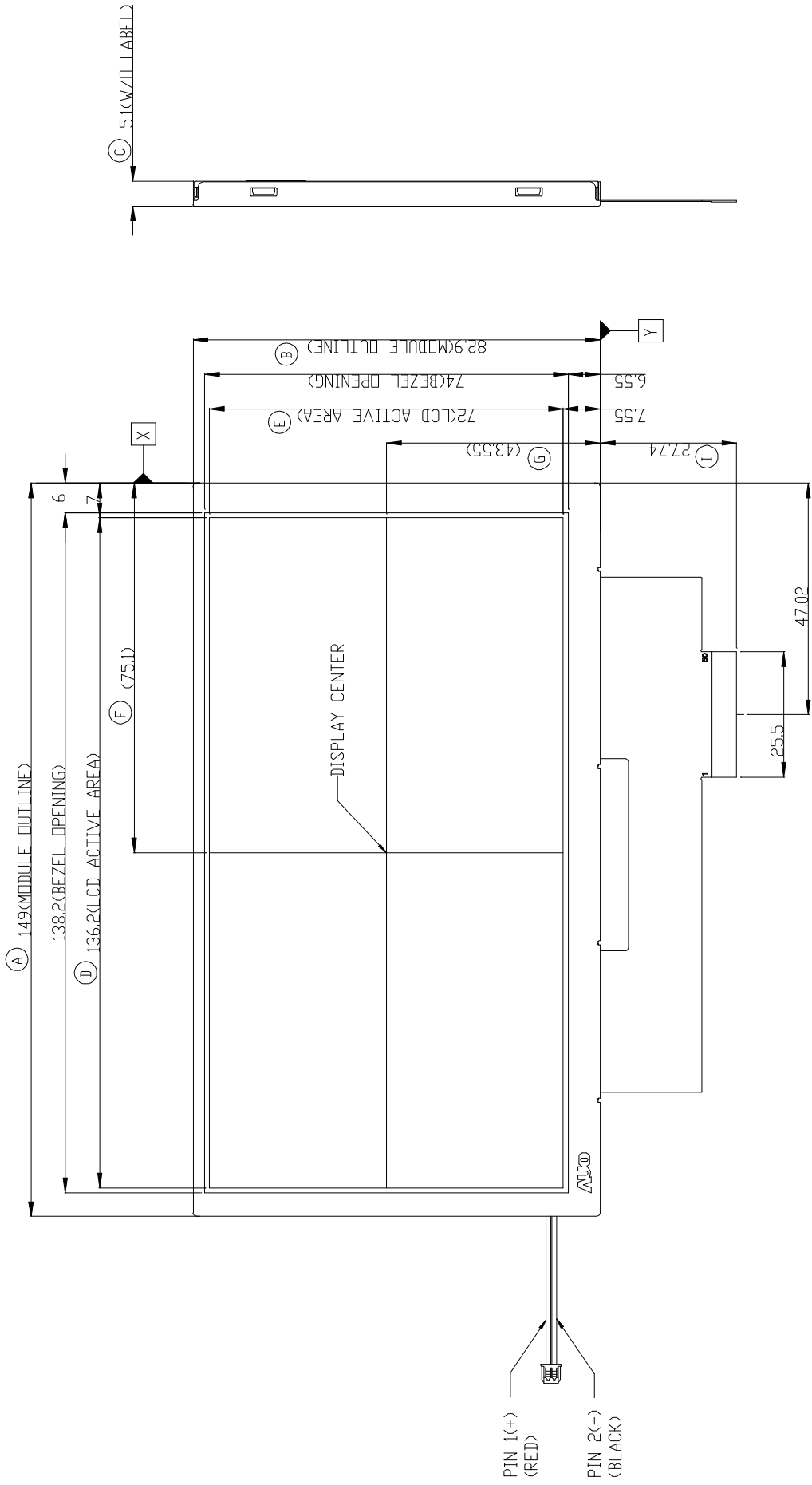

## 2. TFT-LCD Module – Rear View

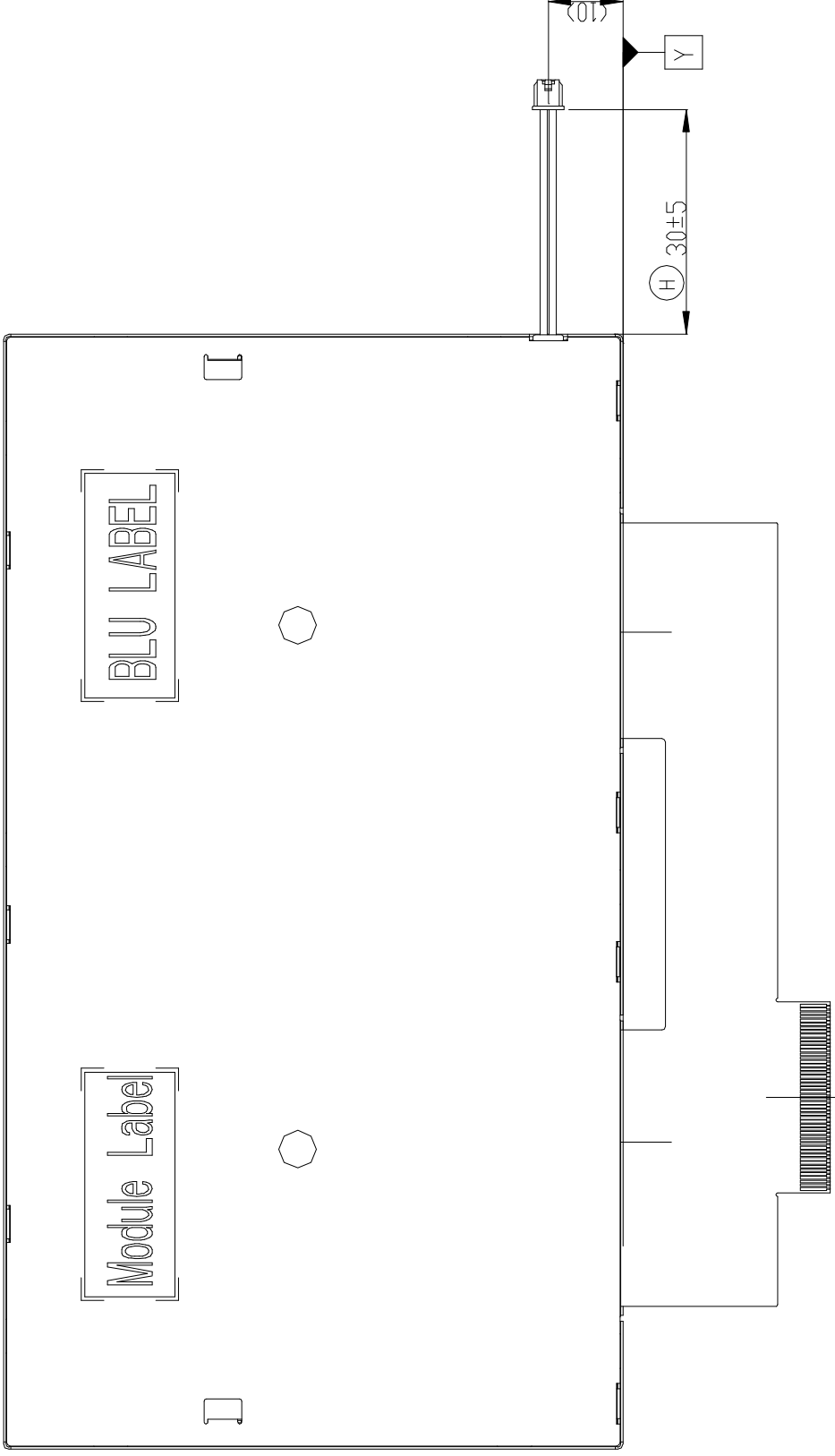

## C. Electrical Specifications

### 1. TFT LCD Panel Pin Assignment

Recommended connector : Hirose FH12-50S-0.5SH

NO.	Symbol	I/O	Description	Remark
1	VCOM	I	Common electrode driving voltage	
2	STHL	I/O	Horizontal start pulse	NOTE 1
3	GND	P	Ground	
4	DCLK	I	Data clock Input	
5	GND	P	Ground	
6	L/R	I	Left/Right selection	NOTE 1
7	DR0	I	Red data Input (LSB )	
8	DR1	I	Red data Input	
9	DR2	I	Red data Input	
10	DR3	I	Red data Input	
11	DR4	I	Red data Input	
12	DR5	I	Red data Input ( MSB )	
13	DG0	I	Green data Input (LSB)	
14	DG1	I	Green data Input	
15	DG2	I	Green data Input	
16	DG3	I	Green data Input	
17	DG4	I	Green data Input	
18	DG5	I	Green data Input (MSB)	
19	GND	P	Ground	
20	AVDD	P	Analog power supply voltage	
21	AVDD	P	Analog power supply voltage	
22	V1	I	Gamma correction voltage reference	
23	V2	I	Gamma correction voltage reference	
24	V3	I	Gamma correction voltage reference	
25	V4	I	Gamma correction voltage reference	
26	V5	I	Gamma correction voltage reference	
27	V6	I	Gamma correction voltage reference	
28	V7	I	Gamma correction voltage reference	
29	V8	I	Gamma correction voltage reference	
30	V9	I	Gamma correction voltage reference	
31	V10	I	Gamma correction voltage reference	
32	DB0	I	Blue data Input (LSB)	
33	DB1	I	Blue data Input	



34	DB2	I	Blue data Input	
35	DB3	I	Blue data Input	
36	DB4	I	Blue data Input	
37	DB5	I	Blue data Input (MSB)	
38	GND	P	Ground	
39	VDDIO	P	Digital interface supply voltage of digital	
40	VDDIO	P	Digital interface supply voltage of digital	
41	LD	I	Load Data output signal	NOTE 2
42	POL	I	Polarity selection of Data output	NOTE 3
43	STHR	I/O	Horizontal start pulse	NOTE 1
44	OEV	I	Gate outputs enable, active LOW.	
45	U/D	I	Up/Down selection.	NOTE 1
46	CKV	I	Vertical clock	
47	STVU	I/O	Vertical start pulse	NOTE 1
48	STVD	I/O	Vertical start pulse	NOTE 1
49	VGH	P	Positive power supply voltage for Gate driver	
50	VGL	P	Negative power supply voltage for Gate driver	

I: Input pin; P: Power pin; I/O: Input/Output pin

Note 1.

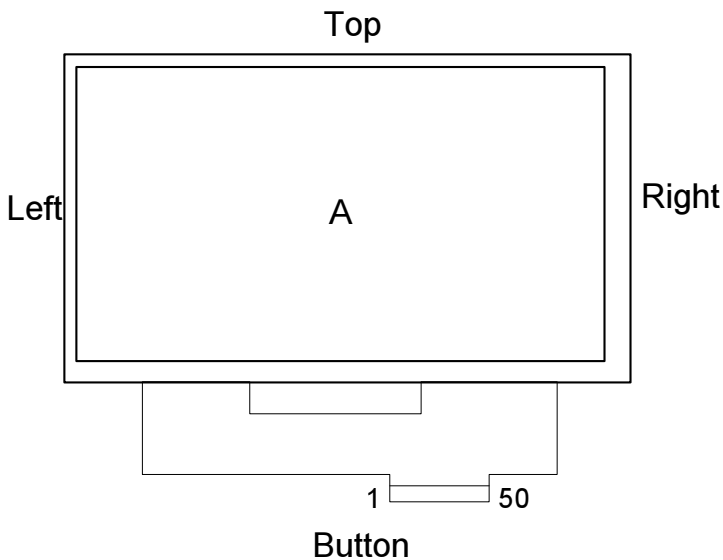

U/D	STVU	STUD	Direction
H	Output	Input	Button -> Top
L	Input	Output	Top -> Button

L/R	STHL	STHR	Direction
H	Input	Output	Left->Right
L	Output	Input	Right->Left

**Note 2. LD**

Latches the polarity of outputs and switches the new data to outputs.

1. At the rising edge, latches the “POL” signal to control the polarity of the outputs.
2. The pin also controls the switch of the line registers that switches the new incoming data to outputs.

**Note 3. POL**

“POL” value is latched at the rising edge of “LD” to control the polarity of the even or odd outputs

1. Positive polarity : output voltage range from V1 to V5.
2. Negative polarity : output voltage range from V6 to V10.
3. POL=1: Even outputs range from V1 ~ V5, and Odd outputs range from V6 ~ V10
4. POL=0 : Even outputs range from V6 ~ V10, and Odd outputs range from V1 ~ V5

## 2. Backlight Pin Assignment

Recommended connector : H201K-P020N-02B

Pin no	Symbol	I/O	Description	Remark
1	HI	I	Power supply for backlight unit (High voltage)	
2	GND	-	Ground for backlight unit	

## 3. Absolute Maximum Ratings

Item	Symbol	Condition	Min.	Max.	Unit	Remark
Power voltage	VDDIO	GND=0	-0.5	5	V	
	AVDD	GND=0	-0.5	13.5	V	
	VGH	GND=0	-0.3	40	V	
	VGL		-20	0.3	V	
	VGH – VGL		-	40	V	
Input signal voltage	VI	GND=0	-0.3	VDDIO+0.3	V	Note 1
	VCOM		0	6.7	V	
Operating temperature	Topa		-10	60	□	
Storage temperature	Tstg		-20	70	□	

Note 1: Digital Data.

Note 2: Functional operation should be restricted under ambient temperature (25□).

Note 3: Maximum ratings are those values beyond which damages to the device may occur. Functional operation should be restricted to the limits in the Electrical Characteristics chapter.

#### 4. Electrical DC Characteristics

##### a. (VDDIO = +3.3V, AVDD=TBDV, GND=0V)

Item		Symbol	Min.	Typ.	Max.	Unit	Remark
Power supply		VDDIO	3.0	3.3	3.6	V	Note3
		IVDDIO	--	TBD	TBD	mA	
		AVDD	TBD	TBD	TBD	V	Note3
		IAVDD	--	TBD	TBD	mA	
		VGH	TBD	TBD	TBD	V	Note3
		IVGH	--	TBD	TBD	mA	
		VGL	TBD	TBD	TBD	V	Note3
		IVGL	--	TBD	TBD	mA	
		Vcom	TBD	TBD	TBD	V	
Input signal	H Level	Vih	0.7×VDDIO	-	VDDIO	V	Note 1
	L Level	ViL	0	-	0.3×VDDIO	V	
Input Voltage Reference		V1~V5	0.4*AVDD	-	AVDD-0.5	V	Note 2
		V6~V10	0.5	-	0.6*AVDD	V	Note 2

Note 1 : Digital Data

Note 2 : GND <V10<V9V<V8<V7<V6<V5<V4<V3<V2<V1<AVDD

Note 3 : Typical current test pattern

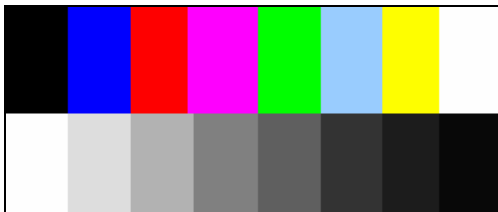

**b. Gamma voltage suggested circuit is as follows**

TBD

**c. Vcom suggested circuit is as follows**

TBD

**d. Backlight Driving Conditions**

Parameter	Symbol	Min.	Typ.	Max.	Unit	Remark
LED Lightbar current	$I_L$	-	160	-	mA	Note 1, 2
Power consumption	P	-	1.536	-	W	
LED Lightbar life time		10,000	-	-	Hr	Note 1, 2, 3, 4

Note 1: LED backlight is LED lightbar type(24 pcs of LED).

Note 2: Definition of “LED Lifetime”: brightness is decreased to 50% of the initial value. LED Lifetime is restricted under normal condition, ambient temperature = 25°C and LED lightbar current= 160mA

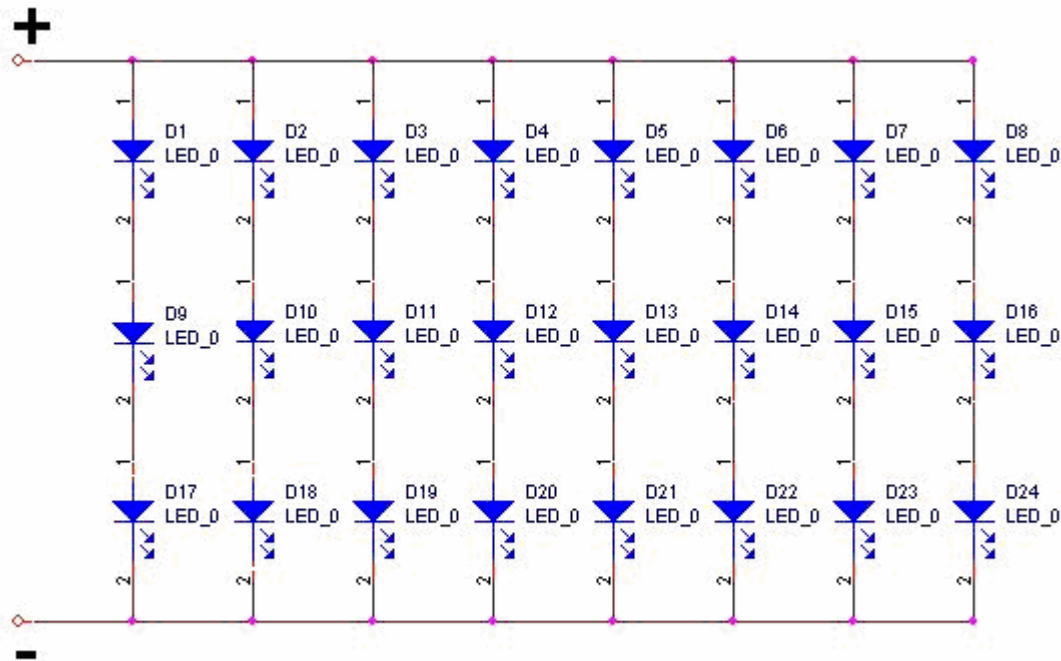

Note 3: The value is only for reference.

Note 4: If it operates with LED lightbar current more than 160mA, it maybe decreases LED lifetime.

## 5. Electrical AC Characteristics

### a. Signal AC Characteristics

Vertical timing:

Parameter	Symbol	Min.	Typ.	Max.	Unit.	Remark
STVD/STVU Delay Time	Tdt	--	--	500	ns	
Driver Output Delay Time	Tdo	--	--	900	ns	
Output Falling Time	Tthl	--	400	800	ns	
Output Rise Time	Tthh	--	500	1000	ns	
OE to Driver Output Delay Time	Toe	--	--	900	ns	
Clock Rise Time	Trck	--	--	100	ns	
Clock Falling Time	Tfck	--	--	100	ns	
Clock Pulse Width(High period or Low period)	PWCLK	500	--	--	ns	
STVD/STVU Set-up Time	Tsu	200	--	--	ns	
STVD/STVU Hold Time	Thd	300	--	--	ns	
Output Enabled pulse width	Twcl	1	--	--	us	

Horizontal timing:

Parameter	Symbol	Min.	Typ.	Max.	Unit.	Remark
CLK Frequency	Fclk	--	50	55	MHz	
CLK pulse width	Tcw	40%	--	60%	Tcph	
Data Setup Time	Tsu	4			ns	Note 1
Data Hold Time	Thd	2	--	--	ns	
Propagation delay of STHL /STHR	Tphl	6	10	15	ns	
Time that the last data to LD	Tld	1	--	--	Tcph	
Pulse width of LD	Twld	2	--	--	Tcph	
Time that LD to STHL/STHR	Tlds	5	--	--	Tcph	
POL set-up time	Tpsu	6	--	--	ns	POL to LD
POL hold time	Tphd	6	--	--	ns	POL to LD
Output stable time	Tst	--	--	9	us	

Note 1 : Input Data , STVL and STVR

### b. Input Timing Waveform

Vertical Timing waveform

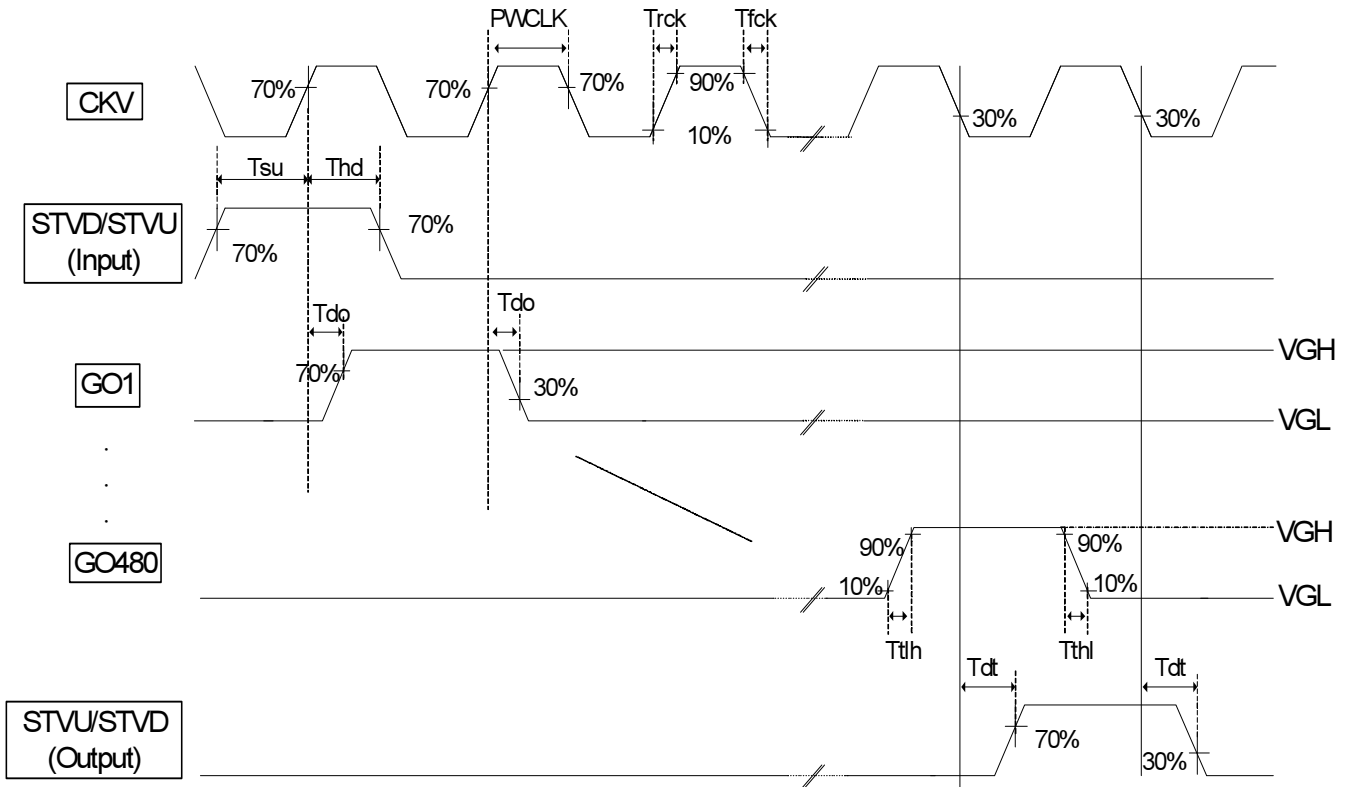

Horizontal Timing waveform

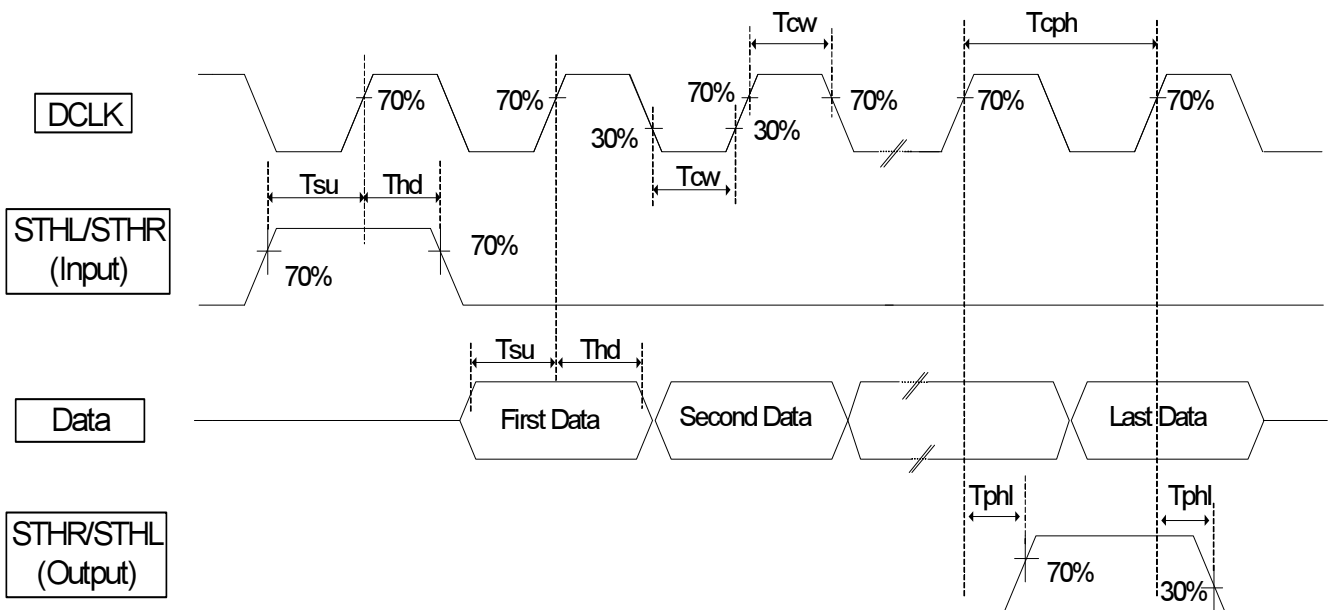

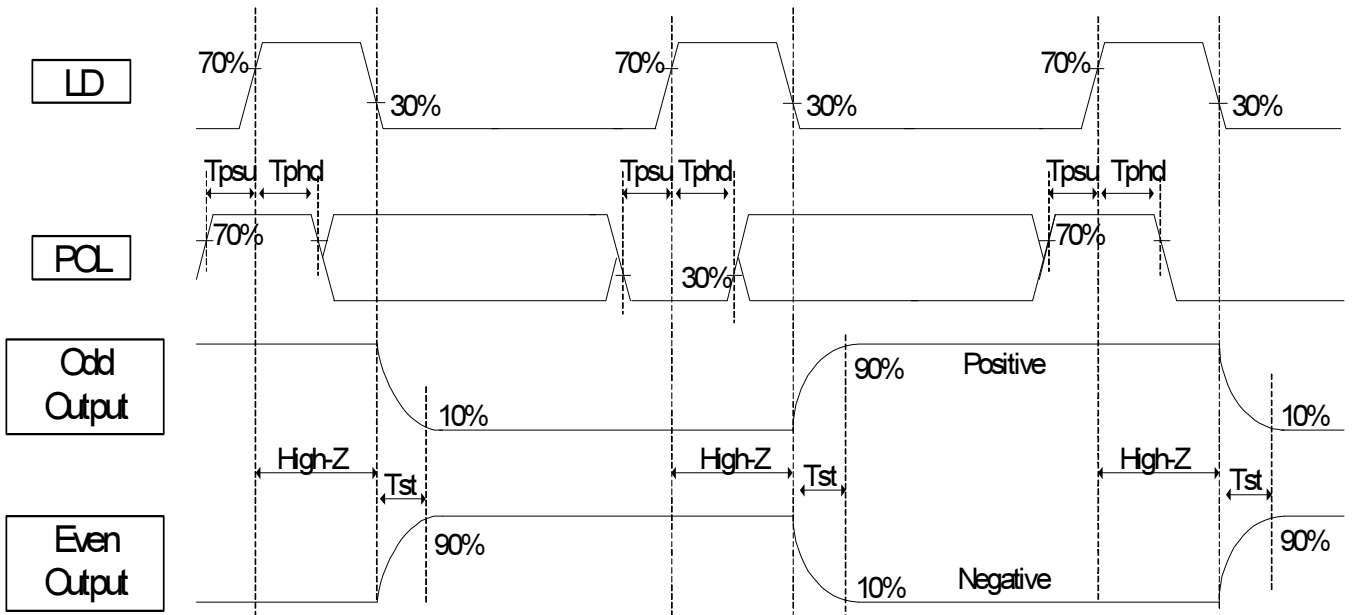
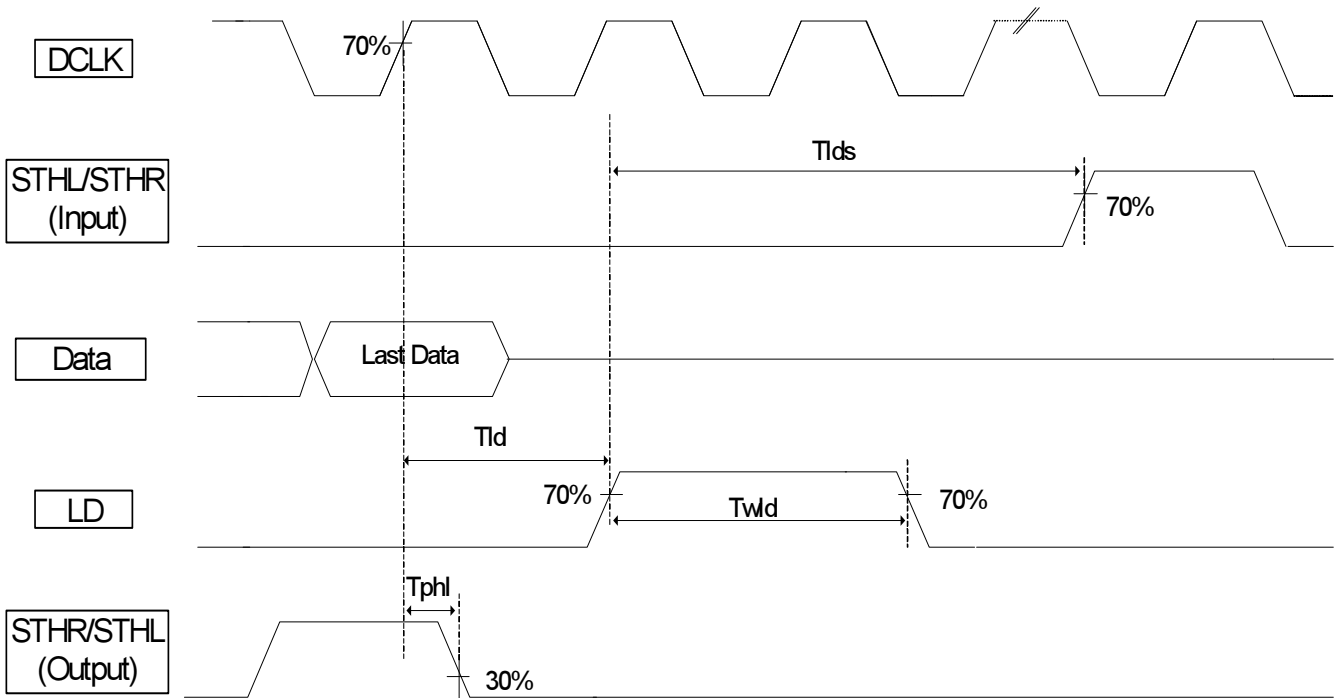

### 6. Power On/Off Characteristics

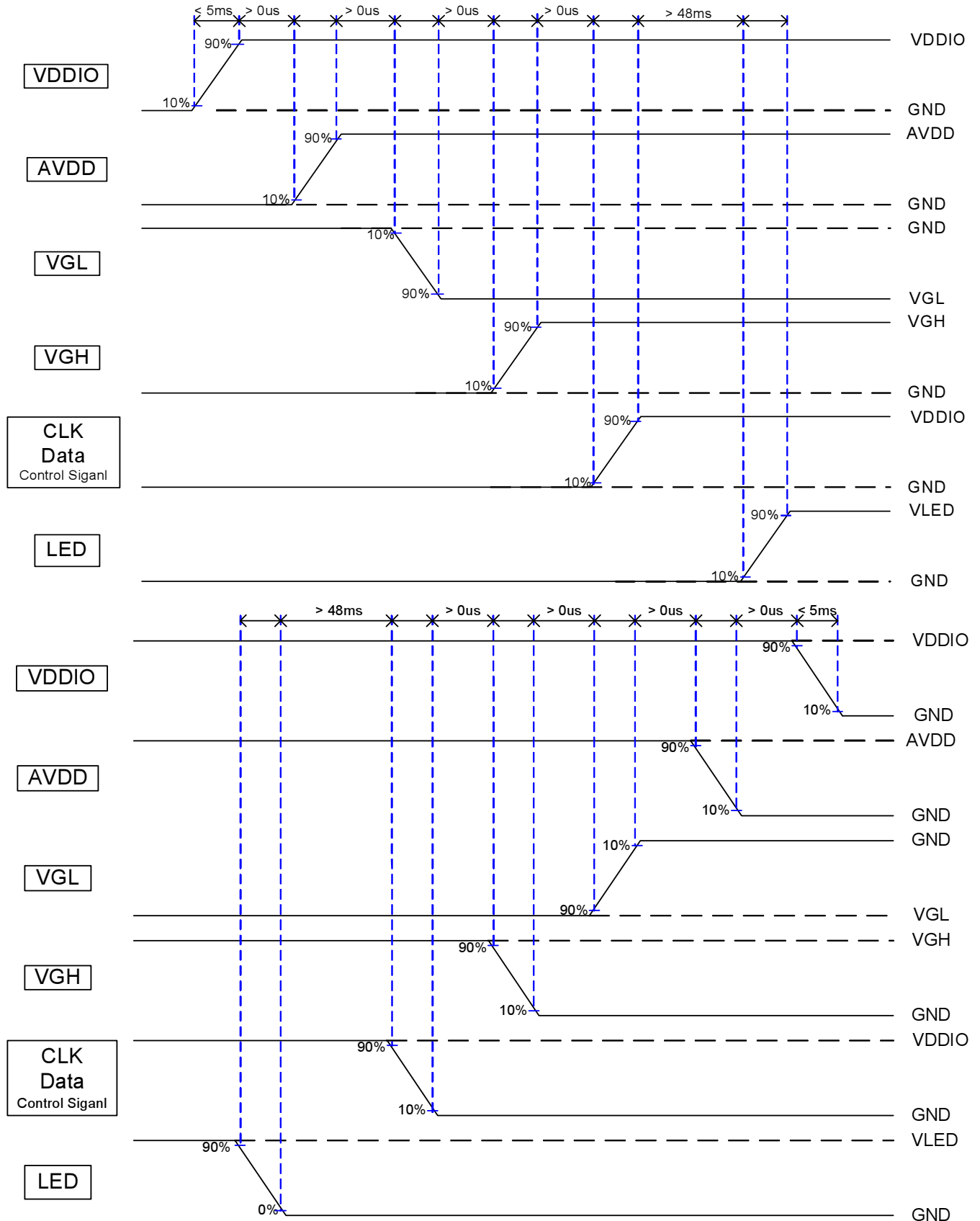



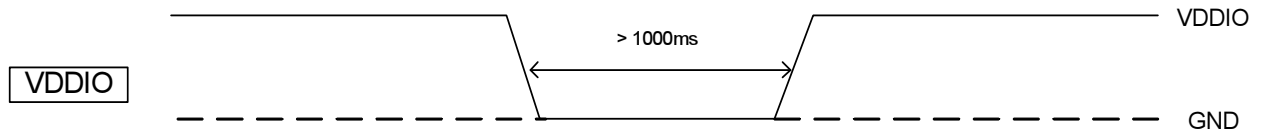

## D. Optical Specification

All optical specification is measured under typical condition (Note 1, 2)

Item	Symbol	Condition	Min.	Typ.	Max.	Unit	Remark
Response Time							
Rise	$T_r$	$\theta=0^\circ$	--	12	24	ms	Note 3
Fall	$T_f$	$\theta=0^\circ$	--	18	36	ms	
Contrast ratio	CR	At optimized viewing angle	400	500	--		Note 4
Viewing Angle		$CR \geq 10$				deg.	Note 5
Top			35	45			
Bottom			55	65			
Left			55	65			
Right			55	65			
Brightness	$Y_L$	$\theta=0^\circ$	350	430	--	$cd/m^2$	Note 6
Chromaticity	White	X	$\theta=0^\circ$	0.25	0.30	0.35	
		Y	$\theta=0^\circ$	0.27	0.32	0.37	
	Red	X	$\theta=0^\circ$		TBD		
		Y	$\theta=0^\circ$		TBD		
	Green	X	$\theta=0^\circ$		TBD		
		Y	$\theta=0^\circ$		TBD		
	Blue	X	$\theta=0^\circ$		TBD		
		Y	$\theta=0^\circ$		TBD		
Uniformity	$\Delta Y_L$	%	70	75	--	%	Note 7

Note 1: Ambient temperature =25 $\square$ , and LED lightbar currently  $I_L = 160mA$ . To be measured in the dark room.

Note 2: To be measured on the center area of panel with a viewing cone of 1 $^\circ$  by Topcon luminance meter BM-5A, after 15 minutes operation.

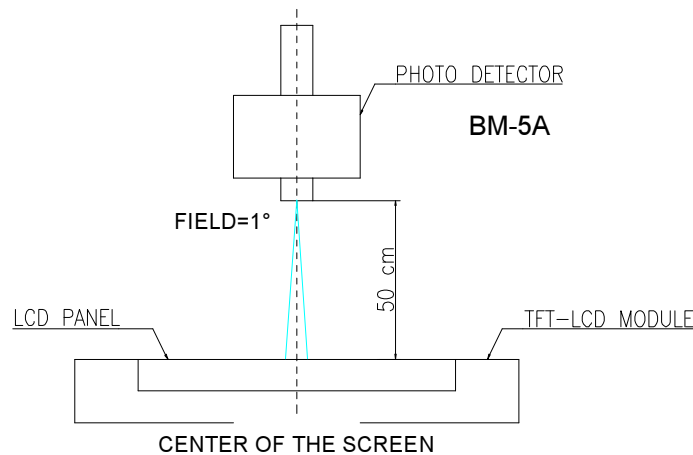

**Note 3: Definition of response time:**

The output signals of photo detector are measured when the input signals are changed from "black" to "white"(falling time) and from "white" to "black"(rising time), respectively.  
The response time is defined as the time interval between the 10% and 90% of amplitudes.  
Refer to figure as below.

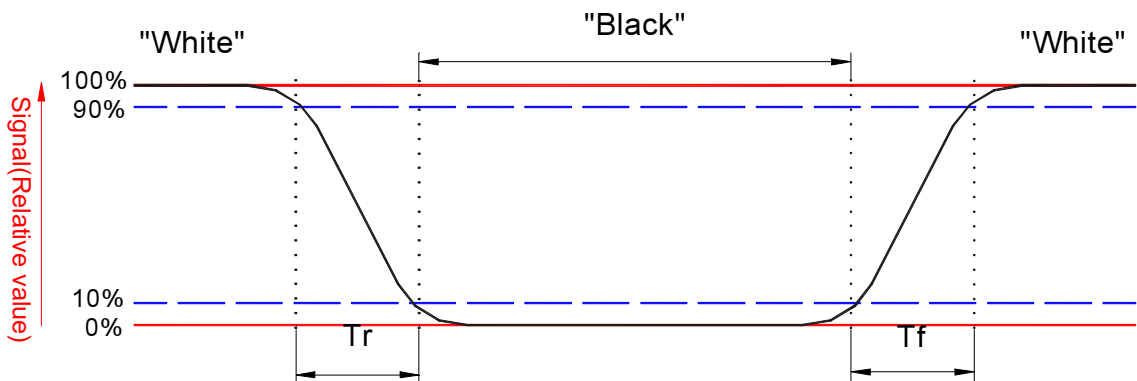

**Note 4. Definition of contrast ratio:**

Contrast ratio is calculated with the following formula.

$$\text{Contrast ratio (CR)} = \frac{\text{Photo detector output when LCD is at "White" status}}{\text{Photo detector output when LCD is at "Black" status}}$$

**Note 5. Definition of viewing angle,  $\theta$ , Refer to figure as below.**

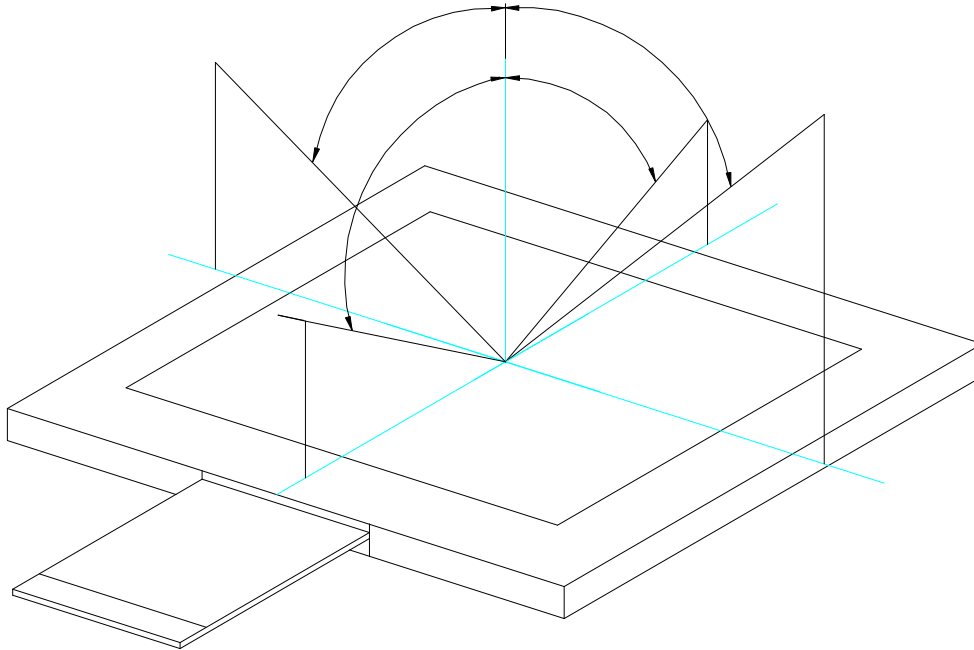

Note 6. Measured at the center area of the panel when all the input terminals of LCD panel are electrically opened.

Note 7: Luminance Uniformity of these 9 points is defined as below:

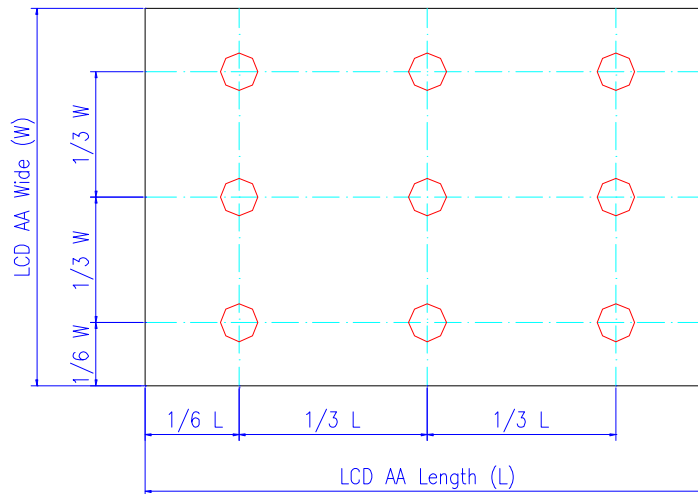

$$\text{Uniformity} = \frac{\text{minimum luminance in 9 points (1-9)}}{\text{maximum luminance in 9 points (1-9)}}$$

## E. Reliability Test Items

No.	Test items	Conditions	Remark
1	High Temperature Storage	Ta= 80□ 240Hrs	
2	Low Temperature Storage	Ta= -30□ 240Hrs	
3	High Ttemperature Operation	Tp= 70□ 240Hrs	
4	Low Temperature Operation	Ta= -20□ 240Hrs	
5	High Temperature & High Humidity	Tp= 50□. 80% RH 240Hrs	Operation
6	Heat Shock	-20□~70□/50 cycles 2Hrs/cycle	Non-operation
7	Electrostatic Discharge	Contact = ± 4 kV, class B Air = ± 8 kV, class B	Note 4
8	Image Sticking	25□, 4hrs	Note 5
9	Vibration	Frequency range : 10~55Hz Stoke : 1.5mm Sweep : 10 ~ 55 ~ 10Hz 2 hours for each direction of X,Y,Z (6 hours for total)	Non-operation JIS C7021, A-10 condition A : 15 minutes
10	Mechanical Shock	100G . 6ms, ±X,±Y,±Z 3 times for each direction	Non-operation JIS C7021, A-7 condition C
11	Vibration (With Carton)	Random vibration: 0.015G <sup>2</sup> /Hz from 5~200Hz -6dB/Octave from 200~500Hz	IEC 68-34
12	Drop (With Carton)	Height: 60cm 1 corner, 3 edges, 6 surfaces	
13	Pressure	5kg, 5sec	Note 6

Note 1: Ta: Ambient Temperature. Tp: Panel Surface Temperature

Note 2: In the standard conditions, there is not display function NG issue occurred. All the cosmetic specification is judged before the reliability stress.

Note 3: All the cosmetic specification is judged before the reliability stress.

Note4 : All test techniques follow IEC6100-4-2 standard.

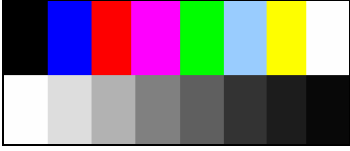
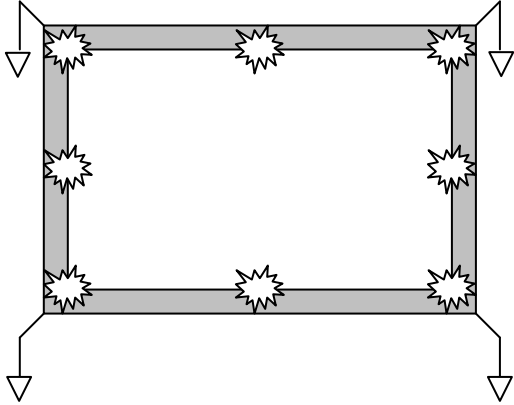
Test Condition		Note
<p><b>Pattern</b></p>		
<p><b>Procedure And Set-up</b></p>	<p><u>Contact Discharge</u> : 330Ω, 150pF, 1sec, 8 point, 25times/point  <u>Air Discharge</u> : 330Ω, 150pF, 1sec, 8 point, 25times/point</p> 	
<p><b>Criteria</b></p>	<p>B – Some performance degradation allowed. No data lost.            Self-recoverable hardware failure.</p>	
<p><b>Others</b></p>	<p>1. Gun to Panel Distance</p>	

Note 5: Operate with 5×5 chess board pattern as figure and lasting time and temperature as the conditions. Then judge with 50% gray level after waiting 20 min, the mura is less than JND 2.5.

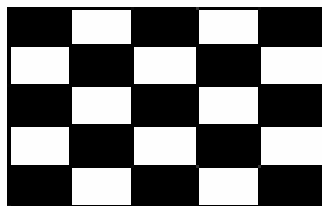

Note 6: The panel is tested as figure. The jig is ϕ10 mm made by Cu with rubber and the loading speed is 3mm/min on position A~E. After the condition, no glass crack will be found and panel function check is OK.(no guarantee LC mura、LC bubble)

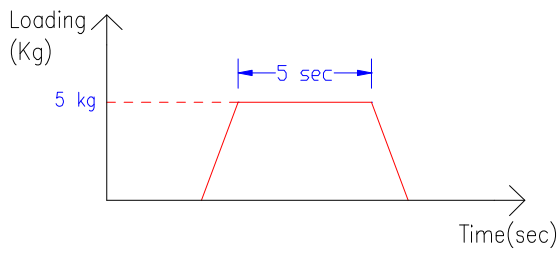
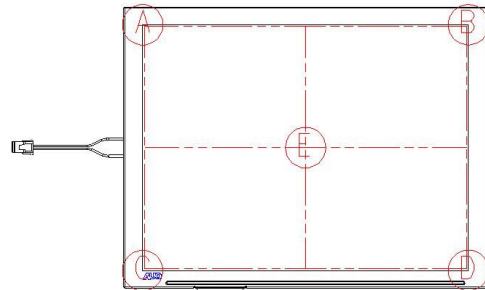
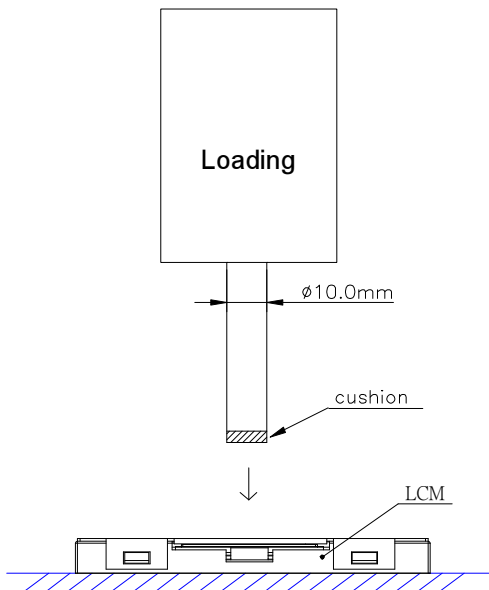

## F. Packing and Marking

### 1. Packing Form

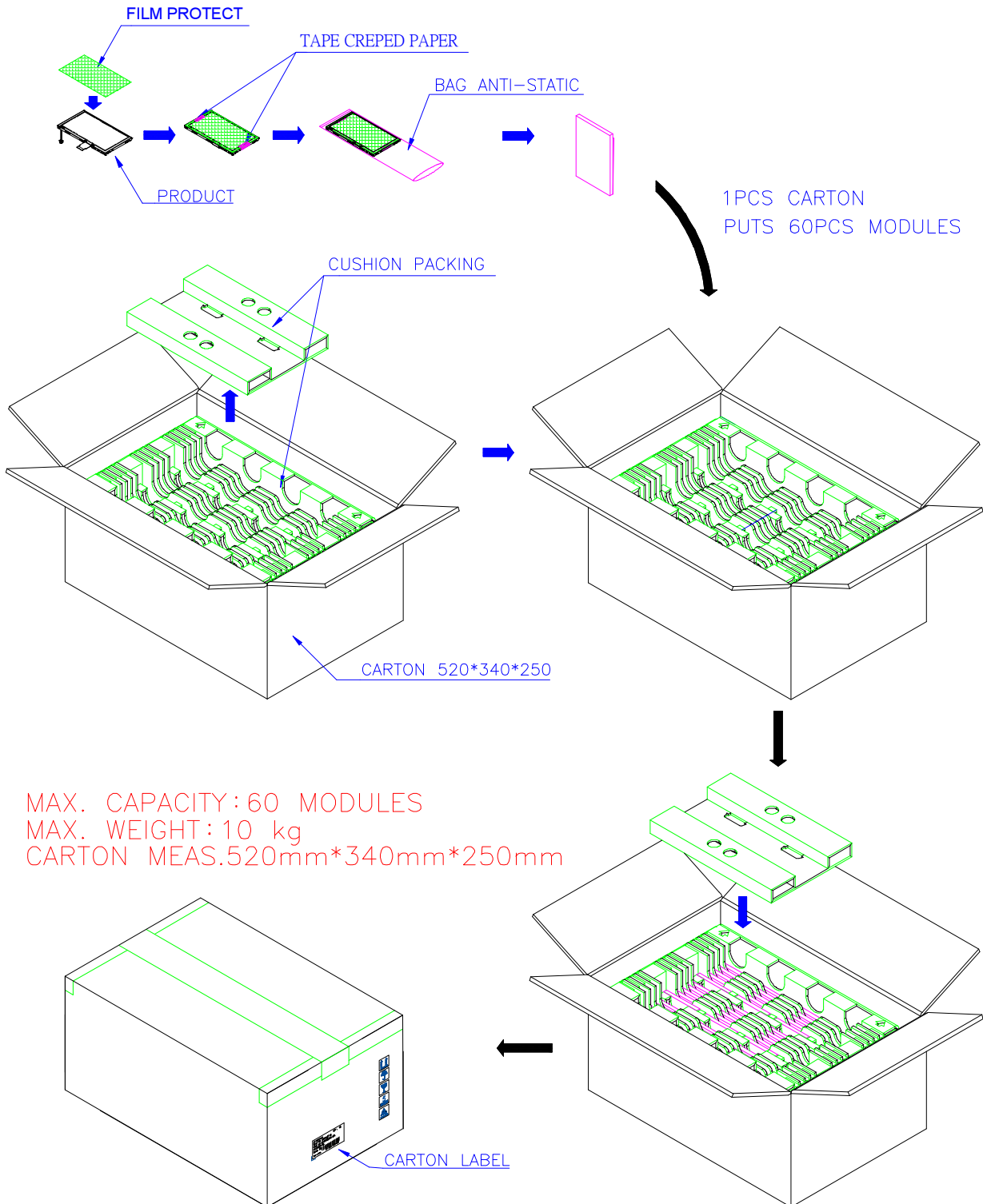

## 2. Module/Panel Label Information

The module/panel (collectively called as the "Product") will be attached with a label of Shipping Number which represents the identification of the Product at a specific location. Refer to the Product outline drawing for detailed location and size of the label. The label is composed of a 22-digit serial number and printed with code 39/128 with the following definition:

ABCDEFGHIJKLMNOPQRSTUV

- └─ For internal system usage and production serial numbers.
- └─ AUO Module or Panel factory code, represents the final production factory to complete the Product
- └─ Product version code, ranging from 0~9 or A~Z (for Version after 9)
- └─ Week Code, the production week when the product is finished at its production process

## 3. Carton Label Information

The packing carton will be attached with a carton label where packing Q'ty, AUO Model Name, AUO Part Number, Customer Part Number (Optional) and a series of Carton Number in 13 or 14 digits are printed. The Carton Number is appearing in the following format:

ABC-DEFG-HIJK-LMN

- └─ DEFG appear after first "-" represents the packing date of the carton
- └─ Date from 01 to 31
- └─ Month, ranging from 1~9, A~C. A for Oct, B for Nov and C for Dec.
- └─ A.D. year, ranging from 1~9 and 0. The single digit code represents the last number of the year

Refer to the drawing of packing format for the location and size of the carton label.



## G. Application Note

### 1. Application Circuit

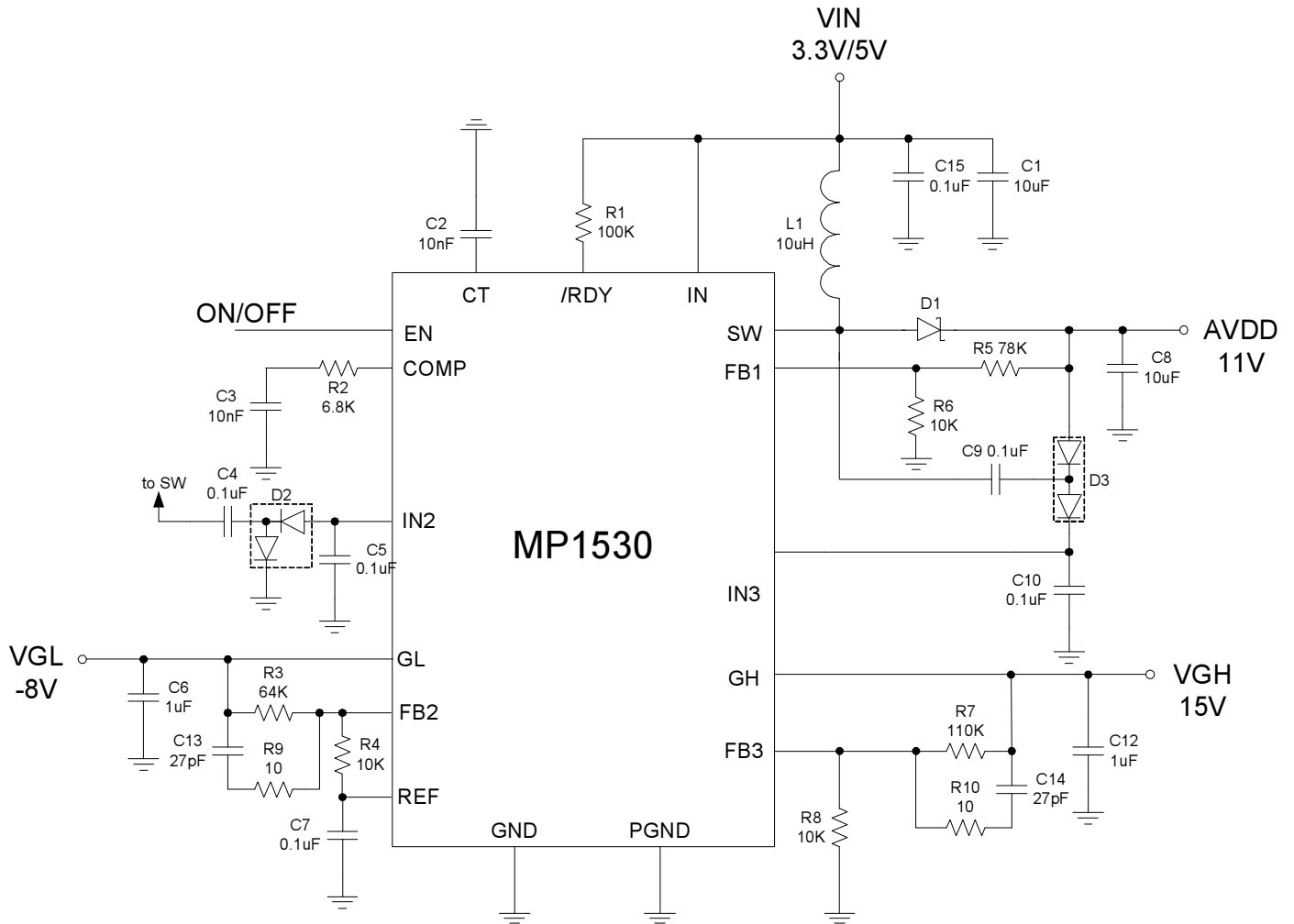

## H. Precautions

1. Do not twist or bend the module and prevent the unsuitable external force for display module during assembly.
2. Adopt measures for good heat radiation. Be sure to use the module with in the specified temperature.
3. Avoid dust or oil mist during assembly.
4. Follow the correct power sequence while operating. Do not apply the invalid signal, otherwise, it will cause improper shut down and damage the module.
5. Less EMI: it will be more safety and less noise.
6. Please operate module in suitable temperature. The response time & brightness will drift by different temperature.
7. Avoid to display the fixed pattern (exclude the white pattern) in a long period, otherwise, it will cause image sticking.
8. Be sure to turn off the power when connecting or disconnecting the circuit.
9. Polarizer scratches easily, please handle it carefully.
10. Display surface never likes dirt or stains.
11. A dewdrop may lead to destruction. Please wipe off any moisture before using module.
12. Sudden temperature changes cause condensation, and it will cause polarizer damaged.
13. High temperature and humidity may degrade performance. Please do not expose the module to the direct sunlight and so on.
14. Acetic acid or chlorine compounds are not friends with TFT display module.
15. Static electricity will damage the module, please do not touch the module without any grounded device.
16. Do not disassemble and reassemble the module by self.
17. Be careful do not touch the rear side directly.
18. No strong vibration or shock. It will cause module broken.
19. Storage the modules in suitable environment with regular packing.
20. Be careful of injury from a broken display module.
21. Please avoid the pressure adding to the surface (front or rear side) of modules, because it will cause the display non-uniformity or other function issue.