

Version	2
Total pages	20
Date	2002.11.11

# Product Specification

## 6.5" color TFT-LCD module

MODEL NAME: A065GW01

- ( ◆ ) Preliminary Specification
- ( ..... ) Final Specification

Note: The content of this specification is subject to change.

© 2002 AU Optronics  
All Rights Reserved,  
Do Not Copy.



**Contents:**

**A. Physical specification..... P3**

**B. Electrical specifications..... P4**

    1. Pin assignment..... P4

        a. TFT-LCD panel driving section..... P4

        b. Backlight driving section..... P5

    2. Absolute maximum ratings..... P5

    3. Environment conditions..... P6

    4. Electrical characteristics..... P6

        a. Typical operating conditions..... P6

        b. Current consumption..... P6

        c. Backlight driving conditions..... P6

    5. AC Timing..... P7

        a. Timing conditions..... P7

        b. Timing diagram..... P8

**C. Optical specifications..... P8**

**D. Reliability test items..... P10**

**E. Packing form..... P11**

**Appendix:**

Fig.1 Outline dimension of TFT-LCD module. .... **P12**  
Fig.2 Sampling clock timing. .... **P14**  
Fig.3 Horizontal display timing range. .... **P15**  
Fig.4-(a) Horizontal timing. .... **P16**  
Fig.4- (b) Detail horizontal timing. .... **P17**  
Fig.5 Vertical shift clock timing. .... **P18**  
Fig.6- (a) Vertical timing (From up to down).. .... **P19**  
Fig.6-(b) Vertical timing (From down to up) .... **P20**

**A. Physical specifications**

NO.	Item	Specification	Remark
1	Display resolution(dot)	400RGB(W)×234(H)	
2	Active area(mm)	143.4W)×79.326(H)	
3	Screen size(inch)	6.5(Diagonal)	
4	Dot pitch(mm)	0.119.5(W)×0.339 (H)	
5	Color configuration	R. G. B. stripe	
6	Overall dimension(mm)	157.2(W)×89.8(H) ×7.8(D)	Note 1
7	Weight(g)	155±20	
8	Surface treatment	AG(5.5% haze) & with WV film	
9	Backlight unit	L type lamp	

Note 1: Refer to Fig. 1

## B. Electrical specifications

### 1.Pin assignment

#### a. TFT-LCD panel driving section

Pin no	Symbol	I/O	Description	Remark
1	GND	-	Ground for logic circuit	
2	V <sub>CC</sub>	I	Supply voltage of logic control circuit for scan driver	
3	V <sub>GL</sub>	I	Negative power for scan driver	
4	V <sub>GH</sub>	I	Positive power for scan driver	
5	STVR	I/O	Vertical start pulse	Note 1
6	STVL	I/O	Vertical start pulse	Note 1
7	CKV	I	Shift clock input for scan driver	
8	U/D	I	UP/DOWN scan control input	Note 1,2
9	OEV	I	Output enable input for scan driver	
10	VCOM	I	Common electrode driving signal	
11	VCOM	I	Common electrode driving signal	
12	L/R	I	LEFT/RIGHT scan control input	Note 1,2
13	MOD	I	Sequential sampling and simultaneous sampling setting	Note 3
14	OEH	I	Output enable input for data driver	
15	STHL	I/O	Start pulse for horizontal scan line	Note 1
16	STHR	I/O	Start pulse for horizontal scan line	Note 1
17	CPH3	I	Sampling and shifting clock pulse for data driver	
18	CPH2	I	Sampling and shifting clock pulse for data driver	
19	CPH1	I	Sampling and shifting clock pulse for data driver	
20	V <sub>CC</sub>	I	Supply voltage of logic control circuit for data driver	
21	GND	-	Ground for logic circuit	
22	VR	I	Alternated video signal input(Red)	
23	VG	I	Alternated video signal input(Green)	
24	VB	I	Alternated video signal input(Blue)	
25	AV <sub>DD</sub>	I	Supply voltage for analog circuit	
26	AV <sub>SS</sub>	-	Ground for analog circuit	

Note 1: Selection of scanning mode (please refer to the following table)

Setting of scan control input		IN/OUT state for start pulse				Scanning direction
U/D	L/R	STVR	STVL	STHR	STHL	
GND	V <sub>CC</sub>	OUT	IN	OUT	IN	From up to down, and from left to right.
V <sub>CC</sub>	GND	IN	OUT	IN	OUT	From down to up, and from right to left.
GND	GND	OUT	IN	IN	OUT	From up to down, and from right to left.

V <sub>CC</sub>	V <sub>CC</sub>	IN	OUT	OUT	IN	From down to up, and from left to right.
-----------------	-----------------	----	-----	-----	----	--

IN: Input; OUT: Output.

Note 2: Definition of scanning direction. Refer to figure as below:

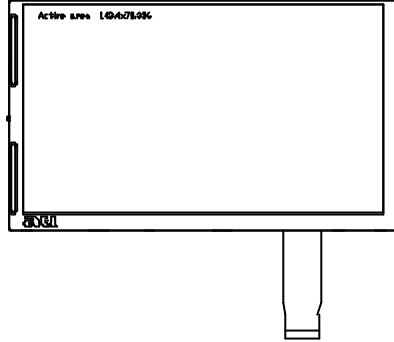

Note 3: MOD = H: Simultaneous sampling. MOD = L: Sequential sampling.  
Please set CPH2 and CPH3 to GND when MOD = H.

b. Backlight driving section (Refer to Fig. 1)

No.	Symbol	I/O	Description	Remark
1	HI	I	Power supply for backlight unit (High voltage)	
2	GND	-	Ground for backlight unit	

2. Absolute maximum ratings

Item	Symbol	Condition	Min.	Max.	Unit	Remark
Power voltage	V <sub>CC</sub>	GND=0	-0.3	7	V	
	AV <sub>DD</sub>	AV <sub>SS</sub> =0	-0.3	7	V	
	V <sub>GH</sub>	GND=0	-0.3	18	V	
	V <sub>GL</sub>		-15	0.3	V	
	V <sub>GH</sub> - V <sub>GL</sub>		-	33	V	
Input signal voltage	V <sub>i</sub>		-0.3	AV <sub>DD</sub> +0.3	V	Note 1
	V <sub>i</sub>		-0.3	V <sub>CC</sub> +0.3	V	Note 2
	VCOM		-2.9	5.2	V	

Note 1: VR, VG, VB.

Note 2: STHL, STHR, OEH, L/R, CPH1~CPH3, STVR, STVL, OEV, CKV, U/D.

3. Environment condition

Item		Condition	Spec.	Remark
Operating temperature	Panel with lighting BLU	Ambient (panel surface)	-30 ~70°C (-20 ~90°C)	Note 1,2,3
	Panel	Panel surface	-20 ~90°C	
Storage temperature	Panel with lighting BLU	Surface temperature	-40 ~95°C	Note 4
	Panel	Surface temperature	-40 ~95°C	

Note 1: Under the condition of the operating temperature, the panel would be function normal for the visual display only. For contrast, response time, and other factors related to display

quality, determine temperature using the formula  $T_a=25^{\circ}\text{C}$

Note 2: Panel surface temperature is defined as the maximum temperature of panel surface. In general, the lamp side temperature is higher than non-lamp side around  $10^{\circ}\text{C}$

Note 3: The backlight has been turned on before running about condition.

Note 4: BLU is off

#### 4. Electrical characteristics

##### a. Typical operating conditions (GND=AVss=0V, Note 4 )

Item	Symbol	Min.	Typ.	Max.	Unit	Remark
Power supply	$V_{CC}$	3	5	5.2	V	
	$AV_{DD}$	4.8	5	5.2	V	
	$V_{GH}$	14.3	15	15.7	V	
	$V_{GL}$	-10.5	-10	-9.5	V	
Video signal amplitude (VR,VG,VB)	$V_{iA}$	0.4	-	$AV_{DD}-0.4$	V	Note 1
	$V_{iAC}$	-	3	-	V	AC component
	$V_{iDC}$	-	$AV_{DD}/2$	-	V	DC component
VCOM	$V_{CAC}$	3.5	5.6	6.5	Vp-p	AC component, Note 2
	$V_{CDC}$	(1.4)	(1.7)	(2.0)	V	DC component
Input signal voltage	H Level	$V_{IH}$	$0.8V_{CC}$	-	$V_{CC}$	Note 3
	L Level	$V_{IL}$	0	-	$0.2V_{CC}$	

Note 1: Refer to Fig.4- (a).

Note 2: The brightness of LCD panel could be changed by adjusting the AC component of VCOM.

Note 3: STHL, STHR, OEH, L/R, CPH1~CPH3, STVR, STVL, OEV, CKV, U/D.

Note 4: Be sure to apply GND,  $V_{CC}$  and  $V_{GL}$  to the LCD first, and then apply  $V_{GH}$ .

##### b. Current consumption (GND=AVss=0V)

Parameter	Symbol	Condition	Min.	Typ.	Max.	Unit	Remark
Current for driver	$I_{GH}$	$V_{GH}=15V$	-	0.20	0.5	mA	
	$I_{GL}$	$V_{GL}=-10V$	-	0.80	1.5	mA	
	$I_{CC}$	$V_{CC}=5V$	-	3.0	6.0	mA	
	$I_{DD}$	$AV_{DD}=5V$	-	17.0	30	mA	

##### c. Backlight driving conditions

Parameter	Symbol	Min.	Typ.	Max.	Unit	Remark
Lamp voltage	$V_L$	-	(500)	550	Vrms	
Lamp current	$I_L$	-	6	6.5	mA rms	
Frequency	$F_L$	-	60	80	kHz	Note 4
Lamp starting voltage	$V_S$	-	-	850	Vrms	Note 1,5
		-	-	1150	Vrms	Note 2,5
		-	-	1300	Vrms	Note 3,5
Lamp life time		(25000)	(40000)	-	Hr	Note 6

Note 1:  $T_a = 25^{\circ}\text{C}$ .

Note 2:  $T_a = 0^{\circ}\text{C}$ .



Note 3:  $T_a = -30^{\circ}\text{C}$ .

Note 4: The lamp frequency should be selected as different as possible from display horizontal synchronous signal to avoid interference.

Note 5: For starting the backlight unit, the output voltage of DC/AC's transformer should be larger than the maximum lamp starting voltage.

Note 6: The "Lamp life time" is defined as the module brightness decrease to 50% original brightness at  $T_a=25^{\circ}\text{C}$ ,  $I_L=6\text{mA}$ .

## 5. AC Timing

### a. Timing conditions

Parameter	Symbol	Min.	Typ.	Max.	Unit.	Remark
Rising time	$t_r$	-	-	10	ns	Note 1
Falling time	$t_f$	-	-	10	ns	Note 1
High and low level pulse width	$t_{CPH}$	99	103	107	ns	CPH1~CPH3
CPH pulse duty	$t_{CWH}$	40	50	60	%	CPH1~CPH3
CPH pulse delay	$t_{C12}$ $t_{C23}$ $t_{C31}$	30	$t_{CPH}/3$	$t_{CPH}/2$	ns	CPH1~CPH3
STH setup time	$t_{SUH}$	20	-	-	ns	STHR,STHL
STH hold time	$t_{HDH}$	20	-	-	Ns	STHR,STHL
STH pulse width	$t_{STH}$	-	1	-	$t_{CPH}$	STHR,STHL
STH period	$t_H$	61.5	63.5	65.5	$\mu\text{s}$	STHR,STHL
OEH pulse width	$t_{OEH}$	-	1.22	-	$\mu\text{s}$	OEH
Sample and hold disable	$t_{DIS1}$	-	8.28	-	$\mu\text{s}$	
OEV pulse width	$t_{OEV}$	-	5.40	-	$\mu\text{s}$	OEV
CKV pulse width	$t_{CKV}$	-	4.18	-	$\mu\text{s}$	CKV
Clean enable time	$t_{DIS2}$	-	3.74	-	$\mu\text{s}$	
Horizontal display start	$t_{SH}$	-	0	-	$T_{CPH}/3$	
Horizontal display timing range	$t_{DH}$	-	1200	-	$T_{CPH}/3$	
STV setup time	$t_{SUV}$	400	-	-	ns	STVL,STVR
STV hold time	$t_{HDV}$	400	-	-	ns	STVL,STVR
STV pulse width	$t_{STV}$	-	-	1	$t_H$	STVL,STVR
Horizontal lines per field	$t_V$	256	262	268	$t_H$	Note 2
Vertical display start	$t_{SV}$		3	-	$t_H$	
Vertical display timing range	$t_{DV}$		234	-	$t_H$	
VCOM rising time	$t_{rCOM}$		-	5	$\mu\text{s}$	
VCOM falling time	$t_{fCOM}$		-	5	$\mu\text{s}$	
VCOM delay time	$t_{DCOM}$		-	3	$\mu\text{s}$	
RGB delay time	$t_{DRGB}$		-	1	$\mu\text{s}$	

Note 1: For all of the logic signals.

Note 2: Please don't use odd horizontal lines to drive LCD panel for both odd and even field simultaneously.

b. Timing diagram

Please refer to the attached drawing, from Fig.2 to Fig.6.

**C. Optical specification (Note 1)**

Item		Symb	Condition	Min.	Typ.	Max.	Unit	Remark
Response time	Rise	Tr	$\theta = 0^\circ$	-	15	50	ms	Note 2,4
	Fall	Tf		-	20	60	ms	
Contrast ratio		CR	At optimized Viewing angle	100	300	-		Note 3,4
Viewing angle	Top		$CR \geq 10$	20	40	-	deg.	Note 4,6
	Bottom			40	55	-		
	Left			45	60	-		
	Right			45	60	-		
	Top		$CR \geq 5$	30	50	-	deg.	Note 4,5
	Bottom			60	70	-		
	Left			60	70	-		
	Right			60	70	-		
Brightness		$Y_L$	$I_L=6mA, 25^\circ C$	400	500	-	nit	Note 6
			$I_L=9.5mA, -10^\circ C, 1min$	190	230		nit	
			$I_L=9.5mA, -20^\circ C, 1min$	150	180	-	nit	
White chromaticity		X	$\theta = 0^\circ$	0.26	0.31	0.36		Note 6
		Y	$\theta = 0^\circ$	0.28	0.33	0.38		

Note 1 : Ambient temperature =25°C. And lamp current  $I_L = 6$  mA rms. To be measured in the dark room and to be measured on the center area of panel with a viewing cone of  $1^\circ$  by Topcon luminance meter BM-5, after 10 minutes operation.

Note 2. Definition of response time:

The output signals of photo detector are measured when the input signals are changed from “black” to “white” (falling time) and from “white” to “black” (rising time), respectively.

The response time is defined as the time interval between the 10% and 90% of amplitudes. Refer to figure as below.

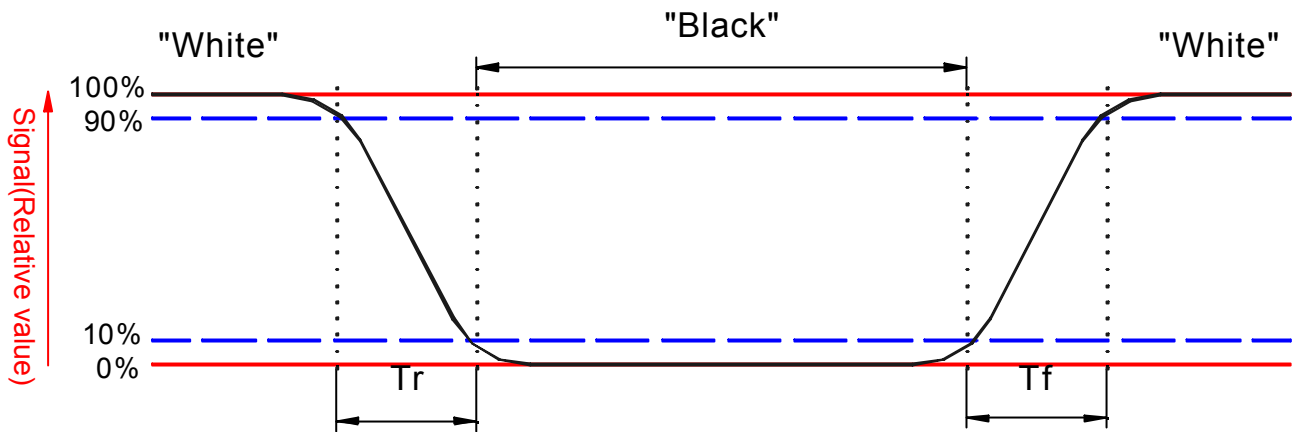

Note 3. Definition of contrast ratio:

Contrast ratio is calculated with the following formula.

$$\text{Contrast ratio (CR)} = \frac{\text{Photo detector output when LCD is at "White" state}}{\text{Photo detector output when LCD is at "Black" state}}$$

Note 4. White  $V_i = V_{i50} + 1.5V$

Black  $V_i = V_{i50} \pm 2.0V$

"±" means that the analog input signal swings in phase with  $V_{COM}$  signal.

"∓" means that the analog input signal swings out of phase with  $V_{COM}$  signal.

$V_{i50}$  : The analog input voltage when transmission is 50%

The 100% transmission is defined as the transmission of LCD panel when all the input terminals of module are electrically opened.

Note 5. Definition of viewing angle, refer to figure as below.

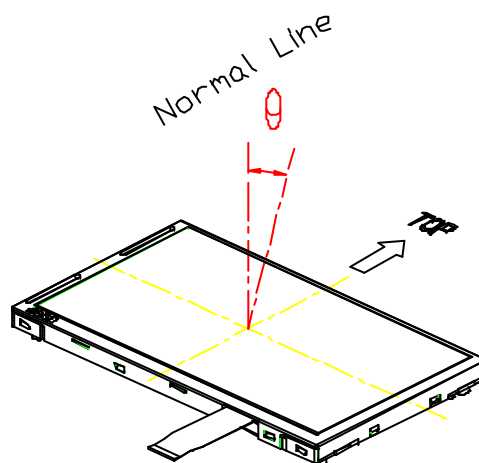

Note 6. Measured at the center area of the panel when all the input terminals of LCD panel are electrically opened.

Note 7. It is combine with application circuit which AU Optronics recommendation.

**D. Reliability test items(Note 2):**

No.	Test items	Conditions	Remark
1	High temperature storage	Ta= 95°C                      240Hrs	
2	Low temperature storage	Ta= -40°C                      240Hrs	
3	High temperature operation	Ta= 70°C                      240Hrs	
4	Low temperature operation	Ta= -20°C                      240Hrs	
5	High temperature and high humidity	Ta= 60°C, 90% RH      240Hrs	Operation
6	Heat shock	-30°C~85°C/200 cycles 1Hrs/cycle	Non-operatio
7	Electrostatic discharge	±200V,200pF(0Ω), once for each terminal	Non-operatio n
8	Vibration	Frequency range : 10~55Hz Stoke : 1.5mm Sweep : 10 ~ 55 ~ 10Hz 2 hours for each direction of X,Y,Z (6 hours for total)	JIS C7021, A-10 condition A
9	Mechanical shock	100G, 6ms, $\pm X, \pm Y, \pm Z$ 3 times for each direction	JIS C7021, A-7 condition C
10	Vibration (with carton)	Random vibration: 0.015G <sup>2</sup> /Hz from 5~200Hz -6dB/octave from 200~500Hz	IEC 68-34
11	Drop (with carton)	Height: 60cm 1 corner, 3 edges, 6 surfaces	JIS Z0202

Note 1: Ta: Ambient temperature.

Note 2: In the standard conditions, there is not display function NG issue occurred. All the cosmetic specification is judged before the reliability stress.

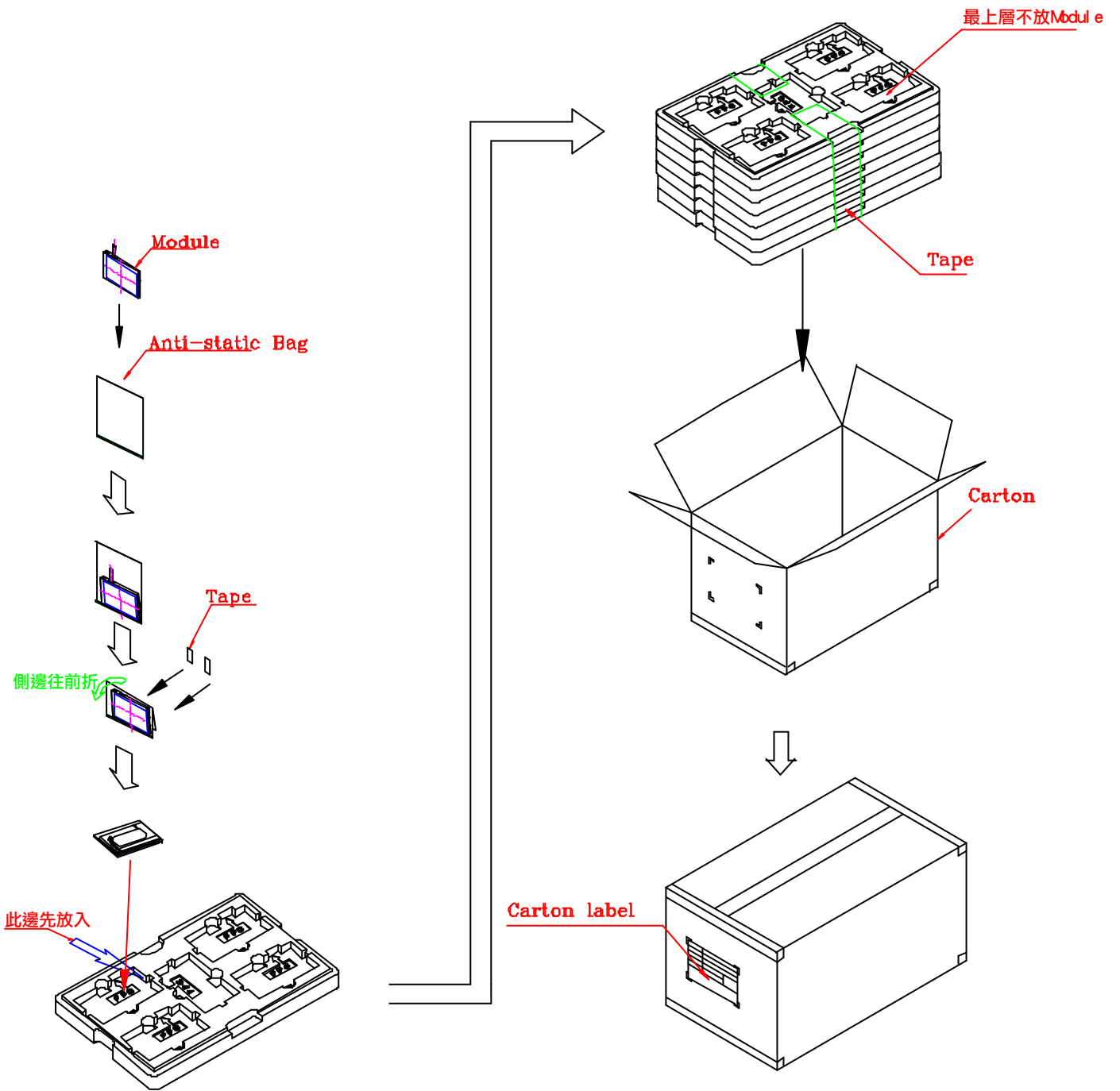

Max. Capacity: 30 Modules  
Max. Weight: 7 Kg  
Carton outline: 520mm\*340mm\*250mm

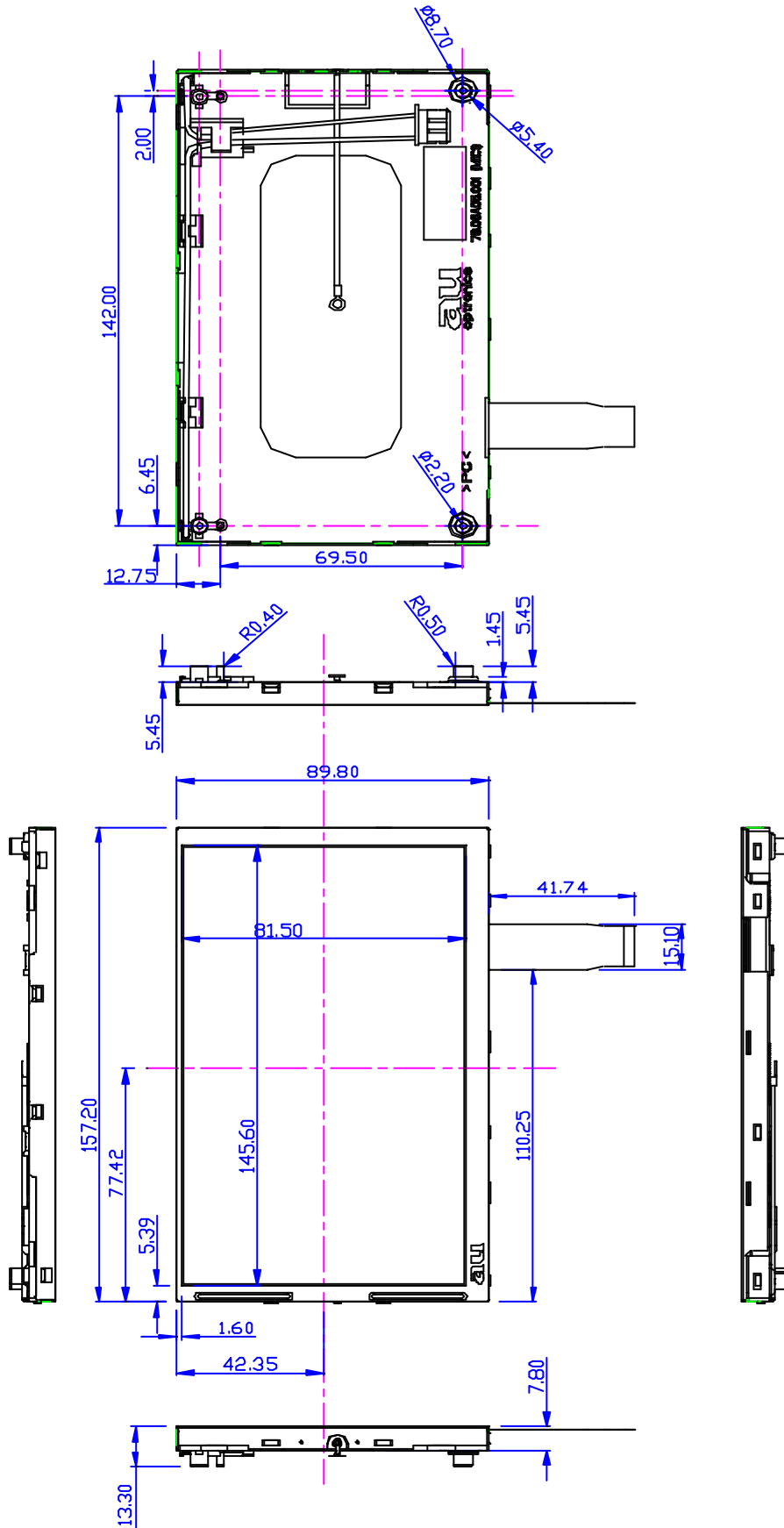
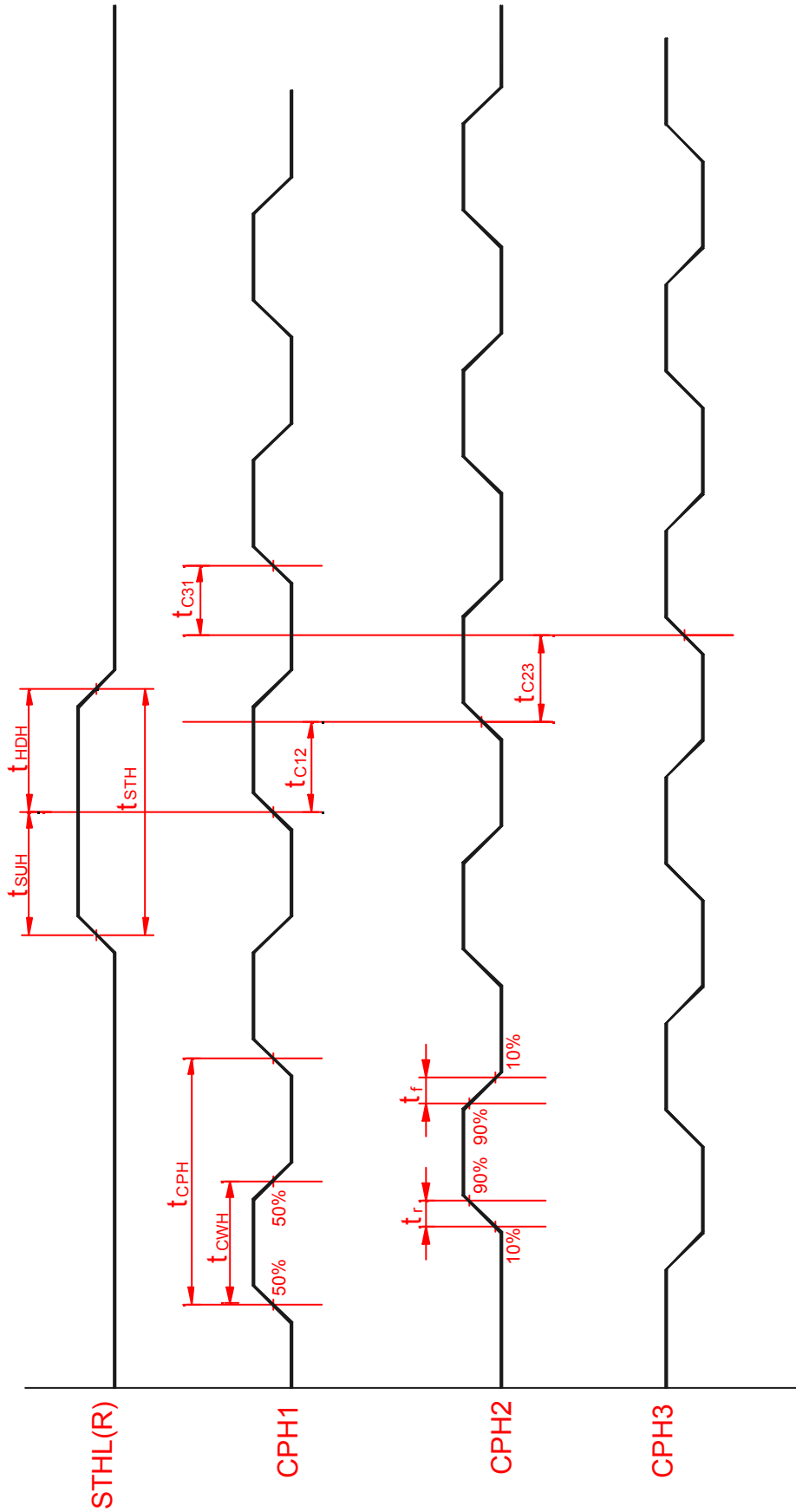
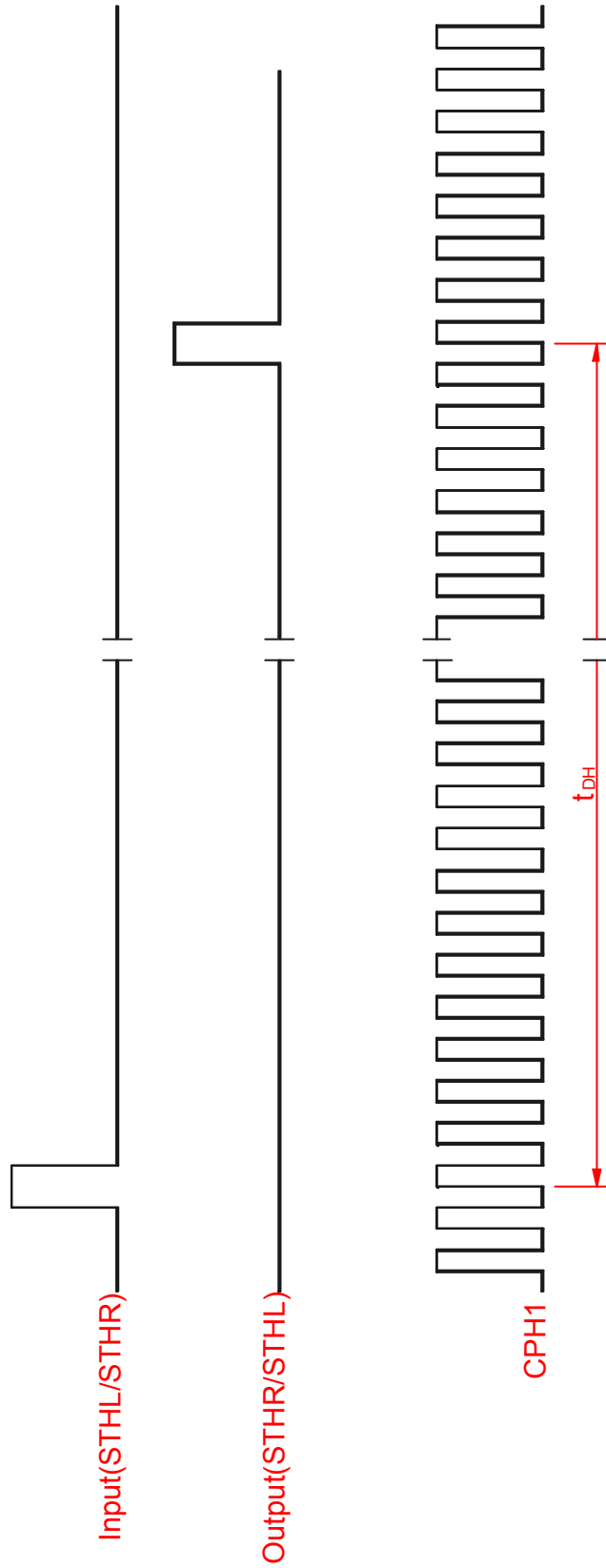

Fig.1-(a) Outline dimension of TFT-LCD module

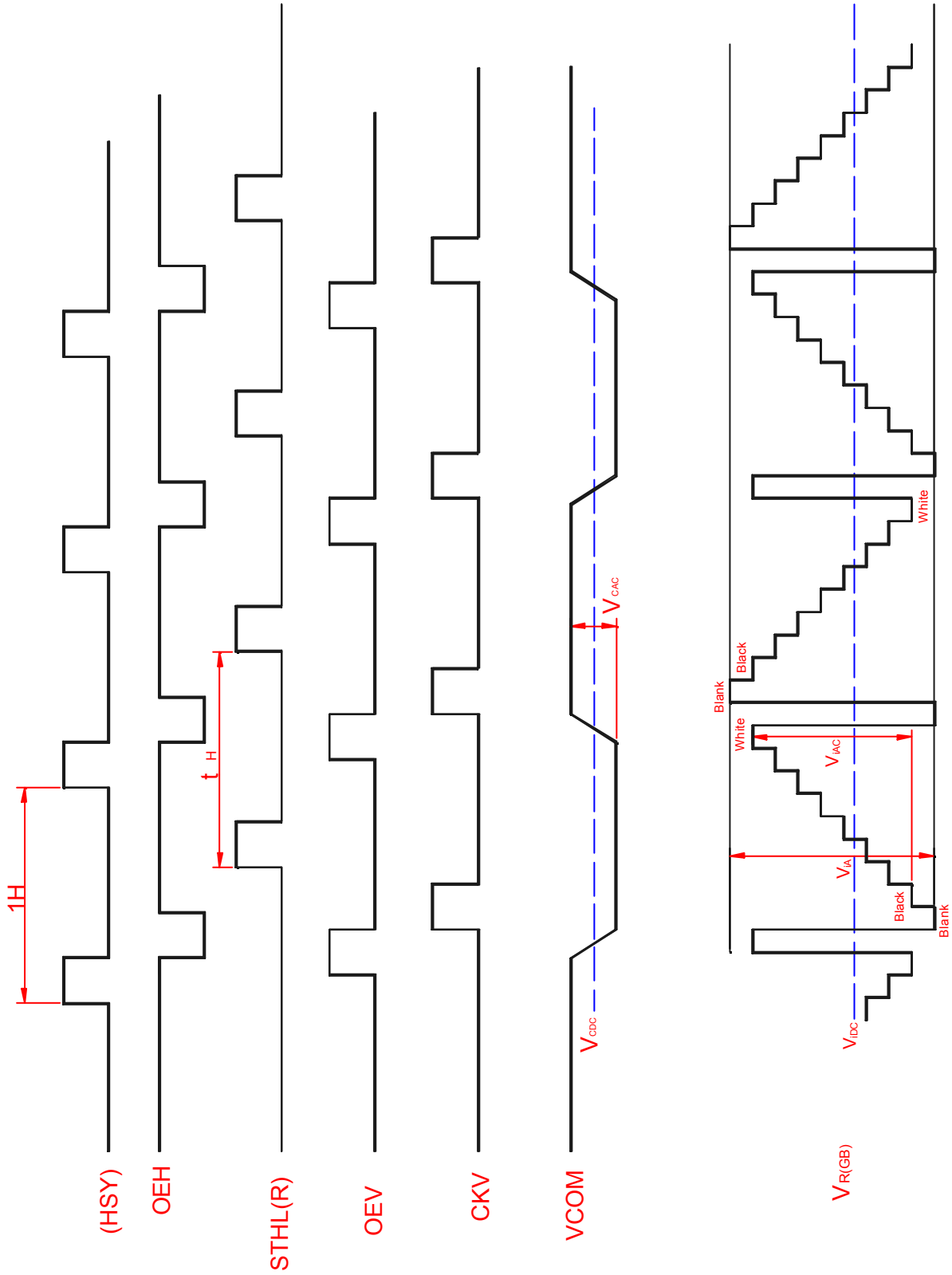

**Fig.2 Sampling clock timing**

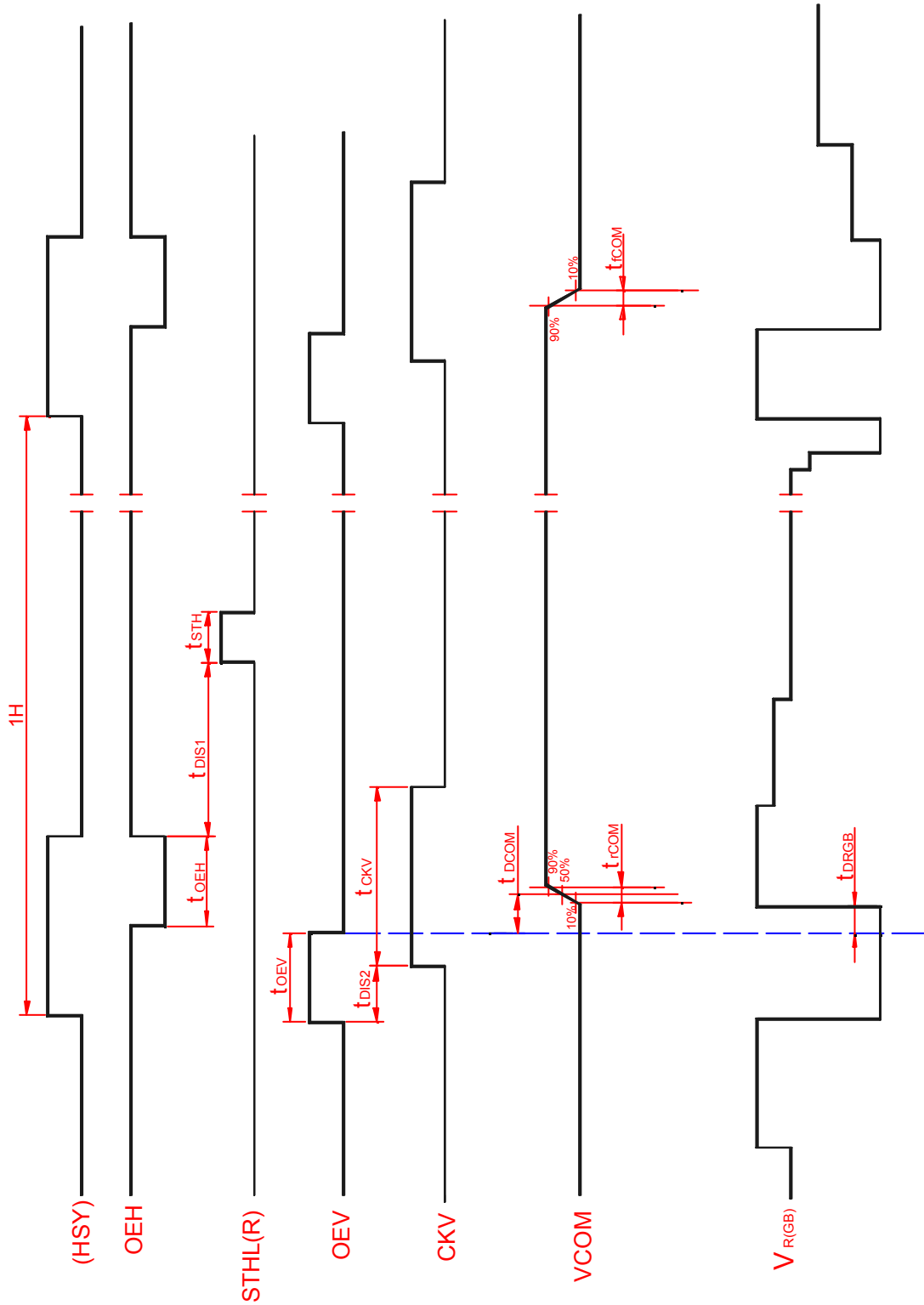

**Fig.3 Horizontal display timing range**



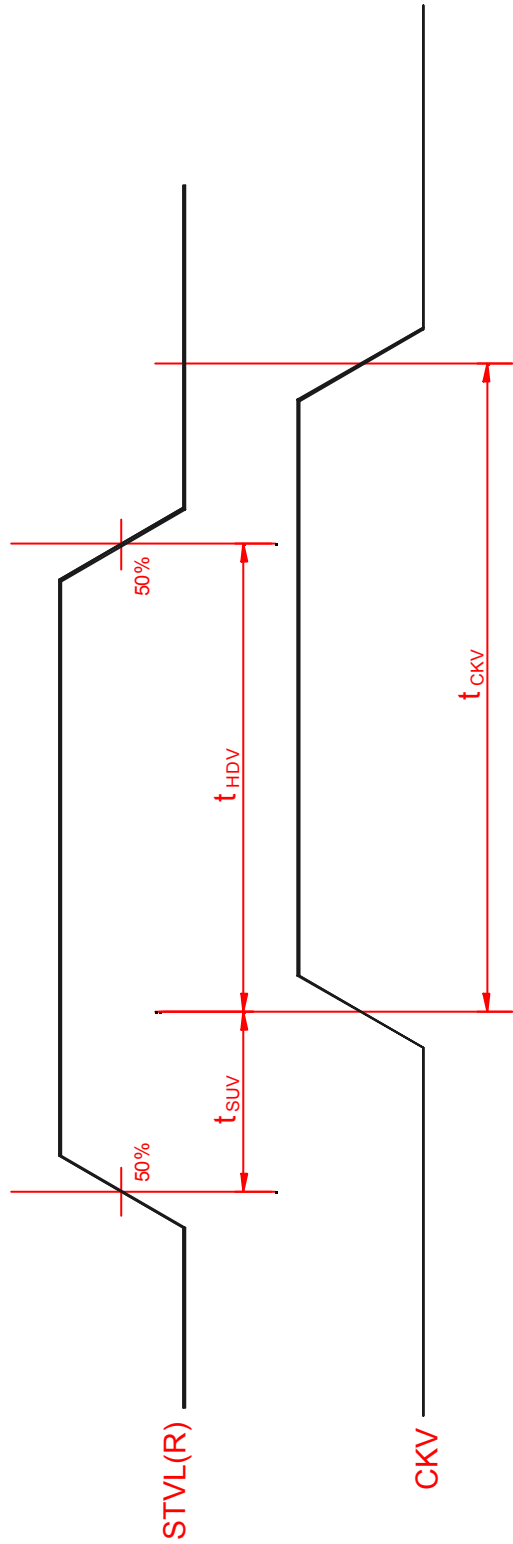

**Fig.4-(a) Horizontal timing**



Note: The falling edge of OEV should be synchronized with the falling edge of OEH

**Fig.4-(b) Detail horizontal timing**



**Fig.5 Vertical shift clock timing**

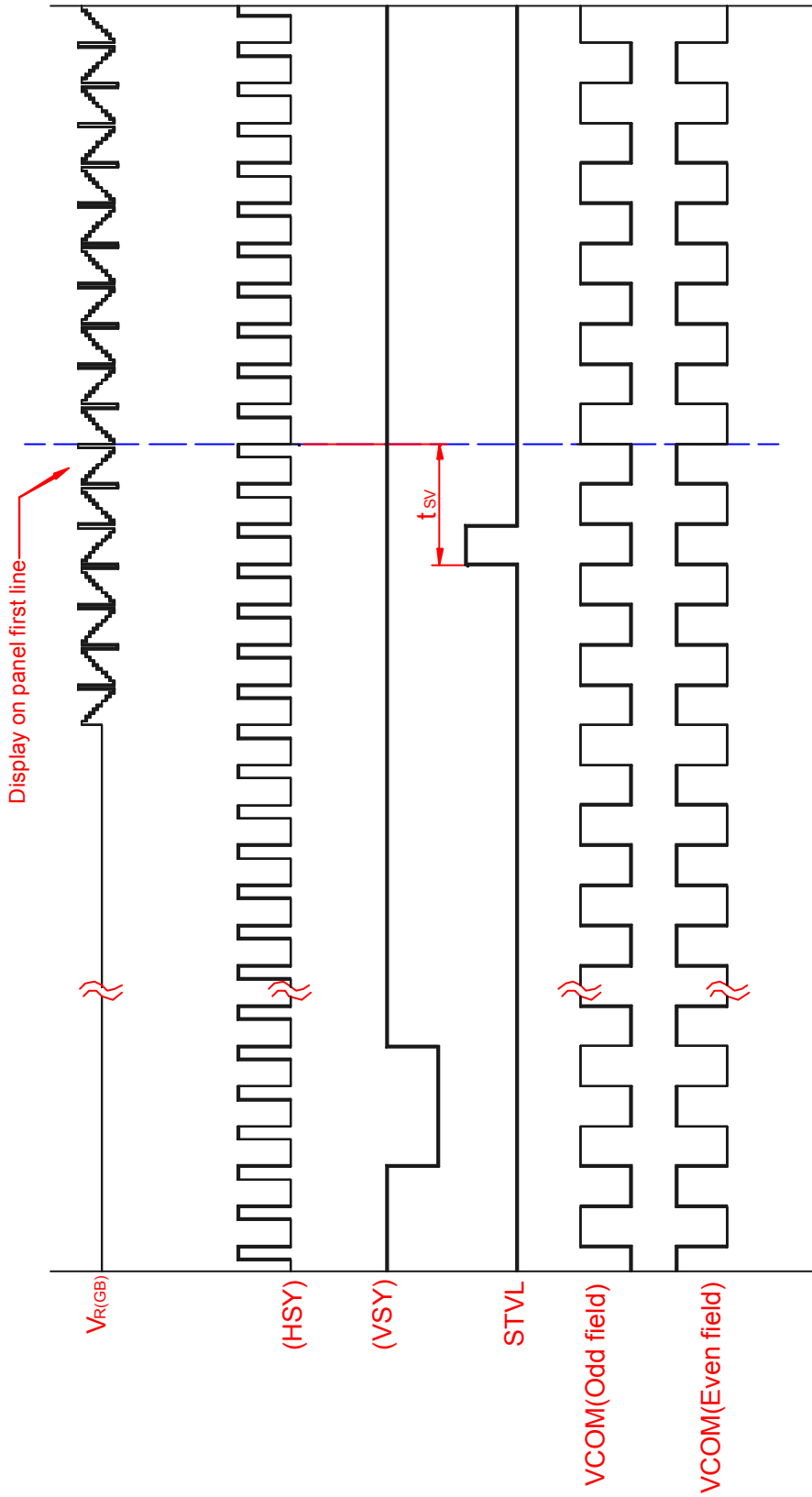

**Fig.6-(a) Vertical timing (From up to down)**

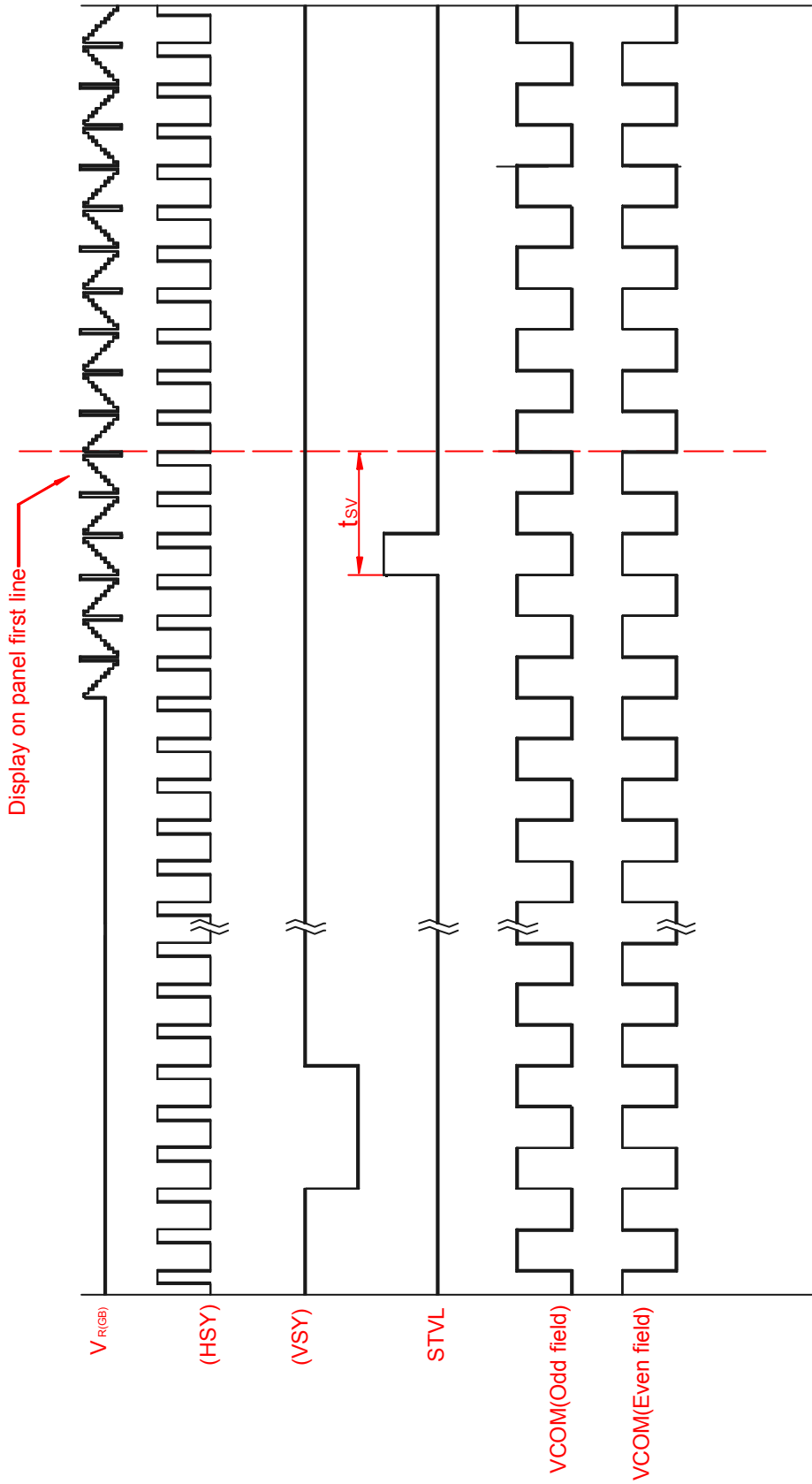

**Fig.6-(b) Horizontal timing (From down to up)**