



Doc. version :	0.0
Total pages :	17
Date :	2008/2/20

Product Specification

8.9" COLOR TFT-LCD MODULE

MODEL NAME: A089SW01 V1

- < > Preliminary Specification
- < > Final Specification

Note: The content of this specification is subject to change.

© 2007 AU Optronics
All Rights Reserved,
Do Not Copy.

Contents

<u>A.</u>	<u>General Description</u>	<u>3</u>
<u>B.</u>	<u>Features</u>	<u>3</u>
<u>C.</u>	<u>Function Block</u>	<u>3</u>
<u>D.</u>	<u>General Information</u>	<u>4</u>
<u>E.</u>	<u>Outline Dimension.....</u>	<u>5</u>
	1. TFT-LCD Module – Front View	5
	2. TFT-LCD Module – Rear View.....	6
<u>F.</u>	<u>Electrical Specifications</u>	<u>7</u>
	1. FPC Pin Assignment Recommended connector : IPEX 20347-340E-12	7
	2. Absolute Maximum Ratings	8
	3. Absolute Rating of Backlight Unit	8
<u>G.</u>	<u>Electrical Characteristics.....</u>	<u>9</u>
	1. TFT-LCD Typical Operation Condition	9
	2. Signal Electrical Characteristics.....	10
	3. Backlight Driving Conditions	11
<u>H.</u>	<u>Signal Characteristic.....</u>	<u>11</u>
	1. The Input Data(LVDS) Format.....	11
	2. Interface Timing.....	12
	3. Power ON/OFF Sequence	13
<u>I.</u>	<u>Optical specification (Note 1, 2)</u>	<u>14</u>
<u>J.</u>	<u>Absolute Ratings of Ambient Environment</u>	<u>16</u>
<u>K.</u>	<u>Packing Form.....</u>	<u>17</u>

A. General Description

A089SW01 is an amorphous transmissive type TFT (Thin Film Transistor) LCD (Liquid crystal Display). This model is composed of TFT-LCD, PCB (printed circuit board) with drive IC, FPC (flexible printed circuit), and backlight unit. The timing controller is embedded, so it is easy to design for consumer product.

B. Features

- 8.9-inch display size
- SWVGA (1024x600) resolution and stripe dot arrangement
- Built in timing controller
- LED backlight
- SYNC + DE Mode
- 6 bits LVDS interface support
- 262K color supported
- Wide viewing angle
- RoHS compliant green design
- Singal power 3.3V
- LED power 5V

C. Function Block

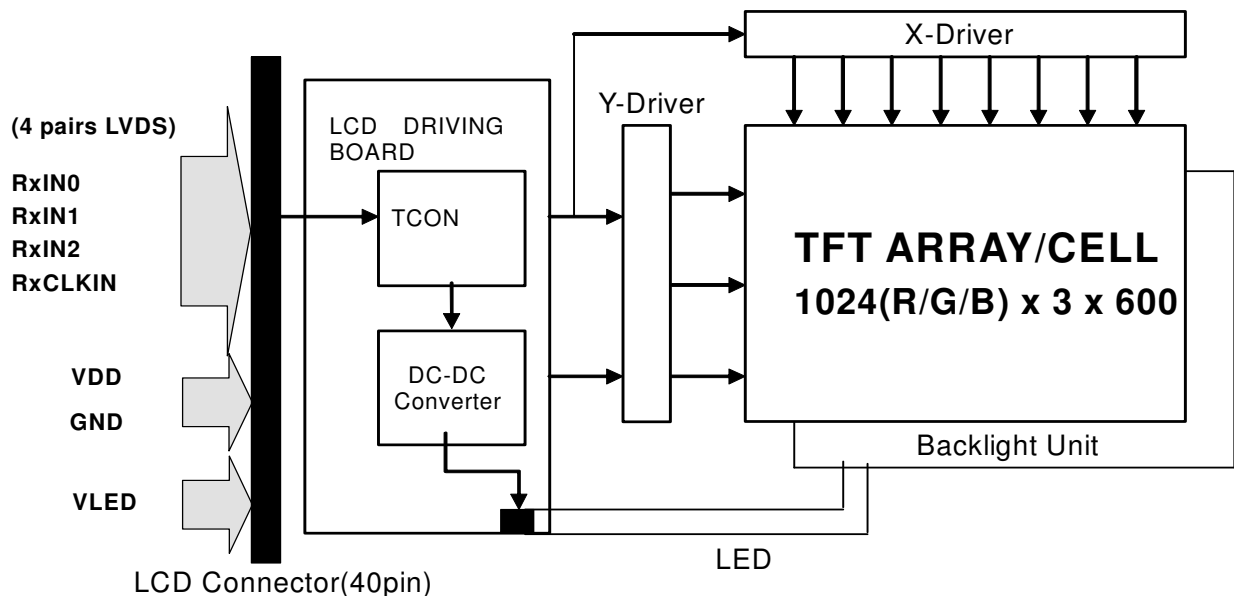

D. General Information

NO.	Item	Unit	Specification	Remark
1	Display Resolution	dot	1024RGB(H)×600(V)	
2	Active Area	mm	195.07(H) x 113.4(V)	
3	Screen Size	inch	8.9 (Diagonal)	
4	Pixel Pitch	mm	0.1905(H)×0.189(V)	
5	Color Configuration	--	R. G. B. Stripe	Note 1
6	Color Depth	--	262K Colors	Note 2
7	Overall Dimension	mm	213.36(H) × 129.55(V) × 5.15+/-0.3(T) (with mylar)	Note 3
8	Weight	g	190g	
9	Panel surface treatment	--	Glare	
10	Display Mode	--	Normally White	

Note 1: Below figure shows dot stripe arrangement.

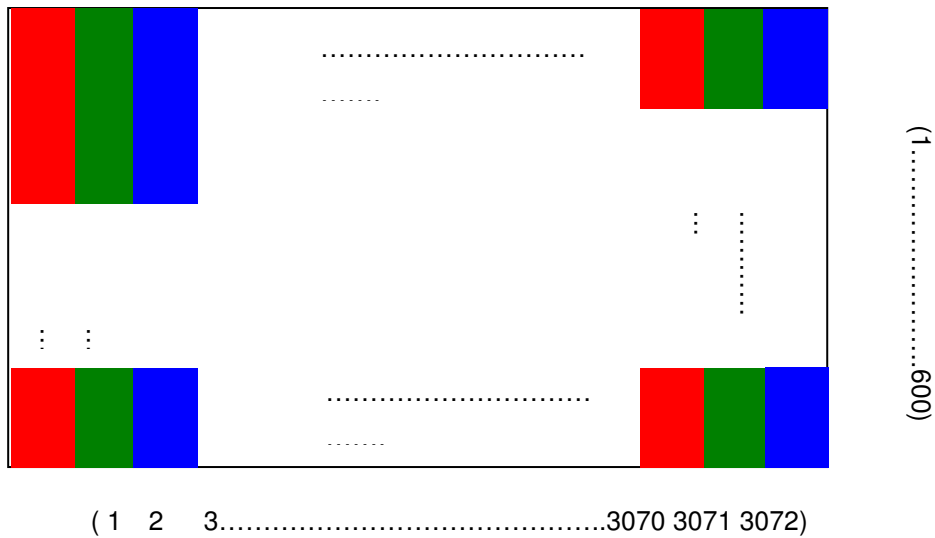

Note 2: The 262K color display depends on 6-bit data signal.

Note 3: Not include boss. Refer next page to get further information.

E. Outline Dimension
1. TFT-LCD Module – Front View

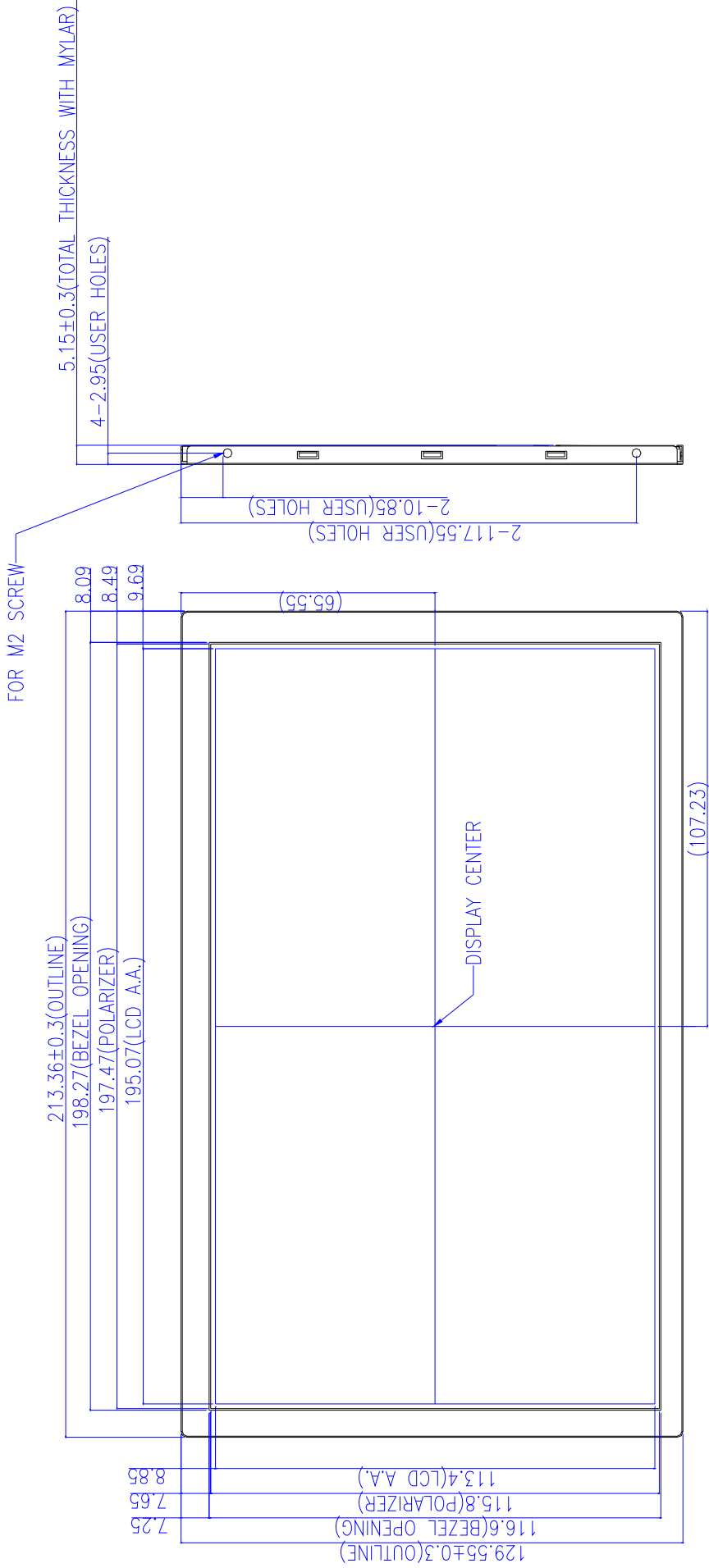

NOTES:

- 1.GENERAL TOLERANCE IS ±0.3 mm
- 2.I/F CONNECTOR TO BE IPX 20347-340E-12
- 3.ALLOWED DEPTH OF USER HOLE FOR SCREW IS 2.0mm Max.

2. TFT-LCD Module – Rear View

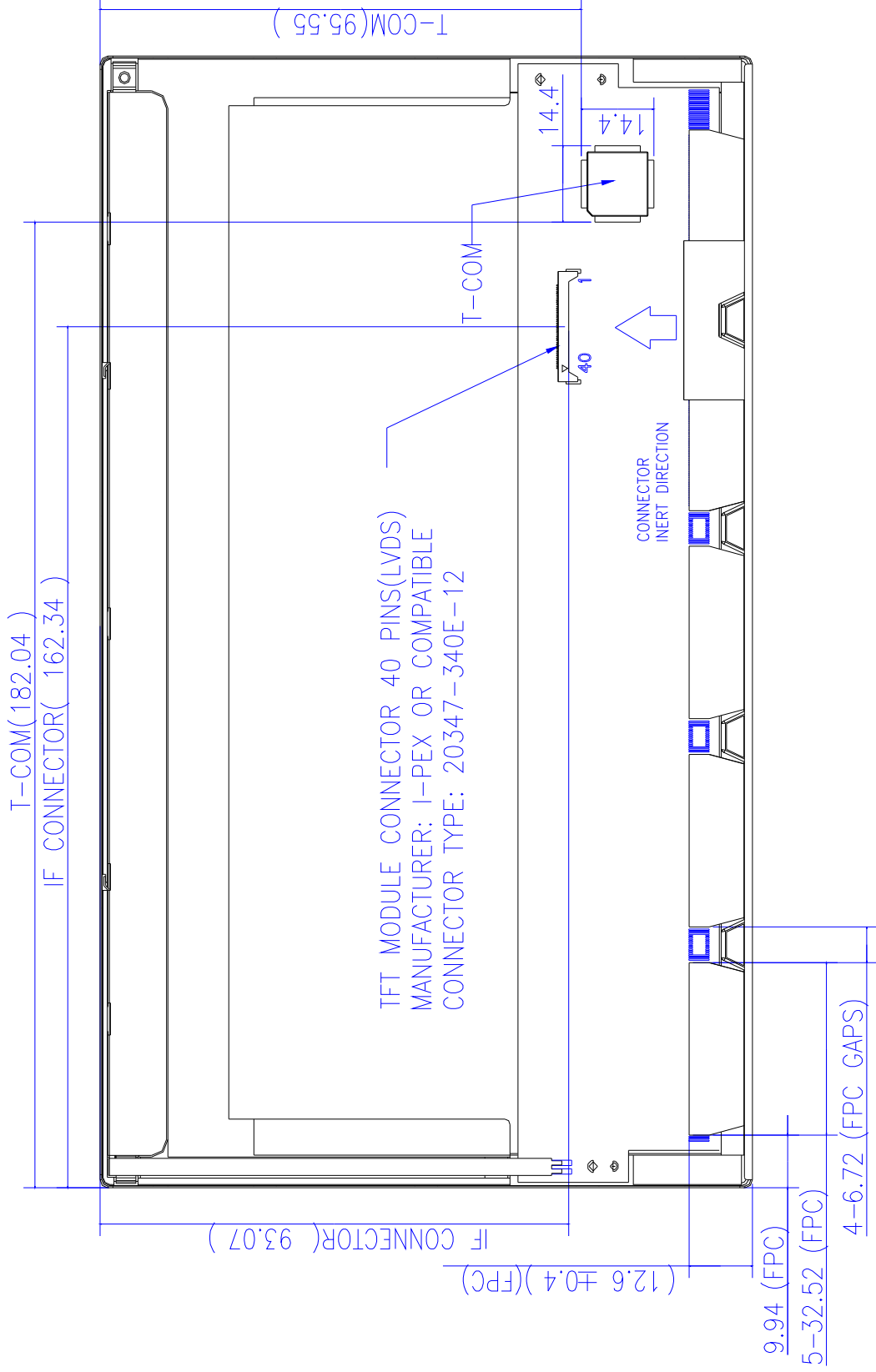

F. Electrical Specifications

1. FPC Pin Assignment Recommended connector : IPEX 20347-340E-12

Pin no	Symbol	I/O	Description	Remark
1	GND	G	Ground	
2	VDD	P	+3.3V Power Supply	
3	VDD	P	+3.3V Power Supply	
4	V _{EDID}	--	+3.3V EDID Power	
5	NC	P	No Connection (Reserve for AUO test)	
6	CLK _{EDID}	--	EDID Clock Input	
7	DATA _{EDID}	--	EDID Data Input	
8	RxIN0-	I	LVDS differential data input(R0-R5, G0)	
9	RxIN0+	I	LVDS differential data input(R0-R5, G0)	
10	GND	G	Ground	
11	RxIN1-	I	LVDS differential data input(G1-G5, B0-B1)	
12	RxIN1+	I	LVDS differential data input(G1-G5, B0-B1)	
13	GND	G	Ground	
14	RxIN2-	I	LVDS differential data input(B2-B5, HS, VS, DE)	
15	RxIN2+	I	LVDS differential data input(B2-B5, HS, VS, DE)	
16	GND	G	Ground	
17	RxCLKIN-	I	LVDS differential clock input	
18	RxCLKIN+	I	LVDS differential clock input	
19	GND	G	Ground	
20	NC	--	No Connection (Reserve for AUO test)	
21	NC	--	No Connection (Reserve for AUO test)	
22	GND	G	Ground	
23	NC	--	No Connection (Reserve for AUO test)	
24	NC	--	No Connection (Reserve for AUO test)	
25	GND	G	Ground	
26	NC	--	No Connection (Reserve for AUO test)	
27	NC	--	No Connection (Reserve for AUO test)	
28	GND	G	Ground	
29	VLED	P	LED Power Supply +5V	
30	VLED	P	LED Power Supply +5V	
31	VLED_GND	G	LED Ground	
32	VLED_GND	G	LED Ground	
33	VLED_GND	G	LED Ground	
34	NC	--	No Connection (Reserve for AUO test)	

35	NC	--	No Connection (Reserve for AUO test)	
36	NC	--	No Connection (Reserve for AUO test)	
37	NC	--	No Connection (Reserve for AUO test)	
38	S_PWMIN	I	System PWM signal Input	Note1
39	NC / ENB	--	No Connection or ENB pin input	Note 2
40	NC	--	No Connection (Reserve for AUO test)	

I: Input pin; P: Power pin; G: Ground pin;

Note 1: The PWM pin should not connect to ground, it should pull-high if not adjust brightness.

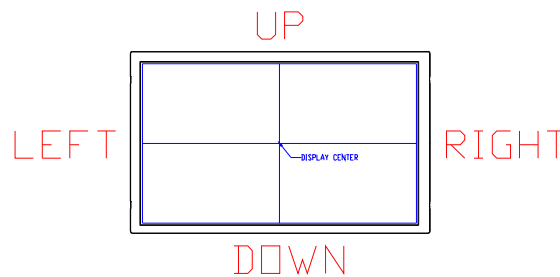

Note 2: Pin 39 connect to LED ENB pin. By the way, AUO pull high this pin via 100K resistor then connect to 3.3V. Customer can input ENB signal to control LED driver or let this pin NC and control LED driver by PWM duty.

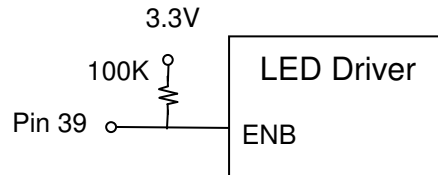

2. Absolute Maximum Ratings

Items	Symbol	Product Specification		Unit
		Min.	Max.	
Power Voltage	VCC	-0.3	4	V
Operation Temperature	Topa	0	60	°C
Storage Temperature	Tstg	-20	50	°C

Note 1: Functional operation should be restricted under normal ambient temperature.

3. Absolute Rating of Backlight Unit

Items	Symbol	Product Specification		Unit
		Min.	Max.	
LED Driving Voltage	VLED		6	V

G. Electrical Characteristics

The following items are measured under a stable condition and suggested application circuit.

1. TFT-LCD Typical Operation Condition

Symble	Parameter	Min.	Typ.	Max.	Unit	Condition
VCC	Logic/LCD Voltage	2.7	3.3	3.6	[Volt]	
ICC	VCC current	-	260		[mA]	VCC=3.3V,Black Pattern,at 60Hz
Irush	LCD Inrush Current	-	TBD	-	[mA]	VCC rising time = 470us
PCC	VCC Power		0.858	-	[Watt]	VCC=3.3V , Black Pattern,at 60Hz

Note: Measurement conditions:

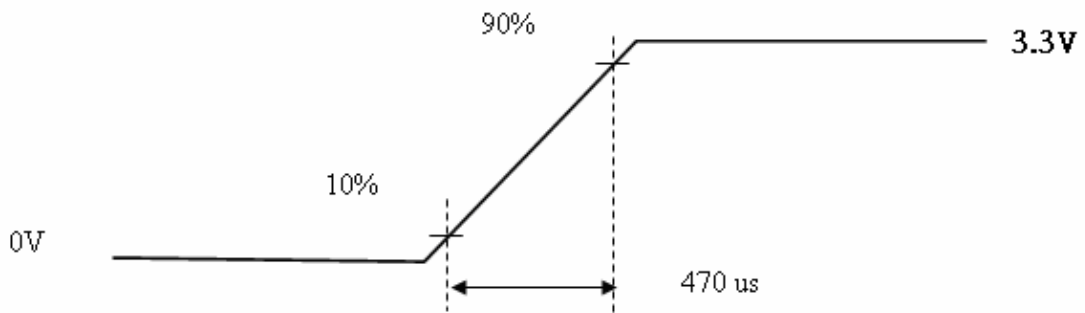
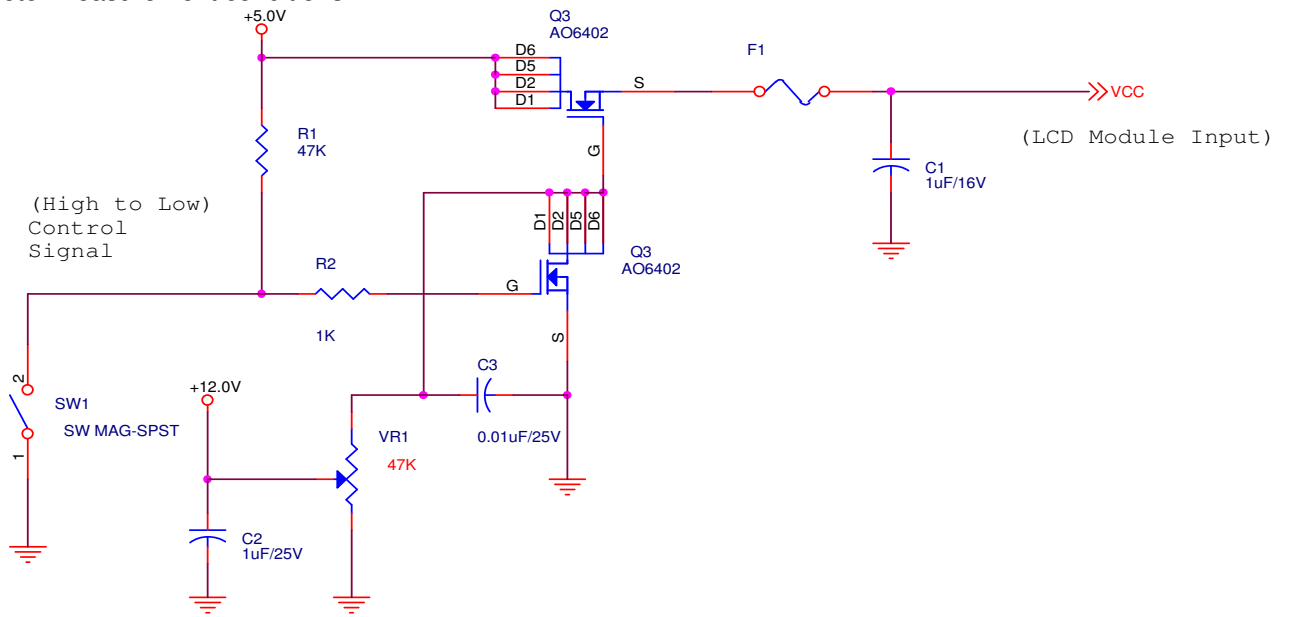

Vin rising time

2. Signal Electrical Characteristics

Input signals shall be low or Hi-Z state when Vcc is off

It is recommended to refer the specifications of SN75LVDS82DGG (Texas Instruments) in detail.

Each signal characteristics are as follows;

Symbol	Parameter	Min	Typ	Max	Units	Condition
VTH	Differential Input High Threshold	-	-	100	[mV]	VICM = 1.2V
VTL	Differential Input Low Threshold	-100	-	-	[mV]	VICM = 1.2V
VID	Input Differential Voltage	250	350	450	[mV]	
VICM	Differential Input Common Mode Voltage	1.0	1.25	2	[V]	VTH/VTL = ± 100mV

Note: LVDS Signal Waveform

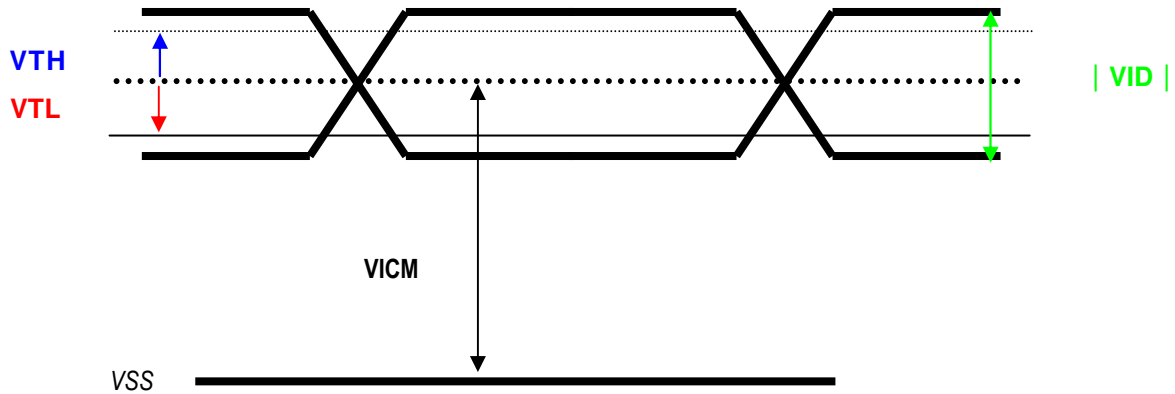

3. Backlight Driving Conditions

Parameter	Symbol	Min.	Typ.	Max.	Unit	Remark
LED Power Voltage	VLED	4.5	5	5.5	V	---
LED Power Current	ILED		375	400	mA	Input=5V
LED Inrush Current	I_{inrush}		TBD		mA	
LED PWM Frequency	L_{freq}	---	---	1K	Hz	
LED Life Time	L_L	10,000	---	---	Hr	Note 2, 3

Note 1: The LED driving condition is defined for LED module (24 LED).

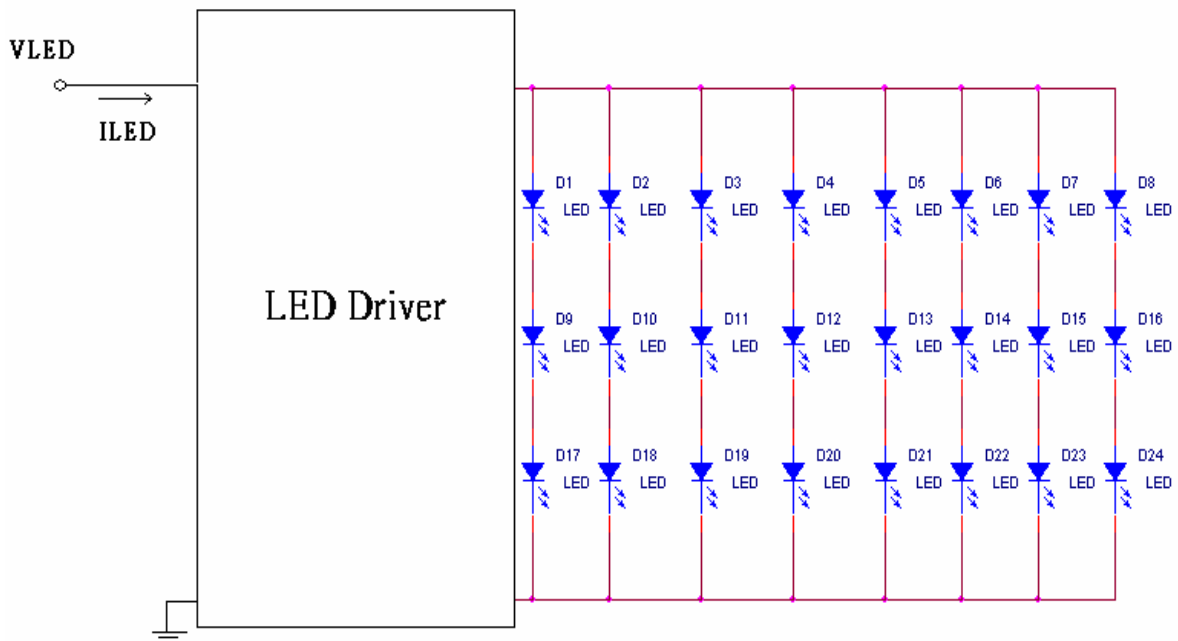

Note 2: Define “LED Lifetime”: brightness is decreased to 50% of the initial value. LED Lifetime is restricted under normal condition, ambient temperature = 25°C and LED lightbar voltage = 10V.

Note 3: If it uses larger LED lightbar voltage more than 10V, it maybe decreases the LED lifetime.

H. Signal Characteristic

1. The Input Data(LVDS) Format

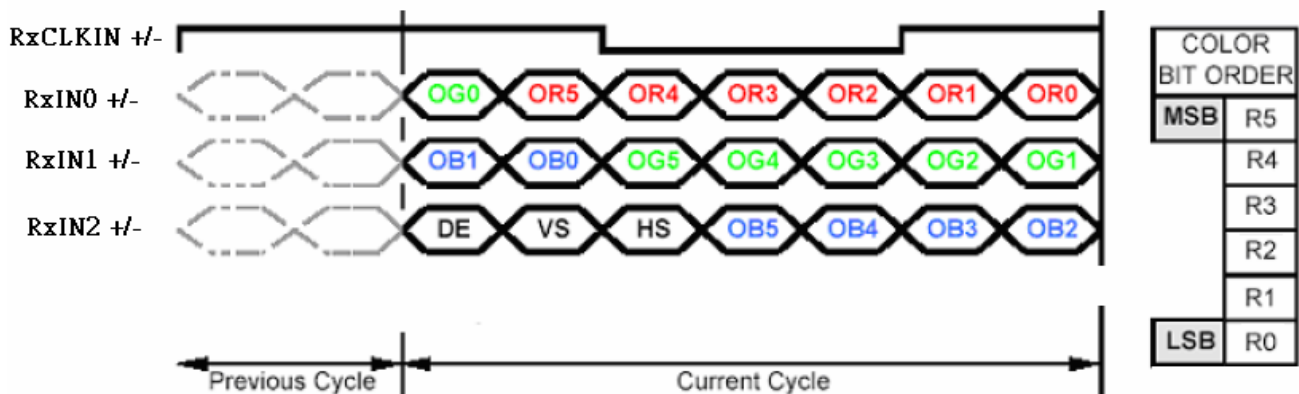

Note1: Please follow PSWG.

Note2: 6-bit in

Note3: R/G/B data 5:MSB, R/G/B data 0:LSB

2. Interface Timing

a. Timing Characteristics

Signal	Item	Symbol	Min	Typ	Max	Unit
Clock Timing	Clock frequency	$1/T_{\text{CLOCK}}$		50.4	85	MHz
Horizontal Timing	Horizontal active	T_{HD}	1024	1024	1024	T_{CLOCK}
	Horizontal blanking	T_{HB}	22	320	510	T_{CLOCK}
	Horizontal period	T_{H}	1046	1344	1534	T_{CLOCK}
Vertical Timing	Vertical active	T_{VD}	600	600	600	Th
	Vertical blanking	T_{VB}	3	25	50	Th
	Vertical period	T_{V}	603	625	650	Th

Note: Typical value refer to VESA STANDARD

b. Timing Diagram

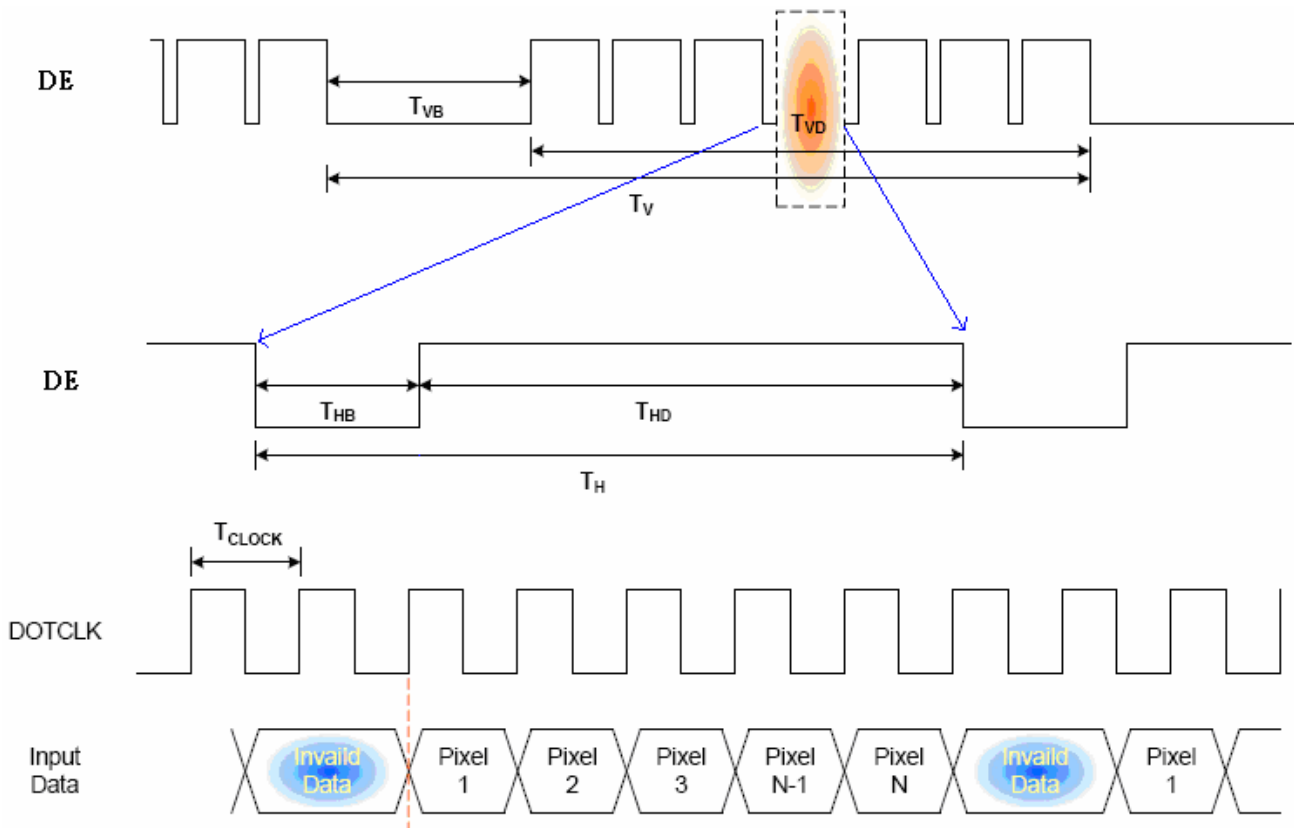

3. Power ON/OFF Sequence

Vcc power and LED on/off sequence is as follows. Interface signals are also shown in the chart. Signals from any system shall be Hi-Z state or low level when Vcc is off.

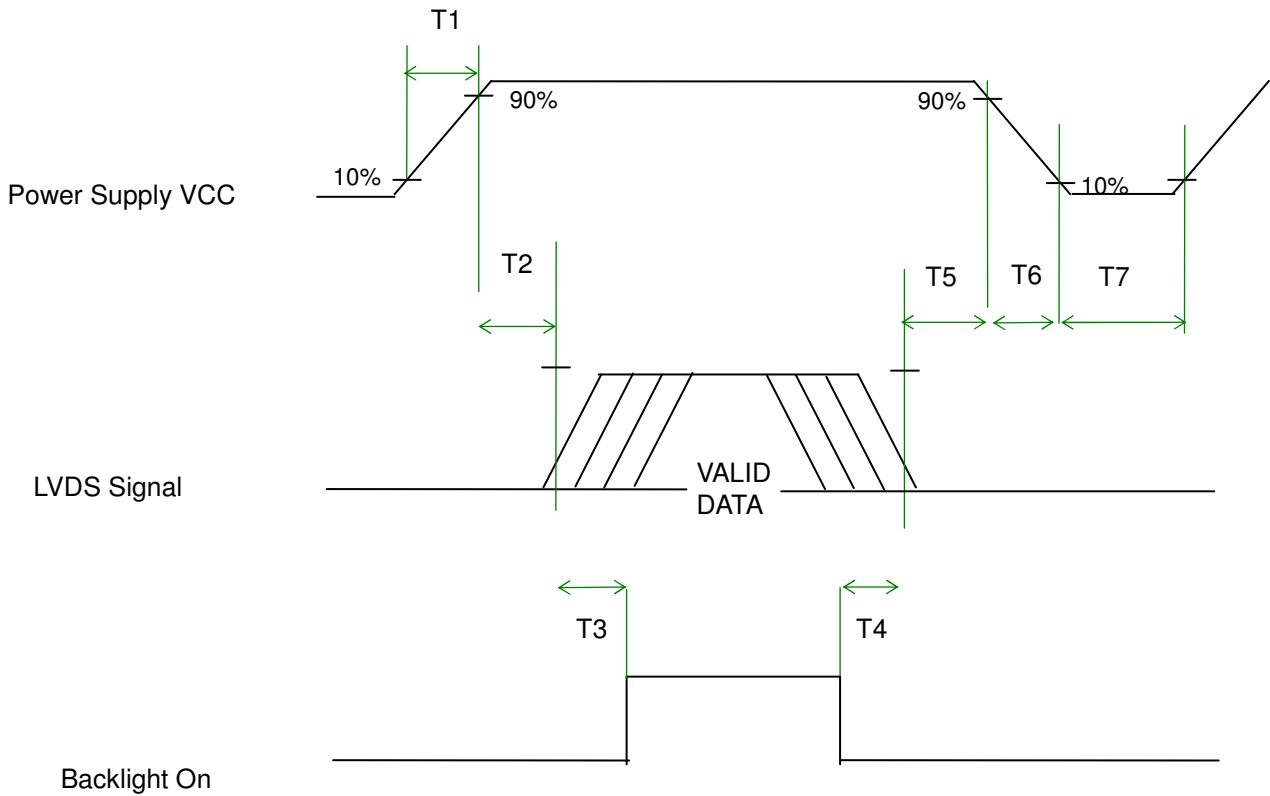

Power Sequence Timing

Parameter	Value			Unit
	Min.	Typ.	Max.	
T1	0.5	-	10	[ms]
T2	30	40	50	[ms]
T3	200	-	-	[ms]
T4	100	-	-	[ms]
T5	0	16	50	[ms]
T6	-	-	10	[ms]
T7	1000	-	-	[ms]

I. Optical specification (Note 1, 2)

Item	Symbol	Condition	Min.	Typ.	Max.	Unit	Remark
Response Time							
Rise	Tr	$\theta=0^\circ$	-	12	20	ms	Note 3
Fall	Tf		-	18	30	ms	
Contrast ratio	CR	At optimized viewing angle	200	300	-		Note 4
Viewing Angle		$CR \geq 10$					Note 5
Top			20	-	deg.		
Bottom			40	-			
Left			40	-			
Right			40	-			
Brightness	Y_L	$\theta=0^\circ$	150	180	-	cd/m^2	Note 6
White Chromaticity	X	$\theta=0^\circ$	0.26	0.31	0.36		
	y	$\theta=0^\circ$	0.28	0.33	0.38		

Note 1: Ambient temperature $\approx 25^\circ C$, and LED lightbar current $I = 160\text{ mA}$. To be measured in the dark room.

Note 2: To be measured on the center area of panel with a viewing cone of 1° by Topcon luminance meter BM-7, after 15 minutes operation.

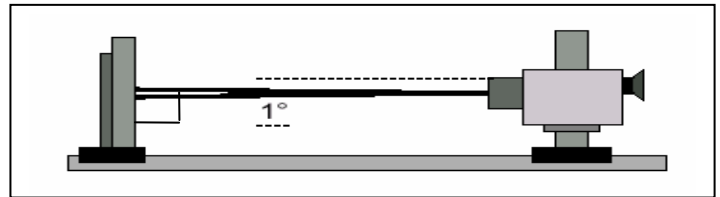

Note 3. Definition of response time:

The output signals of photo detector are measured when the input signals are changed from "black" to "white" (falling time) and from "white" to "black" (rising time), respectively.

The response time is defined as the time interval between the 10% and 90% of amplitudes. Refer to figure as below.

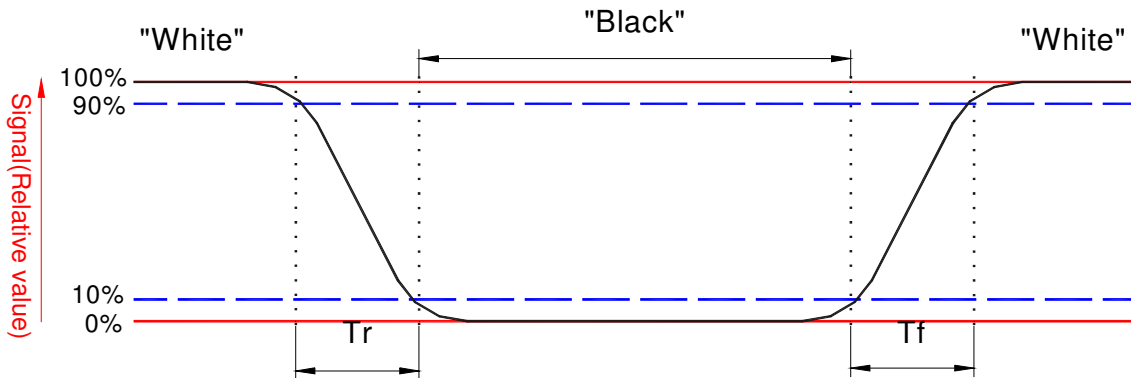

Note 4. Definition of contrast ratio:

ALL RIGHTS STRICTLY RESERVED. ANY PORTION OF THIS PAPER SHALL NOT BE REPRODUCED, COPIED, OR TRANSFORMED TO ANY OTHER FORMS WITHOUT PERMISSION FROM AU OPTRONICS CORP.

Contrast ratio is calculated with the following formula.

$$\text{Contrast ratio (CR)} = \frac{\text{Photo detector output when LCD is at "White" state}}{\text{Photo detector output when LCD is at "Black" state}}$$

Note 5. Definition of viewing angle, θ , Refer to figure as below.

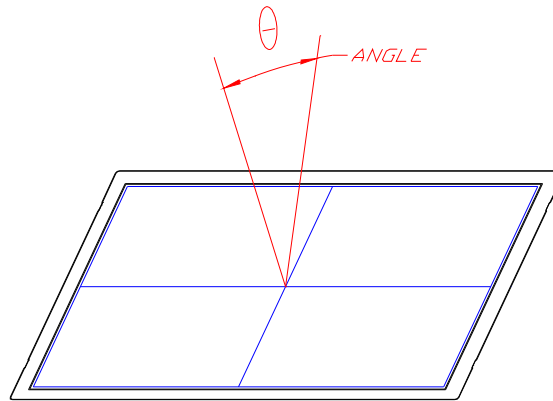

Note 6. Measured at the center area of the panel when all the input terminals of LCD panel are electrically opened.

J. Absolute Ratings of Ambient Environment

No.	Test items	Conditions	Remark
1	High Temperature Storage	Ta= 60□ 240Hrs	
2	Low Temperature Storage	Ta= -20□ 240Hrs	
3	High Ttemperature Operation	Ta= 50□ 240Hrs	
4	Low Temperature Operation	Ta= 0□ 240Hrs	
5	High Temperature & High Humidity	Ta= 50□. 80% RH 240Hrs	Operation
6	Heat Shock	-10□~60□, 50 cycle, 2Hrs/cycle	Non-operation
7	ESD (ElectroStatic Discharge)	Contact Discharge: ± 4KV, 150pF(330Ω) 1sec, 8 points, 25 times/ point.	Note 3
		Air Discharge: ± 8KV, 150pF(330Ω) 1sec 8 points, 25 times/ point.	
8	Vibration	Frequency range : 10 ~ 55Hz Stoke : 1.5mm Sweep :10~55~10Hz 2 hours for each direction of X,Y,Z Total 6 hours	Non-operation JIS C7021, A-10
9	Mechanical Shock	220G . 2ms, ±X,±Y,±Z 1 times for each direction	Non-operation JIS C7021, A-7 condition C
10	Vibration (With Carton)	Random vibration: 0.015G ² /Hz from 5~200Hz -6dB/Octave from 200~500Hz	IEC 68-34
11	Drop (With Carton)	Height: 60cm 1 corner, 3 edges, 6 surfaces	

Note 1: Ta: Ambient Temperature.

Note 2: In the standard conditions, there is not display function NG issue occurred. All the cosmetic specification is judged before the reliability stress.

Note 3: According to EN61000-4-2, ESD class B: Some performance degradation allowed. No data lost. Self-recoverable. No hardware failures.

K. Packing Form

