



Product Specification

AU OPTRONICS CORPORATION

(V) Preliminary Specifications

() Final Specifications

Module	" WXGA Color TFT-LCD with LED Backlight design
Model Name	B121EW09 V0
Note ()	LED Backlight with driving circuit design

Customer	Date
Checked & Approved by	Date
_____	_____
Note: This Specification is subject to change without notice.	

Approved by	Date
Prepared by	
_____	_____
_____	_____
NBBU Marketing Division / AU Optronics corporation	



Product Specification

AU OPTRONICS CORPORATION

Contents

1. Handling Precautions	4
2. General Description	5
2.1 General Specification.....	5
2.2 Optical Characteristics.....	6
3. Functional Block Diagram	11
4. Absolute Maximum Ratings.....	11
4. Absolute Maximum Ratings.....	12
4.1 Absolute Ratings of TFT LCD Module.....	12
4.2 Absolute Ratings of Backlight Unit.....	12
4.3 Absolute Ratings of Environment.....	12
5. Electrical characteristics	13
5.1 TFT LCD Module.....	13
5.2 Backlight Unit.....	15
6. Signal Characteristic	16
6.1 Pixel Format Image.....	16
6.2 The input data format.....	17
6.3 Signal Description/Pin Assignment.....	18
6.4 Interface Timing.....	21
6.5 LED Power Sequence.....	23
7. Connector Description	24
7.1 TFT LCD Module.....	24
8.8. LED Driving Specification	25
8.1 Connector Description.....	25
8.2 Pin Assignment.....	25
9. Reliability	26
10. Mechanical Characteristics	27
10.1 LCM Outline Dimension.....	27
10.2 Screw Hole Depth and Center Position.....	29
11. Shipping and Package	30
11.1 Shipping Label Format.....	30
11.2 Carton package.....	31
11.3 Shipping package of palletizing sequence.....	31
12. Appendix: EDID description	32



Product Specification

AU OPTRONICS CORPORATION

Record of Revision

Version and Date	Page	Old description	New Description	Remark
0.1 2008/01/10	All	First Edition for Customer		
0.2 2008/01/22	19	6.3 Signal Description/Pin Assignment 0.1 version	6.3 Signal Description/Pin Assignment 0.2 version	
0.3 2008/02/18	21	Clock frequency : 1. 68.9 MHz 2. Horizontal Section, Blanking: 128	Clock frequency : 1. 69.4 MHz 2. Horizontal Section, Blanking: 136	



1. Handling Precautions

- 1) Since front polarizer is easily damaged, pay attention not to scratch it.
- 2) Be sure to turn off power supply when inserting or disconnecting from input connector.
- 3) Wipe off water drop immediately. Long contact with water may cause discoloration or spots.
- 4) When the panel surface is soiled, wipe it with absorbent cotton or other soft cloth.
- 5) Since the panel is made of glass, it may break or crack if dropped or bumped on hard surface.
- 6) Since CMOS LSI is used in this module, take care of static electricity and insure human earth when handling.
- 7) Do not open nor modify the Module Assembly.
- 8) Do not press the reflector sheet at the back of the module to any directions.
- 9) At the insertion or removal of the Signal Interface Connector, be sure not to rotate nor tilt the Interface Connector of the TFT Module.
- 11) After installation of the TFT Module into an enclosure (Notebook PC Bezel, for example), do not twist nor bend the TFT Module even momentarily. At designing the enclosure, it should be taken into consideration that no bending/twisting forces are applied to the TFT Module from outside. Otherwise the TFT Module may be damaged.
- 12) Small amount of materials having no flammability grade is used in the LCD module. The LCD module should be supplied by power complied with requirements of Limited Power Source (IEC60950 or UL1950), or be applied exemption.
- 13) Disconnecting power supply before handling LCD modules, it can prevent electric shock, DO NOT TOUCH the electrode parts, cables, connectors and LED circuit part of TFT module that a LED light bar build in as a light source of back light unit. **It can prevent electrostatic breakdown.**



2. General Description

B121EW09 V0 is a Color Active Matrix Liquid Crystal Display composed of a TFT LCD panel, a driver circuit, and LED backlight system. The screen format is intended to support the WXGA (1280(H) x 800(V)) screen and 262k colors (RGB 6-bits data driver) with LED backlight driving circuit. All input signals are LVDS interface compatible.

B121EW09 V0 is designed for a display unit of notebook style personal computer and industrial machine.

2.1 General Specification

The following items are characteristics summary on the table at 25 °C condition:

Items	Unit	Specifications			
Screen Diagonal	[mm]	307.9 (W")			
Active Area	[mm]	261.12(H) X 163.2(V)			
Pixels H x V		1280x3(RGB) x 800			
Pixel Pitch	[mm]	0.204X0.204			
Pixel Arrangement		R.G.B. Vertical Stripe			
Display Mode		Normally White			
White Luminance (I _{LED} =20mA) Note: I _{LED} is LED current	[cd/m ²]	200 typ. (5 points average) 170 min. (5 points average) (Note1)			
Luminance Uniformity		1.25 max. (5 points)			
Contrast Ratio		400 typ			
Response Time	[ms]	16 typ / 25 Max			
Nominal Input Voltage VDD	[Volt]	+3.3 typ.			
Power Consumption	[Watt]	4.5 max. (Include Logic and Black Light power)			
Weight	[Grams]	270 max.			
Physical Size	[mm]		L	W	T
		Max	276.3	178.6	5.2
		Typical	275.8	178	-
		Min	275.3	-	-
Electrical Interface		1 channel LVDS			
Surface Treatment		Glare, Hardness 3H,			



Product Specification

AU OPTRONICS CORPORATION

Support Color		262K colors (RGB 6-bit)
Temperature Range Operating Storage (Non-Operating)	[°C] [°C]	0 to +50 -20 to +65
RoHS Compliance		RoHS Compliance

2.2 Optical Characteristics

The optical characteristics are measured under stable conditions at 25°C (Room Temperature) :

Item	Unit	Conditions	Min.	Typ.	Max.	Note
White Luminance I _{LED} =20mA	[cd/m ²]	5 points average	170	200	-	1, 4, 5.
Viewing Angle	[degree]	Horizontal (Right) CR = 10 (Left)	40	45	-	8
	[degree]		40	45	-	
	[degree] [degree]	Vertical (Upper) CR = 10 (Lower)	10 30	15 35	- -	
Luminance Uniformity		5 Points	-	-	1.25	1
Luminance Uniformity		13 Points	-	-	1.50	2
CR: Contrast Ratio		DCR:Off	300	400	-	6
Cross talk	%				4	7
Response Time	[msec]	Rising	-	TBD	-	8
	[msec]	Falling	-	TBD	-	
	[msec]	Rising + Falling	-	16	25	
Chromaticity of color Coordinates (CIE 1931)		Red x		TBD		2,8
		Red y		TBD		
		Green x		TBD		
		Green y		TBD		
		Blue x		TBD		
		Blue y		TBD		
		White x	0.263	0.313	0.363	
	White y	0.279	0.329	0.379		

Note 1: 5 points position (Ref: Active area)

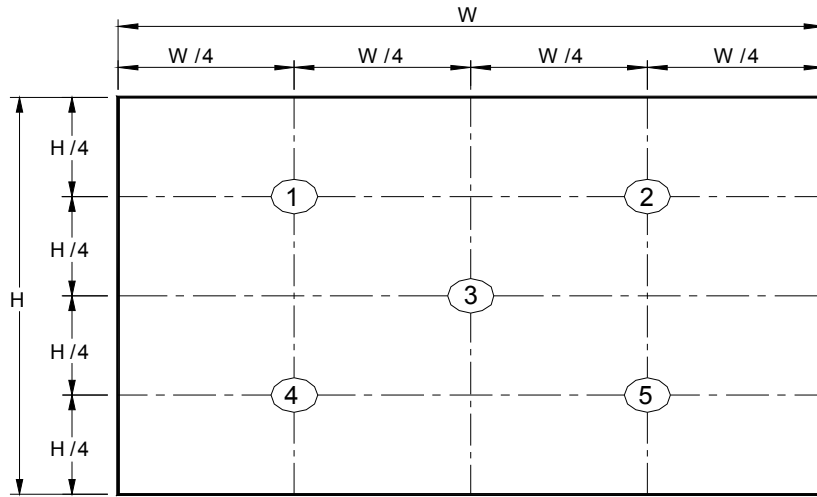

Note 2: 13 points position (Ref: Active area)

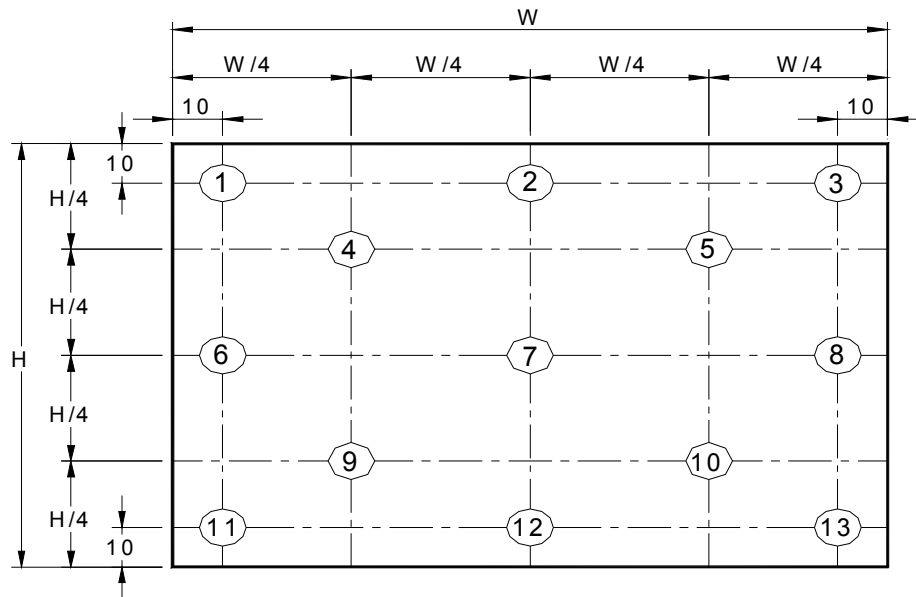

Note 3: The luminance uniformity of 5 or 13 points is defined by dividing the maximum luminance values by the minimum test point luminance

$$\delta_{W5} = \frac{\text{Maximum Brightness of five points}}{\text{Minimum Brightness of five points}}$$

$$\delta_{W13} = \frac{\text{Maximum Brightness of thirteen points}}{\text{Minimum Brightness of thirteen points}}$$

Note 4: Measurement method

The LCD module should be stabilized at given temperature for 30 minutes to avoid abrupt temperature change during measuring. In order to stabilize the luminance, the measurement should be executed after lighting Backlight for 30 minutes in a stable, windless and dark room.

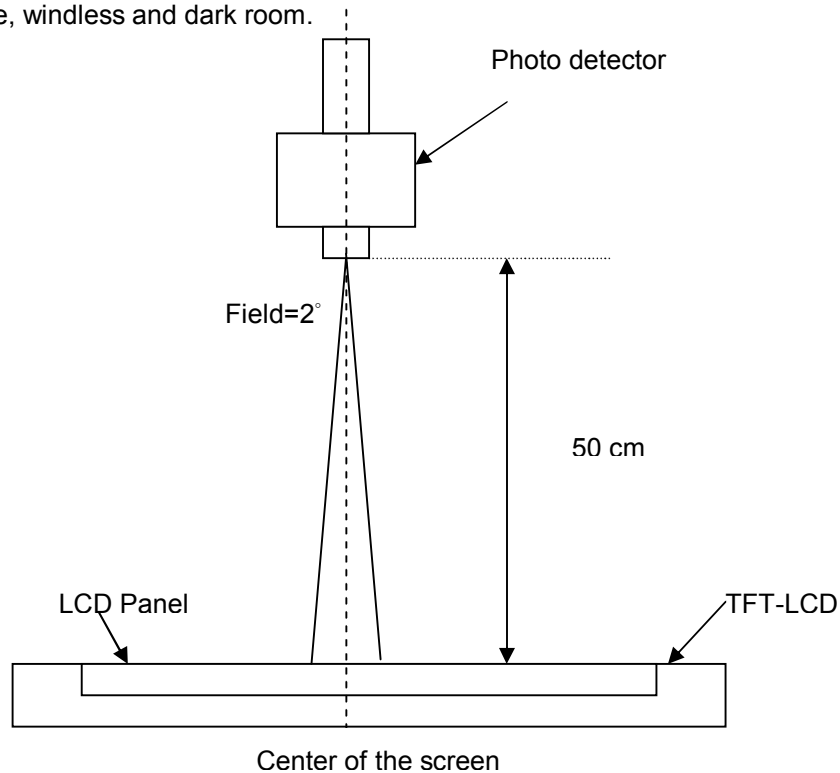

Note 5 : Definition of Average Luminance of White (Y_L):

Measure the luminance of gray level 63 at 5 points , $Y_L = [L (1)+ L (2)+ L (3)+ L (4)+ L (5)] / 5$

$L (x)$ is corresponding to the luminance of the point X at Figure in Note (1).

Note 6 : Definition of contrast ratio:

Contrast ratio is calculated with the following formula.

$$\text{Contrast ratio (CR)} = \frac{\text{Brightness on the "white" state}}{\text{Brightness on the "black" state}}$$

Note 7 : Definition of Cross Talk (CT)

$$CT = |Y_B - Y_A| / Y_A \times 100 (\%)$$

Where

Y_A = Luminance of measured location without gray level 0 pattern (cd/m^2)

Y_B = Luminance of measured location with gray level 0 pattern (cd/m^2)

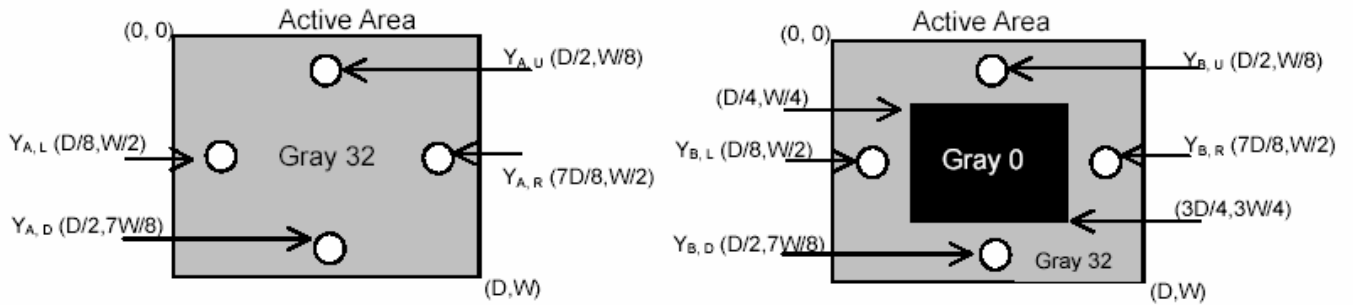

Note 8: Definition of response time:

The output signals of BM-7 or equivalent are measured when the input signals are changed from "Black" to "White" (falling time) and from "White" to "Black" (rising time), respectively. The response time interval between the 10% and 90% of amplitudes. Refer to figure as below.

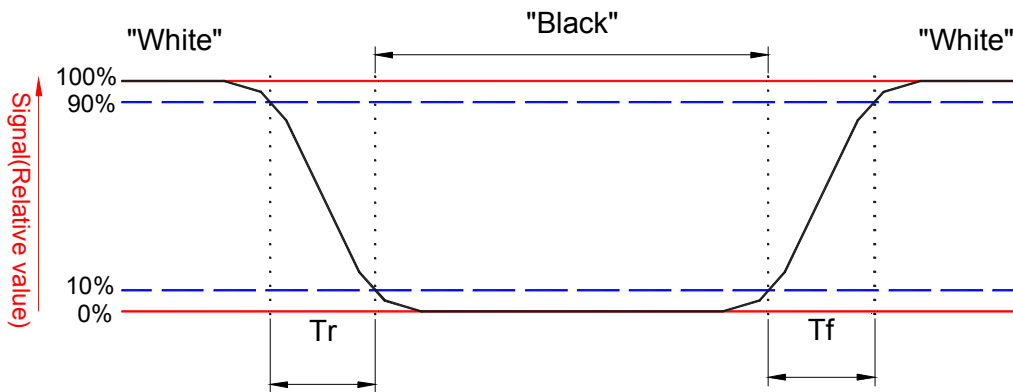

Note 8. Definition of viewing angle

Viewing angle is the measurement of contrast ratio ≥ 10 , at the screen center, over a 180° horizontal and 180° vertical range (off-normal viewing angles). The 180° viewing angle range is broken down as follows; 90° (θ) horizontal left and right and 90° (ϕ) vertical, high (up) and low (down). The measurement direction is typically perpendicular to the display surface with the screen rotated about its center to develop the desired measurement viewing angle.

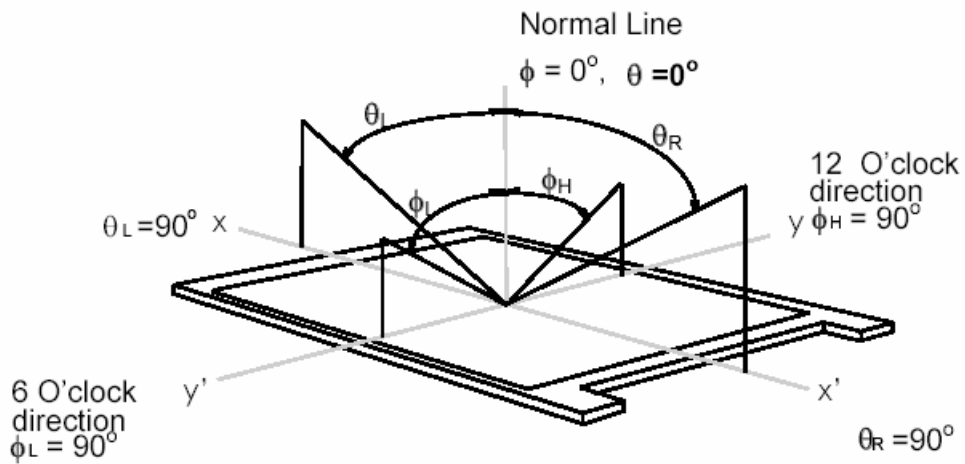

3. Functional Block Diagram

The following diagram shows the functional block of the 12.1 inches wide Color TFT/LCD 40 Pin (One ch/connector Module):

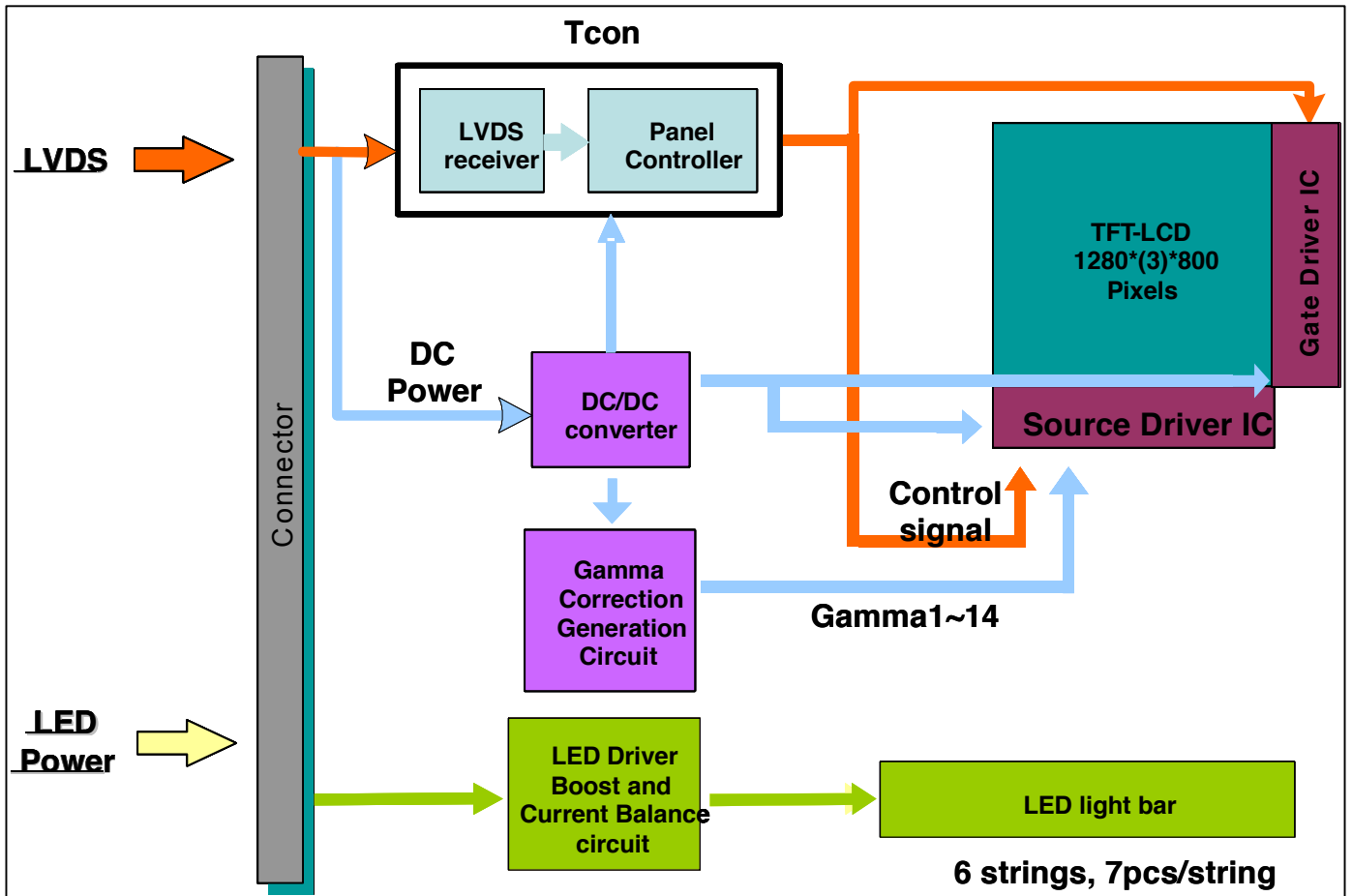

4. Absolute Maximum Ratings

An absolute maximum rating of the module is as following:

4.1 Absolute Ratings of TFT LCD Module

Item	Symbol	Min	Max	Unit	Conditions
Logic/LCD Drive	V _{in}	-0.3	+4.0	[Volt]	Note 1,2

4.2 Absolute Ratings of Backlight Unit

Item	Symbol	Min	Max	Unit	Conditions
LED Driving Voltage	V _{LED}	-	36 (Row Output)	[Volt]	Note 1,2,3
LED Driving Current	I _{LED}	-	30 (Row Output)	[mA] rms	Note 1,2,3

4.3 Absolute Ratings of Environment

Item	Symbol	Min	Max	Unit	Conditions
Operating Temperature	TOP	0	+50	[°C]	Note 4
Operation Humidity	HOP	8	95	[%RH]	Note 4
Storage Temperature	TST	-20	+65	[°C]	Note 4
Storage Humidity	HST	5	95	[%RH]	Note 4

Note 1: At Ta (25°C)

Note 2: Permanent damage to the device may occur if exceed maximum values

Note 3: LED specification refer to section 5.2

Note 4: For quality performance, please refer to AUO IIS (Incoming Inspection Standard).

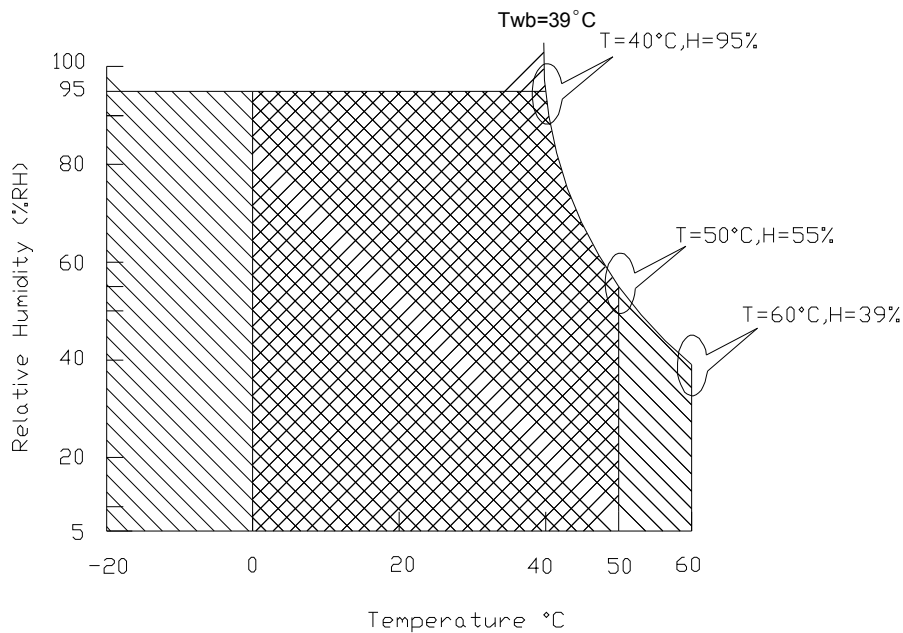

Operating Range

Storage Range +

5. Electrical characteristics

5.1 TFT LCD Module

5.1.1 Power Specification

Input power specifications are as follows;

Symble	Parameter	Min	Typ	Max	Units	Note
VDD	Logic/LCD Drive Voltage	3.0	3.3	3.6	[Volt]	
PDD	VDD Power	-	-	TBD	[Watt]	Note 1/2
IDD	IDD Current	-	TBD	TBD	[mA]	Note 1/2
IRush	Inrush Current	-	-	2000	[mA]	Note 3
VDDrp	Allowable Logic/LCD Drive Ripple Voltage	-	-	TBD	[mV] p-p	

Note 1 : Maximum Measurement Condition : Black Pattern

Note 2 : Typical Measurement Condition: Mosaic Pattern

Note 3 : Measure Condition

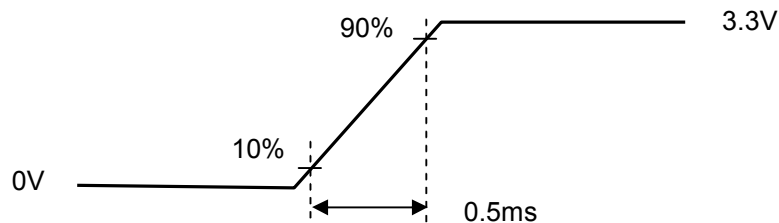
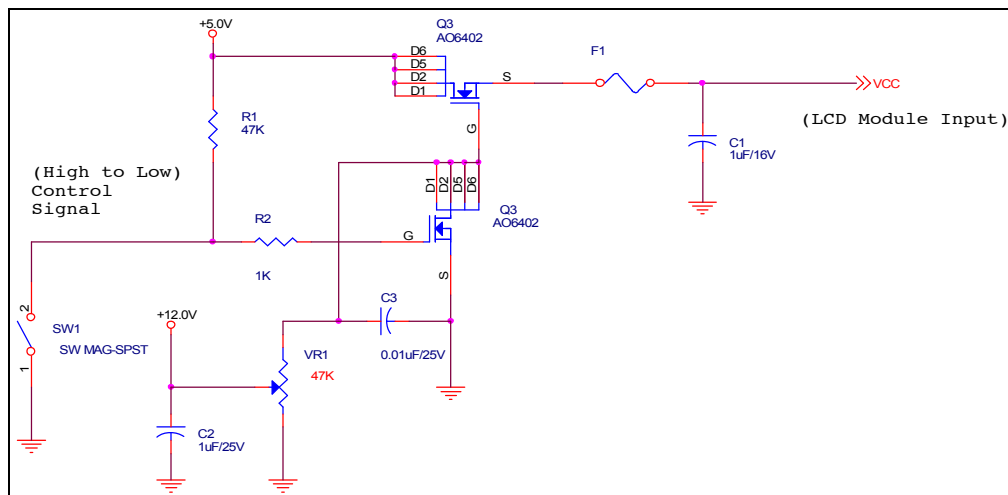

Vin rising time

5.1.2 Signal Electrical Characteristics

Input signals shall be low or High-impedance state when VDD is off.

It is recommended to refer the specifications of THC63LVDF84A (Thine Electronics Inc.) in detail.

Signal electrical characteristics are as follows;

Parameter	Condition	Min	Max	Unit
Vth	Differential Input High Threshold (Vcm=+1.2V)	-	100	[mV]
Vtl	Differential Input Low Threshold (Vcm=+1.2V)	-100	-	[mV]
Vcm	Differential Input Common Mode Voltage	1.125	1.375	[V]

Note: LVDS Signal Waveform

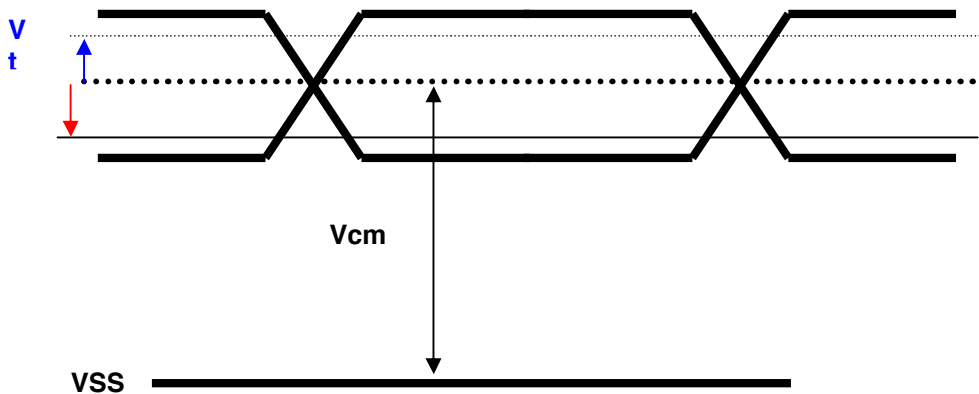



Product Specification

AU OPTRONICS CORPORATION

5.2 Backlight Unit

LED Parameter guideline for LED driving selection (Ref. Remark 1)

Parameter	Symbol	Min	Typ	Max	Units	Condition
LED Forward Voltage	V_F	2.95	3.15	3.35	[Volt]	(Ta=25°C)
LED Forward Current	I_F		20	30	[mA]	(Ta=25°C)
LED Power consumption	P_{LED}		3.78		[Watt]	(Ta=25°C) Note 1
LED Life-Time	N/A	10,000	-	-	Hour	(Ta=25°C) $I_F=20$ mA Note 2

Note 1: Calculator value for reference $I_F = P$

Note 2: The LED life-time define as the estimated time to 50% degradation of initial luminous.

6.2 The input data format

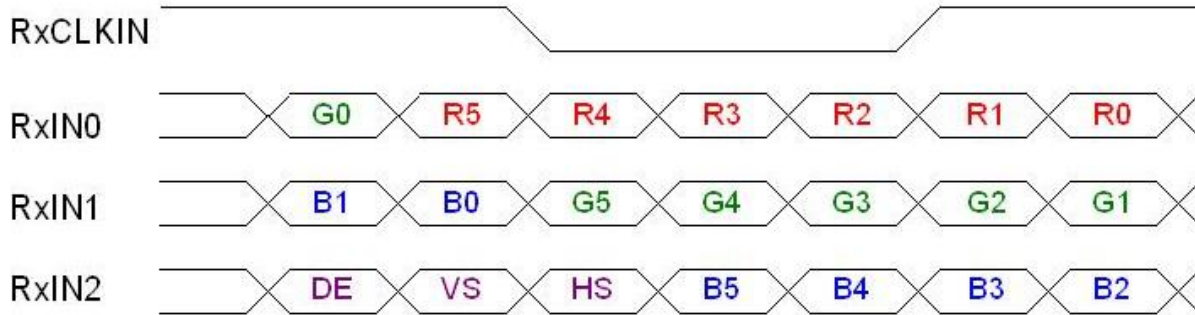

Signal Name	Description	
R5 R4 R3 R2 R1 R0	Red Data 5 (MSB) Red Data 4 Red Data 3 Red Data 2 Red Data 1 Red Data 0 (LSB)	Red-pixel Data Each red pixel's brightness data consists of these 6 bits pixel data.
	Red-pixel Data	
G5 G4 G3 G2 G1 G0	Green Data 5 (MSB) Green Data 4 Green Data 3 Green Data 2 Green Data 1 Green Data 0 (LSB)	Green-pixel Data Each green pixel's brightness data consists of these 6 bits pixel data.
	Green-pixel Data	
B5 B4 B3 B2 B1 B0	Blue Data 5 (MSB) Blue Data 4 Blue Data 3 Blue Data 2 Blue Data 1 Blue Data 0 (LSB)	Blue-pixel Data Each blue pixel's brightness data consists of these 6 bits pixel data.
	Blue-pixel Data	
RxCLKIN	Data Clock	The typical frequency is 68.9 MHz. The signal is used to strobe the pixel data and DE signals. All pixel data shall be valid at the falling edge when the DE signal is high.
DE	Display Timing	This signal is strobed at the falling edge of RxCLKIN. When the signal is high, the pixel data shall be valid to be displayed.
VS	Vertical Sync	The signal is synchronized to RxCLKIN .
HS	Horizontal Sync	The signal is synchronized to RxCLKIN .

Note: Output signals from any system shall be low or High-impedance state when VDD is off.



6.3 Signal Description/Pin Assignment

LVDS is a differential signal technology for LCD interface and high speed data transfer device.

PIN#	Symbol	Function
1	GND	Ground
2	VDD	+3.3V Power Supply
3	VDD	+3.3V Power Supply
4	V _{EDID}	+3.3V EDID Power
5	NC	No Connection (Reserve for AUO test)
6	CLK _{EDID}	EDID Clock Input
7	DATA _{EDID}	EDID Data Input
8	RxIN0-	-LVDS differential data input (R0-R5, G0)
9	RxIN0+	+LVDS differential data input (R0-R5, G0)
10	GND	Ground
11	RxIN1-	-LVDS differential data input(G1-G5, B0-B1)
12	RxIN1+	+LVDS differential data input(G1-G5, B0-B1)
13	GND	Ground
14	RxIN2-	-LVDS differential data input(B2-B5, HS, VS, DE)
15	RxIN2+	+LVDS differential data input(B2-B5, HS, VS, DE)
16	GND	Ground
17	RxCLKIN-	-LVDS differential clock input
18	RxCLKIN+	+LVDS differential clock input
19	GND	Ground
20	NC	No Connection (Reserve for AUO test)
21	NC	No Connection (Reserve for AUO test)
22	GND	Ground
23	NC	No Connection (Reserve for AUO test)
24	NC	No Connection (Reserve for AUO test)
25	GND	Ground
26	NC	No Connection (Reserve for AUO test)
27	NC	No Connection (Reserve for AUO test)
28	NC	No Connection (Reserve for AUO test)
29	NC	No Connection (Reserve for AUO test)
30	NC	No Connection (Reserve for AUO test)
31	VLED_GND	LED Ground
32	VLED_GND	LED Ground
33	VLED_GND	LED Ground
34	VLED	LED Power Supply 7V-20V
35	VLED	LED Power Supply 7V-20V
36	VLED	LED Power Supply 7V-20V
37	VLED	LED Power Supply 7V-20V
38	S_PWMIN	System PWM signal Input
39	LED_EN	LED enable pin (+3V input)
40	NC	No Connect (Reserve for AUO test)

Note1: Start from right side

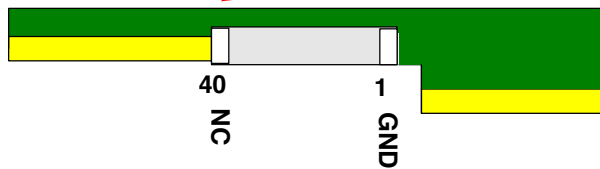
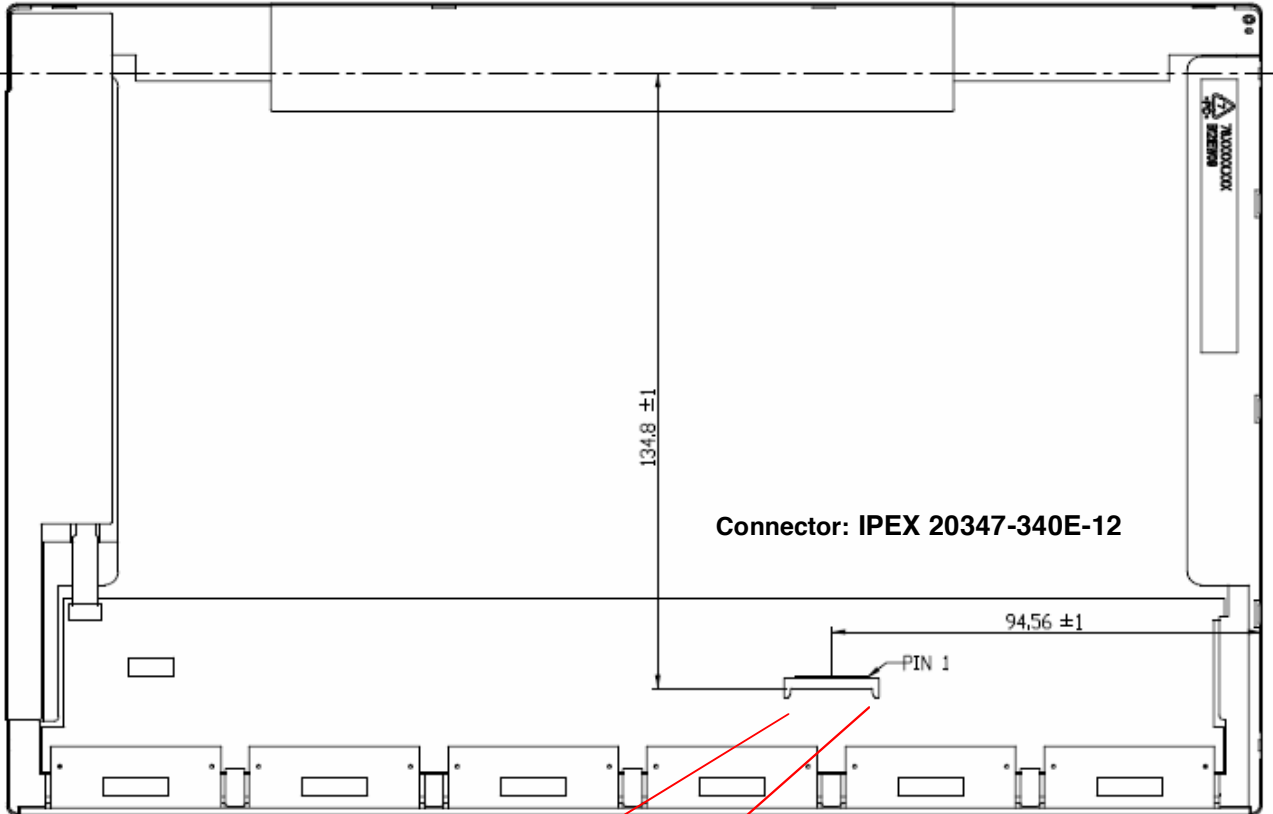

Connector: IPEX 20347-340E-12

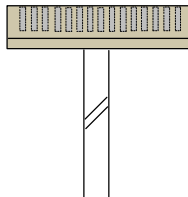

Note2: Input signals shall be low or High-impedance state when VDD is off.

internal circuit of LVDS inputs are as following.

The module uses a 100ohm resistor between positive and negative data lines of each receiver input

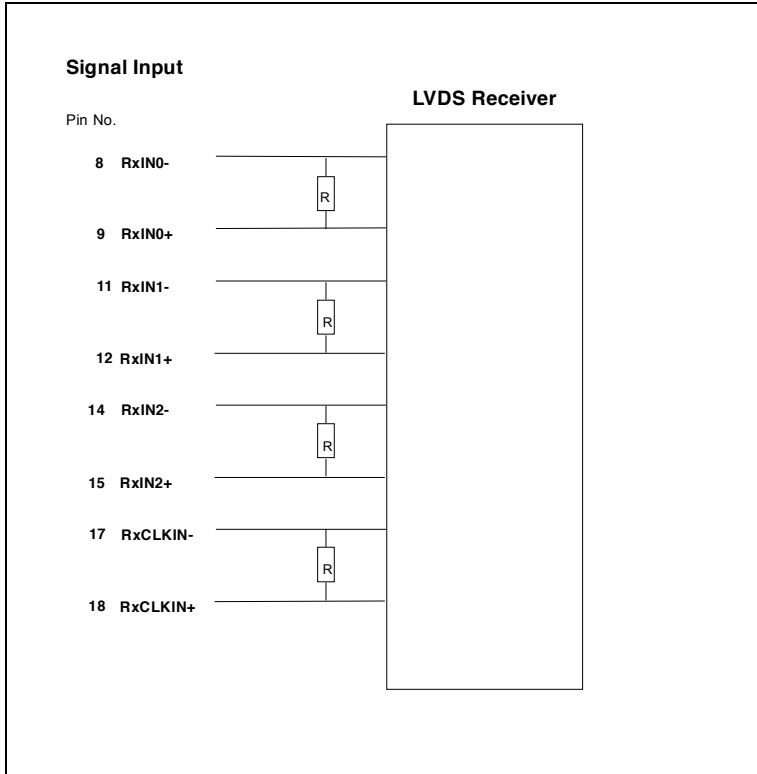



6.4 Interface Timing

6.4.1 Timing Characteristics

Basically, interface timings should match the 1280x800 /60Hz manufacturing guide line timing.

Parameter		Symbol	Min.	Typ.	Max.	Unit
Frame Rate		-	-	60	-	Hz
Clock frequency		$1/T_{\text{Clock}}$	50-	69.3	80-	MHz
Vertical Section	Period	T_V	803	816	1023	T_{Line}
	Active	T_{VD}	800	800	800	
	Blanking	T_{VB}	3	16	223	
Horizontal Section	Period	T_H	1303	1408	2047	T_{Clock}
	Active	T_{HD}	1280	1280	1280	
	Blanking	T_{HB}	23	136	767	

Note : DE mode only

6.4.2 Timing diagram

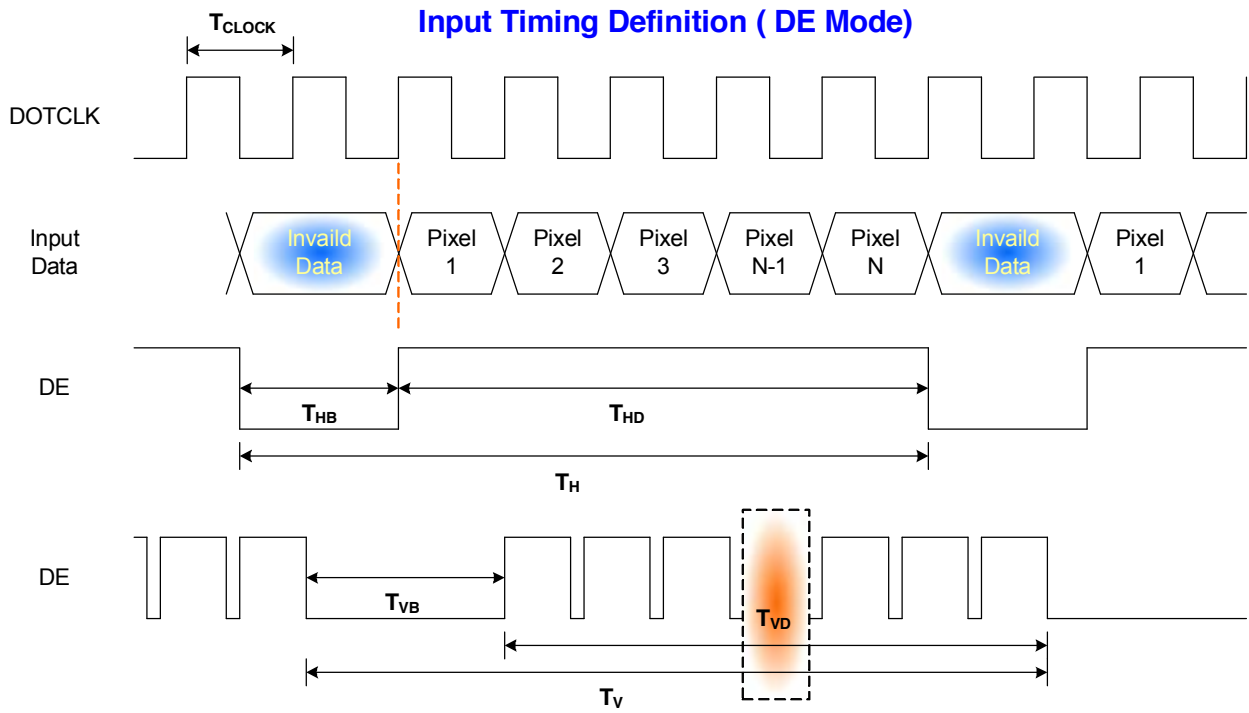

6.5 LED Power Sequence

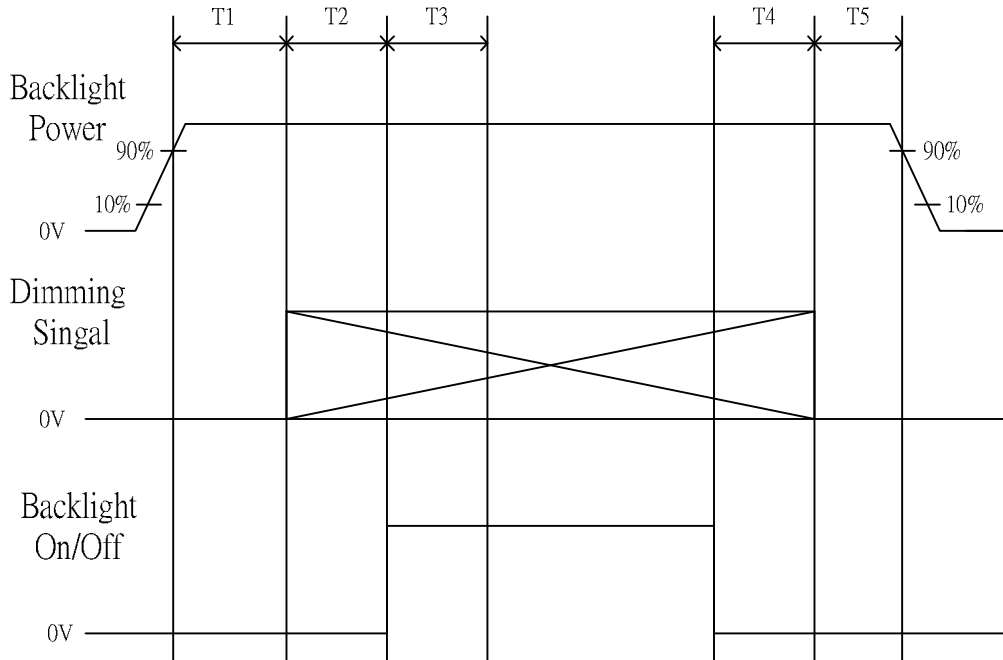

Symbol	Values			Unit
	Min	Typ	Max	
T1	10	---	---	ms
T2	10	---	---	ms
T3	50	---	---	ms
T4	0	---	---	ms
T5	10	---	---	ms

Note: The duty of LED dimming signal should be more than 20% in T2 and T3.



7. Connector Description

Physical interface is described as for the connector on module.

These connectors are capable of accommodating the following signals and will be following components.

7.1 TFT LCD Module

Connector Name / Designation	For Signal Connector
Manufacturer	IPEX or compatible
Type / Part Number	IPEX 20347-340E-12 or compatible
Mating Housing/Part Number	IPEX 20347-340E-12 or compatible



8. 8. LED Driving Specification

8.1 Connector Description

It is a integrative interface and comibe into LVDS connector. The type and mating refer to section 7.

8.2 Pin Assignment

PIN#	Signal Name	Description
31	VLED_GND	LED Ground
32	VLED_GND	LED Ground
33	VLED_GND	LED Ground
34	VLED	LED Power Supply 7V-20V
35	VLED	LED Power Supply 7V-20V
36	VLED	LED Power Supply 7V-20V
37	VLED	LED Power Supply 7V-20V
38	S_PWMIN	System PWM signal Input
39	LED_EN	LED enable pin (+3V input)
40	NC	No Connect (Reserve for AUO)



9. Reliability

Items	Required Condition	Note
Temperature Humidity Bias	Ta= 40°C , 90%RH, 300h	
High Temperature Operation	Ta= 50°C , Dry, 300h	
Low Temperature Operation	Ta= 0°C , 300h	
High Temperature Storage	Ta= 60°C , 300h	
Low Temperature Storage	Ta= -20°C , 300h	
Thermal Shock Test	Ta=-20°C to 60°C , Duration at 30 min, 100 cycles	
ESD	Contact : ±8 KV Air : ±15 KV	Note 1

Note1: According to EN 61000-4-2 , ESD class B: Some performance degradation allowed. No data lost
. Self-recoverable. No hardware failures.

Remark: MTBF (Excluding the LED): 30,000 hours with a confidence level 90%



Product Specification

AU OPTRONICS CORPORATION

10. Mechanical Characteristics

10.1 LCM Outline Dimension

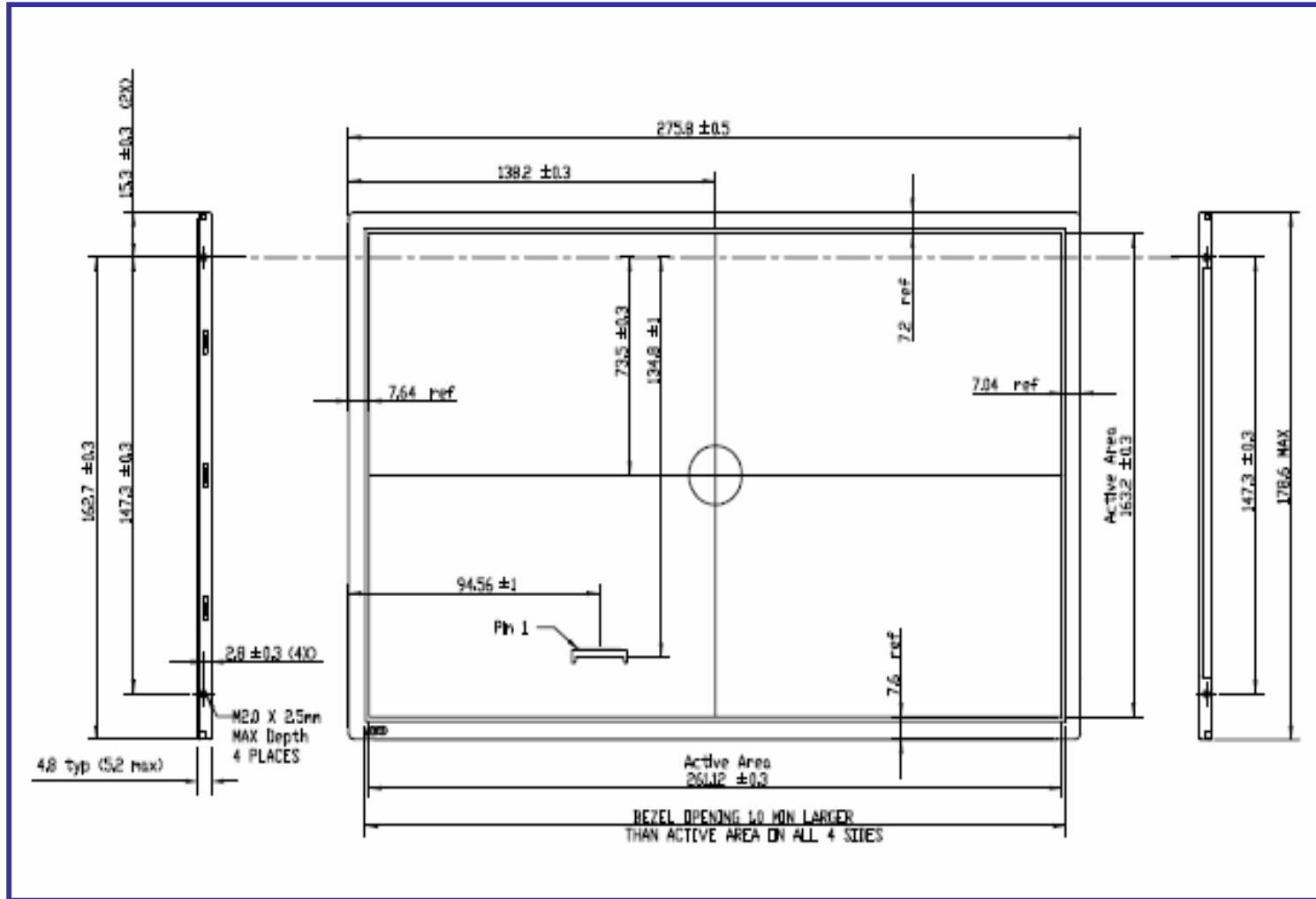



Product Specification

AU OPTRONICS CORPORATION

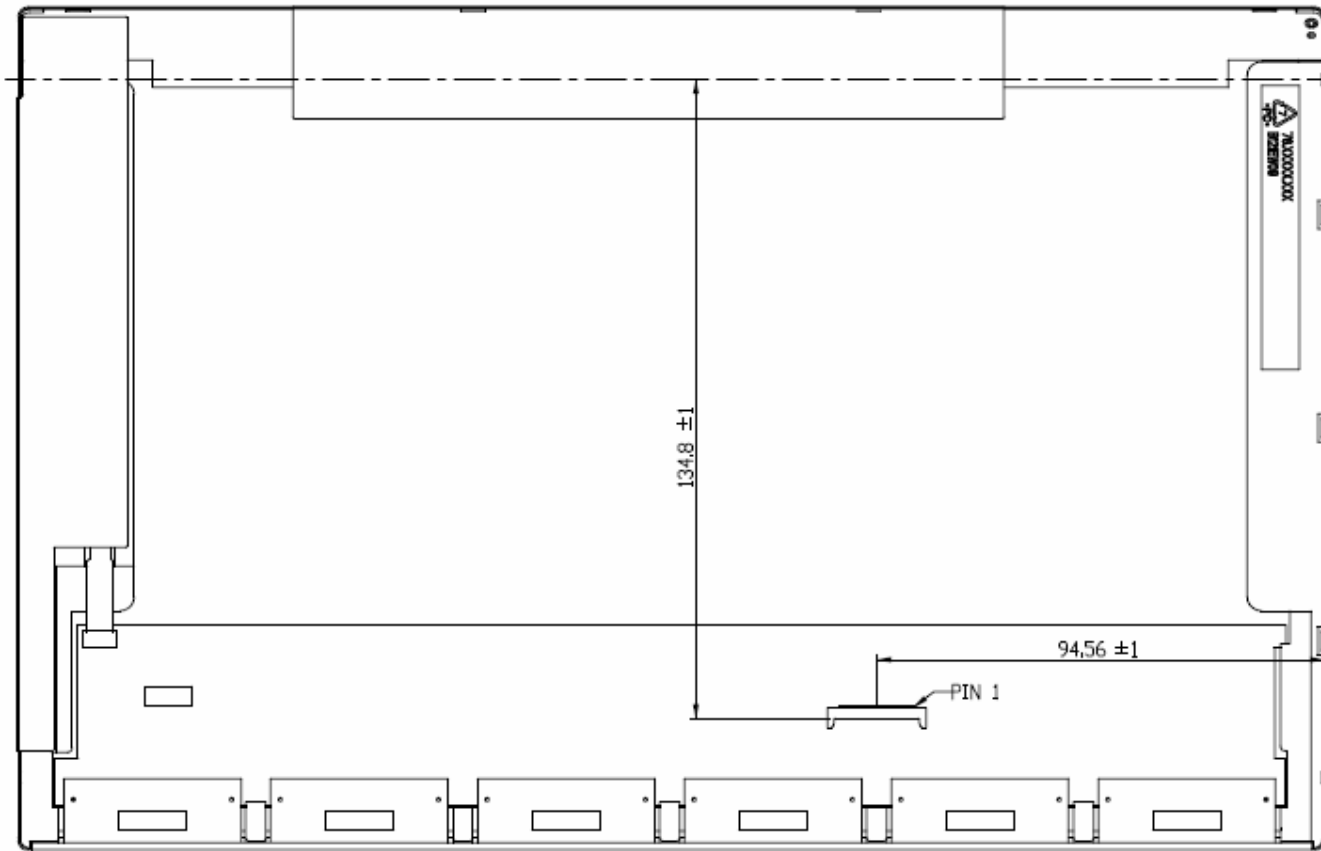

10.2 Screw Hole Depth and Center Position

Screw hole minimum depth, from side surface = 2.1 mm (See drawing)

Screw hole center location, from front surface = 2.8 ± 0.2 mm (See drawing)

Screw Torque: Maximum 2.5 kgf-cm

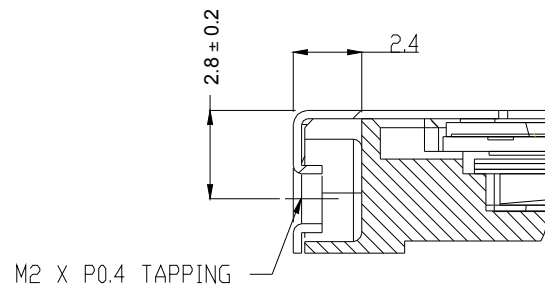



11. Shipping and Package

11.1 Shipping Label Format

 XXXXXXXXXXXX-XXXXX	Manufactured 0805 Model No: B121EW09 V0 AU Optronics MADE IN CHINA (S1)	0A0XG E204356	 
HW: 0A FW:1			

11.2 Carton package

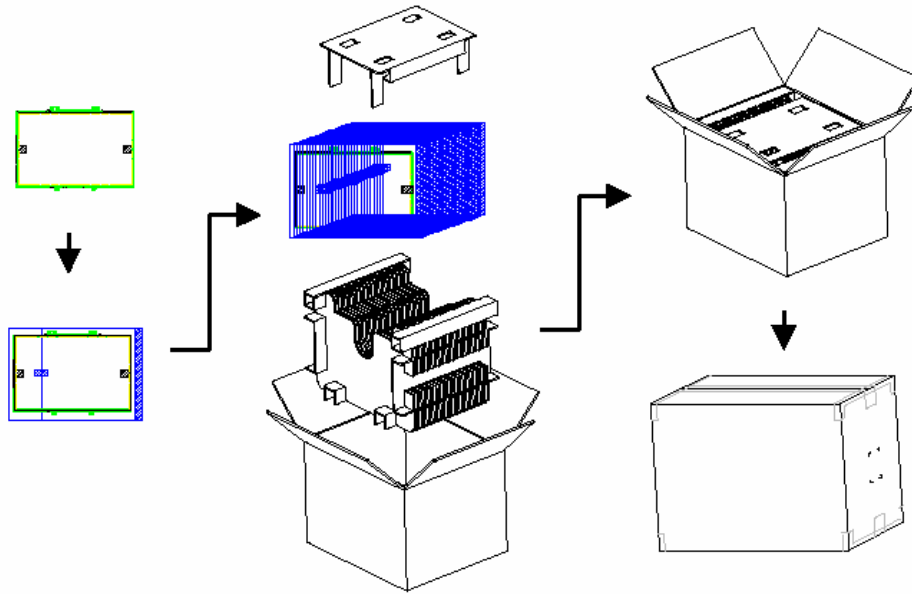

11.3 Shipping package of palletizing sequence

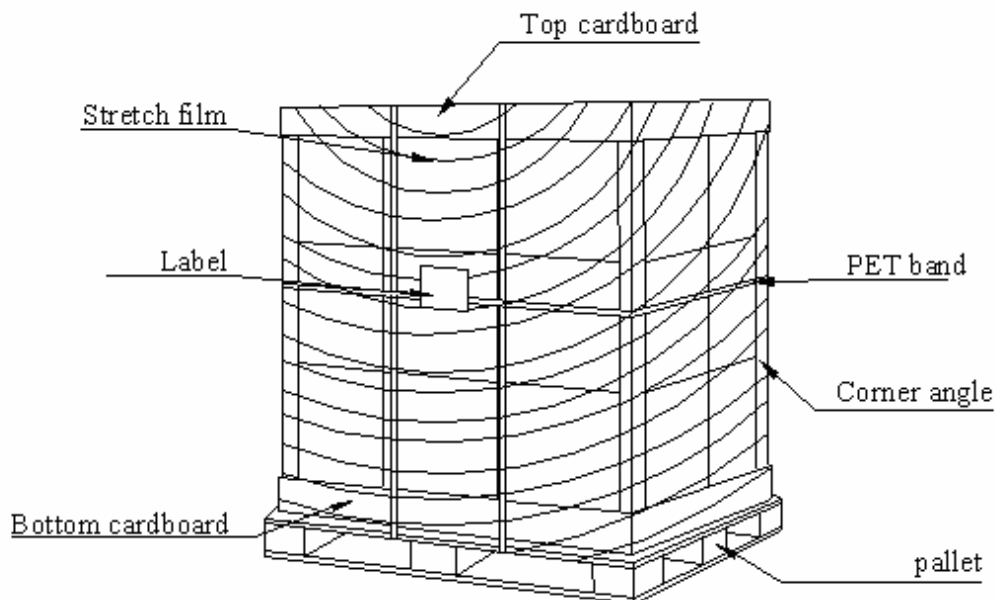



12. Appendix: EDID description