



# Product Specification

AU OPTRONICS CORPORATION

( ) Preliminary Specifications

( V ) Final Specifications

<b>Module</b>	<b>14.0" (13.98") HD+ 16:9 Color TFT-LCD with LED Backlight design</b>
<b>Model Name</b>	<b>B140RW02 V2 (H/W:0A)</b>
<b>Note</b> (  )	<b><i>LED Backlight with driving circuit design</i></b>

<b>Customer</b>	<b>Date</b>
<b>Checked &amp; Approved by</b>	<b>Date</b>
Note: This Specification is subject to change without notice.	

<b>Approved by</b>	<b>Date</b>
<u>Bonnie Chen</u>	<u>10/04/2010</u>
<b>Prepared by</b>	<b>Date</b>
<u>HsinYin Yu</u>	<u>10/04/2010</u>
<b>NBBU Marketing Division AU Optronics corporation</b>	



**Contents**

**1. Handling Precautions ..... 4**

**2. General Description ..... 5**

2.1 General Specification ..... 5

2.2 Optical Characteristics ..... 6

**3. Functional Block Diagram ..... 11**

**4. Absolute Maximum Ratings ..... 12**

4.1 Absolute Ratings of TFT LCD Module ..... 12

4.2 Absolute Ratings of Environment ..... 12

**5. Electrical Characteristics ..... 13**

5.1 TFT LCD Module ..... 13

5.2 Backlight Unit ..... 15

**6. Signal Interface Characteristic ..... 16**

6.1 Pixel Format Image ..... 16

6.2 The Input Data Format ..... 17

6.3 Integration Interface Requirement ..... 19

6.4 Interface Timing ..... 21

**7. Panel Reliability Test ..... 24**

7.1 Vibration Test ..... 24

7.2 Shock Test ..... 24

7.3 Reliability Test ..... 24

**8. Mechanical Characteristics ..... 25**

8.1 LCM Outline Dimension ..... 25

**9. Shipping and Package ..... 27**

9.1 Shipping /Carton Label Format ..... 27

9.2 Carton Package ..... 28

9.3 Shipping Package of Palletizing Sequence ..... 28

**10. Appendix: EDID Description ..... 29**



# Product Specification

AU OPTRONICS CORPORATION

## Record of Revision

Version and Date	Page	Old description	New Description	Remark
0.1 2010/07/09	All	First Edition for Customer		
0.2 2010/09/17	21	Old clock frequency	New colck frequency	
	26	Old outline drawing	Update outline drawing.	
	27	Old label information.	New label information.	
	29-31	EDID TBD	EDID information.	
1.0 2010/10/04	All	Preliminary SPEC	Final SPEC	
	29-31	Old EDID information	New EDID information	

## 1. Handling Precautions

- 1) Since front polarizer is easily damaged, pay attention not to scratch it.
- 2) Be sure to turn off power supply when inserting or disconnecting from input connector.
- 3) Wipe off water drop immediately. Long contact with water may cause discoloration or spots.
- 4) When the panel surface is soiled, wipe it with absorbent cotton or other soft cloth.
- 5) Since the panel is made of glass, it may break or crack if dropped or bumped on hard surface.
- 6) Since CMOS LSI is used in this module, take care of static electricity and insure human earth when handling.
- 7) Do not open nor modify the Module Assembly.
- 8) Do not press the reflector sheet at the back of the module to any directions.
- 9) At the insertion or removal of the Signal Interface Connector, be sure not to rotate nor tilt the Interface Connector of the TFT Module.
- 11) After installation of the TFT Module into an enclosure (Notebook PC Bezel, for example), do not twist nor bend the TFT Module even momentary. At designing the enclosure, it should be taken into consideration that no bending/twisting forces are applied to the TFT Module from outside. Otherwise the TFT Module may be damaged.
- 12) Small amount of materials having no flammability grade is used in the LCD module. The LCD module should be supplied by power complied with requirements of Limited Power Source (IEC60950 or UL1950), or be applied exemption.
- 13) Disconnecting power supply before handling LCD modules, it can prevent electric shock, DO NOT TOUCH the electrode parts, cables, connectors and LED circuit part of TFT module that a LED light bar build in as a light source of back light unit. It can prevent electrostatic breakdown.



## 2. General Description

B140RW02 V2 is a Color Active Matrix Liquid Crystal Display composed of a TFT LCD panel, a driver circuit, and LED backlight system. The screen format is intended to support the 16:9 HD, 1600(H) x900(V) screen and 262k colors (RGB 6-bits data driver) with LED backlight driving circuit. All input signals are LVDS interface compatible.

B140RW02 V2 is designed for a display unit of notebook style personal computer and industrial machine.

### 2.1 General Specification

The following items are characteristics summary on the table at 25 °C condition:

Items	Unit	Specifications			
Screen Diagonal	[mm]	354.95			
Active Area	[mm]	309.60 X 174.15			
Pixels H x V		1600x3(RGB) x 900			
Pixel Pitch	[mm]	0.1935X0.1935			
Pixel Format		R.G.B. Vertical Stripe			
Display Mode		Normally White			
White Luminance (ILED=20mA) (Note: ILED is LED current)	[cd/m <sup>2</sup> ]	200 typ. (5 points average)			
Luminance Uniformity		1.25 max. (5 points)			
Contrast Ratio		400(typ)			
Response Time	[ms]	8 typ / 16 Max			
Nominal Input Voltage VDD	[Volt]	+3.3 typ.			
Power Consumption	[Watt]	4.0 max. (Include Logic and Blu power)			
Weight	[Grams]	325 max.			
Physical Size <b>Include bracket</b>	[mm]		Min.	Typ.	Max.
		Length			320.9
		Width			205.6
		Thickness			3.6
Electrical Interface		2 channel LVDS			
Glass Thickness	[mm]	0.5			
Surface Treatment		Anti-Glare, Hardness 3H,			
Support Color		262K colors ( RGB 6-bit )			



# Product Specification

AU OPTRONICS CORPORATION

Temperature Range Operating Storage (Non-Operating)	[°C] [°C]	0 to +50 -20 to +60
RoHS Compliance		RoHS Compliance

## 2.2 Optical Characteristics

The optical characteristics are measured under stable conditions at 25°C (Room Temperature) :

Item	Symbol	Conditions	Min.	Typ.	Max.	Unit	Note	
<b>White Luminance</b> I <sub>LED</sub> =20mA		<b>5 points average</b>	<b>170</b>	<b>200</b>	<b>-</b>	cd/m <sup>2</sup>	1, 4, 5.	
<b>Viewing Angle</b>	$\theta_R$ $\theta_L$	<b>Horizontal (Right)</b> <b>CR = 10 (Left)</b>	<b>40</b> <b>40</b>	<b>45</b> <b>45</b>	<b>-</b> <b>-</b>	degree	4, 9	
	$\psi_H$ $\psi_L$	<b>Vertical (Upper)</b> <b>CR = 10 (Lower)</b>	<b>10</b> <b>30</b>	<b>15</b> <b>35</b>	<b>-</b> <b>-</b>			
<b>Luminance Uniformity</b>	$\delta_{5P}$	<b>5 Points</b>	<b>-</b>	<b>-</b>	<b>1.25</b>		1, 3, 4	
<b>Luminance Uniformity</b>	$\delta_{13P}$	<b>13 Points</b>	<b>-</b>	<b>-</b>	<b>1.50</b>		2, 3, 4	
<b>Contrast Ratio</b>	<b>CR</b>		<b>300</b>	<b>400</b>	<b>-</b>		4, 6	
<b>Cross talk</b>	%				<b>4</b>		4, 7	
<b>Response Time</b>	$T_r$	<b>Rising</b>	<b>-</b>			msec	4, 8	
	$T_f$	<b>Falling</b>	<b>-</b>					
	$T_{RT}$	<b>Rising + Falling</b>	<b>-</b>	<b>8</b>	<b>16</b>			
<b>Color / Chromaticity Coordinates</b>	<b>Red</b>	<b>R<sub>x</sub></b>	<b>CIE 1931</b>	<b>0.580</b>	<b>0.610</b>	<b>0.640</b>	-	4
		<b>R<sub>y</sub></b>		<b>0.320</b>	<b>0.350</b>	<b>0.380</b>		
	<b>Green</b>	<b>G<sub>x</sub></b>		<b>0.290</b>	<b>0.320</b>	<b>0.350</b>		
		<b>G<sub>y</sub></b>		<b>0.530</b>	<b>0.560</b>	<b>0.590</b>		
	<b>Blue</b>	<b>B<sub>x</sub></b>		<b>0.120</b>	<b>0.150</b>	<b>0.180</b>		
		<b>B<sub>y</sub></b>		<b>0.100</b>	<b>0.130</b>	<b>0.160</b>		
	<b>White</b>	<b>W<sub>x</sub></b>		<b>0.283</b>	<b>0.313</b>	<b>0.343</b>		
		<b>W<sub>y</sub></b>		<b>0.299</b>	<b>0.329</b>	<b>0.359</b>		
<b>NTSC</b>	%			<b>45</b>				

**Note 1:** 5 points position (Ref: Active area)



**Note 2:** 13 points position (Ref: Active area)



**Note 3:** The luminance uniformity of 5 or 13 points is defined by dividing the maximum luminance values by the minimum test point luminance

$$\delta_{w5} = \frac{\text{Maximum Brightness of five points}}{\text{Minimum Brightness of five points}}$$

$$\delta_{w13} = \frac{\text{Maximum Brightness of thirteen points}}{\text{Minimum Brightness of thirteen points}}$$

**Note 4:** Measurement method

The LCD module should be stabilized at given temperature for 30 minutes to avoid abrupt temperature change during measuring. In order to stabilize the luminance, the measurement should be executed after lighting

Backlight for 30 minutes in a stable, windless and dark room, and it should be measured in the center of screen.

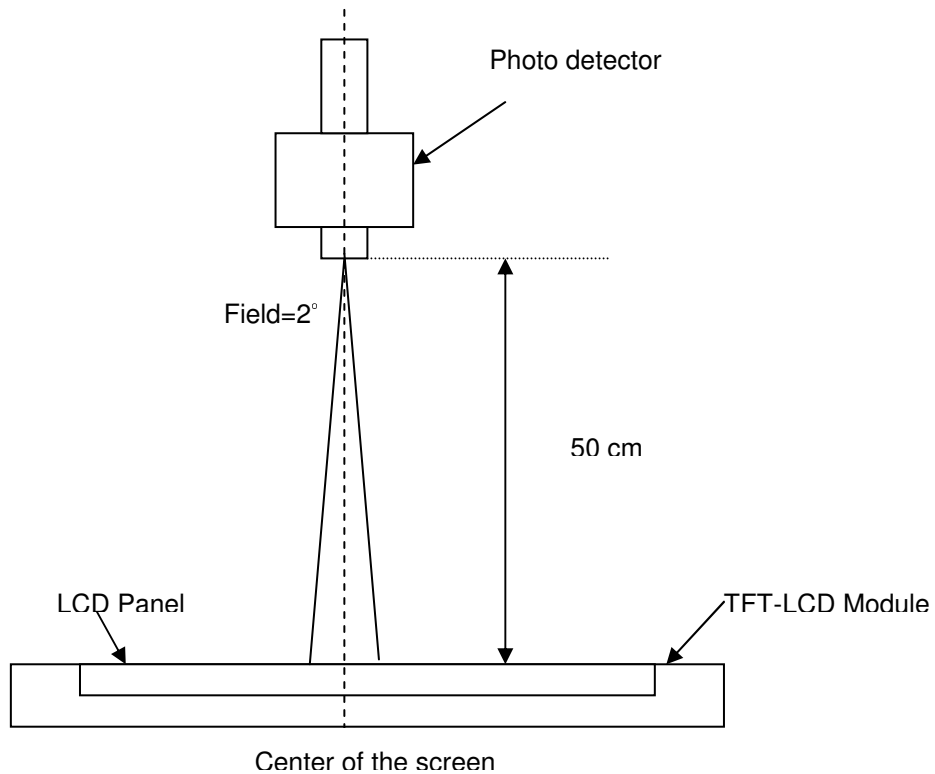

**Note 5 :** Definition of Average Luminance of White ( $Y_L$ ):

Measure the luminance of gray level 63 at 5 points ,  $Y_L = [L (1)+ L (2)+ L (3)+ L (4)+ L (5)] / 5$

$L (x)$  is corresponding to the luminance of the point X at Figure in Note (1).

**Note 6 :** Definition of contrast ratio:

Contrast ratio is calculated with the following formula.

$$\text{Contrast ratio (CR)} = \frac{\text{Brightness on the "White" state}}{\text{Brightness on the "Black" state}}$$

**Note 7 :** Definition of Cross Talk (CT)

$$CT = | Y_B - Y_A | / Y_A \times 100 (\%)$$

Where

$Y_A$  = Luminance of measured location without gray level 0 pattern (cd/m<sup>2</sup>)

$Y_B$  = Luminance of measured location with gray level 0 pattern (cd/m<sup>2</sup>)



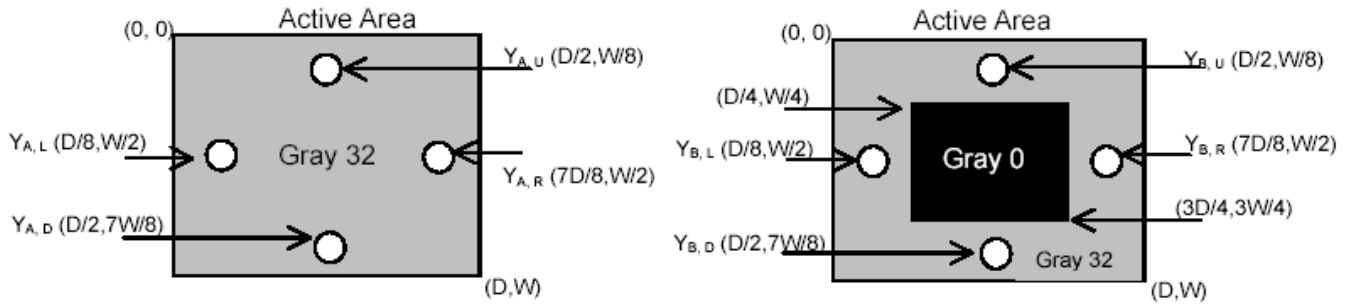

**Note 8:** Definition of response time:

The output signals of BM-7 or equivalent are measured when the input signals are changed from "Black" to "White" (falling time) and from "White" to "Black" (rising time), respectively. The response time interval between the 10% and 90% of amplitudes. Refer to figure as below.

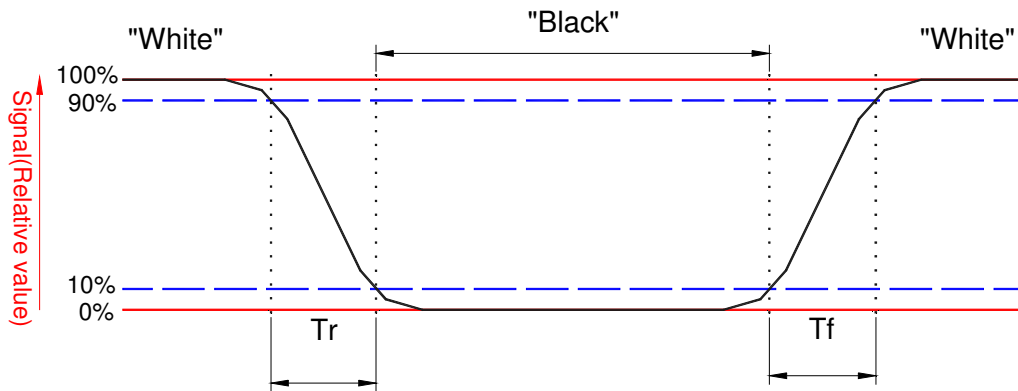

**Note 9.** Definition of viewing angle

Viewing angle is the measurement of contrast ratio  $\geq 10$ , at the screen center, over a  $180^\circ$  horizontal and  $180^\circ$  vertical range (off-normal viewing angles). The  $180^\circ$  viewing angle range is broken down as follows;  $90^\circ$  ( $\theta$ ) horizontal left and right and  $90^\circ$  ( $\phi$ ) vertical, high (up) and low (down). The measurement direction is typically perpendicular to the display surface with the screen rotated about its center to develop the desired measurement viewing angle.

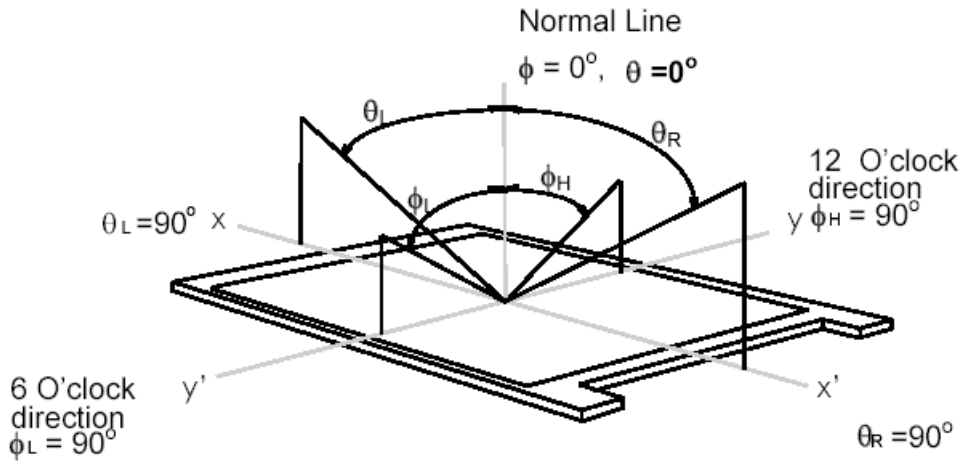

## 3. Functional Block Diagram

The following diagram shows the functional block of the 14.0 inches wide Color TFT/LCD 40 Pin one channel Module

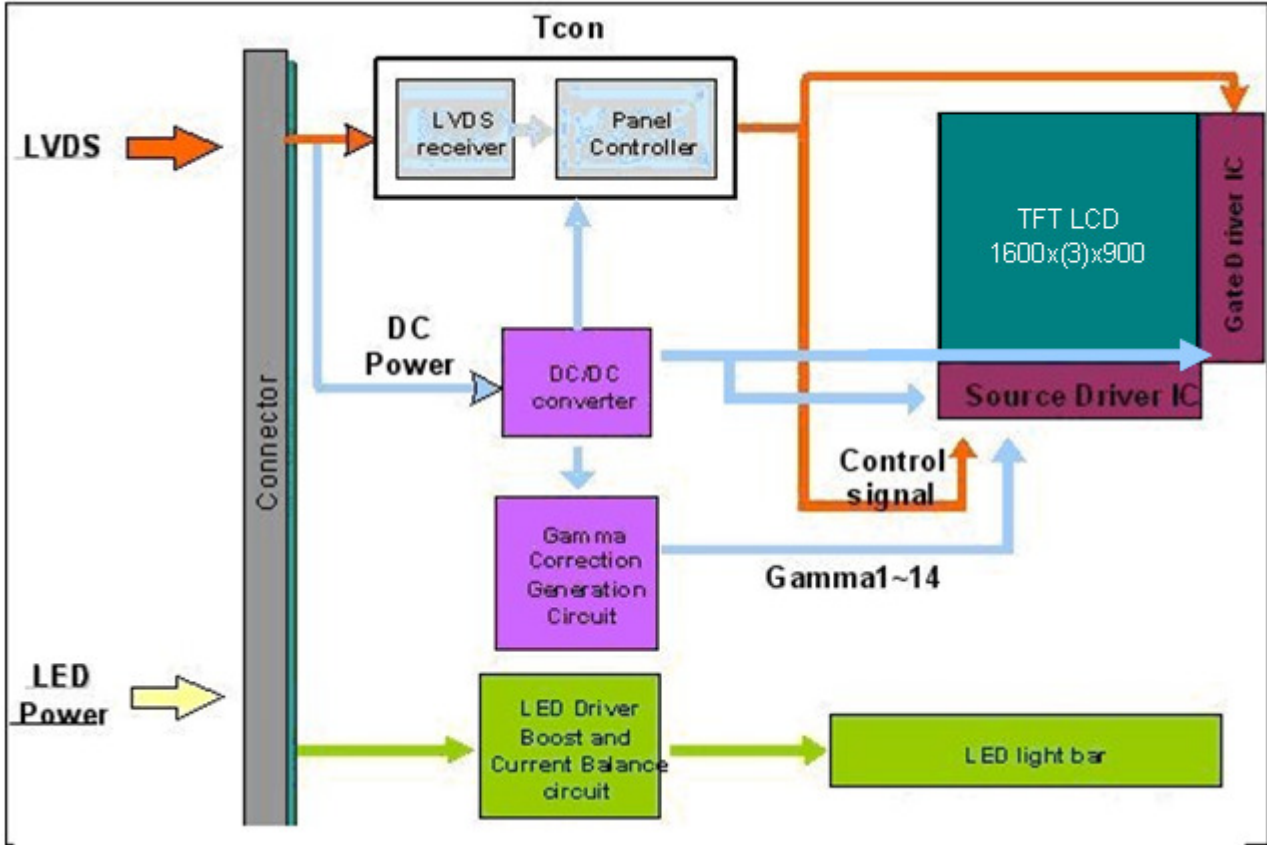

## 4. Absolute Maximum Ratings

An absolute maximum rating of the module is as following:

### 4.1 Absolute Ratings of TFT LCD Module

Item	Symbol	Min	Max	Unit	Conditions
Logic/LCD Drive Voltage	Vin	-0.3	+4.0	[Volt]	Note 1,2

### 4.2 Absolute Ratings of Environment

Item	Symbol	Min	Max	Unit	Conditions
Operating Temperature	TOP	0	+50	[°C]	Note 4
Operation Humidity	HOP	5	95	[%RH]	Note 4
Storage Temperature	TST	-20	+60	[°C]	Note 4
Storage Humidity	HST	5	95	[%RH]	Note 4

Note 1: At Ta (25°C)

Note 2: Permanent damage to the device may occur if exceed maximum values

Note 3: LED specification refer to section 5.2

Note 4: For quality performance, please refer to AUO IIS (Incoming Inspection Standard).

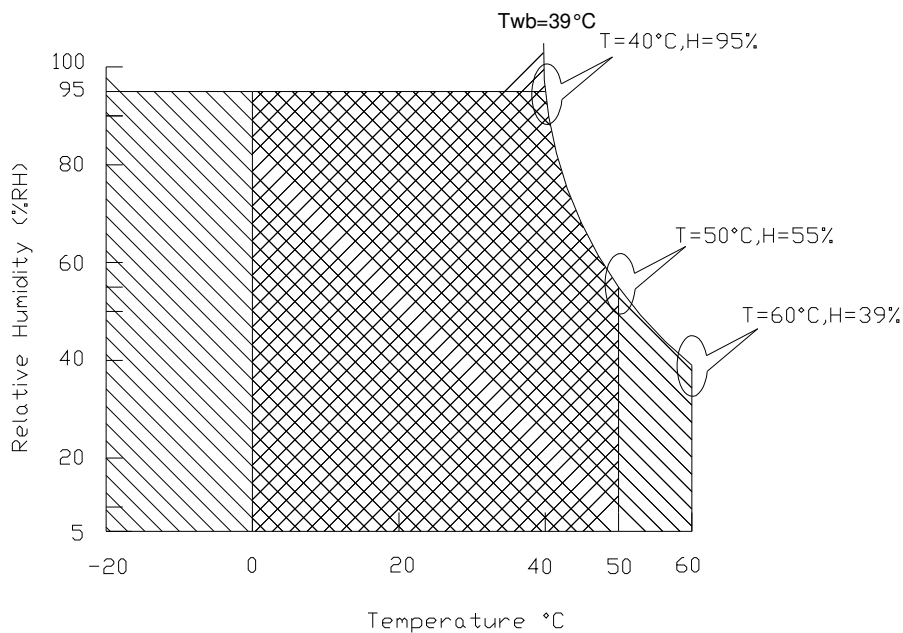

Operating Range 

Storage Range

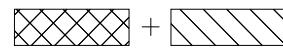

## 5. Electrical Characteristics

### 5.1 TFT LCD Module

#### 5.1.1 Power Specification

Input power specifications are as follows;

The power specification are measured under 25°C and frame frequency under 60Hz

Symbol	Parameter	Min	Typ	Max	Units	Note
VDD	Logic/LCD Drive Voltage	3.0	3.3	3.6	[Volt]	
PDD	VDD Power	-	-	1.5	[Watt]	Note 1
IDD	IDD Current	-	-	454	[mA]	Note 1
IRush	Inrush Current	-	-	2000	[mA]	Note 2
VDDrp	Allowable Logic/LCD Drive Ripple Voltage	-	-	100	[mV] p-p	

Note 1 : Maximum Measurement Condition : Black Pattern at 3.3V driving voltage. ( $P_{max} = V_{3.3} \times I_{black}$ )

Note 2 : Measure Condition

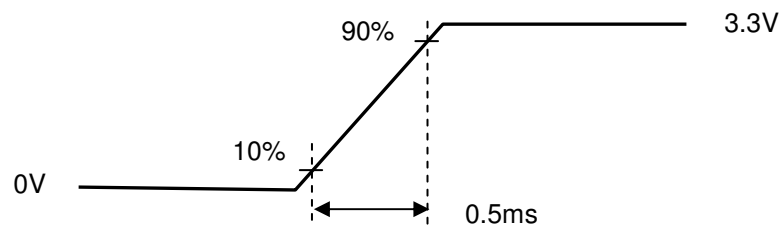
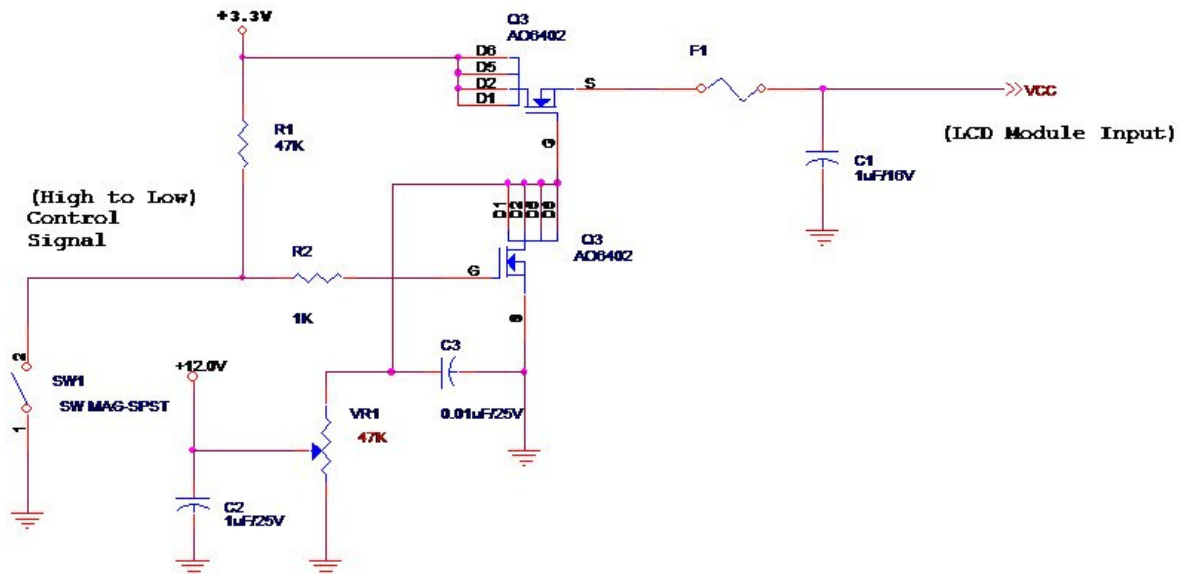

Vin rising time

## 5.1.2 Signal Electrical Characteristics

Signal electrical characteristics are as follows;

Parameter	Condition	Min	Max	Unit
$V_{TH}$	Differential Input High Threshold ( $V_{cm}=+1.2V$ )		100	[mV]
$V_{TL}$	Differential Input Low Threshold ( $V_{cm}=+1.2V$ )	-100	-	[mV]
$V_{CM}$	Differential Input Common Mode Voltage	1.125	1.375	[V]

Note: LVDS Signal Waveform

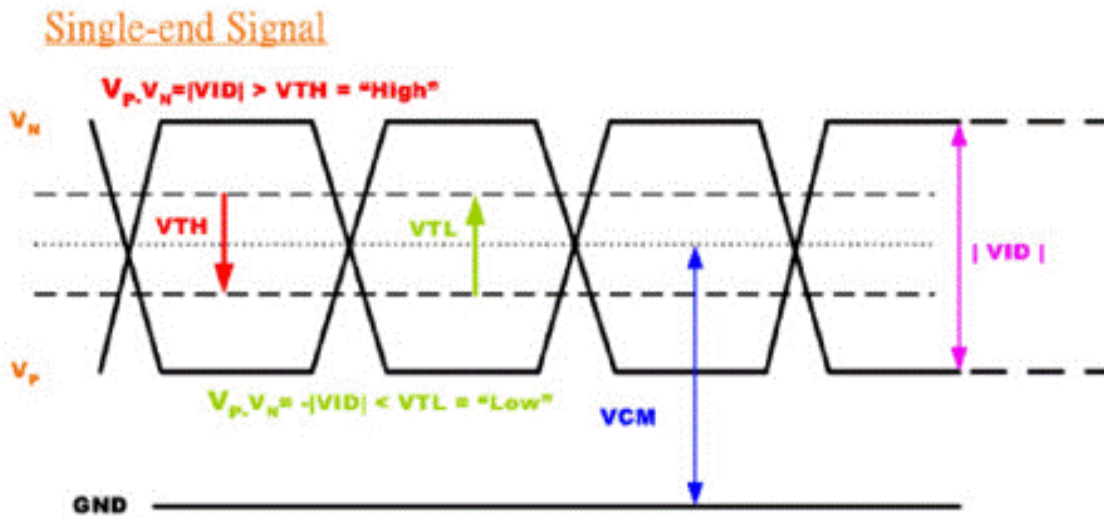

## 5.2 Backlight Unit

### 5.2.1 LED characteristics

Parameter	Symbol	Min	Typ	Max	Units	Condition
Backlight Power Consumption	PLED	-	-	2.5	[Watt]	(Ta=25°C), Note 1 Vin =12V
LED Life-Time	N/A	10000	-	-	Hour	(Ta=25°C), Note 2 If=20 mA

**Note 1:** Calculator value for reference  $P_{LED} = V_F$  (Normal Distribution) \*  $I_F$  (Normal Distribution) / Efficiency

**Note 2:** The LED life-time define as the estimated time to 50% degradation of initial luminous.

### 5.2.2 Backlight input signal characteristics

Parameter	Symbol	Min	Typ	Max	Units	Remark
LED Power Supply	VLED	6.0	12.0	21.0	[Volt]	Define as Connector Interface (Ta=25°C)
LED Enable Input High Level	VLED_EN	2.5	-	5.5	[Volt]	
LED Enable Input Low Level		-	-	0.8	[Volt]	
PWM Logic Input High Level	VPWM_EN	2.5	-	5.5	[Volt]	
PWM Logic Input Low Level		-	-	0.8	[Volt]	
PWM Input Frequency	FPWM	200	-	20K	Hz	
PWM Duty Ratio	Duty	5	--	100	%	

## 6. Signal Interface Characteristic

### 6.1 Pixel Format Image

Following figure shows the relationship of the input signals and LCD pixel format.

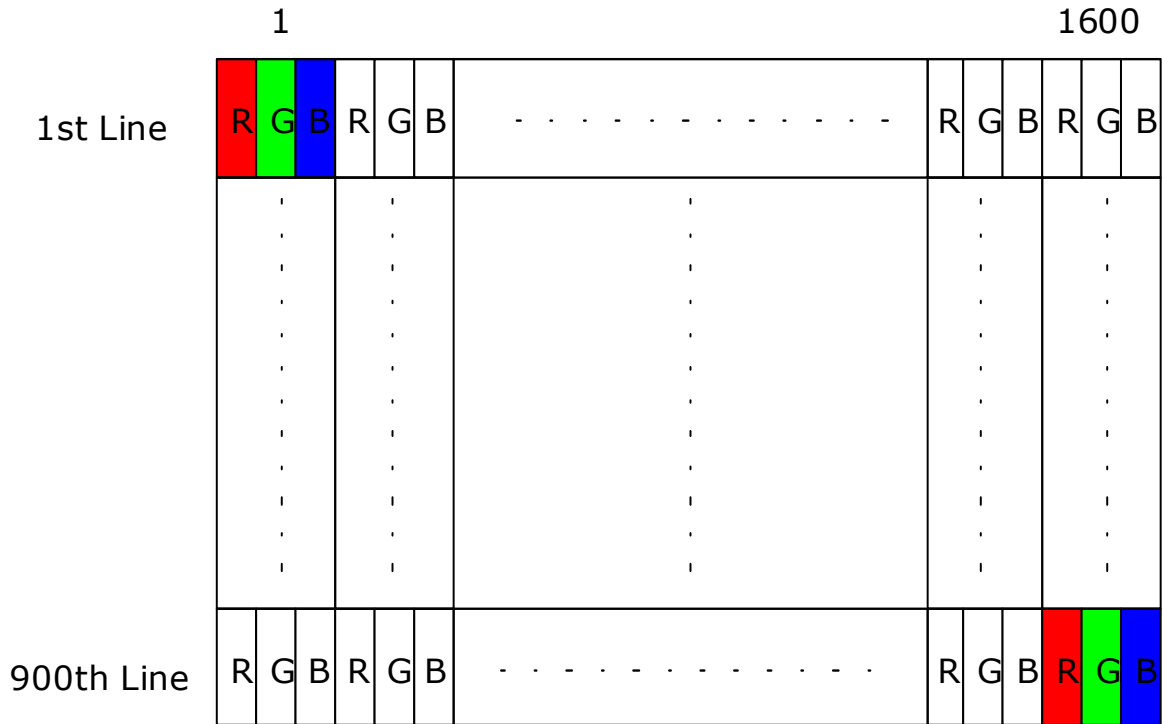



## 6.2 The Input Data Format





# Product Specification

AU OPTRONICS CORPORATION

Signal Name	Description	
R5 R4 R3 R2 R1 R0	Red Data 5 (MSB) Red Data 4 Red Data 3 Red Data 2 Red Data 1 Red Data 0 (LSB)  Red-pixel Data	Red-pixel Data Each red pixel's brightness data consists of these 6 bits pixel data.
G5 G4 G3 G2 G1 G0	Green Data 5 (MSB) Green Data 4 Green Data 3 Green Data 2 Green Data 1 Green Data 0 (LSB)  Green-pixel Data	Green-pixel Data Each green pixel's brightness data consists of these 6 bits pixel data.
B5 B4 B3 B2 B1 B0	Blue Data 5 (MSB) Blue Data 4 Blue Data 3 Blue Data 2 Blue Data 1 Blue Data 0 (LSB)  Blue-pixel Data	Blue-pixel Data Each blue pixel's brightness data consists of these 6 bits pixel data.
RxCLKIN	Data Clock	The signal is used to strobe the pixel data and DE signals. All pixel data shall be valid at the falling edge when the DE signal is high.
DE	Display Timing	This signal is strobed at the falling edge of RxCLKIN. When the signal is high, the pixel data shall be valid to be displayed.
VS	Vertical Sync	The signal is synchronized to RxCLKIN .
HS	Horizontal Sync	The signal is synchronized to RxCLKIN .

Note: Output signals from any system shall be low or High-impedance state when VDD is off.

## 6.3 Integration Interface Requirement

### 6.3.1 Connector Description

Physical interface is described as for the connector on module.

These connectors are capable of accommodating the following signals and will be following components.

<b>Connector Name / Designation</b>	<b>For Signal Connector</b>
Manufacturer	<b>IPEX or Compatible</b>
Type / Part Number	<b>IPEX 20455-040E-12R or Compatible</b>
Mating Housing/Part Number	<b>IPEX 20453-040T-11 or Compatible</b>

### 6.3.2 Pin Assignment

LVDS is a differential signal technology for LCD interface and high speed data transfer device.

PIN #	SIGNAL NAME	DESCRIPTION
1	NC	NC
2	VDD	+ 3.3V Power Supply
3	VDD	+ 3.3V Power Supply
4	VEDID	+ 3.3V EDID Power
5	N.C	No Connect.
6	CLKEDID	EDID Clock Input
7	DATAEDID	EDID Data Input
8	Odd_Rin0-	-LVDS Differential Data Input
9	Odd_Rin0+	+LVDS Differential Data Input
10	VSS	Power Ground
11	Odd_Rin1-	-LVDS Differential Data Input
12	Odd_Rin1+	+LVDS Differential Data Input
13	VSS	Power Ground
14	Odd_Rin2-	-LVDS Differential Data Input
15	Odd_Rin2+	+LVDS Differential Data Input
16	VSS	Power Ground
17	Odd_ClkIN-	-LVDS Differential Clock Input
18	Odd_ClkIN+	+LVDS Differential Clock Input
19	VSS	Ground
20	Even_Rin0-	-LVDS Differential Data Input
21	Even_Rin0+	+LVDS Differential Data Input



# Product Specification

AU OPTRONICS CORPORATION

22	VSS	Power Ground
23	Even_Rin1-	-LVDS Differential Data Input
24	Even_Rin1+	+LVDS Differential Data Input
25	VSS	Power Ground
26	Even_Rin2-	-LVDS Differential Data Input
27	Even_Rin2+	+LVDS Differential Data Input
28	VSS	Power Ground
29	Even_ClkIN-	-LVDS Differential Clock Input
30	Even_ClkIN+	+LVDS Differential Clock Input
31	VLED_GND	LED_GND
32	VLED_GND	LED_GND
33	VLED_GND	LED_GND
34	NC	NC
35	S-PWM	
36	LED_EN	
37	NC	NC
38	VLED	LED_Positive (6~21)
39	VLED	LED_Positive(6~21)
40	VLED	LED_Positive(6~21)

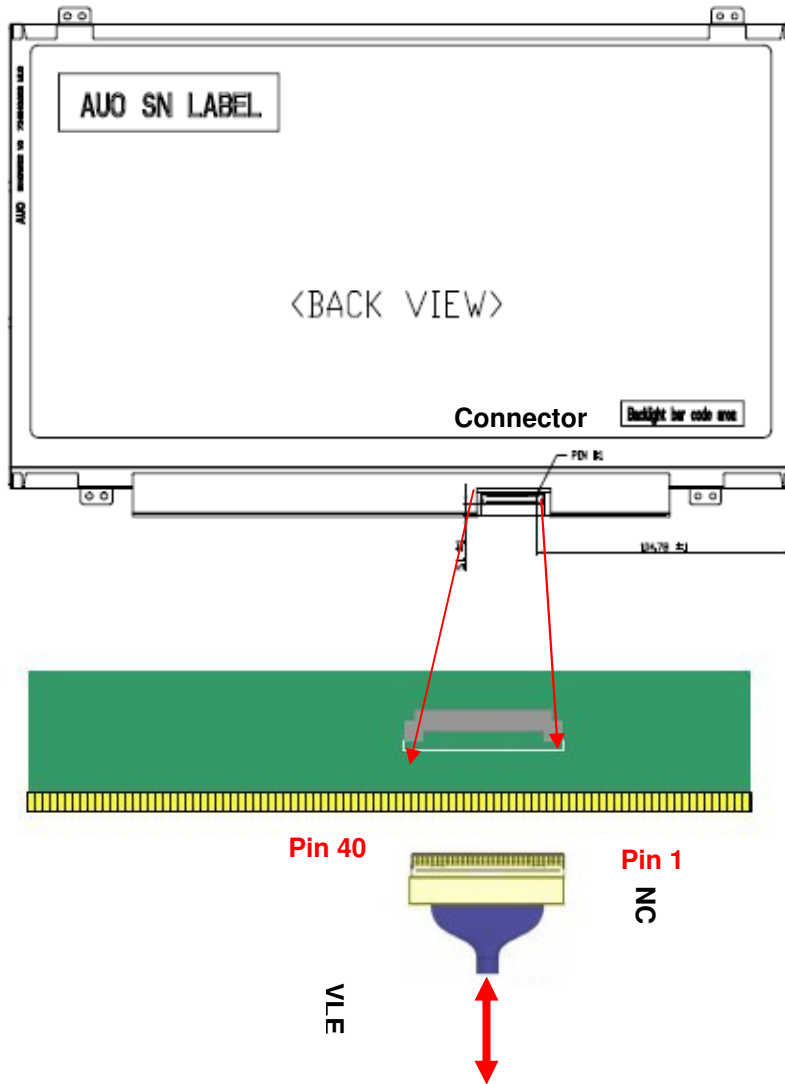

Note1: Input signals shall be low or High-impedance state when VDD is off.

## 6.4 Interface Timing

### 6.4.1 Timing Characteristics

Basically, interface timings should match the 1600x900 /60Hz manufacturing guide line timing.

Parameter	Symbol	Min.	Typ.	Max.	Unit	
Frame Rate	-	50	60	-	Hz	
Clock frequency	$1/T_{\text{Clock}}$		53.9		MHz	
Vertical Section	Period	$T_V$	908	912	2047	$T_{\text{Line}}$
	Active	$T_{VD}$	900			
	Blanking	$T_{VB}$	8	12	-	
Horizontal Section	Period	$T_H$	840	1006	2047	$T_{\text{Clock}}$
	Active	$T_{HD}$	800			
	Blanking	$T_{HB}$	40	206		

Note : DE mode only

## 6.4.2 Timing diagram

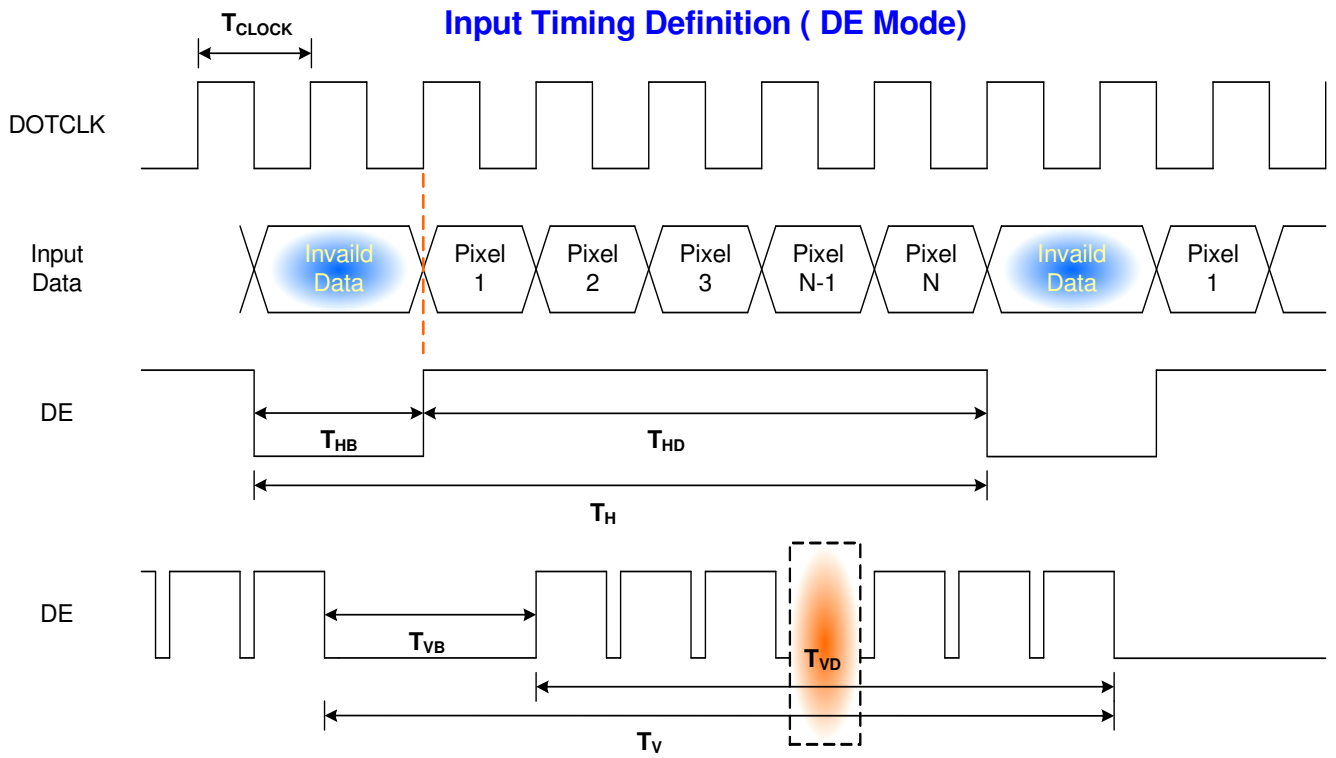

## 6.5 Power ON/OFF Sequence

VDD power on/off sequence is as follows. Interface signals are also shown in the chart. Signals from any system shall be Hi-Z state or low level when VDD is off

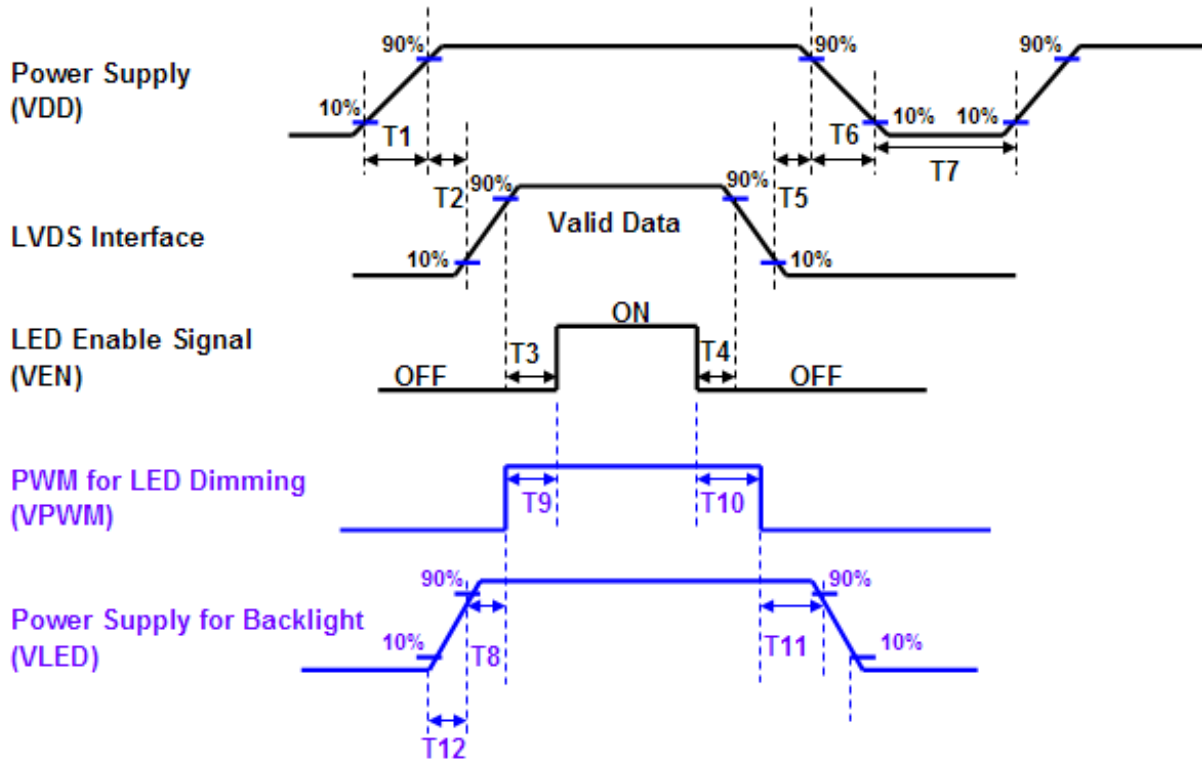

Power Sequence Timing			
Parameter	Value		Units
	Min.	Max.	
T1	0.5	10	ms
T2	0	50	
T3	250	-	
T4	200	-	
T5	0	50	
T6	0	10	
T7	500	-	
T8	10	-	
T9	10	180	
T10	10	180	
T11	10	-	
T12	0.5	10	

## 7. Panel Reliability Test

### 7.1 Vibration Test

**Test Spec:**

- Test method: Non-Operation
- Acceleration: 1.5 G
- Frequency: 10 - 500Hz Random
- Sweep: 30 Minutes each Axis (X, Y, Z)

### 7.2 Shock Test

**Test Spec:**

- Test method: Non-Operation
- Acceleration: 220 G , Half sine wave
- Active time: 2 ms
- Pulse: X,Y,Z .one time for each side

### 7.3 Reliability Test

Items	Required Condition	Note
Temperature Humidity Bias	Ta= 40°C, 90%RH, 300h	
High Temperature Operation	Ta= 50°C, Dry, 300h	
Low Temperature Operation	Ta= 0°C, 300h	
High Temperature Storage	Ta= 60°C, 35%RH, 300h	
Low Temperature Storage	Ta= -20°C, 50%RH, 250h	
Thermal Shock Test	Ta=-20°Cto 60°C, Duration at 30 min, 100 cycles	
ESD	Contact : ±8 KV Air : ±15 KV	Note 1

**Note1:** According to EN 61000-4-2 , ESD class B: Some performance degradation allowed. No data lost  
 . Self-recoverable. No hardware failures.

**Remark:** MTBF (Excluding the LED): 30,000 hours with a confidence level 90%



## 8. Mechanical Characteristics

### 8.1 LCM Outline Dimension

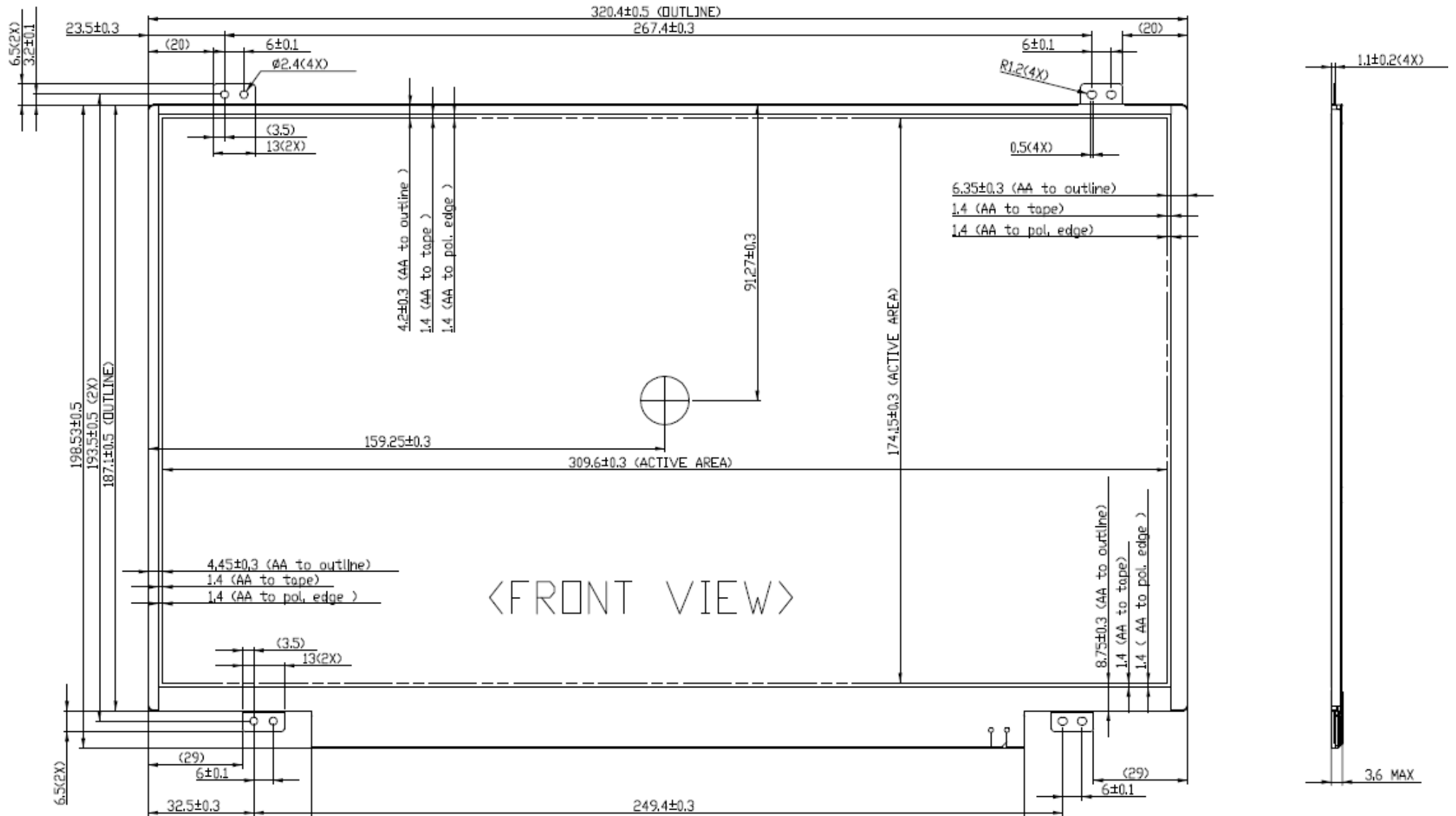

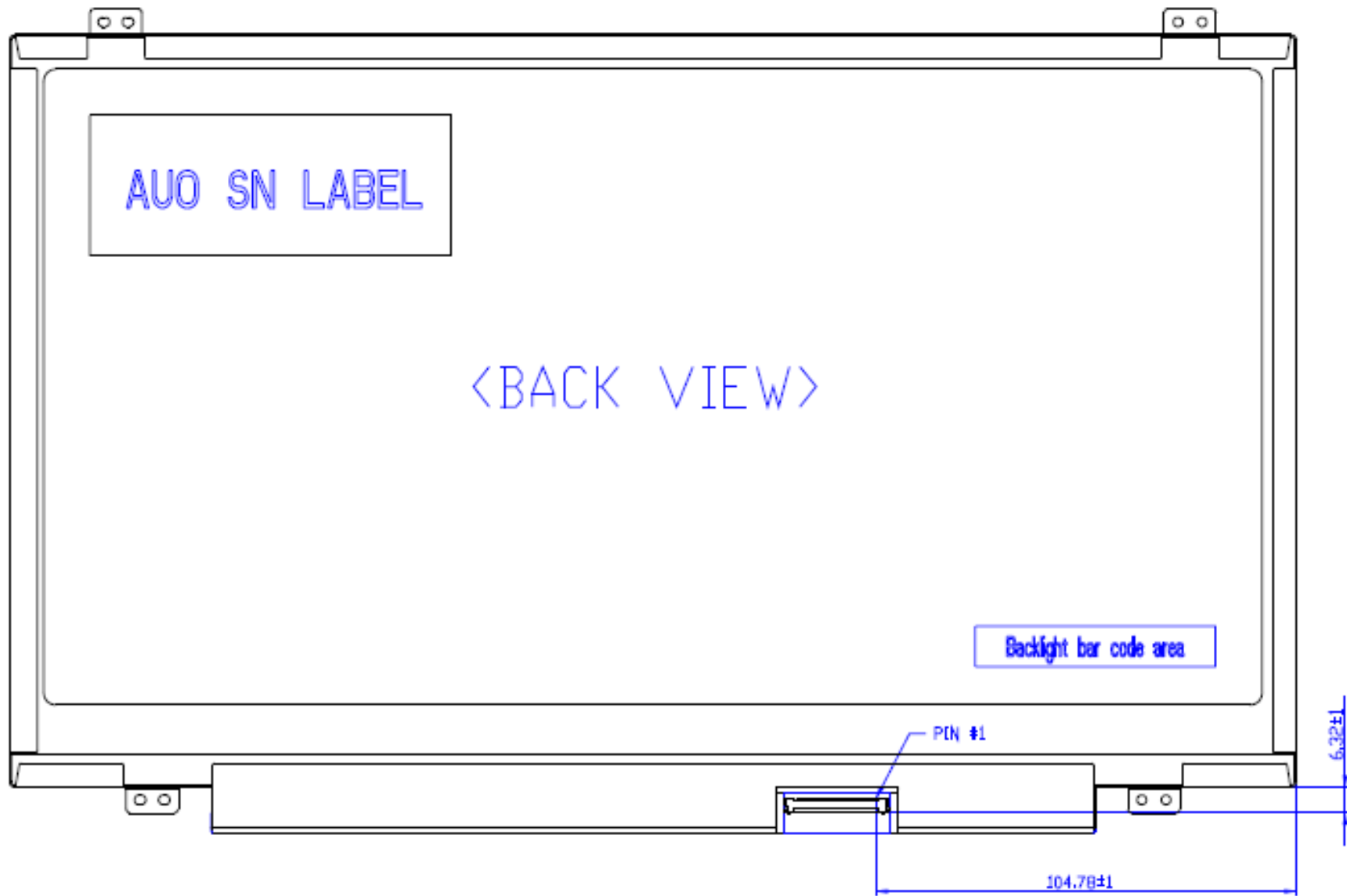

Note: Prevention IC damage, IC positions not allowed any overlap over these areas.

## 9. Shipping and Package

### 9.1 Shipping /Carton Label Format

 *XXXXXXXXXXXX-XXXXXX	Manufactured XX/XX Model No: <b>B140RW02 V2</b> AU Optronics Made in China (S01)	   
 CT: <b>CBRRF016RXXXXX</b>	H/W: <b>0A</b> F/W:1	

AU Optronics	QTY : 25		
MODEL NO : <b>B140RW02V2</b>			
PART NO : <b>97.14B42.200</b>			
CUSTOMER NO : <b>629800-392</b>			
CARTON NO :			
Made in China	*ZM100-0652300205*		

## 9.2 Carton Package

The outside dimension of carton is 455 (L)mm x 380 (W)mm x 355 (H)mm

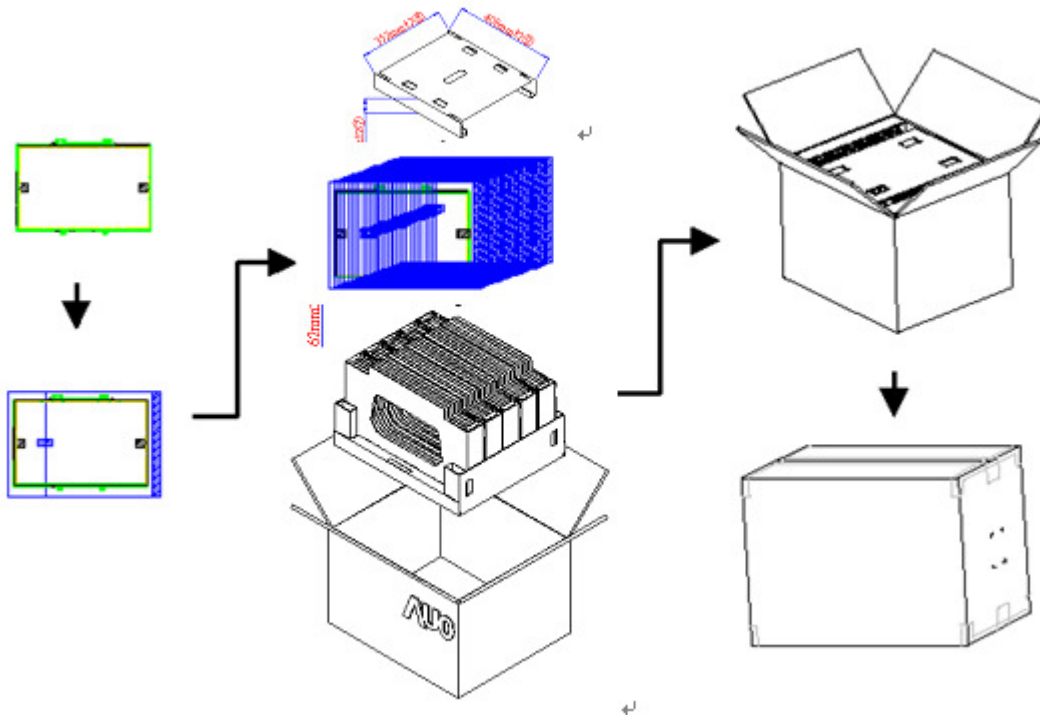

## 9.3 Shipping Package of Palletizing Sequence

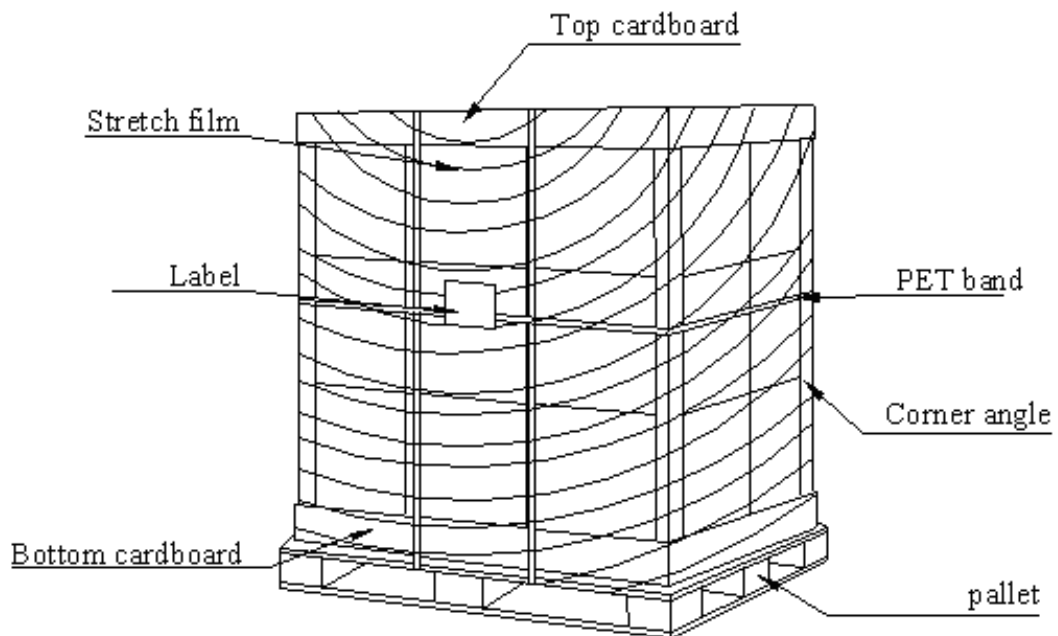

## 10. Appendix: EDID Description

Address	FUNCTION	Value	Value	Value	Note
HEX		HEX	BIN	DEC	
00	Header	00	00000000	0	
01		FF	11111111	255	
02		FF	11111111	255	
03		FF	11111111	255	
04		FF	11111111	255	
05		FF	11111111	255	
06		FF	11111111	255	
07		00	00000000	0	
08	EISA Manuf. Code LSB	06	00000110	6	
09	Compressed ASCII	AF	10101111	175	
0A	Product Code	3E	00111110	62	
0B	hex, LSB first	22	00100010	34	
0C	32-bit ser #	00	00000000	0	
0D		00	00000000	0	
0E		00	00000000	0	
0F		00	00000000	0	
10	Week of manufacture	22	00100010	34	
11	Year of manufacture	14	00010100	20	
12	EDID Structure Ver.	01	00000001	1	
13	EDID revision #	03	00000011	3	
14	<b>Video input def. (digital I/P, non-TMDS, CRGB)</b>	80	10000000	128	
15	<b>Max H image size (rounded to cm)</b>	1F	00011111	31	
16	<b>Max V image size (rounded to cm)</b>	11	00010001	17	
17	<b>Display Gamma (=gamma*100)-100</b>	78	01111000	120	
18	<b>Feature support (no DPMS, Active OFF, RGB, tmg Blk#1)</b>	0A	00001010	10	
19	Red/green low bits (Lower 2:2:2:2 bits)	61	01100001	97	
1A	Blue/white low bits (Lower 2:2:2:2 bits)	95	10010101	149	
1B	Red x (Upper 8 bits)	9C	10011100	156	
1C	Red y/ highER 8 bits	59	01011001	89	
1D	Green x	52	01010010	82	
1E	Green y	8F	10001111	143	
1F	Blue x	26	00100110	38	
20	Blue y	21	00100001	33	
21	White x	50	01010000	80	
22	White y	54	01010100	84	
23	Established timing 1	00	00000000	0	
24	Established timing 2	00	00000000	0	
25	Established timing 3	00	00000000	0	
26	Standard timing #1	01	00000001	1	
27		01	00000001	1	
28	Standard timing #2	01	00000001	1	
29		01	00000001	1	
2A	Standard timing #3	01	00000001	1	
2B		01	00000001	1	
2C	Standard timing #4	01	00000001	1	

2D		01	00000001	1	
2E	Standard timing #5	01	00000001	1	
2F		01	00000001	1	
30	Standard timing #6	01	00000001	1	
31		01	00000001	1	
32	Standard timing #7	01	00000001	1	
33		01	00000001	1	
34	Standard timing #8	01	00000001	1	
35		01	00000001	1	
36	Pixel Clock/10000 LSB	1C	00011100	28	
37	Pixel Clock/10000 USB	2A	00101010	42	
38	Horz active Lower 8bits	40	01000000	64	
39	Horz blanking Lower 8bits	72	01110010	114	
3A	HorzAct:HorzBlnk Upper 4:4 bits	61	01100001	97	
3B	Vertical Active Lower 8bits	84	10000100	132	
3C	Vertical Blanking Lower 8bits	0C	00001100	12	
3D	Vert Act : Vertical Blanking (upper 4:4 bit)	30	00110000	48	
3E	HorzSync. Offset	40	01000000	64	
3F	HorzSync.Width	2A	00101010	42	
40	VertSync.Offset : VertSync.Width	33	00110011	51	
41	Horz&Vert Sync Offset/Width Upper 2bits	00	00000000	0	
42	Horizontal Image Size Lower 8bits	35	00110101	53	
43	Vertical Image Size Lower 8bits	AE	10101110	174	
44	Horizontal & Vertical Image Size (upper 4:4 bits)	10	00010000	16	
45	Horizontal Border (zero for internal LCD)	00	00000000	0	
46	Vertical Border (zero for internal LCD)	00	00000000	0	
47	Signal (non-intr, norm, no stereo, sep sync, neg pol)	18	00011000	24	
48	Pixel Clock/10,000 (LSB)	13	00010011	19	
49	Pixel Clock/10,000 (MSB)	1C	00011100	28	40Hz frame rate
4A	Horizontal Addressable Pixels, lower 8 bits	40	01000000	64	
4B	Horizontal Blanking Pixels, lower 8 bits	72	01110010	114	
4C	H Pixels, upper nibble : H Blanking, upper nibble	61	01100001	97	
4D	Vertical Addressable Lines, lower 8 bits	84	10000100	132	
4E	Vertical Blanking Lines, lower 8 bits	0C	00001100	12	
4F	V lines, upper nibble : V blanking, upper nibble	30	00110000	48	
50	Horizontal Front Porch, lower 8 bits	40	01000000	64	
51	Horizontal Sync Pulse, lower 8 bits	2A	00101010	42	
52	V Front Porch, lower nibble : V Sync Pulse, lower nibble	33	00110011	51	
53	VFP, 2 bits: VSP 2 bits: HFP 2 bits: HFP 2 bits	00	00000000	0	
54	Horizontal Image Size in mm, lower 8 bits	35	00110101	53	
55	Vertical Image Size in mm, lower 8 bits	AE	10101110	174	
56	H Image Size, upper nibble : V Image Size, upper nibble	10	00010000	16	
57	Horizontal Border	00	00000000	0	
58	Vertical Border	00	00000000	0	
59	Bit Encode Sync Information	18	00011000	24	
5A	DC	00	00000000	0	nVDPS Reserved 00
5B	HTOTAL	00	00000000	0	
5C	HA	00	00000000	0	
5D	HBL	00	00000000	0	

5E	HFP	00	00000000	0	
5F	HFPe	00	00000000	0	
60	HBP	00	00000000	0	
61	HB	00	00000000	0	
62	HSO	00	00000000	0	
63	HS	00	00000000	0	
64	VTOTAL	00	00000000	0	
65	VA	00	00000000	0	
66	VBL	00	00000000	0	
67	VFP	00	00000000	0	
68	VBP	00	00000000	0	
69	VB	00	00000000	0	
6A	VSO	00	00000000	0	
6B	VS	00	00000000	0	
6C	Detail Timing Description #4	00	00000000	0	
6D	Flag	00	00000000	0	
6E	Reserved	00	00000000	0	
6F	For Brightness Table and Power Consumption	02	00000010	2	
70	Flag	00	00000000	0	Header
71	PWM % [7:0] @ Step 0	0B	00001011	11	
72	PWM % [7:0] @ Step 5	48	01001000	72	
73	PWM % [7:0] @ Step 10	F5	11110101	245	
74	Nits [7:0] @ Step 0	0A	00001010	10	
75	Nits [7:0] @ Step 5	3C	00111100	60	Brightness Table
76	Nits [7:0] @ Step 10	64	01100100	100	
77	Panel Electronics Power @ 32x32 Chess Pattern =	14	00010100	20	
78	Backlight Power @ 60 nits =	0E	00001110	14	
79	Backlight Power @ Step 10 =	1A	00011010	26	
7A	Nits @ 100% PWM Duty =	68	01101000	104	Power Consumption
7B	Flag	20	00100000	32	
7C	Flag	20	00100000	32	
7D	Flag	20	00100000	32	
7E	Extension Flag	00	00000000	0	
7F	Checksum	5B	01011011	91	