



Product Specification

AU OPTRONICS CORPORATION

() Preliminary Specifications

(V) Final Specifications

Module	14.0" (13.98") HD+ 16:9 Color TFT-LCD with LED Backlight design
Model Name	B140RW03 V1 (H/W:0A)
Note ()	<i>LED Backlight with driving circuit design</i>

Customer	Date
Checked & Approved by	Date
Note: This Specification is subject to change without notice.	

Approved by	Date
<u>Bonnie Chen</u>	<u>01/10/2011</u>
Prepared by	Date
<u>HsinYin Yu</u>	<u>01/10/2011</u>
NBBU Marketing Division AU Optronics corporation	



Contents

1. Handling Precautions	4
2. General Description	5
2.1 General Specification	5
2.2 Optical Characteristics	6
3. Functional Block Diagram	11
4. Absolute Maximum Ratings	12
4.1 Absolute Ratings of TFT LCD Module	12
4.2 Absolute Ratings of Environment	12
5. Electrical Characteristics	13
5.1 TFT LCD Module	13
5.2 Backlight Unit	15
6. Signal Interface Characteristic	16
6.1 Pixel Format Image	16
6.2 The Input Data Format	17
6.3 Integration Interface Requirement	19
6.4 Interface Timing	21
7. Panel Reliability Test	24
7.1 Vibration Test	24
7.2 Shock Test	24
7.3 Reliability Test	24
8. Mechanical Characteristics	25
8.1 LCM Outline Dimension	25
9. Shipping and Package	27
9.1 Shipping /Carton Label Format	27
9.2 Carton Package	28
9.3 Shipping Package of Palletizing Sequence	28
10. Appendix: EDID Description	29



Product Specification

AU OPTRONICS CORPORATION

Record of Revision

Version and Date	Page	Old description	New Description	Remark
0.1 2010/10/05	All	First Edition for Customer		
0.2 2010/10/26	5	Wrong model name	Update correct model name	
	27	Old label information	Update label information	
	29	EDID TBD	New EDID information	
0.3 2010/12/03	5-6	General Specification TBD	Update Specification	
	13	Power Specification TBD	Update Power Specification	
	15	BLU power TBD	Update BLU power	
	19	Mating Housing TBD	Update Mating Housing	
1.0 2011/01/10	25-26	Old outline dimension	Update outline dimension	
	27	Old label information	Update label information	
	29-31	Old EDID information	Update EDID information	

1. Handling Precautions

- 1) Since front polarizer is easily damaged, pay attention not to scratch it.
- 2) Be sure to turn off power supply when inserting or disconnecting from input connector.
- 3) Wipe off water drop immediately. Long contact with water may cause discoloration or spots.
- 4) When the panel surface is soiled, wipe it with absorbent cotton or other soft cloth.
- 5) Since the panel is made of glass, it may break or crack if dropped or bumped on hard surface.
- 6) Since CMOS LSI is used in this module, take care of static electricity and insure human earth when handling.
- 7) Do not open nor modify the Module Assembly.
- 8) Do not press the reflector sheet at the back of the module to any directions.
- 9) At the insertion or removal of the Signal Interface Connector, be sure not to rotate nor tilt the Interface Connector of the TFT Module.
- 11) After installation of the TFT Module into an enclosure (Notebook PC Bezel, for example), do not twist nor bend the TFT Module even momentary. At designing the enclosure, it should be taken into consideration that no bending/twisting forces are applied to the TFT Module from outside. Otherwise the TFT Module may be damaged.
- 12) Small amount of materials having no flammability grade is used in the LCD module. The LCD module should be supplied by power complied with requirements of Limited Power Source (IEC60950 or UL1950), or be applied exemption.
- 13) Disconnecting power supply before handling LCD modules, it can prevent electric shock, DO NOT TOUCH the electrode parts, cables, connectors and LED circuit part of TFT module that a LED light bar build in as a light source of back light unit. It can prevent electrostatic breakdown.

2. General Description

B140RW03 V1 is a Color Active Matrix Liquid Crystal Display composed of a TFT LCD panel, a driver circuit, and LED backlight system. The screen format is intended to support the 16:9 HD, 1600(H) x900(V) screen and 262k colors (RGB 6-bits data driver) with LED backlight driving circuit. All input signals are LVDS interface compatible.

B140RW03 V1 is designed for a display unit of notebook style personal computer and industrial machine.

2.1 General Specification

The following items are characteristics summary on the table at 25 °C condition:

Items	Unit	Specifications			
Screen Diagonal	[mm]	354.95			
Active Area	[mm]	309.60 X 174.15			
Pixels H x V		1600x3(RGB) x 900			
Pixel Pitch	[mm]	0.1935X0.1935			
Pixel Format		R.G.B. Vertical Stripe			
Display Mode		Normally White			
White Luminance (I _{LED} =20mA) (Note: I _{LED} is LED current)	[cd/m ²]	300 typ. (5 points average)			
Luminance Uniformity		1.25 max. (5 points)			
Contrast Ratio		400 typ.			
Response Time	[ms]	8 typ / 16 Max			
Nominal Input Voltage VDD	[Volt]	+3.3 typ.			
Power Consumption	[Watt]	5.8 W (Include Logic and Blu power)			
Weight	[Grams]	350 max.			
Physical Size Include bracket	[mm]		Min.	Typ.	Max.
		Length			324
		Width			193
		Thickness			5.2
Electrical Interface		2 channel LVDS			
Glass Thickness	[mm]	0.5			
Surface Treatment		Anti-Glare, Hardness 3H,			
Support Color		262K colors (RGB 6-bit)			



Product Specification

AU OPTRONICS CORPORATION

Temperature Range Operating Storage (Non-Operating)	[°C] [°C]	0 to +50 -20 to +60
RoHS Compliance		RoHS Compliance

2.2 Optical Characteristics

The optical characteristics are measured under stable conditions at 25°C (Room Temperature) :

Item	Symbol	Conditions	Min.	Typ.	Max.	Unit	Note	
White Luminance $I_{LED=20mA}$		5 points average	250	300	-	cd/m ²	1, 4, 5.	
Viewing Angle	θ_R θ_L	Horizontal (Right) CR = 10 (Left)	40 40	45 45	- -	degree	4, 9	
	ψ_H ψ_L	Vertical (Upper) CR = 10 (Lower)	10 30	15 35	- -			
Luminance Uniformity	δ_{5P}	5 Points	-	-	1.25		1, 3, 4	
Luminance Uniformity	δ_{13P}	13 Points	-	-	1.50		2, 3, 4	
Contrast Ratio	CR		300	400	-		4, 6	
Cross talk	%				4		4, 7	
Response Time	T_r	Rising	-			msec	4, 8	
	T_f	Falling	-					
	T_{RT}	Rising + Falling	-	8	16			
Color / Chromaticity Coordinates	Red	Rx	CIE 1931	0.580	0.610	0.640	-	4
		Ry		0.320	0.350	0.380		
	Green	Gx		0.290	0.320	0.350		
		Gy		0.530	0.560	0.590		
	Blue	Bx		0.120	0.150	0.180		
		By		0.100	0.130	0.160		
	White	Wx		0.283	0.313	0.343		
		Wy		0.299	0.329	0.359		
NTSC	%			45				

Note 1: 5 points position (Ref: Active area)



Note 2: 13 points position (Ref: Active area)

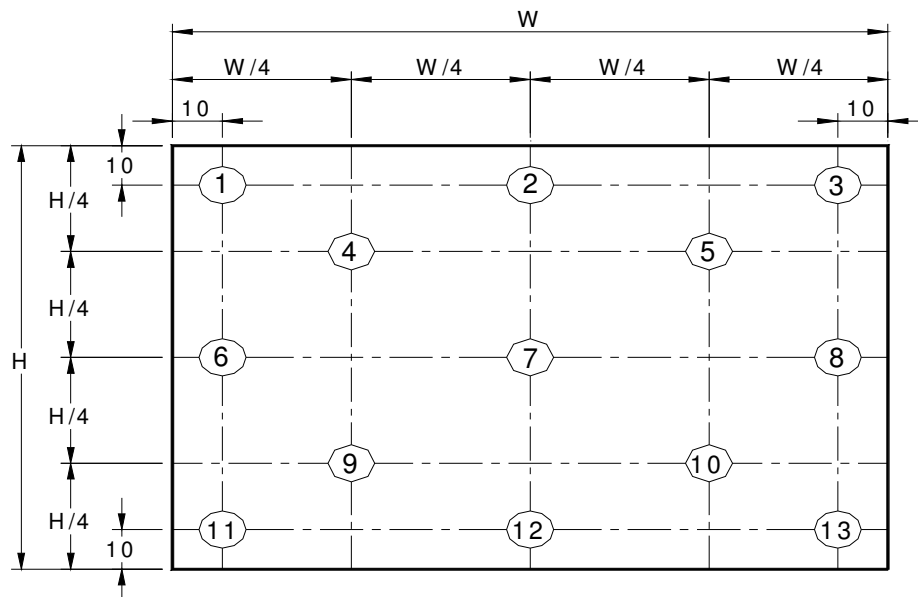

Note 3: The luminance uniformity of 5 or 13 points is defined by dividing the maximum luminance values by the minimum test point luminance

$$\delta_{W5} = \frac{\text{Maximum Brightness of five points}}{\text{Minimum Brightness of five points}}$$

$$\delta_{W13} = \frac{\text{Maximum Brightness of thirteen points}}{\text{Minimum Brightness of thirteen points}}$$

Note 4: Measurement method

The LCD module should be stabilized at given temperature for 30 minutes to avoid abrupt temperature change during measuring. In order to stabilize the luminance, the measurement should be executed after lighting

Backlight for 30 minutes in a stable, windless and dark room, and it should be measured in the center of screen.

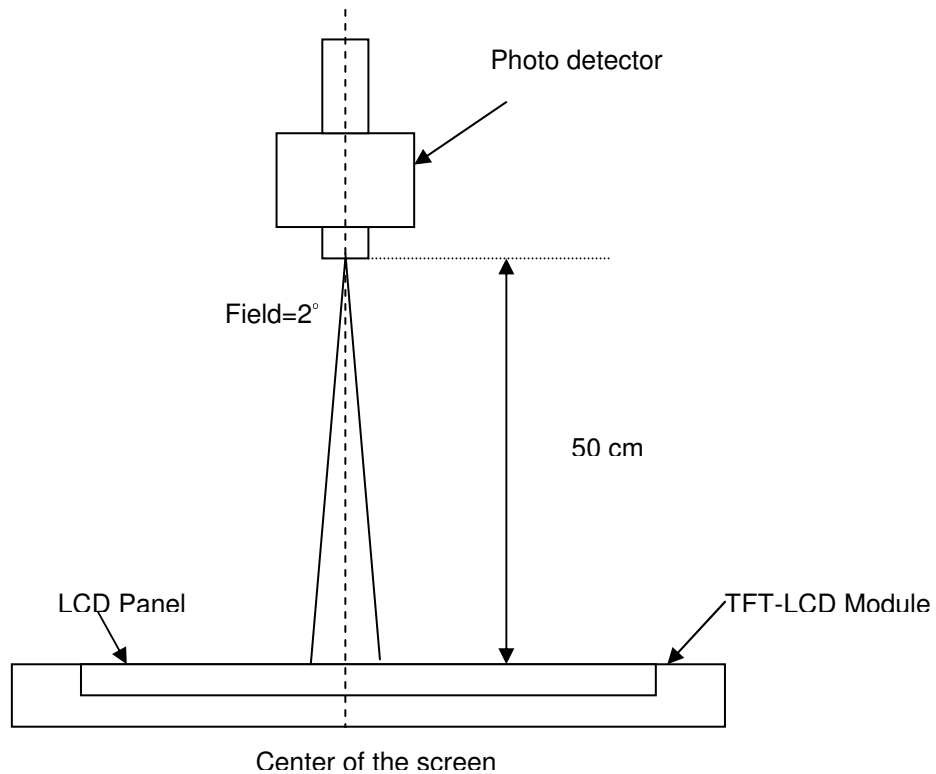

Note 5 : Definition of Average Luminance of White (Y_L):

Measure the luminance of gray level 63 at 5 points , $Y_L = [L (1)+ L (2)+ L (3)+ L (4)+ L (5)] / 5$

$L (x)$ is corresponding to the luminance of the point X at Figure in Note (1).

Note 6 : Definition of contrast ratio:

Contrast ratio is calculated with the following formula.

$$\text{Contrast ratio (CR)} = \frac{\text{Brightness on the "White" state}}{\text{Brightness on the "Black" state}}$$

Note 7 : Definition of Cross Talk (CT)

$$CT = | Y_B - Y_A | / Y_A \times 100 (\%)$$

Where

Y_A = Luminance of measured location without gray level 0 pattern (cd/m²)

Y_B = Luminance of measured location with gray level 0 pattern (cd/m²)

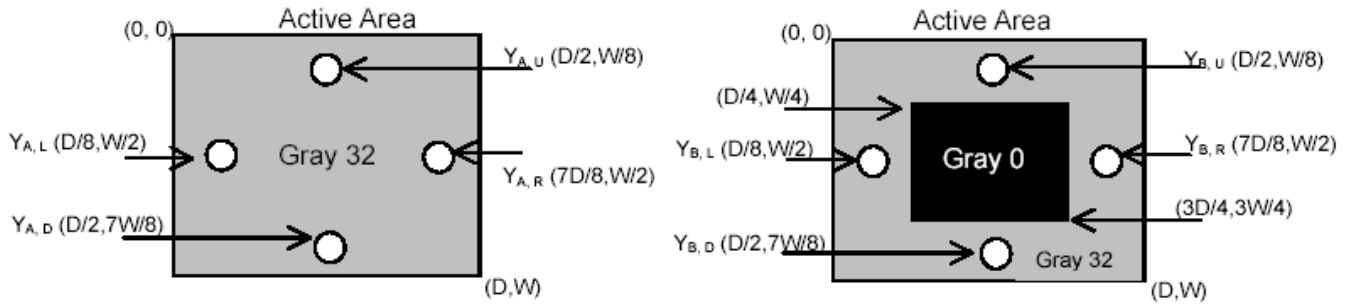

Note 8: Definition of response time:

The output signals of BM-7 or equivalent are measured when the input signals are changed from "Black" to "White" (falling time) and from "White" to "Black" (rising time), respectively. The response time interval between the 10% and 90% of amplitudes. Refer to figure as below.

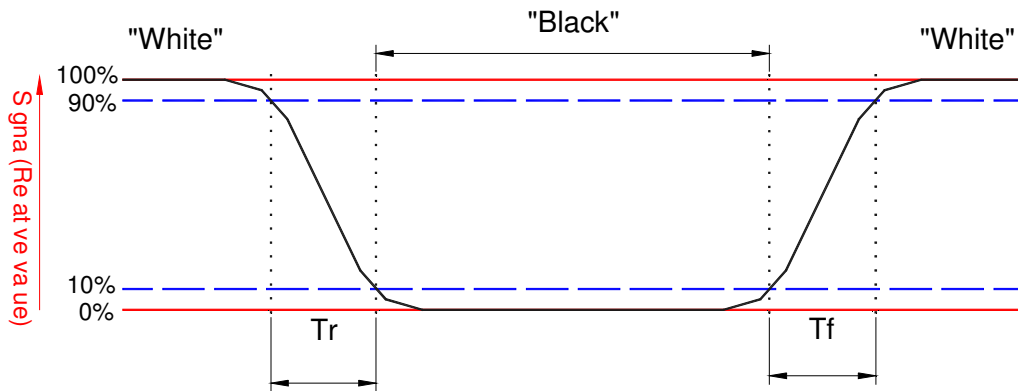

Note 9. Definition of viewing angle

Viewing angle is the measurement of contrast ratio ≥ 10 , at the screen center, over a 180° horizontal and 180° vertical range (off-normal viewing angles). The 180° viewing angle range is broken down as follows; 90° (θ) horizontal left and right and 90° (ϕ) vertical, high (up) and low (down). The measurement direction is typically perpendicular to the display surface with the screen rotated about its center to develop the desired measurement viewing angle.

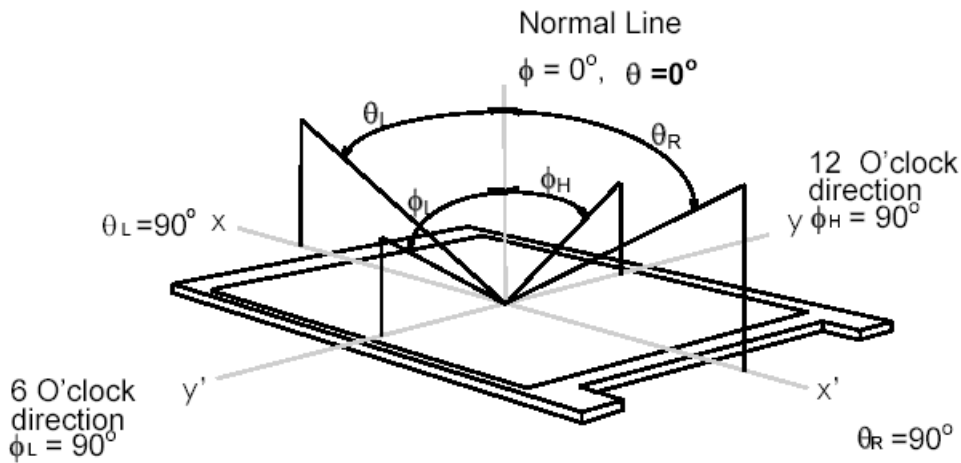

3. Functional Block Diagram

The following diagram shows the functional block of the 14.0 inches wide Color TFT/LCD 40 Pin one channel Module

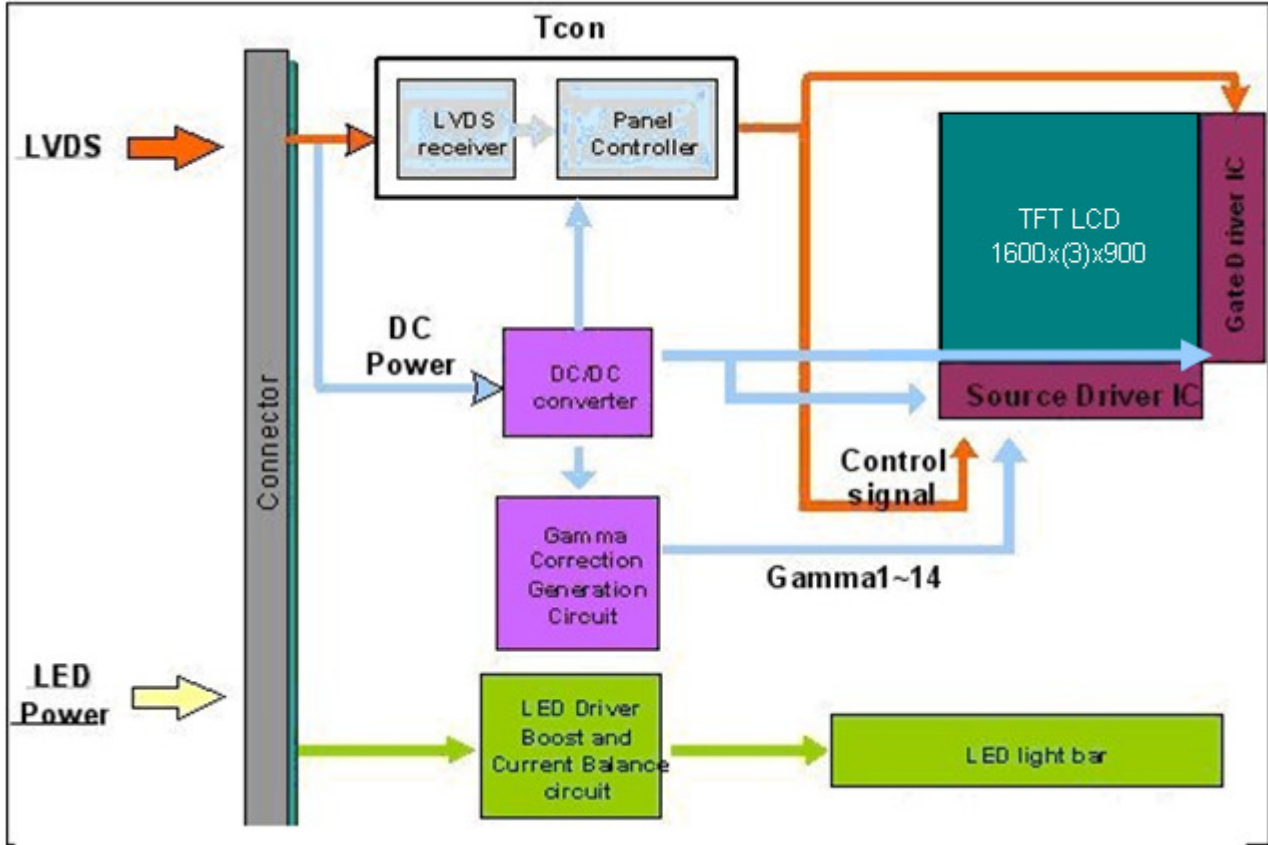

4. Absolute Maximum Ratings

An absolute maximum rating of the module is as following:

4.1 Absolute Ratings of TFT LCD Module

Item	Symbol	Min	Max	Unit	Conditions
Logic/LCD Drive Voltage	Vin	-0.3	+4.0	[Volt]	Note 1,2

4.2 Absolute Ratings of Environment

Item	Symbol	Min	Max	Unit	Conditions
Operating Temperature	TOP	0	+50	[°C]	Note 4
Operation Humidity	HOP	5	95	[%RH]	Note 4
Storage Temperature	TST	-20	+60	[°C]	Note 4
Storage Humidity	HST	5	95	[%RH]	Note 4

Note 1: At Ta (25°C)

Note 2: Permanent damage to the device may occur if exceed maximum values

Note 3: LED specification refer to section 5.2

Note 4: For quality performance, please refer to AUO IIS (Incoming Inspection Standard).

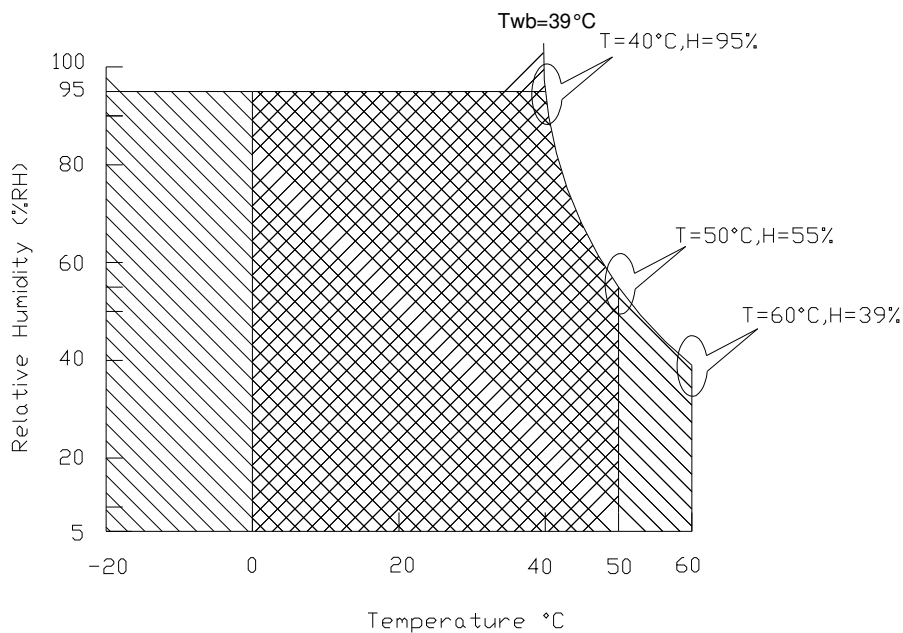

Operating Range 

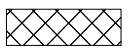
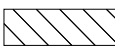
Storage Range  + 

5. Electrical Characteristics

5.1 TFT LCD Module

5.1.1 Power Specification

Input power specifications are as follows;

The power specification are measured under 25°C and frame frequency under 60Hz

Symble	Parameter	Min	Typ	Max	Units	Note
VDD	Logic/LCD Drive Voltage	3.0	3.3	3.6	[Volt]	
PDD	VDD Power	-	-	1.3	[Watt]	Note 1
IDD	IDD Current	-	-	0.43	[mA]	Note 1
IRush	Inrush Current	-	-	2000	[mA]	Note 2
VDDrp	Allowable Logic/LCD Drive Ripple Voltage	-	-	100	[mV] p-p	

Note 1 : Maximum Measurement Condition : Black Pattern at 3.3V driving voltage. ($P_{max} = V_{3.3} \times I_{black}$)

Note 2 : Measure Condition

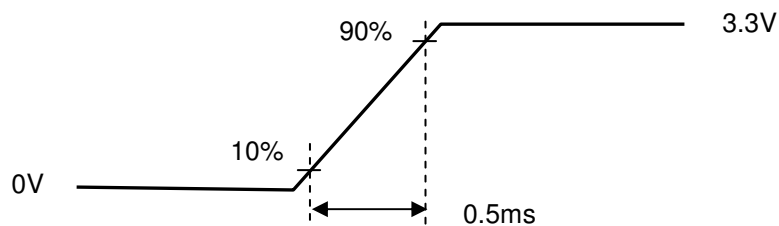
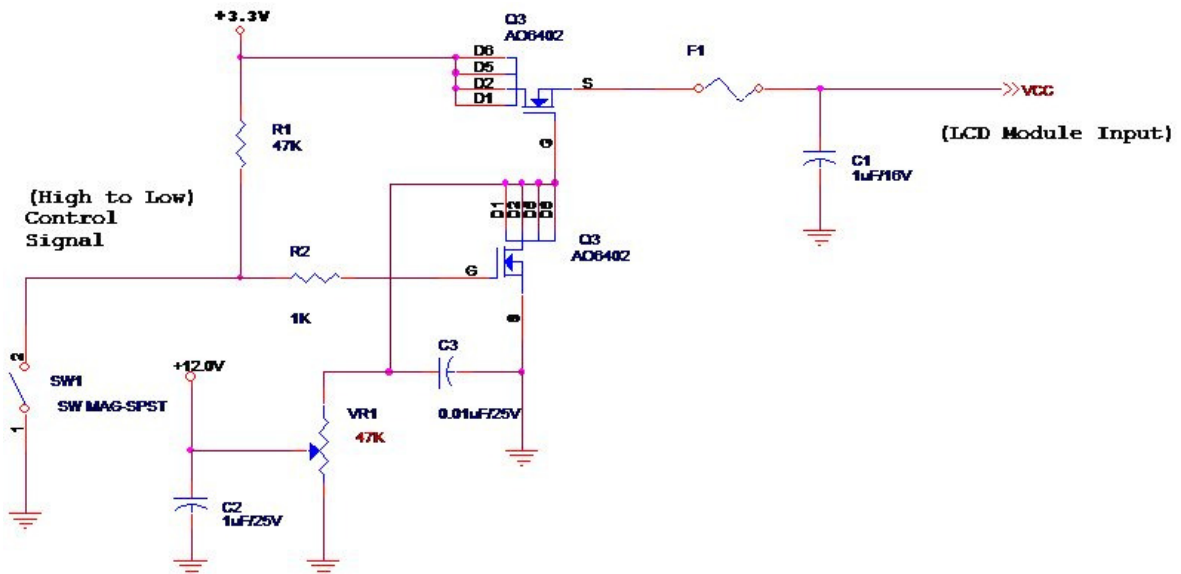

Vin rising time

5.1.2 Signal Electrical Characteristics

Signal electrical characteristics are as follows;

Parameter	Condition	Min	Max	Unit
V_{TH}	Differential Input High Threshold ($V_{cm}=+1.2V$)		100	[mV]
V_{TL}	Differential Input Low Threshold ($V_{cm}=+1.2V$)	-100	-	[mV]
V_{CM}	Differential Input Common Mode Voltage	1.125	1.375	[V]

Note: LVDS Signal Waveform

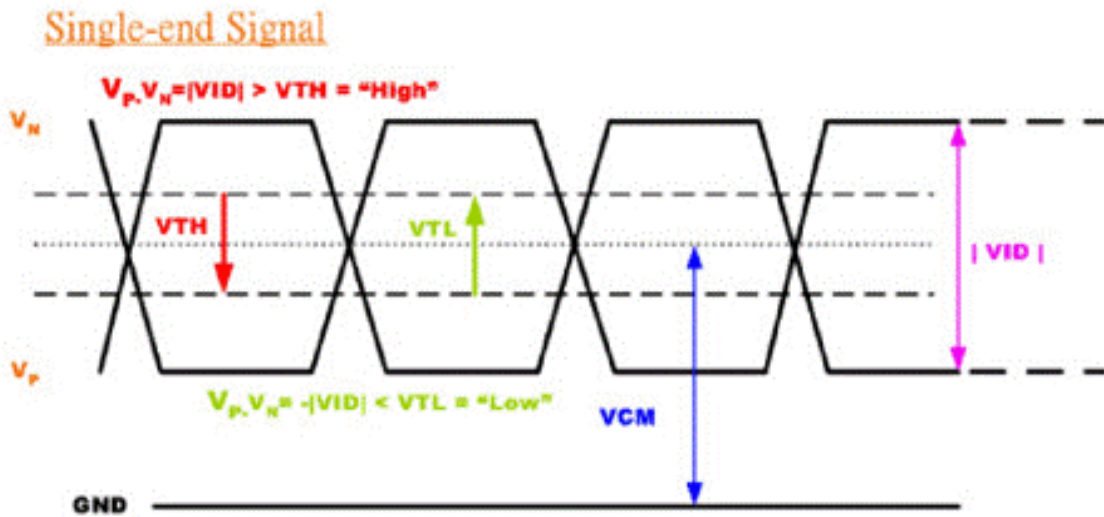

5.2 Backlight Unit

5.2.1 LED characteristics

Parameter	Symbol	Min	Typ	Max	Units	Condition
Backlight Power Consumption	PLED	-	-	4.5	[Watt]	(Ta=25°C), Note 1 Vin =12V
LED Life-Time	N/A	10000	-	-	Hour	(Ta=25°C), Note 2 If=20 mA

Note 1: Calculator value for reference $P_{LED} = V_F$ (Normal Distribution) * I_F (Normal Distribution) / Efficiency

Note 2: The LED life-time define as the estimated time to 50% degradation of initial luminous.

5.2.2 Backlight input signal characteristics

Parameter	Symbol	Min	Typ	Max	Units	Remark
LED Power Supply	VLED	6.0	12.0	21.0	[Volt]	Define as Connector Interface (Ta=25°C)
LED Enable Input High Level	VLED_EN	2.5	-	5.5	[Volt]	
LED Enable Input Low Level		-	-	0.8	[Volt]	
PWM Logic Input High Level	VPWM_EN	2.5	-	5.5	[Volt]	
PWM Logic Input Low Level		-	-	0.8	[Volt]	
PWM Input Frequency	FPWM	200	-	20K	Hz	
PWM Duty Ratio	Duty	5	--	100	%	

6. Signal Interface Characteristic

6.1 Pixel Format Image

Following figure shows the relationship of the input signals and LCD pixel format.

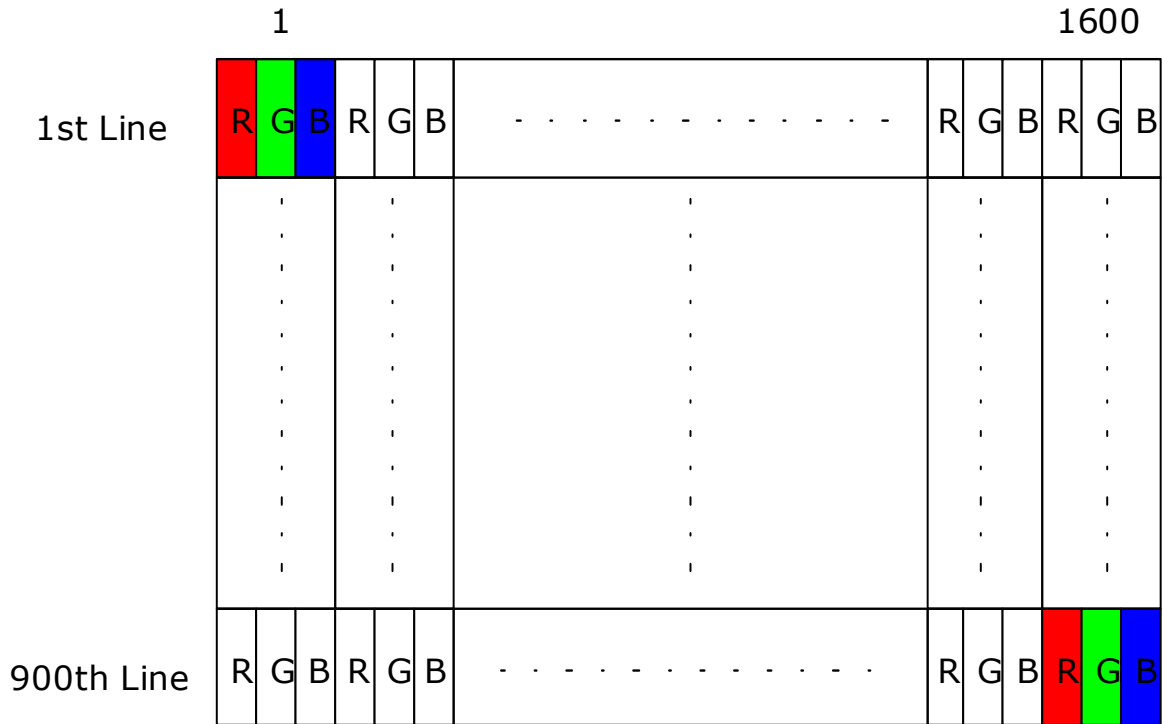

6.2 The Input Data Format





Product Specification

AU OPTRONICS CORPORATION

Signal Name	Description	
R5 R4 R3 R2 R1 R0	Red Data 5 (MSB) Red Data 4 Red Data 3 Red Data 2 Red Data 1 Red Data 0 (LSB) Red-pixel Data	Red-pixel Data Each red pixel's brightness data consists of these 6 bits pixel data.
G5 G4 G3 G2 G1 G0	Green Data 5 (MSB) Green Data 4 Green Data 3 Green Data 2 Green Data 1 Green Data 0 (LSB) Green-pixel Data	Green-pixel Data Each green pixel's brightness data consists of these 6 bits pixel data.
B5 B4 B3 B2 B1 B0	Blue Data 5 (MSB) Blue Data 4 Blue Data 3 Blue Data 2 Blue Data 1 Blue Data 0 (LSB) Blue-pixel Data	Blue-pixel Data Each blue pixel's brightness data consists of these 6 bits pixel data.
RxCLKIN	Data Clock	The signal is used to strobe the pixel data and DE signals. All pixel data shall be valid at the falling edge when the DE signal is high.
DE	Display Timing	This signal is strobed at the falling edge of RxCLKIN. When the signal is high, the pixel data shall be valid to be displayed.
VS	Vertical Sync	The signal is synchronized to RxCLKIN .
HS	Horizontal Sync	The signal is synchronized to RxCLKIN .

Note: Output signals from any system shall be low or High-impedance state when VDD is off.

6.3 Integration Interface Requirement

6.3.1 Connector Description

Physical interface is described as for the connector on module.

These connectors are capable of accommodating the following signals and will be following components.

Connector Name / Designation	For Signal Connector
Manufacturer	JAE or Compatible
Type / Part Number	JAE HD1S040HA1 or Compatible
Mating Housing/Part Number	I-PEX 20453-040T-12 or Compatible

6.3.2 Pin Assignment

LVDS is a differential signal technology for LCD interface and high speed data transfer device.

PIN #	SIGNAL NAME	DESCRIPTION
1	NC	NC
2	VDD	+ 3.3V Power Supply
3	VDD	+ 3.3V Power Supply
4	VEDID	+ 3.3V EDID Power
5	N.C	No Connect.
6	CLKEDID	EDID Clock Input
7	DATAEDID	EDID Data Input
8	Odd Rin0-	-LVDS Differential Data Input
9	Odd Rin0+	+LVDS Differential Data Input
10	VSS	Power Ground
11	Odd Rin1-	-LVDS Differential Data Input
12	Odd Rin1+	+LVDS Differential Data Input
13	VSS	Power Ground
14	Odd Rin2-	-LVDS Differential Data Input
15	Odd Rin2+	+LVDS Differential Data Input
16	VSS	Power Ground
17	Odd ClkIN-	-LVDS Differential Clock Input
18	Odd ClkIN+	+LVDS Differential Clock Input
19	VSS	Ground
20	Even Rin0-	-LVDS Differential Data Input
21	Even Rin0+	+LVDS Differential Data Input



Product Specification

AU OPTRONICS CORPORATION

22	VSS	Power Ground
23	Even_Rin1-	-LVDS Differential Data Input
24	Even_Rin1+	+LVDS Differential Data Input
25	VSS	Power Ground
26	Even_Rin2-	-LVDS Differential Data Input
27	Even_Rin2+	+LVDS Differential Data Input
28	VSS	Power Ground
29	Even_ClkIN-	-LVDS Differential Clock Input
30	Even_ClkIN+	+LVDS Differential Clock Input
31	VLED_GND	LED_GND
32	VLED_GND	LED_GND
33	VLED_GND	LED_GND
34	NC	NC
35	S-PWM	
36	LED_EN	
37	NC	NC
38	VLED	LED_Positive (6~21)
39	VLED	LED_Positive(6~21)
40	VLED	LED_Positive(6~21)

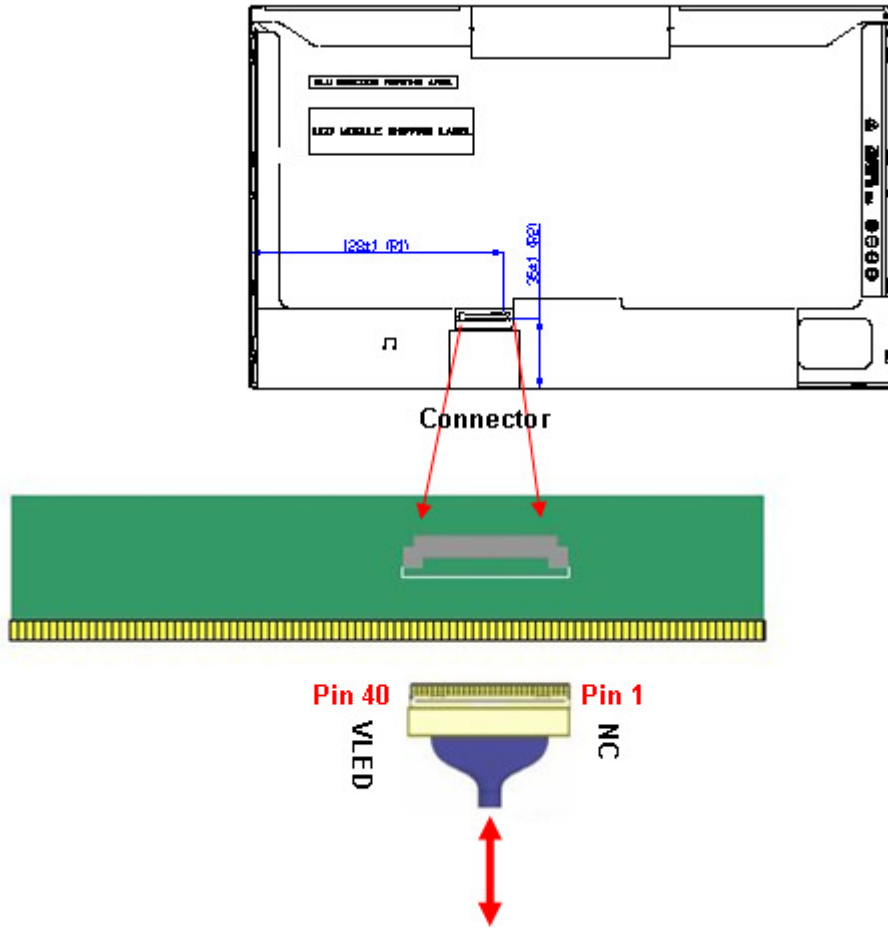

Note1: Input signals shall be low or High-impedance state when VDD is off.

6.4 Interface Timing

6.4.1 Timing Characteristics

Basically, interface timings should match the 1600x900 /60Hz manufacturing guide line timing.

Parameter	Symbol	Min.	Typ.	Max.	Unit	
Frame Rate	-		60		Hz	
Clock frequency	$1/T_{Clock}$		55		MHz	
Vertical Section	Period	T_V	908	912	2047	T_{Line}
	Active	T_{VD}	900			
	Blanking	T_{VB}	8	12	-	
Horizontal Section	Period	T_H	840	1006	2047	T_{Clock}
	Active	T_{HD}	800			
	Blanking	T_{HB}	40	206		

Note : DE mode only

6.4.2 Timing diagram

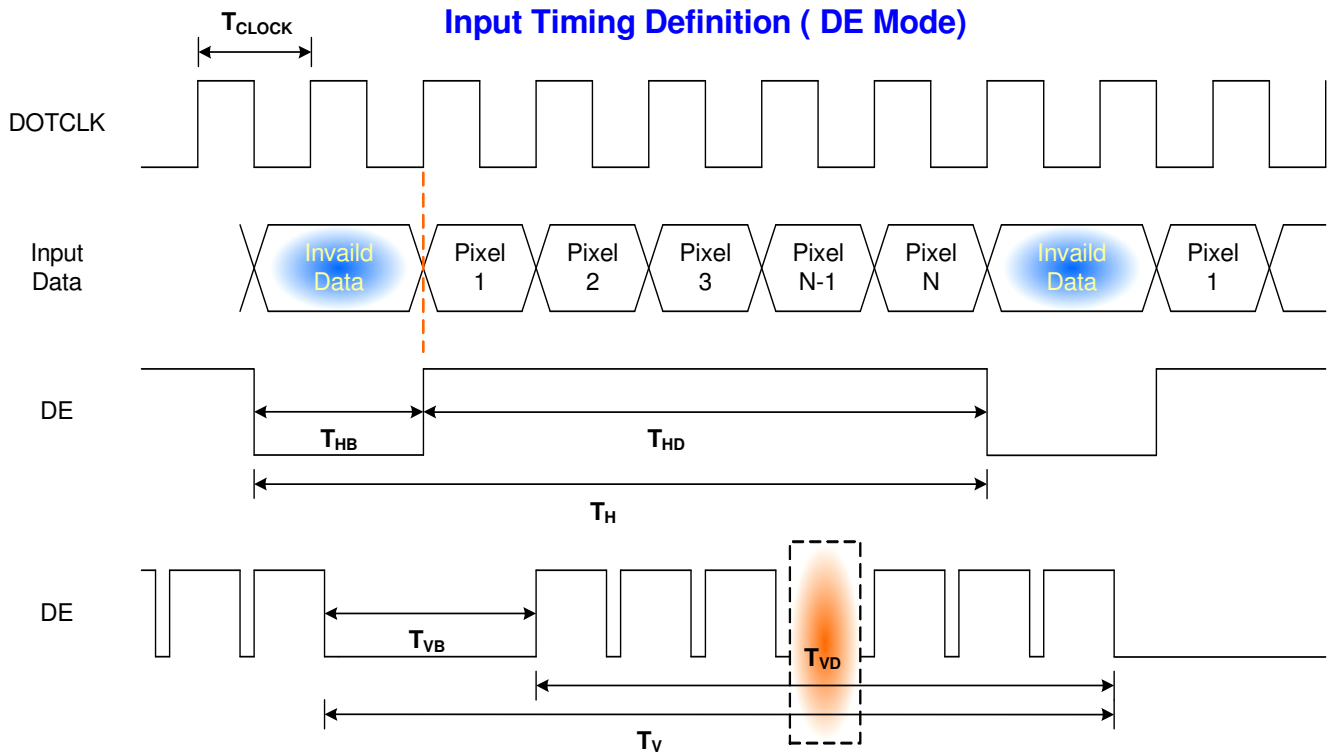

6.5 Power ON/OFF Sequence

VDD power on/off sequence is as follows. Interface signals are also shown in the chart. Signals from any system shall be Hi-Z state or low level when VDD is off

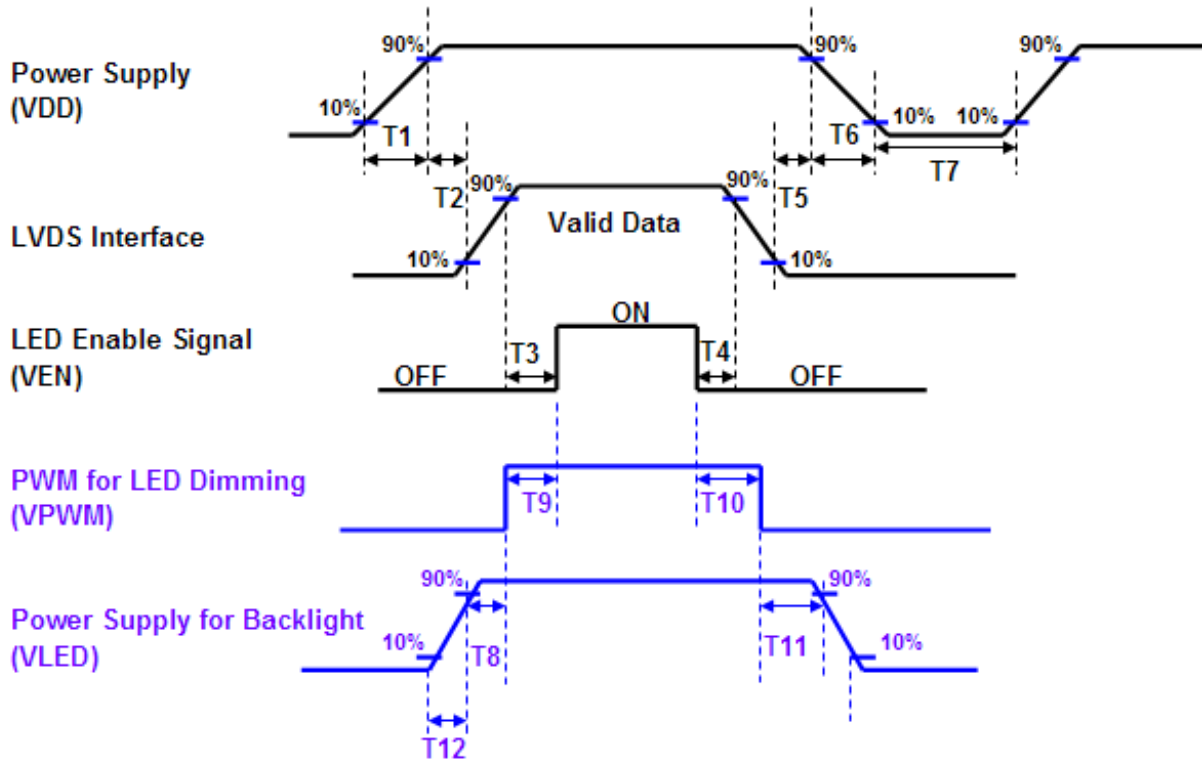

Power Sequence Timing			
Parameter	Value		Units
	Min.	Max.	
T1	0.5	10	ms
T2	0	50	
T3	250	-	
T4	200	-	
T5	0	50	
T6	0	10	
T7	500	-	
T8	10	-	
T9	10	180	
T10	10	180	
T11	10	-	
T12	0.5	10	

7. Panel Reliability Test

7.1 Vibration Test

Test Spec:

- Test method: Non-Operation
- Acceleration: 1.5 G
- Frequency: 10 - 500Hz Random
- Sweep: 30 Minutes each Axis (X, Y, Z)

7.2 Shock Test

Test Spec:

- Test method: Non-Operation
- Acceleration: 220 G , Half sine wave
- Active time: 2 ms
- Pulse: X,Y,Z .one time for each side

7.3 Reliability Test

Items	Required Condition	Note
Temperature Humidity Bias	Ta= 40°C, 90%RH, 300h	
High Temperature Operation	Ta= 50°C, Dry, 300h	
Low Temperature Operation	Ta= 0°C, 300h	
High Temperature Storage	Ta= 60°C, 35%RH, 300h	
Low Temperature Storage	Ta= -20°C, 50%RH, 250h	
Thermal Shock Test	Ta=-20°Cto 60°C, Duration at 30 min, 100 cycles	
ESD	Contact : ±8 KV Air : ±15 KV	Note 1

Note1: According to EN 61000-4-2 , ESD class B: Some performance degradation allowed. No data lost
 . Self-recoverable. No hardware failures.

Remark: MTBF (Excluding the LED): 30,000 hours with a confidence level 90%

8. Mechanical Characteristics

8.1 LCM Outline Dimension

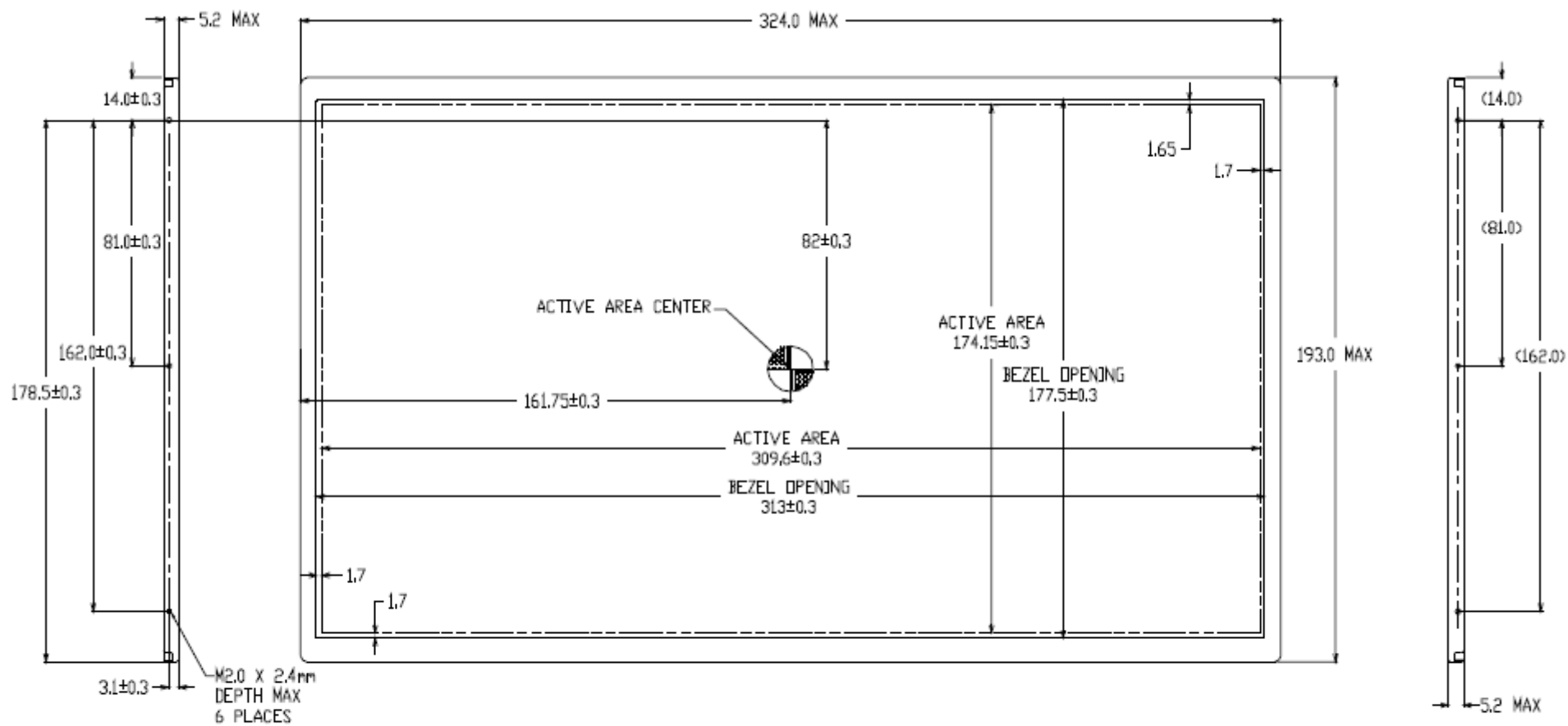

NOTE

1. 14.0" LCD module mechanical outline dimension
2. All dimension in mm
3. As viewed from front of LCD modules

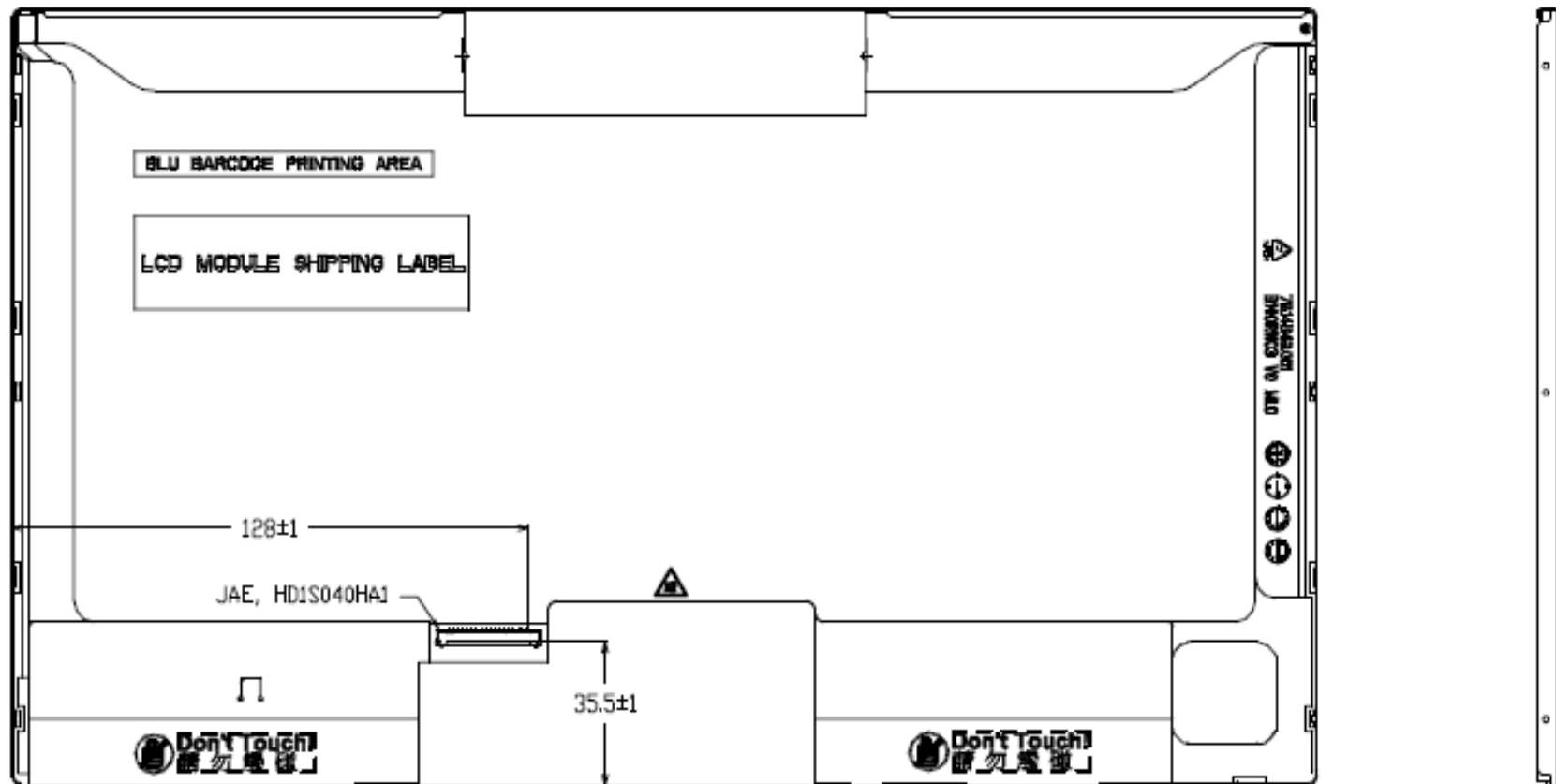

NOTE

1. 14.0" LCD module mechanical outline dimension
2. All dimension in mm
3. As viewed from back of LCD modules

Note: Prevention IC damage, IC positions not allowed any overlap over these areas

9. Shipping and Package

9.1 Shipping /Carton Label Format



9.2 Carton Package

The outside dimension of carton is 455 (L)mm x 380 (W)mm x 355 (H)mm

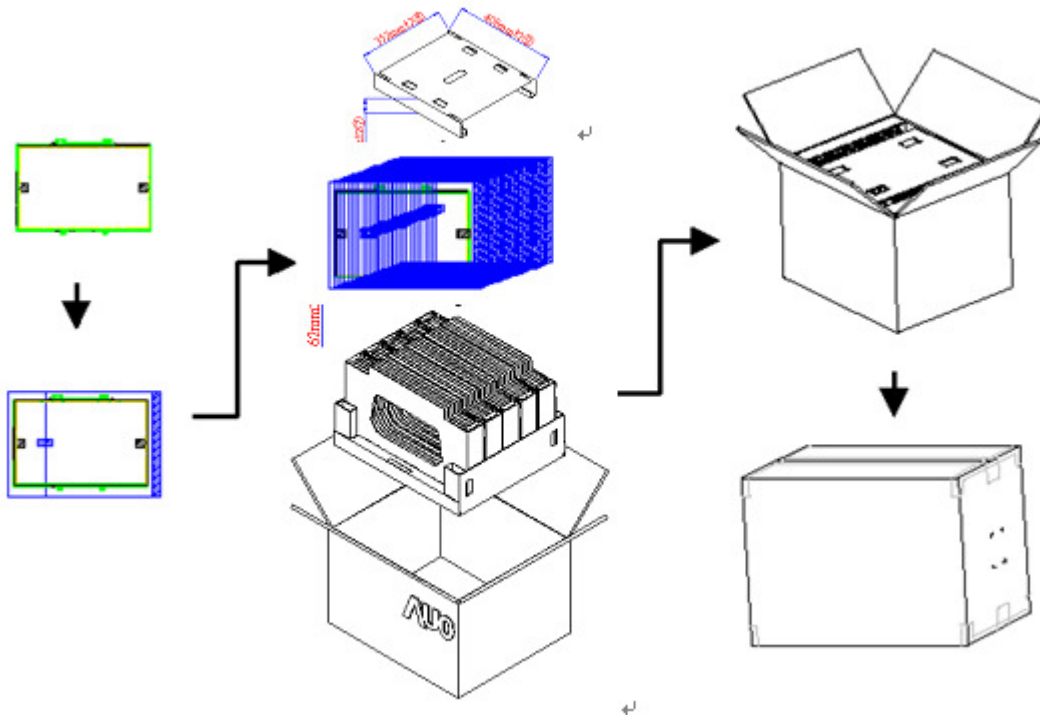

9.3 Shipping Package of Palletizing Sequence

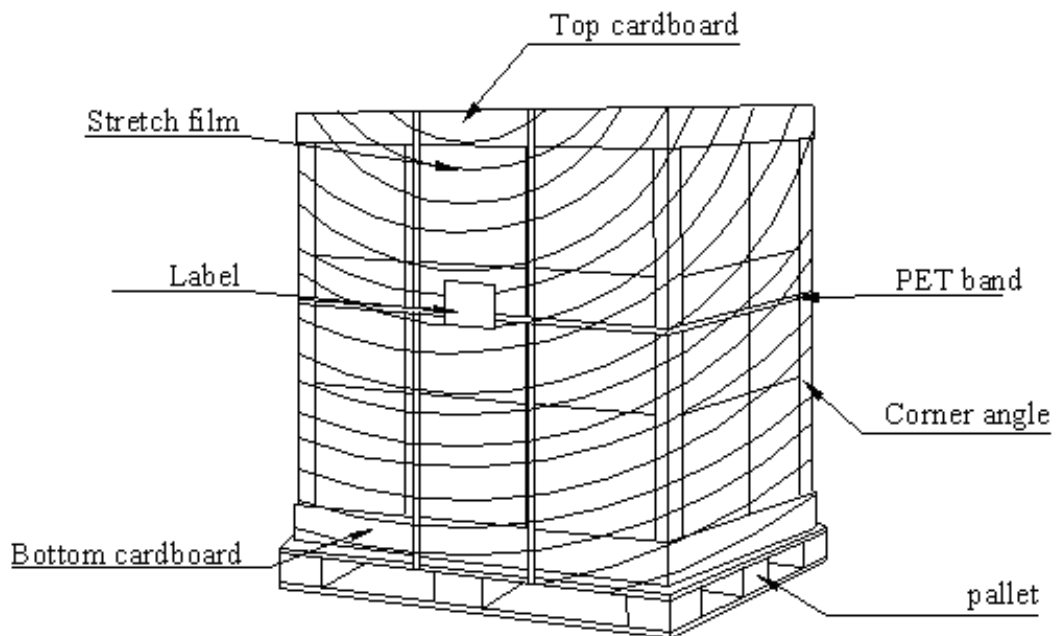

10. Appendix: EDID Description

Address	FUNCTION	Value	Value	Value	Note
HEX		HEX	BIN	DEC	
00	Header	00	00000000	0	
01		FF	11111111	255	
02		FF	11111111	255	
03		FF	11111111	255	
04		FF	11111111	255	
05		FF	11111111	255	
06		FF	11111111	255	
07		00	00000000	0	
08	EISA Manuf. Code LSB	06	00000110	6	
09	Compressed ASCII	AF	10101111	175	
0A	Product Code	3E	00111110	62	
0B	hex LSB first	31	00110001	49	
0C	32-bit ser #	00	00000000	0	
0D		00	00000000	0	
0E		00	00000000	0	
0F		00	00000000	0	
10	Week of manufacture	21	00100001	33	
11	Year of manufacture	14	00010100	20	
12	EDID Structure Ver.	01	00000001	1	
13	EDID revision #	04	00000100	4	
14	Video input def. (<i>digital I/P, non-TMDS, CRGB</i>)	90	10010000	144	
15	Max H image size (<i>rounded to cm</i>)	1F	00011111	31	
16	Max V image size (<i>rounded to cm</i>)	11	00010001	17	
17	Display Gamma (<i>=(gamma*100)-100</i>)	78	01111000	120	
18	Feature support (<i>no DPMS, Active OFF, RGB, tmg Blk#1</i>)	02	00000010	2	
19	Red/green low bits (Lower 2:2:2:2 bits)	CC	11001100	204	
1A	Blue/white low bits (Lower 2:2:2:2 bits)	CE	11001110	206	
1B	Red x (Upper 8 bits)	99	10011001	153	
1C	Red y/ highER 8 bits	58	01011000	88	
1D	Green x	50	01010000	80	
1E	Green y	8E	10001110	142	
1F	Blue x	26	00100110	38	
20	Blue y	24	00100100	36	
21	White x	4B	01001011	75	
22	White y	53	01010011	83	
23	Established timing 1	00	00000000	0	
24	Established timing 2	00	00000000	0	
25	Established timing 3	00	00000000	0	
26	Standard timing #1	01	00000001	1	
27		01	00000001	1	
28	Standard timing #2	01	00000001	1	
29		01	00000001	1	
2A	Standard timing #3	01	00000001	1	
2B		01	00000001	1	

2C	Standard timing #4	01	00000001	1	
2D		01	00000001	1	
2E	Standard timing #5	01	00000001	1	
2F		01	00000001	1	
30	Standard timing #6	01	00000001	1	
31		01	00000001	1	
32	Standard timing #7	01	00000001	1	
33		01	00000001	1	
34	Standard timing #8	01	00000001	1	
35		01	00000001	1	
36	Pixel Clock/10000 LSB	B0	10110000	176	
37	Pixel Clock/10000 USB	2C	00101100	44	
38	Horz active Lower 8bits	40	01000000	64	
39	Horz blanking Lower 8bits	CE	11001110	206	
3A	HorzAct:HorzBlnk Upper 4:4 bits	61	01100001	97	
3B	Vertical Active Lower 8bits	84	10000100	132	
3C	Vertical Blanking Lower 8bits	18	00011000	24	
3D	Vert Act : Vertical Blanking (upper 4:4 bit)	30	00110000	48	
3E	HorzSync. Offset	40	01000000	64	
3F	HorzSync.Width	2A	00101010	42	
40	VertSync.Offset : VertSync.Width	33	00110011	51	
41	Horz&Vert Sync Offset/Width Upper 2bits	00	00000000	0	
42	Horizontal Image Size Lower 8bits	35	00110101	53	
43	Vertical Image Size Lower 8bits	AE	10101110	174	
44	Horizontal & Vertical Image Size (upper 4:4 bits)	10	00010000	16	
45	Horizontal Border <i>(zero for internal LCD)</i>	00	00000000	0	
46	Vertical Border <i>(zero for internal LCD)</i>	00	00000000	0	
47	Signal <i>(non-intr, norm, no stero, sep sync, neg pol)</i>	18	00011000	24	
48	Detailed timing/monitor	CB	11001011	203	
49	descriptor #2	1D	00011101	29	
4A		40	01000000	64	
4B		CE	11001110	206	
4C		61	01100001	97	
4D		84	10000100	132	
4E		18	00011000	24	
4F		30	00110000	48	
50		40	01000000	64	
51		2A	00101010	42	
52		33	00110011	51	
53		00	00000000	0	
54		35	00110101	53	
55		AE	10101110	174	
56		10	00010000	16	
57		00	00000000	0	
58		00	00000000	0	
59		18	00011000	24	
5A	Detailed timing/monitor	00	00000000	0	
5B	descriptor #3	00	00000000	0	
5C		00	00000000	0	

5D		FE	11111110	254	
5E		00	00000000	0	
5F	Manufacture	41	01000001	65	A
60	Manufacture	55	01010101	85	U
61	Manufacture	4F	01001111	79	O
62		0A	00001010	10	
63		20	00100000	32	
64		20	00100000	32	
65		20	00100000	32	
66		20	00100000	32	
67		20	00100000	32	
68		20	00100000	32	
69		20	00100000	32	
6A		20	00100000	32	
6B		20	00100000	32	
6C	Detailed timing/monitor	00	00000000	0	
6D	descriptor #4	00	00000000	0	
6E		00	00000000	0	
6F		FE	11111110	254	
70		00	00000000	0	
71	Manufacture P/N	42	01000010	66	B
72	Manufacture P/N	31	00110001	49	1
73	Manufacture P/N	34	00110100	52	4
74	Manufacture P/N	30	00110000	48	0
75	Manufacture P/N	52	01010010	82	R
76	Manufacture P/N	57	01010111	87	W
77	Manufacture P/N	30	00110000	48	0
78	Manufacture P/N	33	00110011	51	3
79	Manufacture P/N	20	00100000	32	
7A	Manufacture P/N	56	01010110	86	V
7B	Manufacture P/N	31	00110001	49	1
7C		20	00100000	32	
7D		0A	00001010	10	
7E	Extension Flag	00	00000000	0	
7F	Checksum	C4	11000100	196	
SUM				7680	