



Product Specification

AU OPTRONICS CORPORATION

B141EW03 VB (QD14TL01 Rev.04)

() Preliminary Specifications

(V) Final Specifications

Module	14.1" WXGA Color TFT-LCD
Model Name	B141EW03 VB (QD14TL01 REV.04)

Customer	Date
_____	_____
Checked & Approved by	
_____	_____
<p>Note: This Specification is subject to change without notice.</p>	

Approved by	Date
_____	_____
Prepared by	
<i>Beyond Yang</i>	1/10/2007
<p>MDBU Marketing Division / AU Optronics corporation</p>	



Contents

1. Handling Precautions	4
2. General Description	5
2.1 Display Characteristics	5
2.2 Optical Characteristics	6
3. Functional Block Diagram	11
4. Absolute Maximum Ratings	12
4.1 TFT LCD Module.....	12
4.2 Backlight Unit.....	12
4.3 Absolute Ratings of Environment	12
5. Electrical characteristics	13
5.1 TFT LCD Module.....	13
5.2 Backlight Unit.....	15
6. Signal Characteristic	17
6.1 Pixel Format Image.....	17
6.2 The input data format.....	18
6.3 Signal Description	19
6.4 Interface Timing	21
6.5 Power ON/OFF Sequence	22
7. Connector & Pin Assignment	23
7.1 TFT LCD Module.....	23
7.2 Backlight Unit.....	23
7.3 Signal for Lamp connector	23
8. Vibration and Shock Test	24
8.1 Vibration Test	24
8.2 Shock Test Spec:	24
9. Reliability	25
10. Mechanical Characteristics	26
10.1 LCM Outline Dimension	26
10.2 Screw Hole Depth and Center Position.....	28
11. Shipping and Package	29
11.1 Shipping Label Format	29
11.2. Carton package.....	30
11.3 Shipping package of palletizing sequence	30
12. Appendix: EDID description	31



Product Specification

AU OPTRONICS CORPORATION

B141EW03 VB (QD14TL01 Rev.04)

Record of Revision

Version and Date	Page	Old description	New Description	Remark
0.1 2006/12/14	All	First Edition for Customer		
1.0 2007/1/10		Preliminary version	Final version	



1. Handling Precautions

- 1) Since front polarizer is easily damaged, pay attention not to scratch it.
- 2) Be sure to turn off power supply when inserting or disconnecting from input connector.
- 3) Wipe off water drop immediately. Long contact with water may cause discoloration or spots.
- 4) When the panel surface is soiled, wipe it with absorbent cotton or other soft cloth.
- 5) Since the panel is made of glass, it may break or crack if dropped or bumped on hard surface.
- 6) Since CMOS LSI is used in this module, take care of static electricity and insure human earth when handling.
- 7) Do not open nor modify the Module Assembly.
- 8) Do not press the reflector sheet at the back of the module to any directions.
- 9) In case if a Module has to be put back into the packing container slot after once it was taken out from the container, do not press the center of the CCFL Reflector edge. Instead, press at the far ends of the CFL Reflector edge softly. Otherwise the TFT Module may be damaged.
- 10) At the insertion or removal of the Signal Interface Connector, be sure not to rotate nor tilt the Interface Connector of the TFT Module.
- 11) After installation of the TFT Module into an enclosure (Notebook PC Bezel, for example), do not twist nor bend the TFT Module even momentary. At designing the enclosure, it should be taken into consideration that no bending/twisting forces are applied to the TFT Module from outside. Otherwise the TFT Module may be damaged.
- 12) Cold cathode fluorescent lamp in LCD contains a small amount of mercury. Please follow local ordinances or regulations for disposal.
- 13) Small amount of materials having no flammability grade is used in the LCD module. The LCD module should be supplied by power complied with requirements of Limited Power Source (, IEC60950 or UL1950), or be applied exemption.
- 14) The LCD module is designed so that the CCFL in it is supplied by Limited Current Circuit (IEC60950 or UL1950). Do not connect the CCFL in Hazardous Voltage Circuit.



Product Specification

AU OPTRONICS CORPORATION

B141EW03 VB (QD14TL01 Rev.04)

2. General Description

B141EW03 VB(QD14TL01 REV.04) is a Color Active Matrix Liquid Crystal Display composed of a TFT LCD panel, a driver circuit, and backlight system. The screen format is intended to support the WXGA (1280(H) x 800(V)) screen and 262k colors (RGB 6-bits data driver). All input signals are LVDS interface compatible. Inverter of backlight is not included.

B141EW03 VB(QD14TL01 REV.04) is designed for a display unit of notebook style personal computer and industrial machine.

2.1 General Specification

The following items are characteristics summary on the table at 25 °C condition:

Items	Unit	Specifications
Screen Diagonal	[mm]	358.1 (14.1 W")
Active Area	[mm]	303.74 (H) x 189.84 (V)
Pixels H x V		1280 x 800
Pixel Pitch	[mm]	0.2373 x 0.2373
Pixel Arrangement		R.G.B. Vertical Stripe
Display Mode		Normally White
White Luminance (I _{CCFL} =6.0mA) Note: I _{CCFL} is lamp current	[cd/m ²]	220 typ. (5 points average) 190 min. (5 points average) (Note1)
Luminance Uniformity		1.25 max. (5 points)
Contrast Ratio		400 typ /300 min.,
Optical Rise Time/Fall Time	[msec]	25 typ.
Nominal Input Voltage VDD	[Volt]	+3.3 typ.
Power Consumption	[Watt]	5.7 max.(without inverter)
Weight	[Grams]	440 max(without inverter)
Physical Size	[mm]	320 max. (W) x 206 max. (H) x 5.5 max.
Electrical Interface		1 channel LVDS
Surface Treatment		Anitglare (AG45%), Hardness 3H,
Support Color		262K colors (RGB 6-bit)
Temperature Range Operating Storage (Non-Operating)	[°C] [°C]	0 to +50 -20 to +60
RoHS Compliance		RoHS Compliance



Product Specification

AU OPTRONICS CORPORATION

B141EW03 VB (QD14TL01 Rev.04)

2.2 Optical Characteristics

The optical characteristics are measured under stable conditions at 25°C (Room Temperature):

Item	Unit	Conditions	Min.	Typ.	Max.	Note
White Luminance I _{CCFL} =6.0mA	[cd/m ²]	5 points average	190	220	-	1, 4, 5.
Viewing Angle	[degree]	Horizontal (Right)	40	45	-	8
	[degree]	CR = 10 (Left)	40	45	-	
	[degree]	Vertical (Upper)	10	25	-	
	[degree]	CR = 10 (Lower)	30	35	-	
Luminance Uniformity		5 Points			1.25	1
Luminance Uniformity		13 Points			1.61	2
CR: Contrast Ratio			300	400	-	6
Cross talk	%				4	7
Response Time	[msec]	Rising	-	8	10	8
	[msec]	Falling	-	16	25	
	[msec]	Rising + Falling		25	35	
Color / Chromaticity Coordinates (CIE 1931)		Red x	0.545	0.575	0.605	2,8
		Red y	0.295	0.325	0.355	
		Green x	0.280	0.310	0.340	
		Green y	0.525	0.555	0.585	
		Blue x	0.125	0.155	0.185	
		Blue y	0.115	0.145	0.175	
		White x	0.283	0.313	0.343	
		White y	0.299	0.329	0.359	

Note 1: 5 points position (Display area : 303.74 (H) x 189.84 (V)mm)

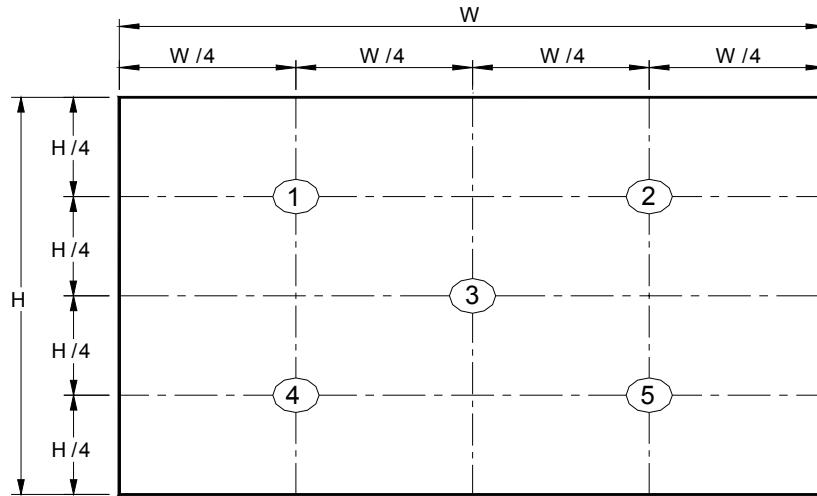

Note 2: 13 points position

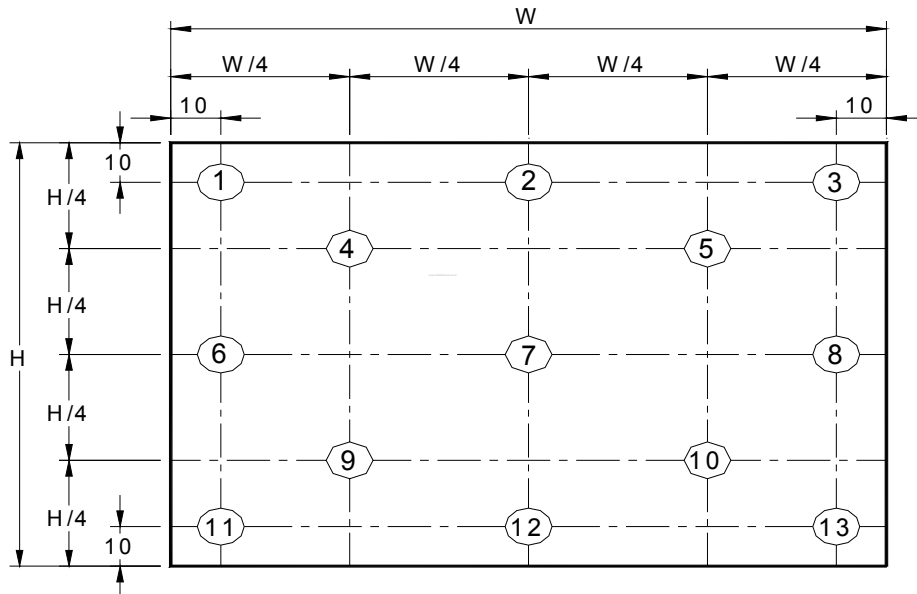

Note 3: The luminance uniformity of 5 and 13 points is defined by dividing the maximum luminance values by the minimum test point luminance

$$\delta_{W5} = \frac{\text{Maximum Brightness of five points}}{\text{Minimum Brightness of five points}}$$

$$\delta_{W13} = \frac{\text{Maximum Brightness of thirteen points}}{\text{Minimum Brightness of thirteen points}}$$

Note 4: Measurement method

The LCD module should be stabilized at given temperature for 30 minutes to avoid abrupt temperature change during measuring. In order to stabilize the luminance, the measurement should be executed after lighting Backlight for 30 minutes in a stable, windless and dark room.

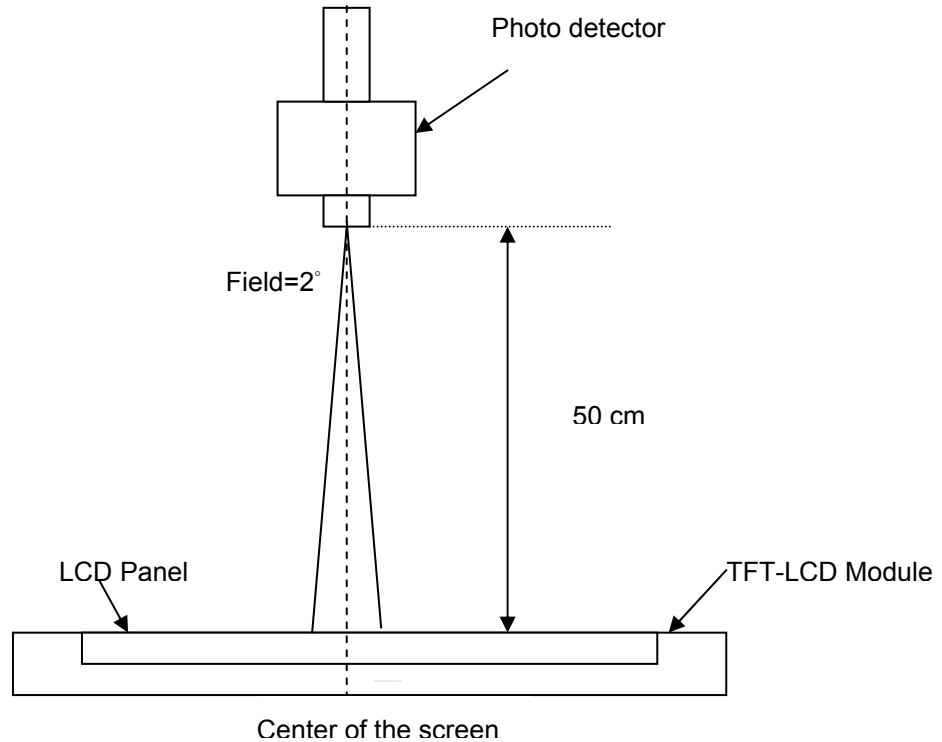

Note 5 : Definition of Average Luminance of White (Y_L):

Measure the luminance of gray level 63 at 5 points , $Y_L = [L (1)+ L (2)+ L (3)+ L (4)+ L (5)] / 5$

$L (x)$ is corresponding to the luminance of the point X at Figure in Note (1).

Note 6 : Definition of contrast ratio:

Contrast ratio is calculated with the following formula.

$$\text{Contrast ratio (CR)} = \frac{\text{Brightness on the "White" state}}{\text{Brightness on the "Black" state}}$$

Note 7 : Definition of Cross Talk (CT)

$$CT = | Y_B - Y_A | / Y_A \times 100 (\%)$$

Where

Y_A = Luminance of measured location without gray level 0 pattern (cd/m²)

Y_B = Luminance of measured location with gray level 0 pattern (cd/m²)

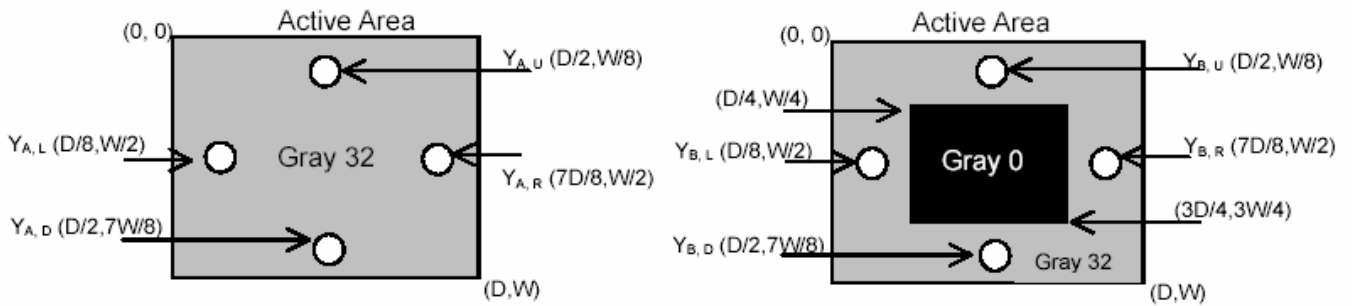

Note 8: Definition of response time:

The output signals of BM-7 or equivalent are measured when the input signals are changed from "Black" to "White" (falling time) and from "White" to "Black" (rising time), respectively. The response time interval between the 10% and 90% of amplitudes. Refer to figure as below.

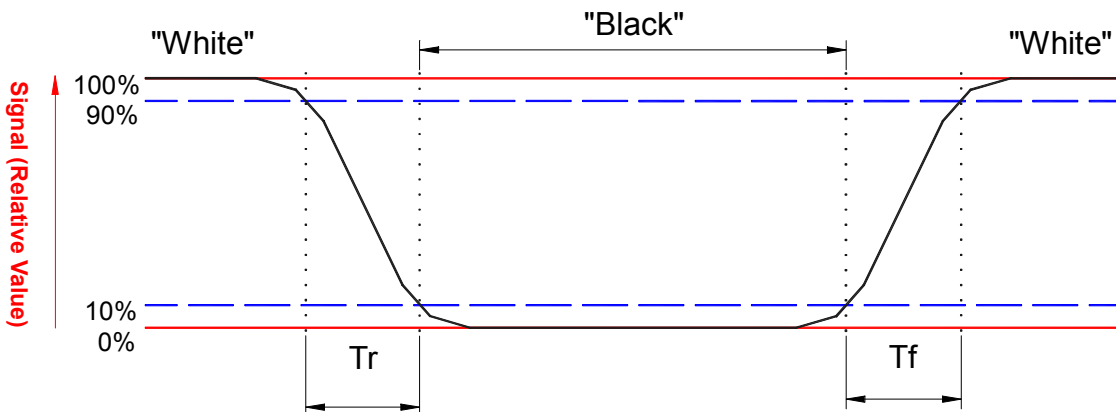

Note 8. Definition of viewing angle

Viewing angle is the measurement of contrast ratio ≥ 10 , at the screen center, over a 180° horizontal and 180° vertical range (off-normal viewing angles). The 180° viewing angle range is broken down as follows; 90° (θ) horizontal left and right and 90° (Φ) vertical, high (up) and low (down). The measurement direction is typically perpendicular to the display surface with the screen rotated about its center to develop the desired measurement viewing angle.

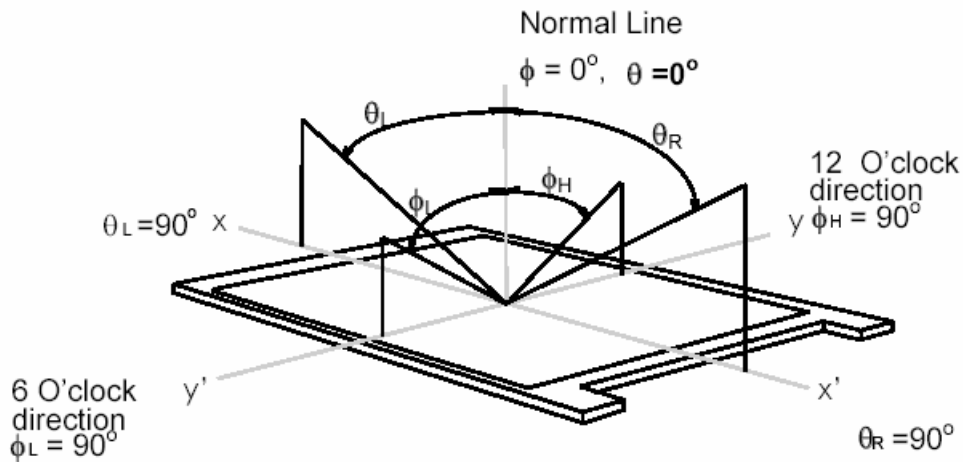

3. Functional Block Diagram

The following diagram shows the functional block of the 14.1 inches wide Color TFT/LCD Module:

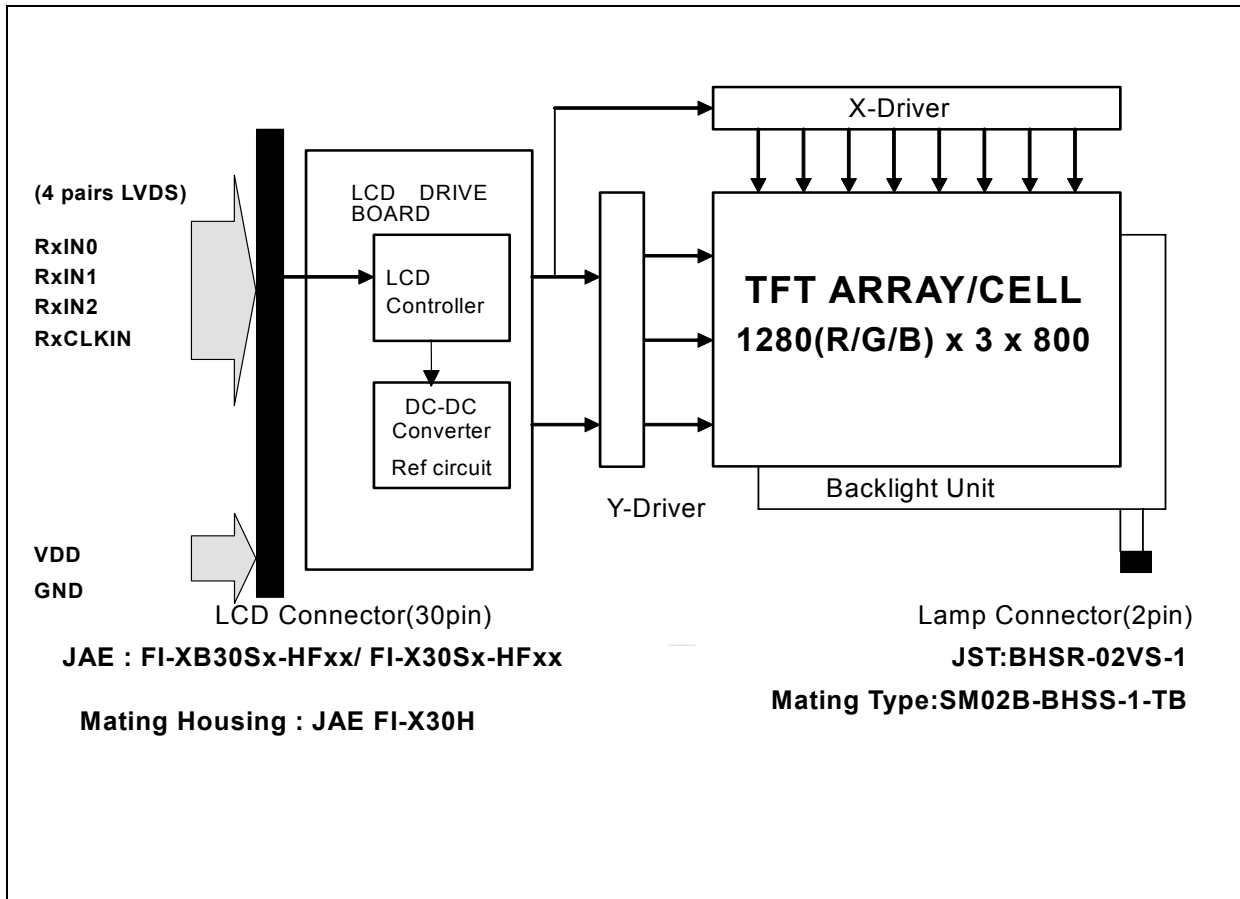

4. Absolute Maximum Ratings

Absolute maximum ratings of the module is as following:

4.1 Absolute Ratings of TFT LCD Module

Item	Symbol	Min	Max	Unit	Conditions
Logic/LCD Drive Voltage	Vin	3	+3.6	[Volt]	Note 1,2

4.2 Absolute Ratings of Backlight Unit

Item	Symbol	Min	Max	Unit	Conditions
CCFL Current	ICCFL	2.0	6.5	[mA] rms	Note 1,2

4.3 Absolute Ratings of Environment

Item	Symbol	Min	Max	Unit	Conditions
Operating Temperature	TOP	0	+50	[°C]	Note 3
Operation Humidity	HOP	5	95	[%RH]	Note 3
Storage Temperature	TST	-20	+65	[°C]	Note 3
Storage Humidity	HST	5	95	[%RH]	Note 3

Note 1: At Ta (25°C)

Note 2: Permanent damage to the device may occur if exceed maximum values

Note 3: For quality performance, please refer to AUO IIS(Incoming Inspection Standard).

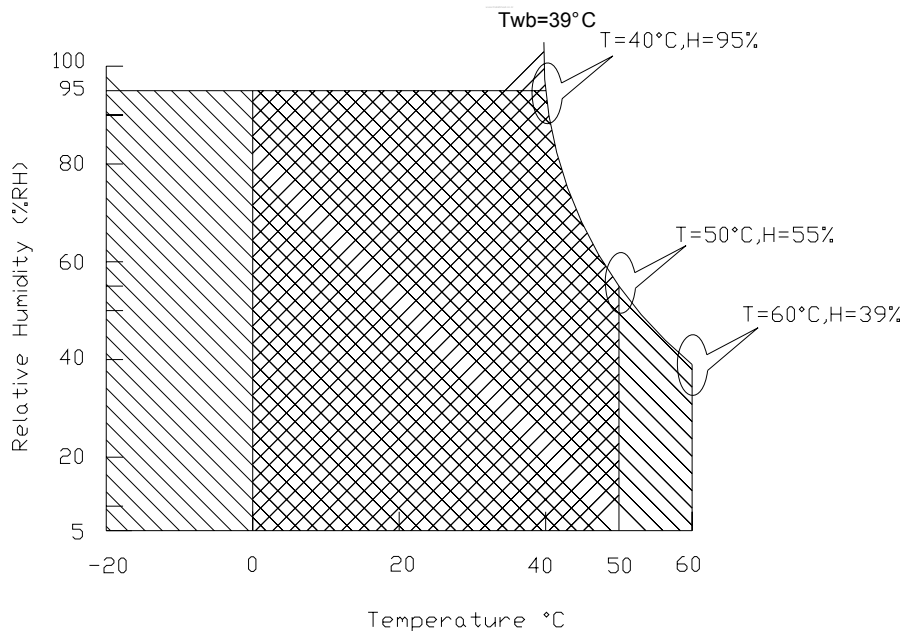

Operating Range



Storage Range

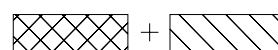

5. Electrical characteristics

5.1 TFT LCD Module

5.1.1 Power Specification

Input power specifications are as follows;

Symble	Parameter	Min	Typ	Max	Units	Note
VDD	Logic/LCD Drive Voltage	3.0	3.3	3.6	[Volt]	
PDD	VDD Power			1.5	[Watt]	Note 1
IDD	IDD Current		400	450	[mA]	Note 1
IRush	Inrush Current			1500	[mA]	Note 2
VDDrp	Allowable Logic/LCD Drive Ripple Voltage			100	[mV] p-p	

Note 1 : Maximum Measurement Condition : Black Pattern

Note 2 : Measure Condition

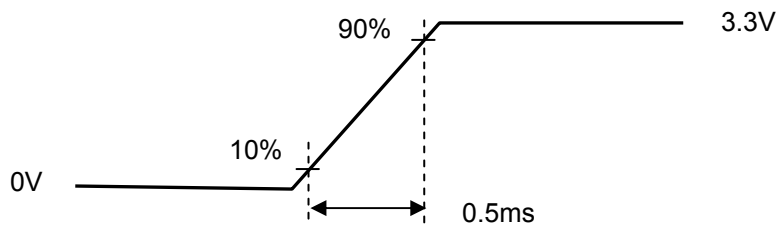
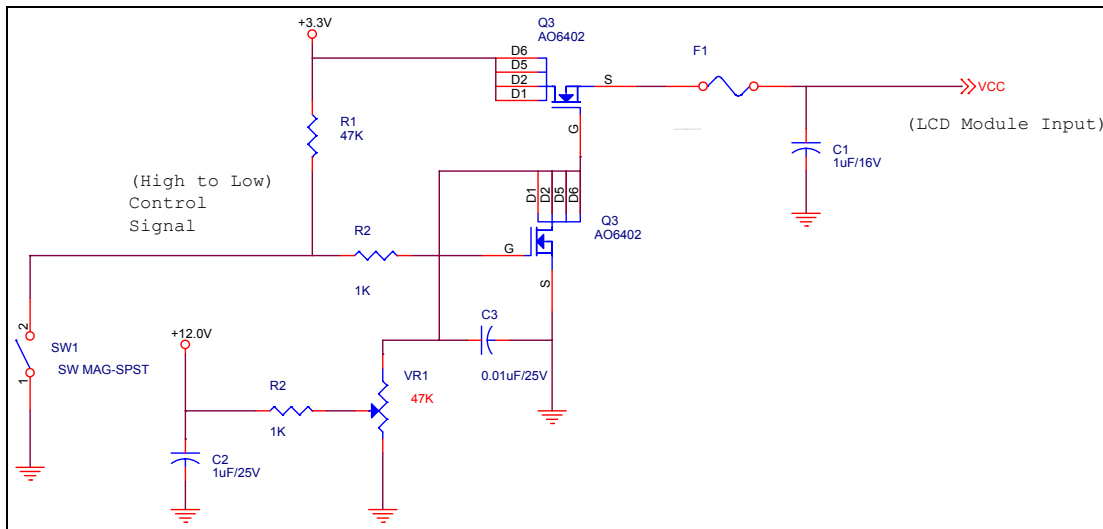

Vin rising time

5.1.2 Signal Electrical Characteristics

Input signals shall be low or High-impedance state when VDD is off.

Signal electrical characteristics are as follows;

Parameter	Condition	Min	Max	Unit
Vth	Differential Input High Threshold (Vcm=+1.2V)		100	[mV]
Vtl	Differential Input Low Threshold (Vcm=+1.2V)	-100		[mV]
Vcm	Differential Input Common Mode Voltage	1.0	1.5	[V]

Note: LVDS Differential Voltage

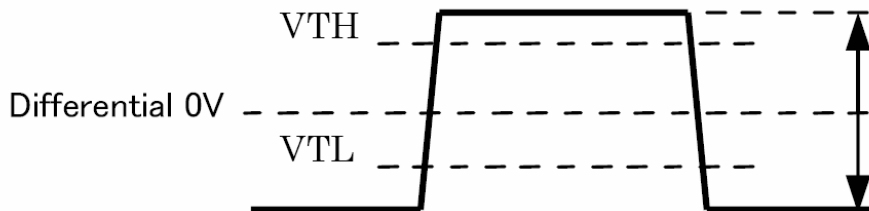

5.2 Backlight Unit

Parameter guideline for CCFL Inverter

Parameter	Min	Typ	Max	Units	Condition
White Luminance 5 points average	190	200	-	[cd/m ²]	(Ta=25°C)
CCFL current(I _{CCFL})	2.0	6.0	6.5	[mA] rms	(Ta=25°C) Note 2
CCFL Frequency(F _{CCFL})	50		80	[KHz]	(Ta=25°C) Note 3,4
CCFL Ignition Voltage(V _s)			1500	[Volt] rms	(Ta= 0°C) Note 5
CCFL Ignition Voltage(V _s)			1060	[Volt] rms	(Ta= 25°C) Note 5
CCFL discharge time(sec)	1				(Ta= 25°C) Note 1
CCFL Voltage (Reference) (V _{CCFL})	589	655	721	[Volt] rms	(Ta=25°C) Note 6
CCFL Power consumption (P _{CCFL})	3.54	3.93	4.32	[Watt]	(Ta=25°C) Note 6

Note 1: Typ are AUO recommended Design Points.

*1 All of characteristics listed are measured under the condition using the AUO Test inverter.

*2 In case of using an inverter other than listed, it is recommended to check the inverter carefully.

Sometimes, interfering noise stripes appear on the screen, and substandard luminance or flicker at low power may happen.

*3 In designing an inverter, it is suggested to check safety circuit very carefully. Impedance of CCFL, for instance, becomes more than 1 [M ohm] when CFL is damaged.

*4 Generally, CCFL has some amount of delay time after applying kick-off voltage. It is recommended to keep on applying kick-off voltage for 1 [Sec] until discharge.

*5 CCFL discharge frequency must be carefully chosen so as not to produce interfering noise stripes on the screen.

*6 Reducing CCFL current increases CCFL discharge voltage and generally increases CCFL discharge frequency. So all the parameters of an inverter should be carefully designed so as not to produce too much leakage current from high-voltage output of the inverter.

Note 2: It should be employed the inverter which has "Duty Dimming", if ICCFL is less than 4mA.

Note 3: CCFL discharge frequency should be carefully determined to avoid interference between inverter and TFT LCD.

Note 4: The frequency range will not affect to lamp life and reliability characteristics.

Note 5: CCFL inverter should be able to give out a power that has a generating capacity of over 1,430 voltage. Lamp units need 1,400 voltage minimum for ignition.

Note 6: Calculator value for reference ($I_{CCFL} \times V_{CCFL} = P_{CCFL}$)

Note 7: Requirements for a system inverter design, which is intended to have a better display performance, a better power efficiency and a more reliable lamp, are following.

It shall help increase the lamp lifetime and reduce leakage current.

- a. The asymmetry rate of the inverter waveform should be less than 10%.
- b. The distortion rate of the waveform should be within $\sqrt{2} \pm 10\%$.

* Inverter output waveform had better be more similar to ideal sine wave.

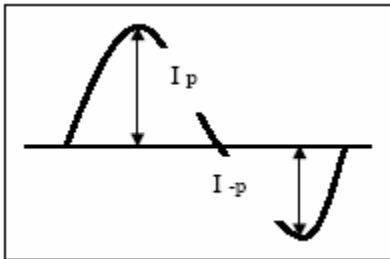

* Asymmetry rate:

$$\frac{|I_p - I_{-p}|}{I_{rms}} * 100\%$$

* Distortion rate

$$I_p \text{ (or } I_{-p}) / I_{rms}$$

6. Signal Characteristic

6.1 Pixel Format Image

Following figure shows the relationship of the input signals and LCD pixel format.

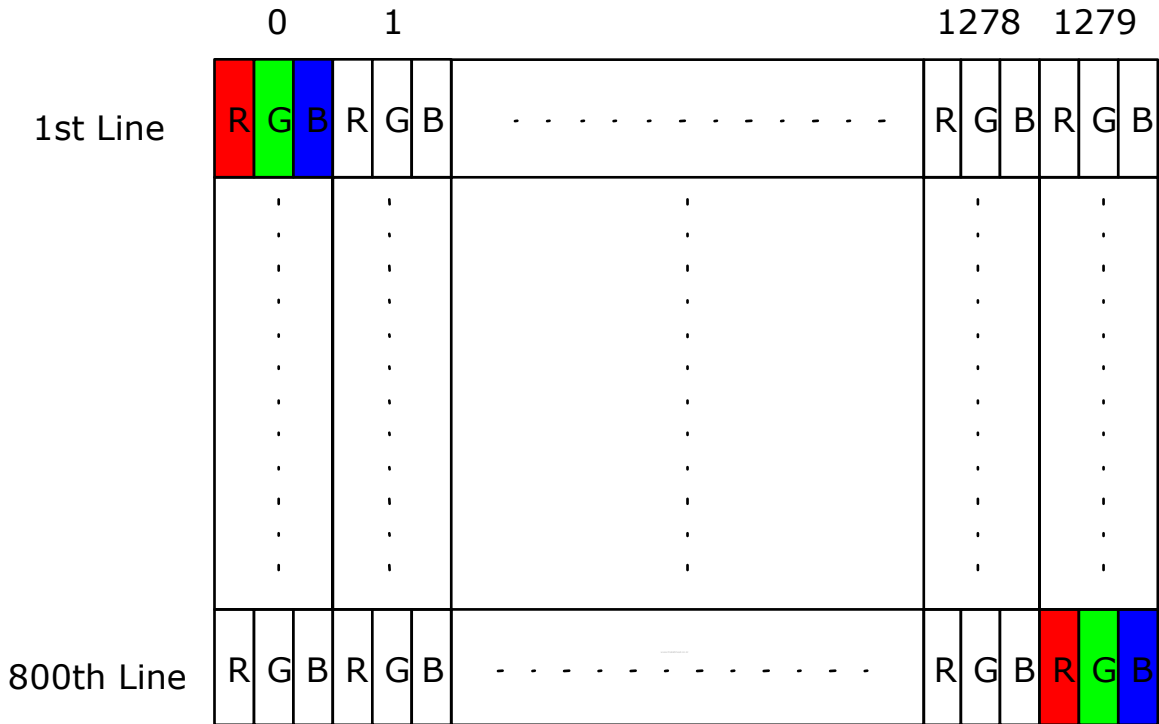

6.2 The input data format

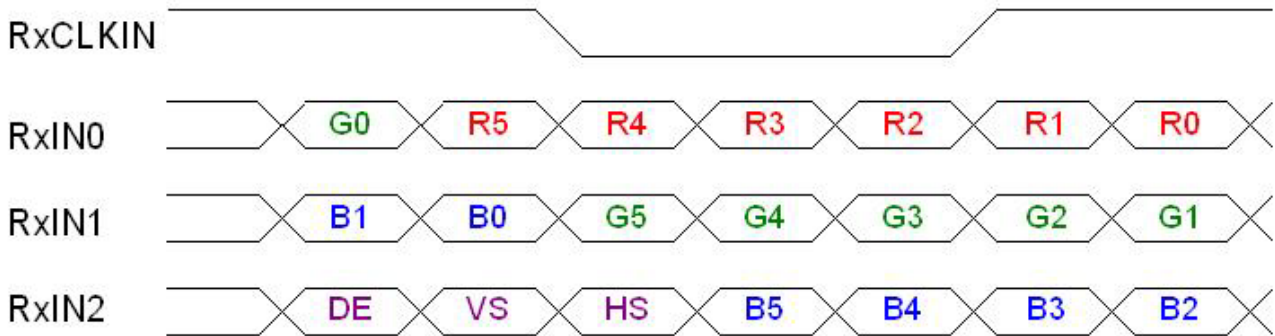

Signal Name	Description	
R5 R4 R3 R2 R1 R0	Red Data 5 (MSB) Red Data 4 Red Data 3 Red Data 2 Red Data 1 Red Data 0 (LSB) Red-pixel Data	Red-pixel Data Each red pixel's brightness data consists of these 6 bits pixel data.
G5 G4 G3 G2 G1 G0	Green Data 5 (MSB) Green Data 4 Green Data 3 Green Data 2 Green Data 1 Green Data 0 (LSB) Green-pixel Data	Green-pixel Data Each green pixel's brightness data consists of these 6 bits pixel data.
B5 B4 B3 B2 B1 B0	Blue Data 5 (MSB) Blue Data 4 Blue Data 3 Blue Data 2 Blue Data 1 Blue Data 0 (LSB) Blue-pixel Data	Blue-pixel Data Each blue pixel's brightness data consists of these 6 bits pixel data.
RxCLKIN	Data Clock	The typical frequency is 68.9 MHz. The signal is used to strobe the pixel data and DE signals. All pixel data shall be valid at the falling edge when the DE signal is high.
DE	Display Timing	This signal is strobed at the falling edge of RxCLKIN. When the signal is high, the pixel data shall be valid to be displayed.
VS	Vertical Sync	The signal is synchronized to RxCLKIN.
HS	Horizontal Sync	The signal is synchronized to RxCLKIN.

Note: Output signals from any system shall be low or High-impedance state when VDD is off.



Product Specification

AU OPTRONICS CORPORATION

B141EW03 VB (QD14TL01 Rev.04)

6.3 Signal Description/Pin Assignment

LVDS is a differential signal technology for LCD interface and high speed data transfer device.

PIN#	Signal Name	Description
1	GND	Ground
2	VDD	+3.3V Power Supply
3	VDD	+3.3V Power Supply
4	V _{EDID}	+3.3V EDID Power
5	NC	No Connection (Reserve for AUO test)
6	CLK _{EDID}	EDID Clock Input
7	DATA _{EDID}	EDID Data Input
8	RxIN0-	LVDS differential data input(R0-R5, G0)
9	RxIN0+	LVDS differential data input(R0-R5, G0)
10	GND	Ground
11	RxIN1-	LVDS differential data input(G1-G5, B0-B1)
12	RxIN1+	LVDS differential data input(G1-G5, B0-B1)
13	GND	Ground
14	RxIN2-	LVDS differential data input(B2-B5, HS, VS, DE)
15	RxIN2+	LVDS differential data input(B2-B5, HS, VS, DE)
16	GND	Ground
17	RxCLKIN-	LVDS differential clock input
18	RxCLKIN+	LVDS differential clock input
19	GND	Ground
20	NC	No Connection (Reserve for AUO test)
21	NC	No Connection (Reserve for AUO test)
22	GND	Ground
23	NC	No Connection (Reserve for AUO test)
24	NC	No Connection (Reserve for AUO test)
25	GND	Ground
26	NC	No Connection (Reserve for AUO test)
27	NC	No Connection (Reserve for AUO test)
28	NC	No Connection (Reserve for AUO test)
29	NC	No Connection (Reserve for AUO test)
30	NC	No Connection (Reserve for AUO test)

Note1: Start from right side (must change)

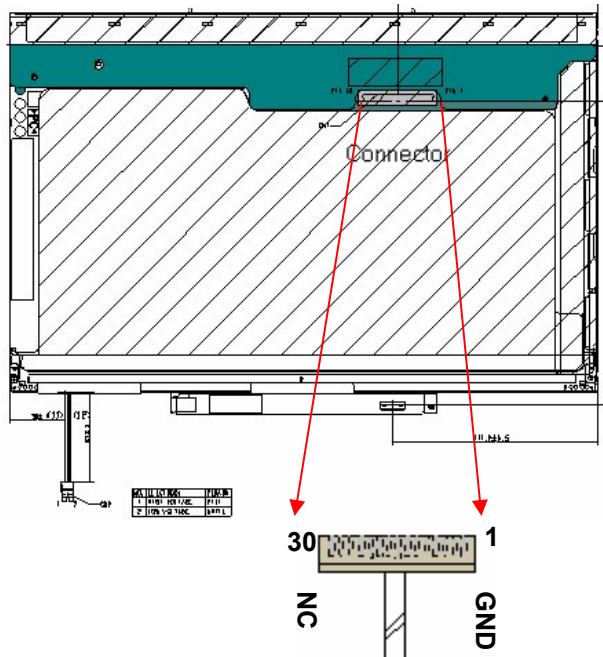

Note2: Input signals shall be low or High-impedance state when VDD is off.
internal circuit of LVDS inputs are as following.

The module uses a 100ohm resistor between positive and negative data lines of each receiver input

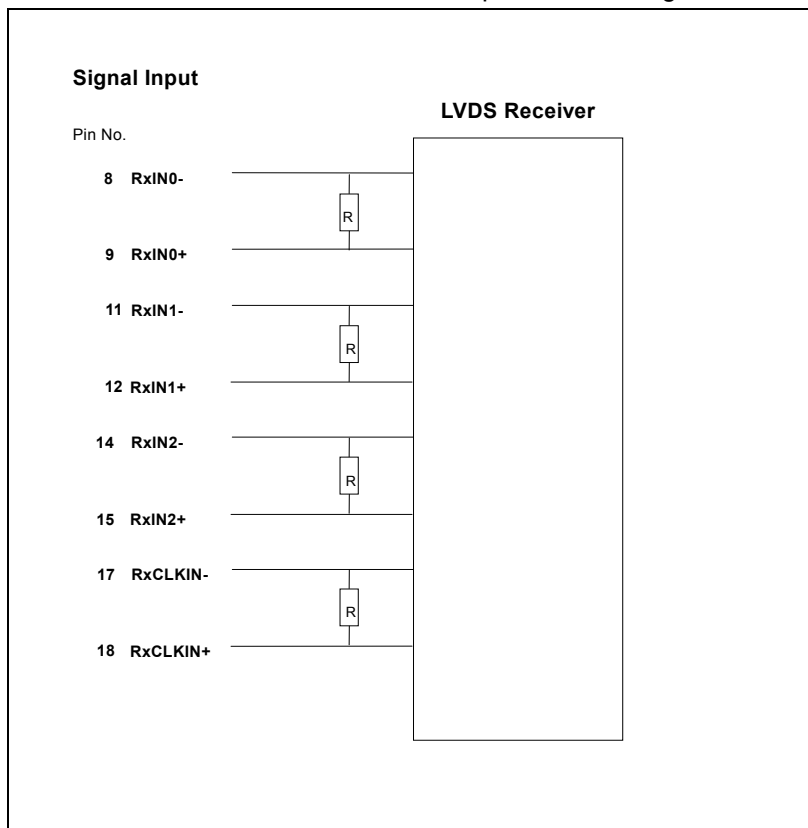

6.4 Interface Timing

6.4.1 Timing Characteristics

Basically, interface timings should match the 1280x800 /60Hz manufacturing guide line timing.

Parameter	Symbol	Min.	Typ.	Max.	Unit	
Frame Rate	-	50	60	-	Hz	
Clock frequency	$1/T_{Clock}$	50	68.9	80	MHz	
Vertical Section	Period	T_V	808	816	832	T_{Line}
	Active	T_{VD}	800	800	800	
	Blanking	T_{VB}	8	16	32	
Horizontal Section	Period	T_H	1302	1408	1700	T_{Clock}
	Active	T_{HD}	1280	1280	1280	
	Blanking	T_{HB}	22	128	420	

Note : DE mode only

6.4.2 Timing diagram

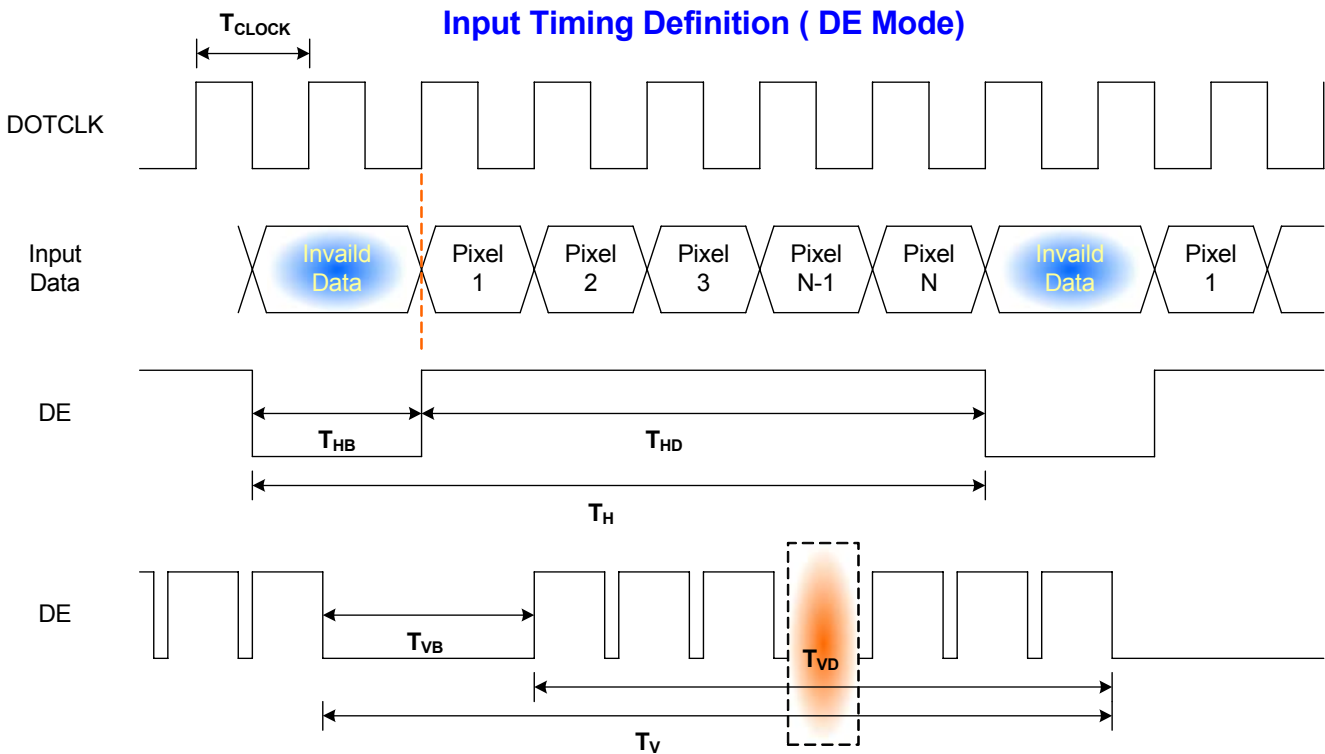

6.5 Power ON/OFF Sequence

VDD power and lamp on/off sequence is as follows. Interface signals are also shown in the chart. Signals from any system shall be Hi-Z state or low level when VDD is off.

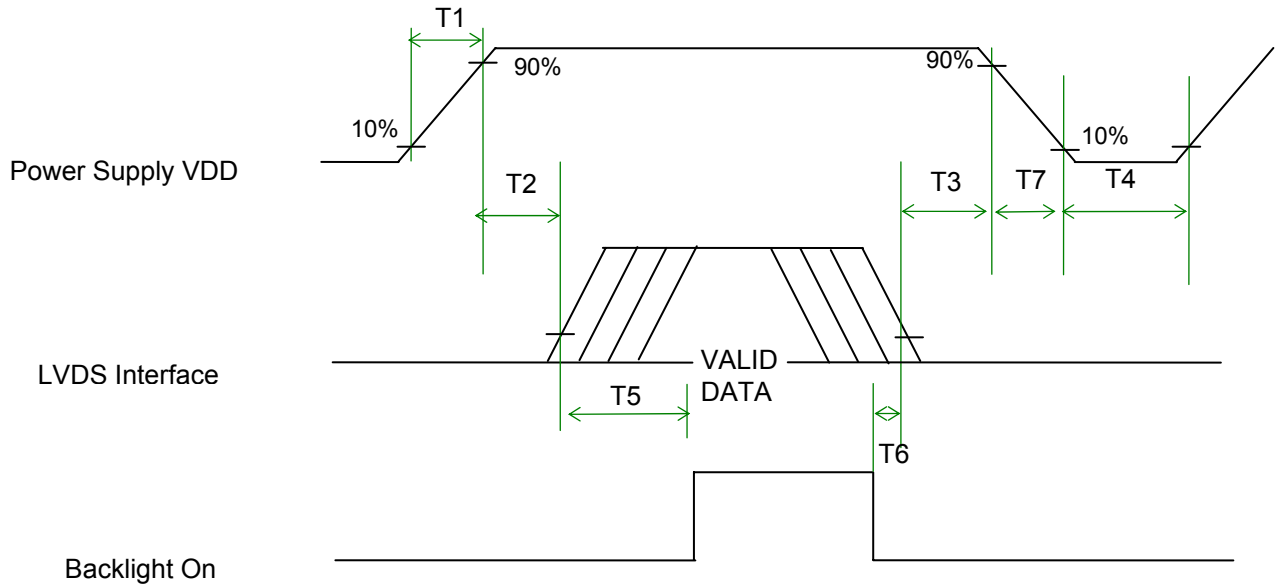

Power Sequence Timing

Parameter	Value			Units
	Min.	Typ.	Max.	
T1	0.5	-	10	(ms)
T2	0	-	50	(ms)
T3	0	-	50	(ms)
T4	400	-	-	(ms)
T5	200	-	-	(ms)
T6	200	-	-	(ms)
T7	0	-	10	(ms)



Product Specification

AU OPTRONICS CORPORATION

B141EW03 VB (QD14TL01 Rev.04)

7. Connector Description

Physical interface is described as for the connector on module.

These connectors are capable of accommodating the following signals and will be following components.

7.1 TFT LCD Module

Connector Name / Designation	For Signal Connector
Manufacturer	JAE or compatible
Type / Part Number	FI-XB30Sx-HFxx/ FI-X30Sx-HFxx or compatible
Mating Housing/Part Number	FI-X30H or compatible

7.2 Backlight Unit

Physical interface is described as for the connector on module.

These connectors are capable of accommodating the following signals and will be following components.

Connector Name / Designation	For Lamp Connector
Manufacturer	JST
Type / Part Number	BHSR-02VS-1
Mating Type / Part Number	SM02B-BHSS-1-TB

7.3 Signal for Lamp connector

Pin #	Cable color	Signal Name
1	Red	Lamp High Voltage
2	White	Lamp Low Voltage



8. Vibration and Shock Test

8.1 Vibration Test

Test Spec:

- Test method: Non-Operation
- Acceleration: 1.5G , sine wave
- Frequency: 10 - 500Hz
- Sweep: 30 Minutes each Axis (X, Y, Z)

8.2 Shock Test Spec:

Test Spec:

- Test method: Non-Operation
- Acceleration: 220 G , Half sine wave
- Active time: 2 ms
- Pulse: X,Y,Z .one time for each side



Product Specification

AU OPTRONICS CORPORATION

B141EW03 VB (QD14TL01 Rev.04)

9. Reliability

Items	Required Condition	Note
Temperature Humidity Bias	40°C/90%,300Hr	
High Temperature Operation	50°C/Dry,300Hr	
Low Temperature Operation	0°C,300Hr	
On/Off Test	25°C, 150hrs(ON/10 sec. OFF/10sec., 10,000 cycles)	
Hot Storage	60°C/35% RH ,250 hours	
Cold Storage	-20°C/50% RH ,250 hours	
Thermal Shock Test	-20°C/30 min ,60°C/30 min 100cycles	
Hot Start Test	50°C/1 Hr min. power on/off per 5 minutes, 5 times	
Cold Start Test	0°C/1 Hr min. power on/off per 5 minutes, 5 times	
Shock Test (Non-Operating)	220G, 2ms, Half-sine wave, 1 time for $\pm x$, $\pm y$, $\pm z$ 6 directions	
Vibration Test (Non-Operating)	Sine-wave Vibration, 1.5 G zero-to-peak, 10 to 500 Hz, 30 mins in each of three mutually perpendicular axes.	
ESD	Contact : $\pm 8KV$ / operation Air : $\pm 15KV$ / operation	Note 1
Room temperature Test	25°C, 2000hours, Operating with loop pattern	

Note1: According to EN61000-4-2 , ESD class B: Some performance degradation allowed. No data lost . Self-recoverable. No hardware failures.

Note2: CCFL Life time: 10,000 hours minimum under normal module usage.

Note3: MTBF (Excluding the CCFL): 30,000 hours with a confidence level 90%



Product Specification

AU OPTRONICS CORPORATION

B141EW03 VB (QD14TL01 Rev.04)

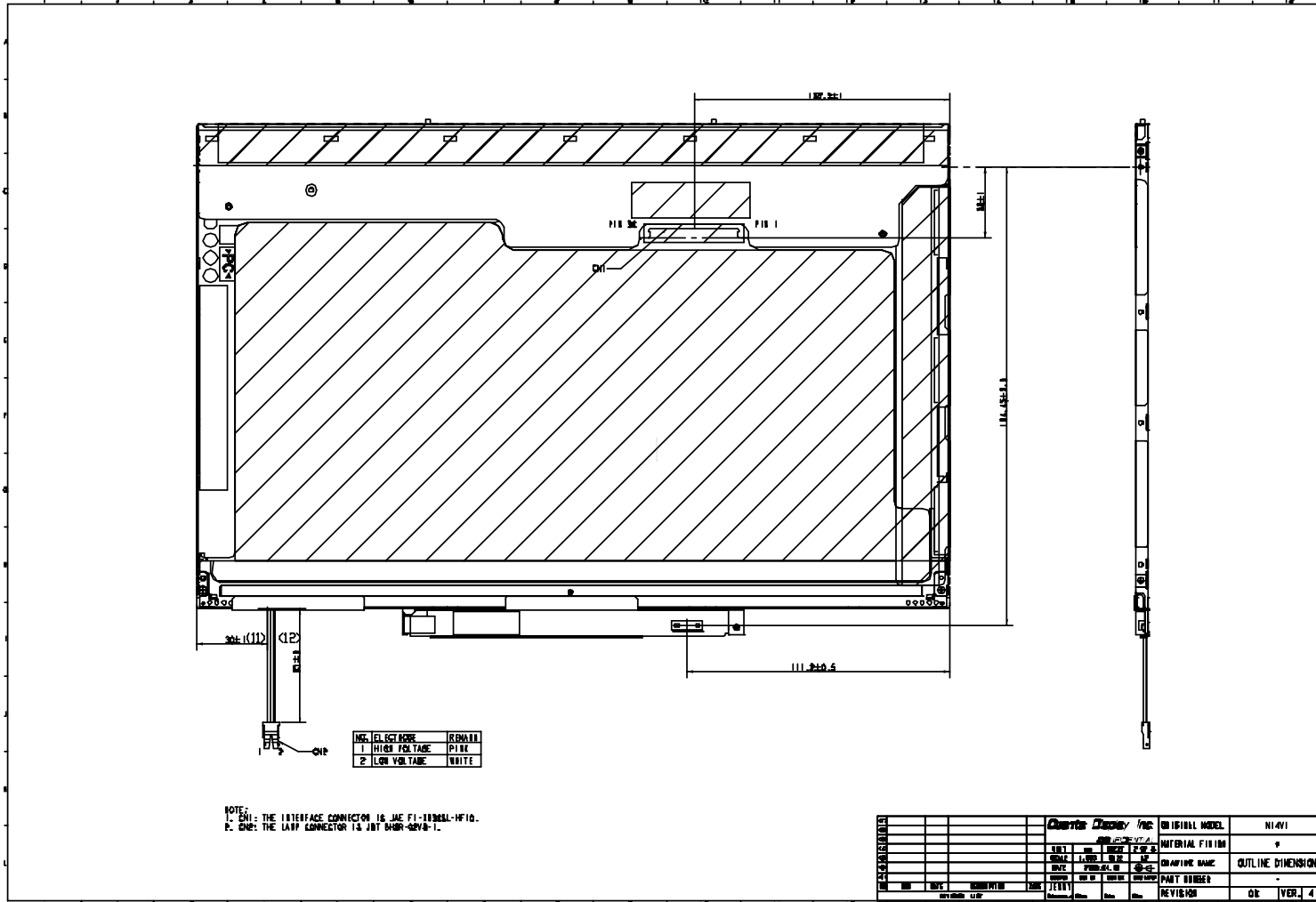

10.2 Screw Hole Depth and Center Position

Screw hole maximum depth, from side surface = 3.0 mm (See drawing)

Screw hole center location, from front surface = 3.1 ± 0.3 mm (See drawing)

Screw Torque: Maximum: 1.8 kgf-cm Minimum: 1.5 kgf-cm

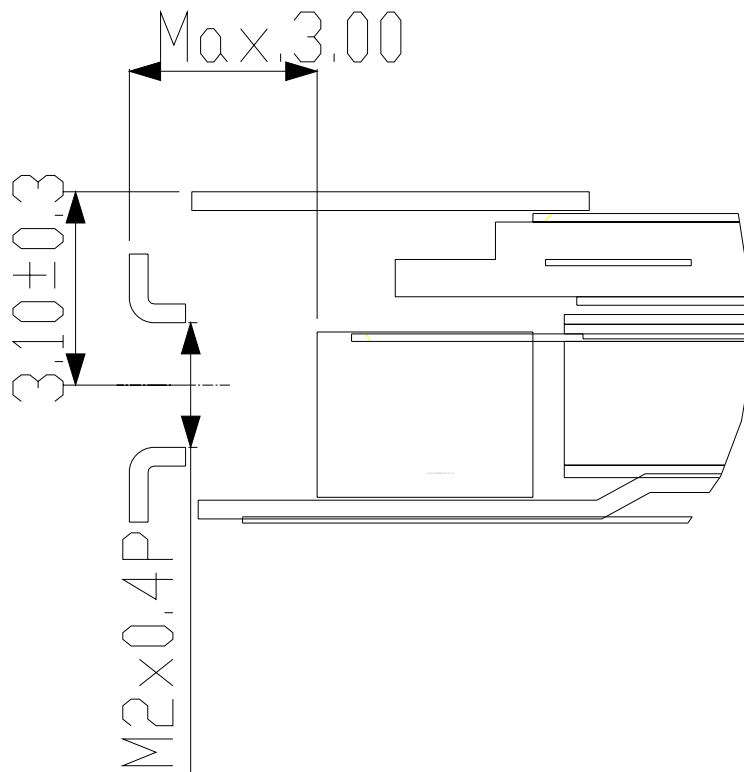



Product Specification

AU OPTRONICS CORPORATION

B141EW03 VB (QD14TL01 Rev.04)

11. Shipping and Package

11.1 Shipping Label Format



11.2 Customer Label Format.



11.2. Carton package

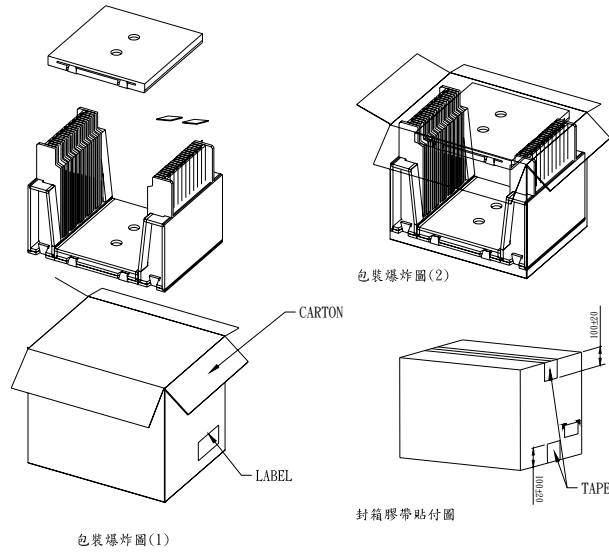

11.3 Shipping package of palletizing

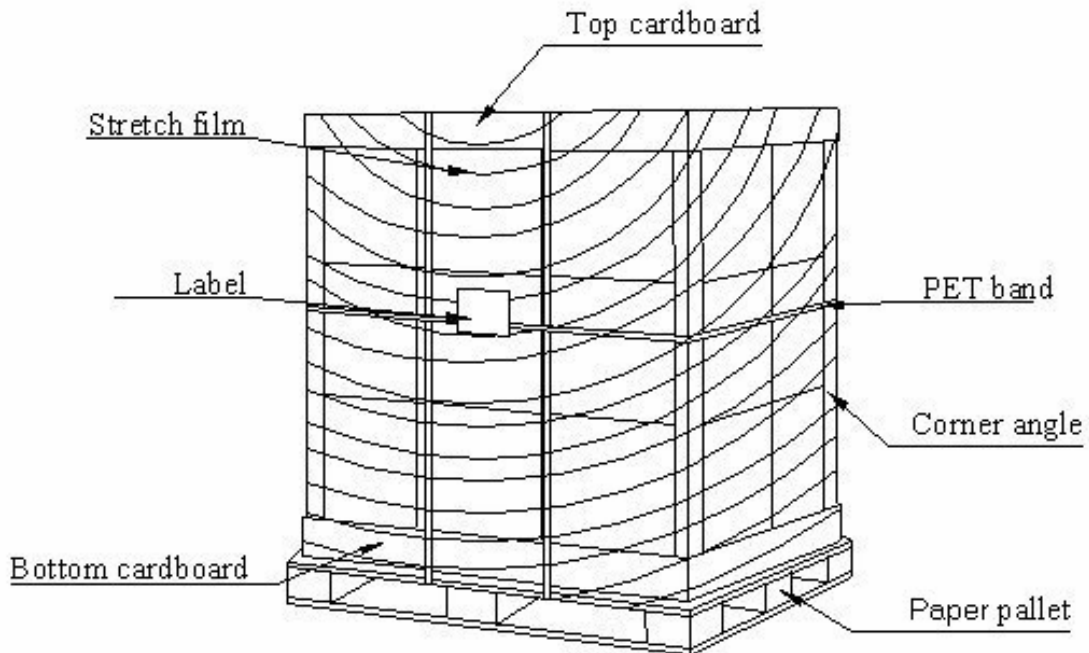



Product Specification

AU OPTRONICS CORPORATION

B141EW03 VB (QD14TL01 Rev.04)

12. Appendix: EDID description

Address (Decimal)	Byte (hex)	Field Name and Comments	Value (hex)	Value (binary)	Value (DEC)
0	0	Header	00	00000000	0
1	1	Header	FF	11111111	255
2	2	Header	FF	11111111	255
3	3	Header	FF	11111111	255
4	4	Header	FF	11111111	255
5	5	Header	FF	11111111	255
6	6	Header	FF	11111111	255
7	7	Header	00	00000000	0
8	8	EISA manufacture code = 3 Character ID	06	00000110	6
9	9	EISA manufacture code (Compressed ASCII)	AF	10101111	175
10	0A	Panel Supplier Reserved – Product Code	44	01000100	68
11	0B	Panel Supplier Reserved – Product Code	3B	00111011	59
12	0C	LCD module Serial No - Preferred but Optional (“0” if not used)	00	00000000	0
13	0D	LCD module Serial No - Preferred but Optional (“0” if not used)	00	00000000	0
14	0E	LCD module Serial No - Preferred but Optional (“0” if not used)	00	00000000	0
15	0F	LCD module Serial No - Preferred but Optional (“0” if not used)	00	00000000	0
16	10	Week of manufacture	01	00000001	1
17	11	Year of manufacture	10	00010000	16
18	12	EDID structure version # = 1	01	00000001	1
19	13	EDID revision # = 3	03	00000011	3
20	14	Video I/P definition = Digital I/P (80h)	80	10000000	128
21	15	Max H image size = (Rounded to cm)	1E	00011110	30
22	16	Max V image size = (Rounded to cm)	13	00010011	19
23	17	Display gamma = (gamma ×100)-100 = Example: (2.2×100) – 100 = 120	78	01111000	120
24	18	Feature support (no DPMS, Active off, RGB, timing BLK 1)	0A	00001010	10
25	19	Red/Green Low bit (RxRy/GxGy)	87	10000111	135



Product Specification

AU OPTRONICS CORPORATION

B141EW03 VB (QD14TL01 Rev.04)

26	1A	Blue/White Low bit (BxBY/WxWy)	F5	11110101	245
27	1B	Red X Rx = 0.xxx	94	10010100	148
28	1C	Red Y Ry = 0.xxx	57	01010111	87
29	1D	Green X Gx = 0.xxx	4F	01001111	79
30	1E	Green Y Gy = 0.xxx	8C	10001100	140
31	1F	Blue X Bx = 0.xxx	27	00100111	39
32	20	Blue Y By = 0.xxx	27	00100111	39
33	21	White X Wx = 0.xxx	50	01010000	80
34	22	White Y Wy = 0.xxx	54	01010100	84
35	23	Established timings 1 (00h if not used)	00	00000000	0
36	24	Established timings 2 (00h if not used)	00	00000000	0
37	25	Manufacturer's timings (00h if not used)	00	00000000	0
38	26	Standard timing ID1 (01h if not used)	01	00000001	1
39	27	Standard timing ID1 (01h if not used)	01	00000001	1
40	28	Standard timing ID2 (01h if not used)	01	00000001	1
41	29	Standard timing ID2 (01h if not used)	01	00000001	1
42	2A	Standard timing ID3 (01h if not used)	01	00000001	1
43	2B	Standard timing ID3 (01h if not used)	01	00000001	1
44	2C	Standard timing ID4 (01h if not used)	01	00000001	1
45	2D	Standard timing ID4 (01h if not used)	01	00000001	1
46	2E	Standard timing ID5 (01h if not used)	01	00000001	1
47	2F	Standard timing ID5 (01h if not used)	01	00000001	1
48	30	Standard timing ID6 (01h if not used)	01	00000001	1
49	31	Standard timing ID6 (01h if not used)	01	00000001	1
50	32	Standard timing ID7 (01h if not used)	01	00000001	1
51	33	Standard timing ID7 (01h if not used)	01	00000001	1
52	34	Standard timing ID8 (01h if not used)	01	00000001	1
53	35	Standard timing ID8 (01h if not used)	01	00000001	1
54	36	Pixel Clock/10,000 (LSB)	C7	11000111	199
55	37	Pixel Clock/10,000 (MSB)	1B	00011011	27
56	38	Horizontal Active = 1280 pixels (lower 8 bits)	00	00000000	0
57	39	Horizontal Blanking (Thbp) = 160 pixels (lower	A0	10100000	160



Product Specification

AU OPTRONICS CORPORATION

B141EW03 VB (QD14TL01 Rev.04)

		8 bits)			
58	3A	Horizontal Active/Horizontal blanking (Thbp) (upper4:4 bits)	50	01010000	80
59	3B	Vertical Active = 800 lines	20	00100000	32
60	3C	Vertical Blanking (Tvbp) = 23 lines (DE Blanking typ. for DE only panels)	17	00010111	23
61	3D	Vertical Active : Vertical Blanking (Tvbp) (upper4:4 bits)	30	00110000	48
62	3E	Horizontal Sync, Offset (Thfp) = 48 pixels	30	00110000	48
63	3F	Horizontal Sync, Pulse Width = 32 pixels	20	00100000	32
64	40	Vertical Sync, Offset (Tvfp) = 3 lines Sync Width = 6 lines	36	00110110	54
65	41	Horizontal Vertical Sync Offset/Width upper 2 bits	00	00000000	0
66	42	Horizontal Image Size =304 mm	30	00110000	48
67	43	Vertical image Size = 190 mm	BE	10111110	190
68	44	Horizontal Image Size / Vertical image size	10	00010000	16
69	45	Horizontal Border = 0 (Zero for Notebook LCD)	00	00000000	0
70	46	Vertical Border = 0 (Zero for Notebook LCD)	00	00000000	0
71	47	Non-interlaced, Normal, no stereo, Separate sync, H/V pol Negatives, DE only note: LSB is set to "1" if panel is DE-timing only. H/V can be ignored.	19	00011001	25
72	48	Pixel Clock/10,000 (LSB)	26	00100110	38
73	49	Pixel Clock/10,000 (MSB)	17	00010111	23
74	4A	Horizontal Active = xxxx pixels (lower 8 bits)	00	00000000	0
75	4B	Horizontal Blanking (Thbp) = xxxx pixels (lower 8 bits)	A0	10100000	160
76	4C	Horizontal Active/Horizontal blanking (Thbp) (upper4:4 bits)	50	01010000	80
77	4D	Vertical Active = xxxx lines	20	00100000	32
78	4E	Vertical Blanking (Tvbp) = xxxx lines (DE Blanking typ. for DE only panels)	17	00010111	23
79	4F	Vertical Active : Vertical Blanking (Tvbp) (upper4:4 bits)	30	00110000	48



Product Specification

AU OPTRONICS CORPORATION

B141EW03 VB (QD14TL01 Rev.04)

80	50	Horizontal Sync, Offset (Thfp) = xxxx pixels	30	00110000	48
81	51	Horizontal Sync, Pulse Width = xxxx pixels	20	00100000	32
82	52	Vertical Sync, Offset (Tvfp) = xx lines Sync Width = xx lines	36	00110110	54
83	53	Horizontal Vertical Sync Offset/Width upper 2 bits	00	00000000	0
84	54	Horizontal Image Size =xxx mm	30	00110000	48
85	55	Vertical image Size = xxx mm	BE	10111110	190
86	56	Horizontal Image Size / Vertical image size	10	00010000	16
87	57	Horizontal Border = 0 (Zero for Notebook LCD)	00	00000000	0
88	58	Vertical Border = 0 (Zero for Notebook LCD)	00	00000000	0
89	59	Module "A" Revision = Example: 00, 01, 02, 03, etc.	00	00000000	0
90	5A	Flag	00	00000000	0
91	5B	Flag	00	00000000	0
92	5C	Flag	00	00000000	0
93	5D	Dummy Descriptor	FE	11111110	254
94	5E	Flag	00	00000000	0
95	5F	Dell P/N 1 st Character (G)	47	01000111	71
96	60	Dell P/N 2 nd Character (M)	4D	01001101	77
97	61	Dell P/N 3 rd Character (5)	35	00110101	53
98	62	Dell P/N 4 th Character (2)	32	00110010	50
99	63	Dell P/N 5 th Character (1)	31	00110001	49
100	64	LCD Supplier EEDID Revision #	00	00000000	0
101	65	Manufacturer P/N	42	01000010	66
102	66	Manufacturer P/N	31	00110001	49
103	67	Manufacturer P/N	34	00110100	52
104	68	Manufacturer P/N	31	00110001	49
105	69	Manufacturer P/N	45	01000101	69
106	6A	Manufacturer P/N	57	01010111	87
107	6B	Manufacturer P/N (If <13 char, then terminate with ASCII code 0Ah, set remaining char = 20h)	33	00110011	51
108	6C	Flag	00	00000000	0
109	6D	Flag	00	00000000	0
110	6E	Flag	00	00000000	0
111	6F	Data Type Tag:	FE	11111110	254



Product Specification

AU OPTRONICS CORPORATION

B141EW03 VB (QD14TL01 Rev.04)

112	70	Flag	00	00000000	0
113	71	SMBUS Value = XX nits	27	00100111	39
114	72	SMBUS Value = XX nits	35	00110101	53
115	73	SMBUS Value = XX nits	41	01000001	65
116	74	SMBUS Value = XX nits	48	01001000	72
117	75	SMBUS Value = XX nits	66	01100110	102
118	76	SMBUS Value = XXX nits	85	10000101	133
119	77	SMBUS Value = XXX nits	AB	10101011	171
120	78	SMBUS Value = max nits (Typically = 00h, XXX nits)	FF	11111111	255
121	79	Number of LVDS receiver chips = '01' or '02'	01	00000001	1
122	7A	BIST Enable: Yes = '01' No = '00'	01	00000001	1
123	7B	(If <13 char, then terminate with ASCII code 0Ah, set remaining char = 20h)	0A	00001010	10
124	7C	(If <13 char, then terminate with ASCII code 0Ah, set remaining char = 20h)	20	00100000	32
125	7D	(If <13 char, then terminate with ASCII code 0Ah, set remaining char = 20h)	20	00100000	32
126	7E	Extension flag (# of optional 128 EDID extension blocks to follow, Typ = 0)	00	00000000	0
127	7F	Checksum (The 1-byte sum of all 128 bytes in this EDID block shall = 0)	C3	11000011	195