



Date: 2005/11/28

Product Functional Specification

14.1 inch XGA Color TFT LCD Module

Model name : B141XG09 V4

Toshiba model name : G33C00038110

() Preliminary Specification

(u) Final Specification

NOTICE of RECEIPT

We accepted this specification. **OME Operations, TOSHIBA Corp.**

Purchasing dept.	Eng.	Senr. Eng.	Senr. Mgr.
PC Hardware dept.	Eng.	Senr. Eng.	Senr. Mgr.

Note: This Specification is subject to change without notice.

Contents

1.0 Handling Precautions	4
2.0 General Description.....	5
2.1 Display Characteristics.....	5
2.2 Functional Block Diagram	6
3.0 Absolute Maximum Ratings	7
3.1 Mechanical Ratings.....	8
4.0 Optical Characteristics.....	12
5.0 Signal Interface.....	17
5.1 Connectors.....	17
5.2 Signal Pin.....	17
5.3 Signal Description	18
5.4 Signal Electrical Characteristics	19
5.5 Signal for Lamp connector	19
6.0 Pixel Format Image.....	20
7.0 Parameter guide line for CCFL Inverter	20
8.0 Interface Timings.....	21
8.1 Timing Characteristics.....	21
8.2 Timing Definition	22
9.0 Power Consumption	23
10. Power ON/OFF Sequence	24
11.0 Reliability /Safety Requirement.....	25
11.1 Reliability Test Conditions.....	25
11.2 Safety.....	25
11.3 Others	25
12.0 Packing Dimension.....	26
12.1 Packing method	26
12.2 Packing Specification.....	27
12.3 Package Label	27
12.4 Location of Package Label	27
12.5 Panel Code Label on LCD	27
12.6 Location of Panel Label	28
13.0 Mechanical Characteristics.....	29
13.1 LCM Outline dimension (Front View).....	29
13.2 LCM Outline Dimension (Rear View).....	30
13.3 Screw Hole Depth and Center Position.....	31
14.0 EDID.....	32

II Record of Revision

Version and Date	Page	Old description	New Description	Remark
V1. 2005/11/23	All	First Release	NA	
V2. 2005/12/28	12	Brightness 160nit (min)	Brightness 175nit (min)	
	12		Add CR Value: 350 (typ)	
	12	Cross Talk: 4.0% (max)	Cross Talk: 2.0% (max)	
	12		Add CR Variation (13 points): 1.6 (max)	

1.0 Handling Precautions

- 1) Do not press or scratch the surface harder than a HB pencil lead because the polarizers are very fragile and could be easily damaged.
- 2) Be sure to turn off power supply when inserting or disconnecting from input connector.
- 3) Wipe off water droplets or oil immediately. Long contact with the droplets may cause discoloration or spots.
- 4) When the panel surface is soiled, wipe it with absorbent cotton or other soft cloth.
- 5) Since the panel is made of glass, it may break or crack if dropped or bumped on hard surface.
- 6) Protect the module from static electricity and insure proper grounding when handling. Static electricity may cause damage to the CMOS Gate Array IC.
- 7) Do not disassemble the module.
- 8) Do not press the reflector sheet at the back of the module.
- 9) Avoid damaging the TFT module. Do not press the center of the CCFL Reflector when it was taken out from the packing container. Instead, press at the edge of the CCFL Reflector softly.
- 10) Do not rotate or tilt the signal interface connector of the TFT module when you insert or remove other connector into the signal interface connector.
- 11) Do not twist or bend the TFT module when installation of the TFT module into an enclosure (Notebook PC Bezel, for example). It should be taken into consideration that no bending/twisting forces are applied to the TFT module from outside when designing the enclosure. Otherwise the TFT module may be damaged.
- 12) Cold cathode fluorescent lamp in LCD contains a small amount of mercury. Please follow local regulations for disposal.
- 13) The LCD module contains a small amount of material that has no flammability grade, so it should be supplied by power complied with requirements of limited power source (2.11, IEC60950 or UL1950).
- 14) The CCFL in the LCD module is supplied with Limited Current Circuit (2.4, IEC60950 or UL1950). Do not connect the CCFL in Hazardous Voltage Circuit.

2.0 General Description

This specification applies to the 14.1 inch Color TFT/LCD Module B141XG09 V4

This module is designed for a display unit of notebook style personal computer.

The screen format is intended to support the XGA (1024(H) x 768(V)) screen and 262k colors (RGB 6-bits data driver).

All input signals are LVDS interface compatible.

This module does not contain an inverter card for backlight.

2.1 Display Characteristics

The following items are characteristics summary on the table under 25 °C condition:

ITEMS	Unit	SPECIFICATIONS
Screen Diagonal	[mm]	357(14.1")
Active Area	[mm]	285.7(H) x 214.3(V)
Pixels H x V		1024(x3) x 768
Pixel Pitch	[mm]	0.279(per one triad) x 0.279
Pixel Arrangement		R.G.B. Vertical Stripe
Display Mode		Normally White
Typical White Luminance(CCFL=6.0mA)	[cd/m ²]	200 Typ.(5 points average)
Contrast Ratio		300:1 Min.
Response Time	[msec]	25 Typ.
Nominal Input Voltage VDD	[Volt]	+3.3 Typ.
Typical Power Consumption (VDD line + VCFL line)	[Watt]	5.3 Watt (w/o Inverter, All black pattern)@LCM circuit 1.4 Watt(typ.),B/L input 3.9 Watt(typ.)
Weight	[Grams]	420g Max.
Physical Size	[mm]	299(W) x 228(H) x 5.5(D) Max.
Electrical Interface		R/G/B Data, 3 Sync, Signals, Clock (4 pairs LVDS)
Surface Treatment		Anti-glare, Haze 25, Hardness 3H
Support Color		Native 262K colors (RGB 6-bit data driver)
Temperature Range Operating Storage (Shipping)	[°C] [°C]	0 to +50 -20 to +60

2.2 Functional Block Diagram

The following diagram shows the functional block of the 14.1 inches Color TFT/LCD Module:

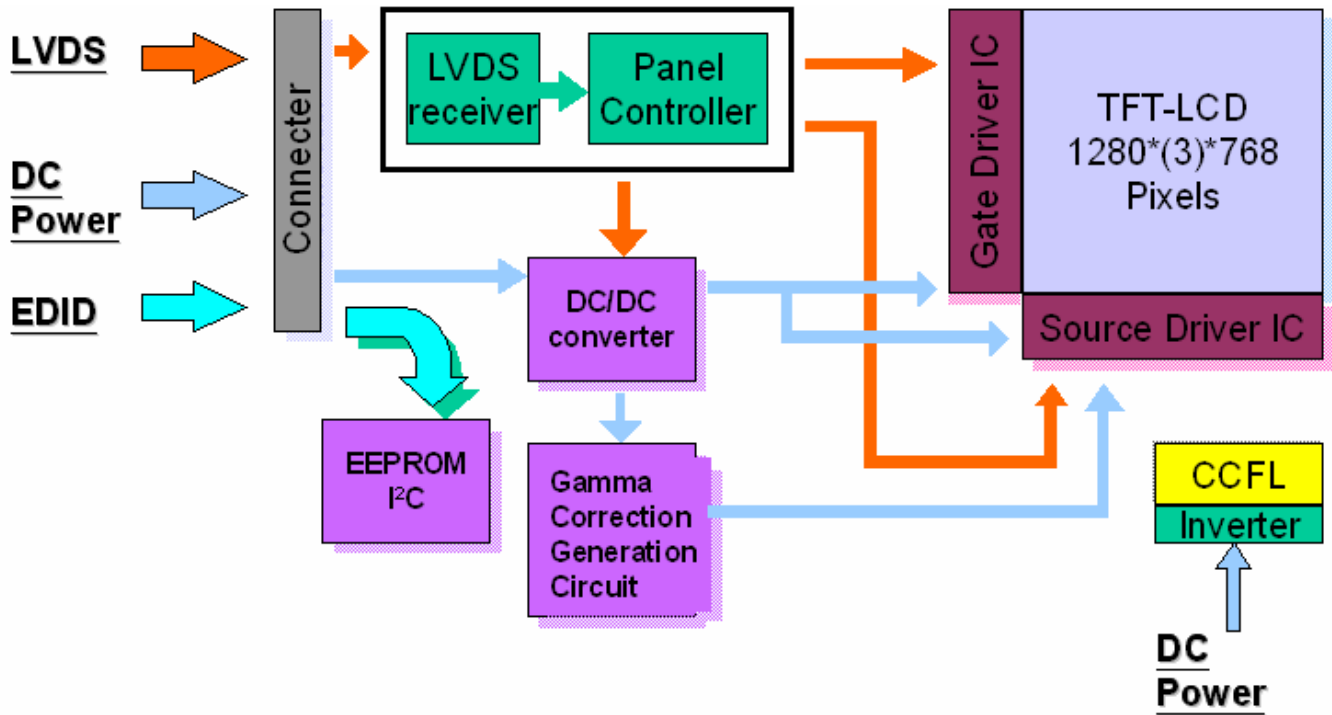

3.0 Absolute Maximum Ratings

Absolute maximum ratings of the module are as following:

Item	Symbol	Min	Max	Unit	Conditions
Logic/LCD Drive Voltage	VDD	-0.3	+4.0	[Volt]	
Input Voltage of Signal	Vin	-0.3	VDD+0.3	[Volt]	
CCFL Current	ICFL	-	6.5	[mA] rms	
CCFL Ignition Voltage	Vs	-	1160(25°C)	Vrms	Note 1
Operating Temperature	TOP	0	+50	[°C]	Note 2
Operating Humidity	HOP	5	95	[%RH]	Note 2
Storage Temperature	TST	-20	+60	[°C]	Note 2
Storage Humidity	HST	5	95	[%RH]	Note 2
Vibration			1.5 ,10-500	[G Hz]	
Shock			240 , 2	[G ms]	Half sine wave

Note 1 : Duration = 50msec

Note 2 : Maximum Wet-Bulb should be 39°C and No condensation.

Wet bulb temperature chart

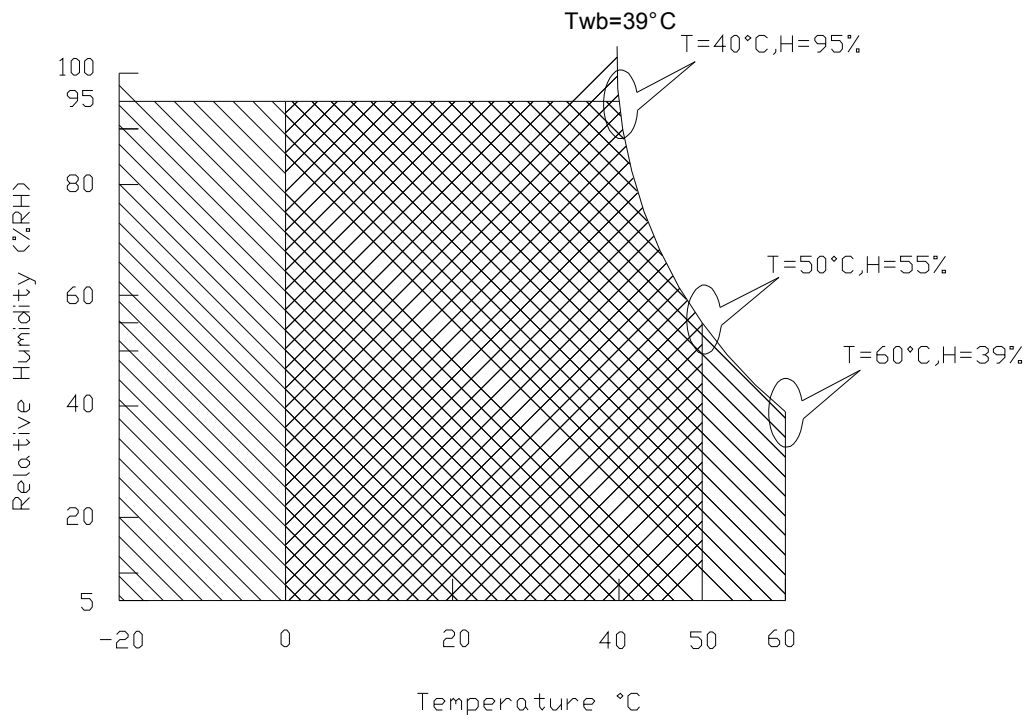

Operating Range  Storage Range  + 

(C) Copyright AU Optronics

Dec., 2002 All Rights Reserved.

B141XG09 V4

No Reproduction and Redistribution Allowed.

3.1 Mechanical Ratings

LCD shall have no failure in the following reliability tests.

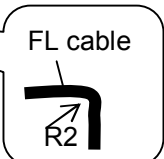
Test Item	Test Conditions		Note
Mechanical Vibration	Frequency Range 10 - 500 Hz, 14.7m/s ² (1.5G) constant, 0.5Hrs each axis (X, Y, Z direction)		Non Operation
Strength of FL Cable	Strength of rotation force	Cable : No disconnection of cable to the 5 trial of 360 degree rotation. See a bended state of cable.	Non Operation 
		Connector : No disconnection of cable to 10 trial of 180 degree rotation. See a bended state of cable.	
	Lead pull test	Soldering portion : 29.4N (3.0 kgf), 10 minutes Connector : 14.7N (1.5kgf), 1 second	
Connector tension test	Input connector : With 50 times of connector trial there must be no damage to the shape and functionality.		Non Operation
	Back light connector : With 50 times of connector trial there must be no damage to the shape and functionality.		
Assured torque value at side-mount screw hole	M2 : Max 2.5 kgf-cm		Non Operation
Mechanical Shock	240G, Pulse width 2 ms, Half-sine Wave, ±X, ±Y, ±Z direction		Non Operation
Mechanical Shock	240G, Pulse width 2 ms, Sine Wave, ±X, ±Y, ±Z direction		Non Operation
LCD fix condition -> See Note (2)			

Note (1) Pushing points of Pressure Resistance

(1) The compression condition of front side

(a) Compression point : 12 points (refer to Fig 1-1)

(b) Compression condition: 20kgf, 3 sec, Tool diameter: 16 mm in diameter (refer to Fig 1-3)

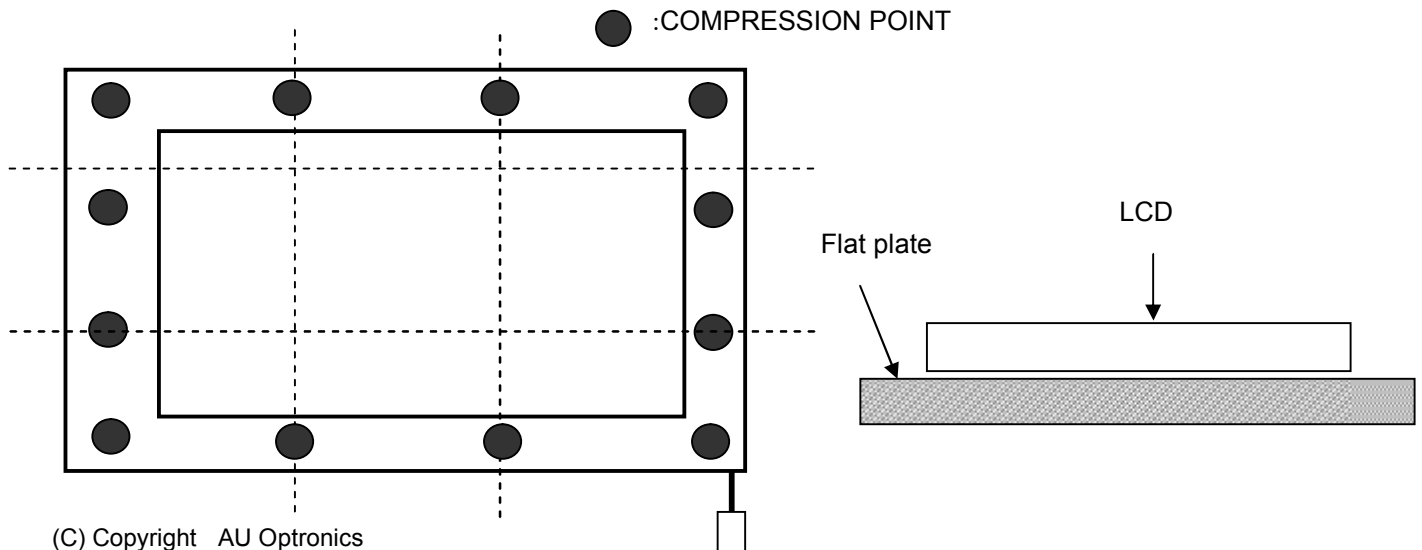

(C) Copyright AU Optronics

Dec., 2002 All Rights Reserved.

B141XG09 V4

No Reproduction and Redistribution Allowed.

Note (2) LCD fixing condition for z direction

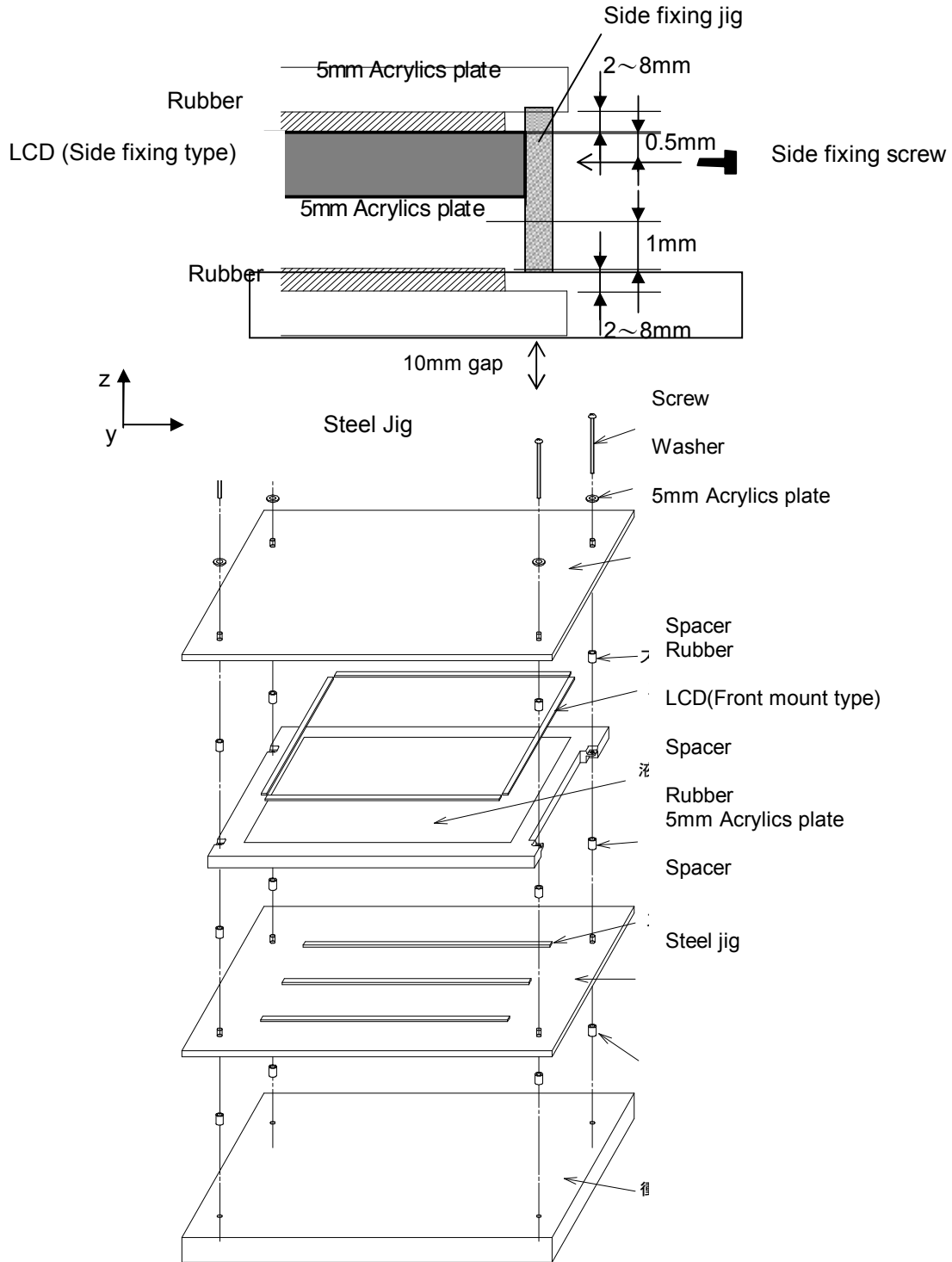

Note (3) Spec points of strength of FL cable

Strength of rotation force

1) 360deg rotation / 5 times

2) 180deg rotation / 10 times

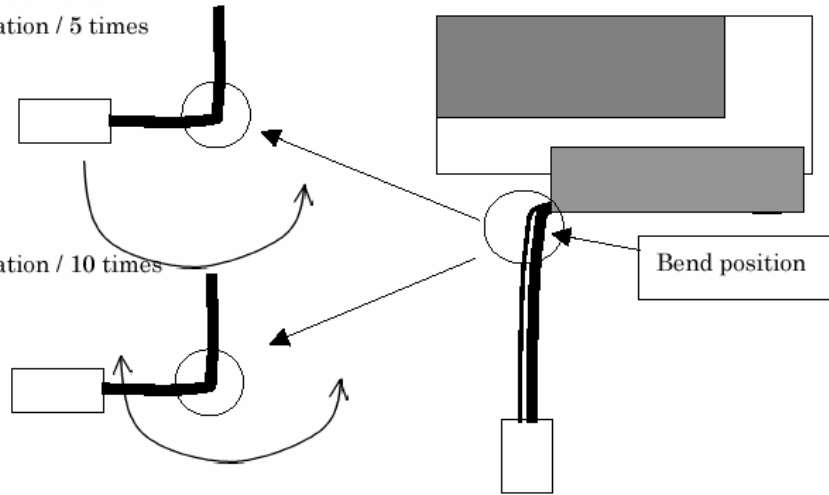

Strength of pull force

3) Soldering portion (Joint portion between lamp terminal and cable)

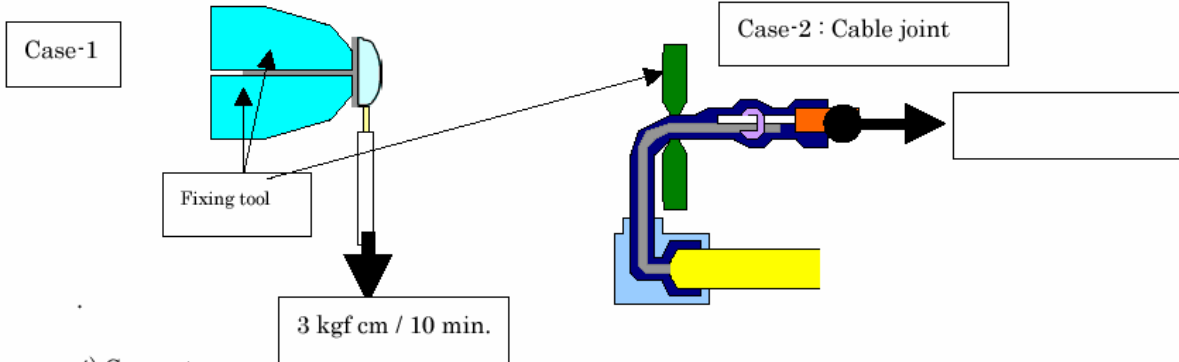

4) Connector

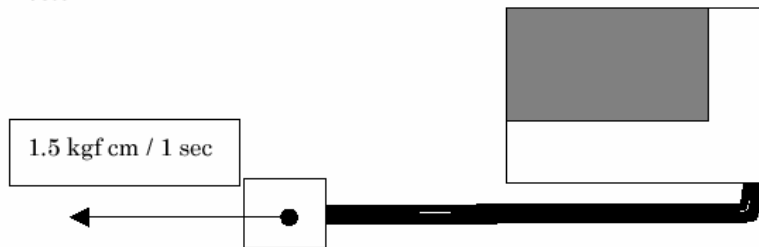

4.0 Optical Characteristics

The optical characteristics are measured under stable conditions as follows under 25°C condition:

Item	Unit	Conditions	Min.	Typ.	Max.	Note
Viewing Angle	[degree] [degree]	Horizontal (Right) CR = 10 (Left)	40 40	- -	- -	3,7
CR: Contrast Ratio	[degree] [degree]	Vertical (Upper) CR = 10 (Lower)	10 30	- -	- -	
Uniformity		5 Points			1.2	2
Uniformity		13 Points			1.5	
Contrast ratio			300	350	-	6
Response Time	[msec]	Rising	-	10	15	5
	[msec]	Falling	-	15	20	
Color / Chromaticity Coordinates (CIE 1931)		Red x	0.550	0.580	0.610	3,7
		Red y	0.310	0.340	0.370	
		Green x	0.280	0.310	0.340	
		Green y	0.520	0.550	0.580	
		Blue x	0.120	0.150	0.180	
		Blue y	0.100	0.130	0.160	
		White x	0.283	0.313	0.343	
		White y	0.299	0.329	0.359	
White Luminance CCFL 6.0mA	[cd/m ²]	5 points average	175	200	-	1,3,4
Cross talk	%	$\theta = 0^\circ, \Phi = 0^\circ$ Viewing Normal Angle			2.0	3,8
CR Variation		13 points			1.6	1,2,3,6

Note 1: 5 & 13 points position (Display area: 285.7mm x 214.3mm)

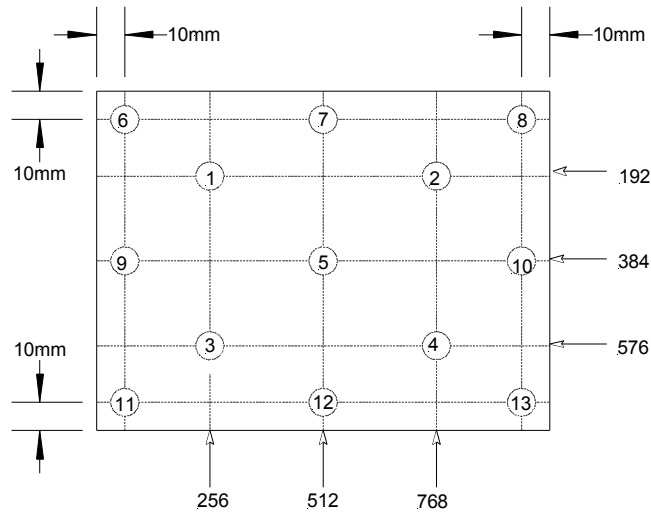

Note 2: Definition of white uniformity:

White uniformity is defined as the following with five/thirteen measurements (1~13) at Figure in Note (1).

$$\delta_{w5} = \frac{\text{Maximum Brightness of five (1,2,3,4,5) points}}{\text{Minimum Brightness of five (1,2,3,4,5) points}}$$

$$\delta_{w13} = \frac{\text{Maximum Brightness of thirteen points}}{\text{Minimum Brightness of thirteen points}}$$

$$\delta_{CR13} = \frac{\text{Maximum CR of thirteen points}}{\text{Minimum CR of thirteen points}}$$

Note 3: Measurement method

(C) Copyright AU Optronics

Dec., 2002 All Rights Reserved.

B141XG09 V4

No Reproduction and Redistribution Allowed.

The LCD module should be stabilized at given temperature for 30 minutes to avoid abrupt temperature change during measuring. In order to stabilize the luminance, the measurement should be executed after lighting Backlight for 30 minutes in a stable, windless and dark room.

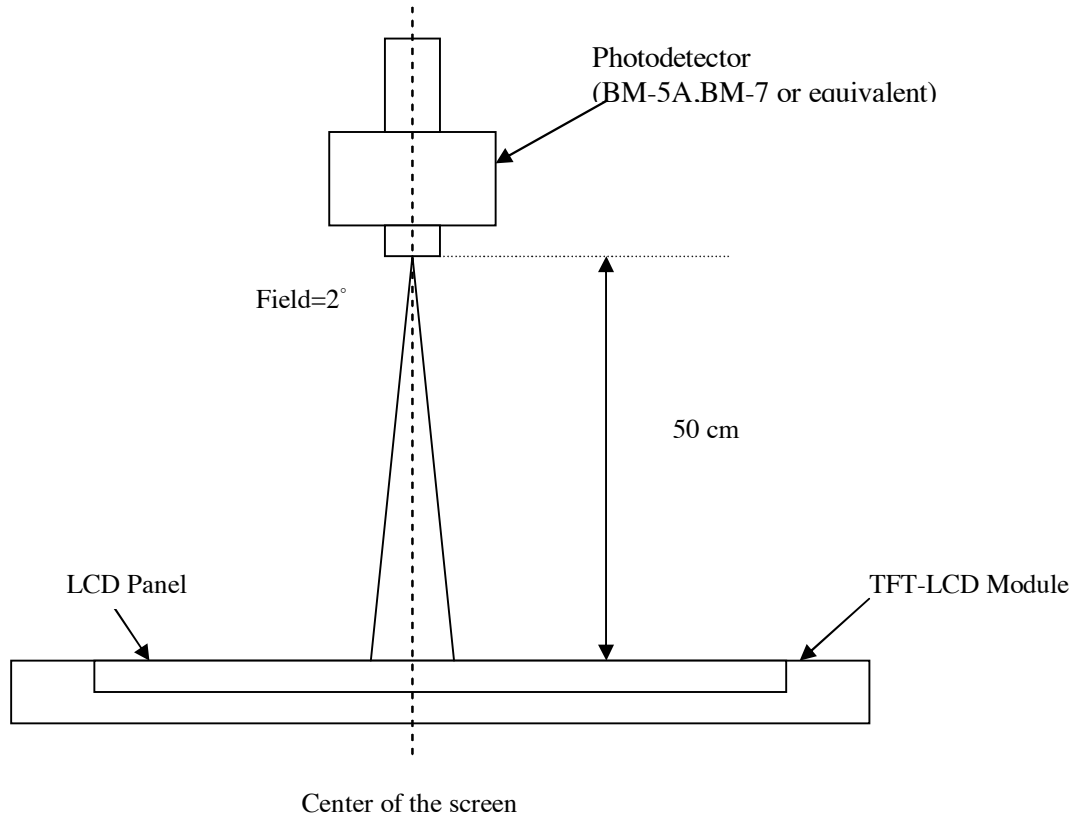

Note 4: Definition of Average Luminance of White (Y_L):

Measure the luminance of gray level 63 at 5 points, $Y_L = [L(1) + L(2) + L(3) + L(4) + L(5)] / 5$

$L(x)$ is corresponding to the luminance of the point X at Figure in Note (1).

Note 5: Definition of response time:

The output signals of BM-7 or equivalent are measured when the input signals are changed from “Black” to “White” (falling time) and from “White” to “Black” (rising time), respectively. The response time interval between the 10% and 90% of amplitudes. Refer to figure as below.

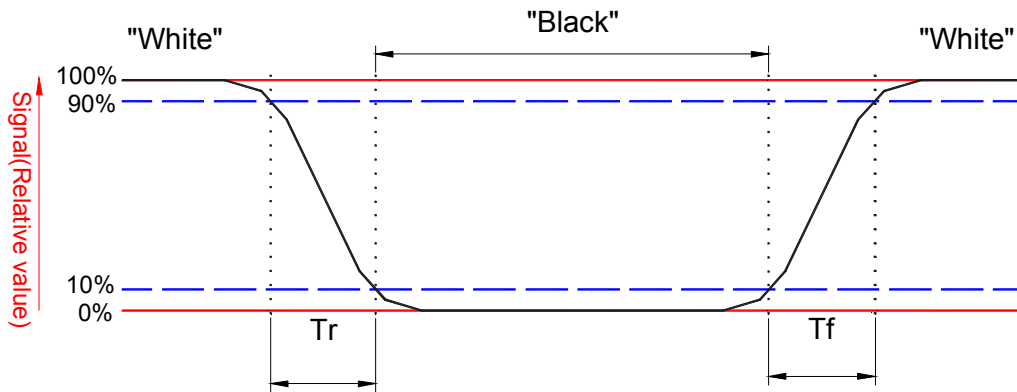

Note 6. Definition of contrast ratio:

Contrast ratio is calculated with the following formula.

$$\text{Contrast ratio (CR)} = \frac{\text{Brightness on the "White" state}}{\text{Brightness on the "Black" state}}$$

Note 7. Definition of viewing angle

Viewing angle is the measurement of contrast ratio ≥ 10 , at the screen center, over a 180° horizontal and 180° vertical range (off-normal viewing angles). The 180° viewing angle range is broken down as follows; 90° (θ) horizontal left and right and 90° (Φ) vertical, high (up) and low (down). The measurement direction is typically perpendicular to the display surface with the screen rotated about its center to develop the desired measurement viewing angle.

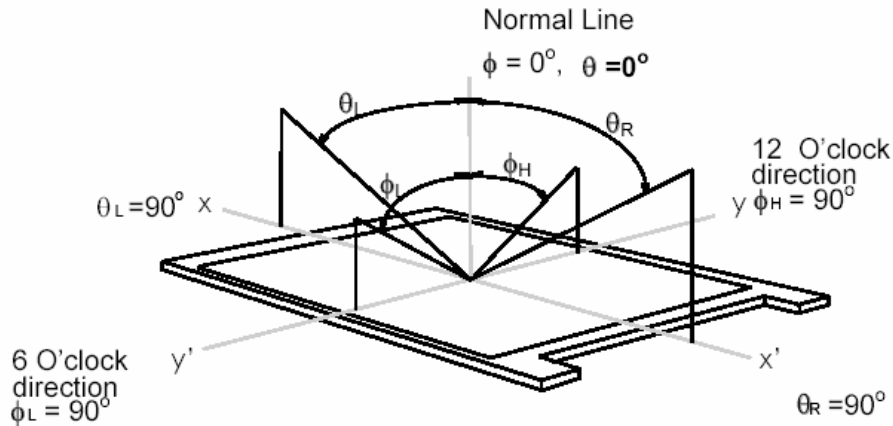

Note 8. Definition of Cross Talk:

$$\text{Cross Talk} = |Y_B - Y_A| / Y_A \times 100 (\%)$$

Where:

Y_A = Luminance of measured location without gray level 0 pattern (cd/m^2)

Y_B = Luminance of measured location with gray level 0 pattern (cd/m^2)

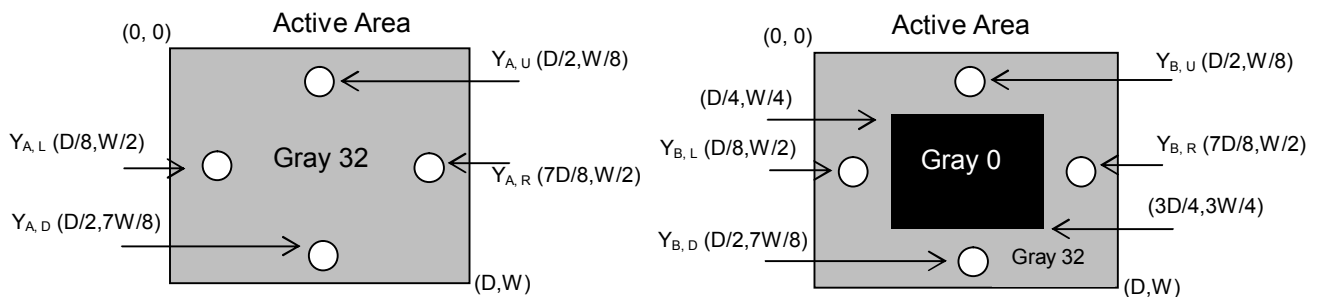

5.0 Signal Interface

5.1 Connectors

Physical interface is described as for the connector on module.

These connectors are capable of accommodating the following signals and will be following components.

Connector Name / Designation	For Signal Connector
Manufacturer	JAE
Type / Part Number	FI-XB30S-HF10
Mating Housing/Part Number	FI-X30H
Mating Contact/Part Number	FI-XC3-1-15000

Connector Name / Designation	For Lamp Connector
Manufacturer	JST
Type / Part Number	BHTR-02VS
Mating Type / Part Number	BHTMR-02V

5.2 Signal Pin

Pin#	Signal Name	Pin#	Signal Name
1	GND	2	VDD
3	VDD	4	V _{EDID}
5	NC	6	CLK _{EDID}
7	DATA _{EDID}	8	RxIN0-
9	RxIN0+	10	GND
11	RxIN1-	12	RxIN1+
13	GND	14	RxIN2-
15	RxIN2+	16	GND
17	RxCLKIN-	18	RxCLKIN+
19	GND	20~30	NC

5.3 Signal Description

The module uses a LVDS receiver embedded in AUOs ASIC. LVDS is a differential signal technology for LCD interface and high-speed data transfer device.

Signal Name	Description
V _{EDID}	+3.3V EDID Power
CLK _{EDID}	EDID Clock Input
DATA _{EDID}	EDID Data Input
RxIN0-, RxIN0+	LVDS differential data input(Red0-Red5, Green0)
RxIN1-, RxIN1+	LVDS differential data input(Green1-Green5, Blue0-Blue1)
RxIN2-, RxIN2+	LVDS differential data input(Blue2-Blue5, Hsync, Vsync, DSPTMG)
RxCLKIN-, RxCLKIN0+	LVDS differential clock input
VDD	+3.3V Power Supply
GND	Ground

Note: Input signals shall be in low status when VDD is off.

Internal circuit of LVDS inputs are as following.

Signal Name	Description	
+RED5 +RED4 +RED3 +RED2 +RED1 +RED0	Red Data 5 (MSB) Red Data 4 Red Data 3 Red Data 2 Red Data 1 Red Data 0 (LSB) Red-pixel Data	Red-pixel Data Each red pixel's brightness data consists of these 6 bits pixel data.
+GREEN 5 +GREEN 4 +GREEN 3 +GREEN 2 +GREEN 1 +GREEN 0	Green Data 5 (MSB) Green Data 4 Green Data 3 Green Data 2 Green Data 1 Green Data 0 (LSB) Green-pixel Data	Green-pixel Data Each green pixel's brightness data consists of these 6 bits pixel data.
+BLUE 5 +BLUE 4 +BLUE 3 +BLUE 2 +BLUE 1 +BLUE 0	Blue Data 5 (MSB) Blue Data 4 Blue Data 3 Blue Data 2 Blue Data 1 Blue Data 0 (LSB) Blue-pixel Data	Blue-pixel Data Each blue pixel's brightness data consists of these 6 bits pixel data.
-DTCLK	Data Clock	The typical frequency is 65.0 MHz. The signal is used to strobe the pixel data and DSPTMG signals. All pixel data shall be valid at the falling edge when the DSPTMG signal is high.
DSPTMG	Display Timing	This signal is strobed at the falling edge of -DTCLK. When the signal is high, the pixel data shall be valid to be displayed.
VSYNC	Vertical Sync	The signal is synchronized to -DTCLK .
HSYNC	Horizontal Sync	The signal is synchronized to -DTCLK .

Note: Output signals from any system shall be low or Hi-Z state when VDD is off.

5.4 Signal Electrical Characteristics

Input signals shall be in low status when VDD is off.

It is recommended to refer the specifications of SN75LVDS86DGG (Texas Instruments) in detail.

Signal electrical characteristics are as follows;

Parameter	Condition	Min	Max	Unit
Vth	Differential Input High Voltage(Vcm=+1.2V)		100	[mV]
Vtl	Differential Input Low Voltage(Vcm=+1.2V)	-100		[mV]

LVDS Macro AC characteristics are as follows:

	Min.	Max.
Clock Frequency (F)	50MHz	67MHz
Data Setup Time (Tsu)	600ps	
Data Hold Time (Thd)	600ps	

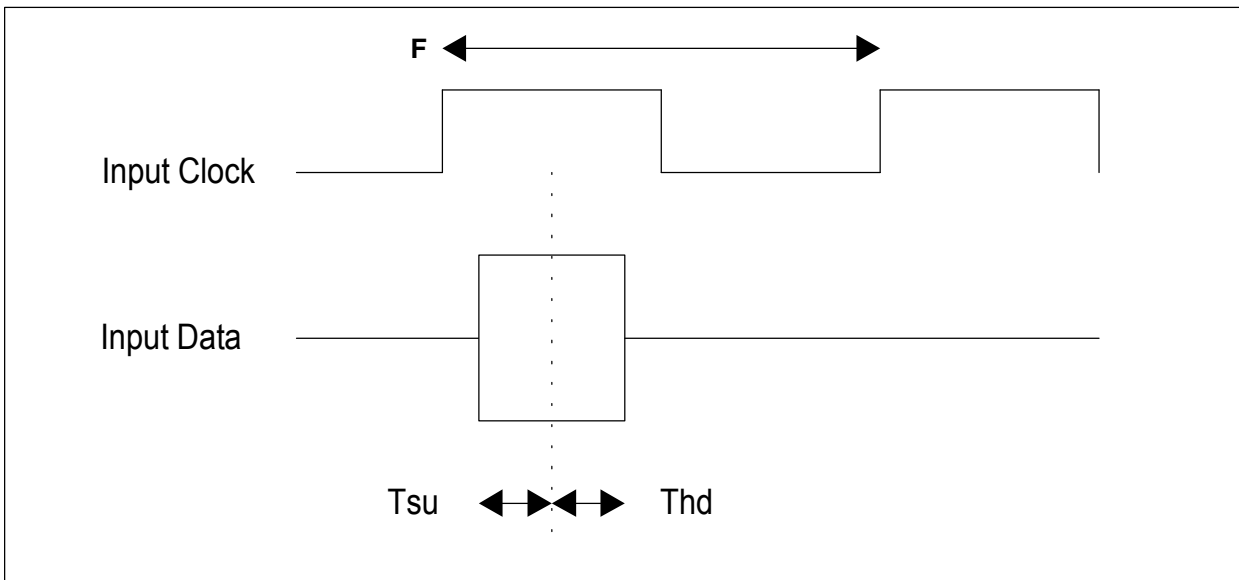

5.5 Signal for Lamp connector

Pin #	Signal Name
1	Lamp High Voltage
2	Lamp Low Voltage

6.0 Pixel Format Image

Following figure shows the relationship of the input signals and LCD pixel format.

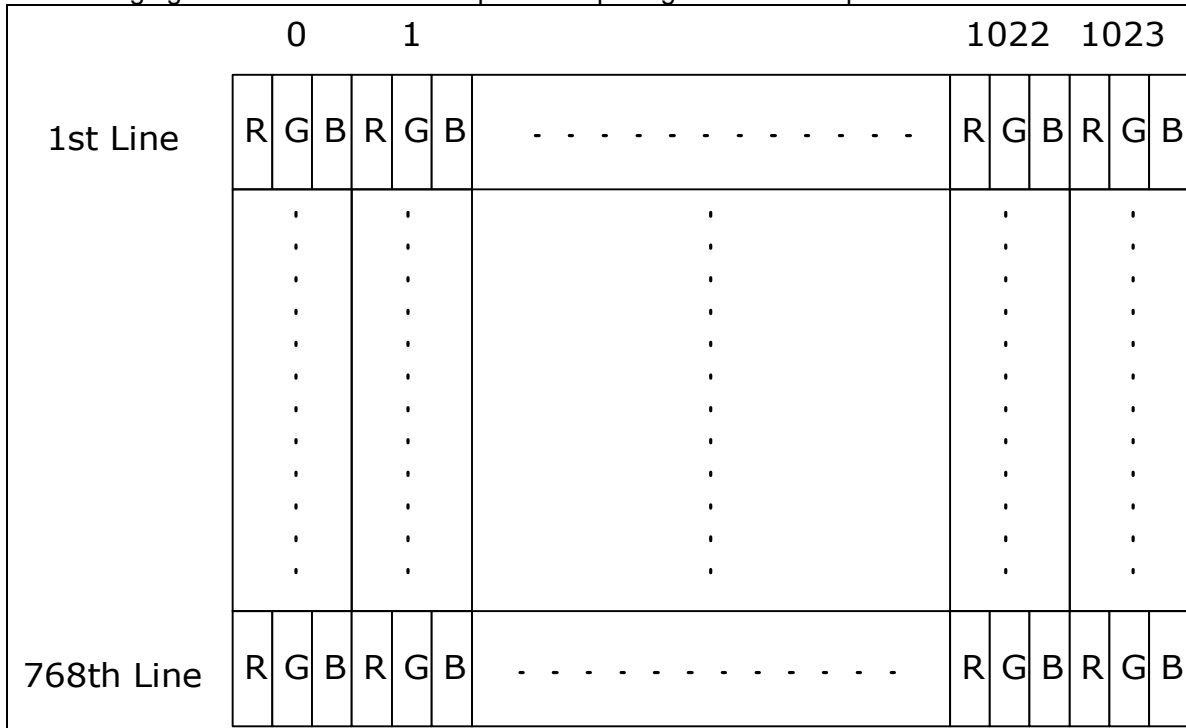

7.0 Parameter guide line for CCFL Inverter

Parameter	Min	DP-1	Max	Units	Condition
White Luminance 5 points average	160	200	—	[cd/m ²]	(Ta=25°C)
CCFL current(ICFL)	3.0	6.0	6.5	[mA] rms	(Ta=25°C) Note 2
CCFL Frequency(FCFL)	50	60	70	[KHz]	(Ta=25°C) Note 3
CCFL Ignition Voltage(Vs)	1500	—	—	[Volt] rms	(Ta= 0°C) Note 4
CCFL Voltage (Reference) (VCFL)	—	650	—	[Volt] rms	(Ta=25°C) Note 5
CCFL Power consumption (PCFL)	—	3.9	—	[Watt]	(Ta=25°C) Note 5

Note 1: DP-1 are AUO recommended Design Points.

*1 All of characteristics listed are measured under the condition using the AUO Test inverter.

*2 In case of using an inverter other than listed, it is recommended to check the inverter carefully. Sometimes, interfering noise stripes appear on the screen, and substandard luminance or flicker at low power may happen.

*3 In designing an inverter, it is suggested to check safety circuit ver carefully. Impedance of CCFL, for instance, becomes more than 1 [M ohm] when CCFL is damaged.

*4 Generally, CCFL has some amount of delay time after applying start-up voltage. It is recommended to keep on applying start-up voltage for 1 [Sec] until discharge.

*5 The CCFL inverter operating frequency must be carefully chosen so that no interfering noise stripes on the screen were induced.

*6 Reducing CCFL current increases CCFL discharge voltage and generally increases CCFL discharge frequency. So all the parameters of an inverter should be carefully designed so as not to produce too much leakage current from high-voltage output of the inverter.

Note 2: It should be employed the inverter, which has “Duty Dimming”, if ICCFL is less than 4mA.

Note 3: The CCFL inverter operating frequency should be carefully determined to avoid interference between inverter and TFT LCD.

Note 4: The inverter open voltage should be designed larger than the lamp starting voltage at T=0°C, otherwise backlight may be blinking for a moment after turning on or not be able to turn on. The open voltage should be measured after ballast capacitor. If an inverter has shutdown function it should keep its open voltage for longer than 1 second even if lamp connector is open.

Note 5: Calculator value for reference (ICFL×VCFL=PCFL)

8.0 Interface Timings

Basically, interface timings should match the VESA 1024x768 /60Hz (VG901101) manufacturing guide line timing.

8.1 Timing Characteristics

Symbol	Description	Min	Typ	Max	Unit
fdck	DTCLK Frequency		65.00		[MHz]
tck	DTCLK cycle time		15.38		[nsec]
tx	X total time	1054	1344	2048	[tck]
tacx	X active time		1024		[tck]
tbkx	X blank time	30	320	1024	[tck]
Hsync	H frequency		48.36		[KHz]
Hsw	H-Sync width		136		[tck]
Hbp	H back porch		160		[tck]
Hfp	H front porch		24		[tck]
ty	Y total time	773	806	1024	[tx]
tacy	Y active time		768		[tx]
Vsync	Frame rate		60		[Hz]
Vw	V-sync Width		6		[tx]
Vfp	V-sync front porch		3		[tx]
Vbp	V-sync back porch		29		[tx]

Note: Hsw(H-sync width) + Hbp(H-sync back porch) should be less than 515 tck.

8.2 Timing Definition

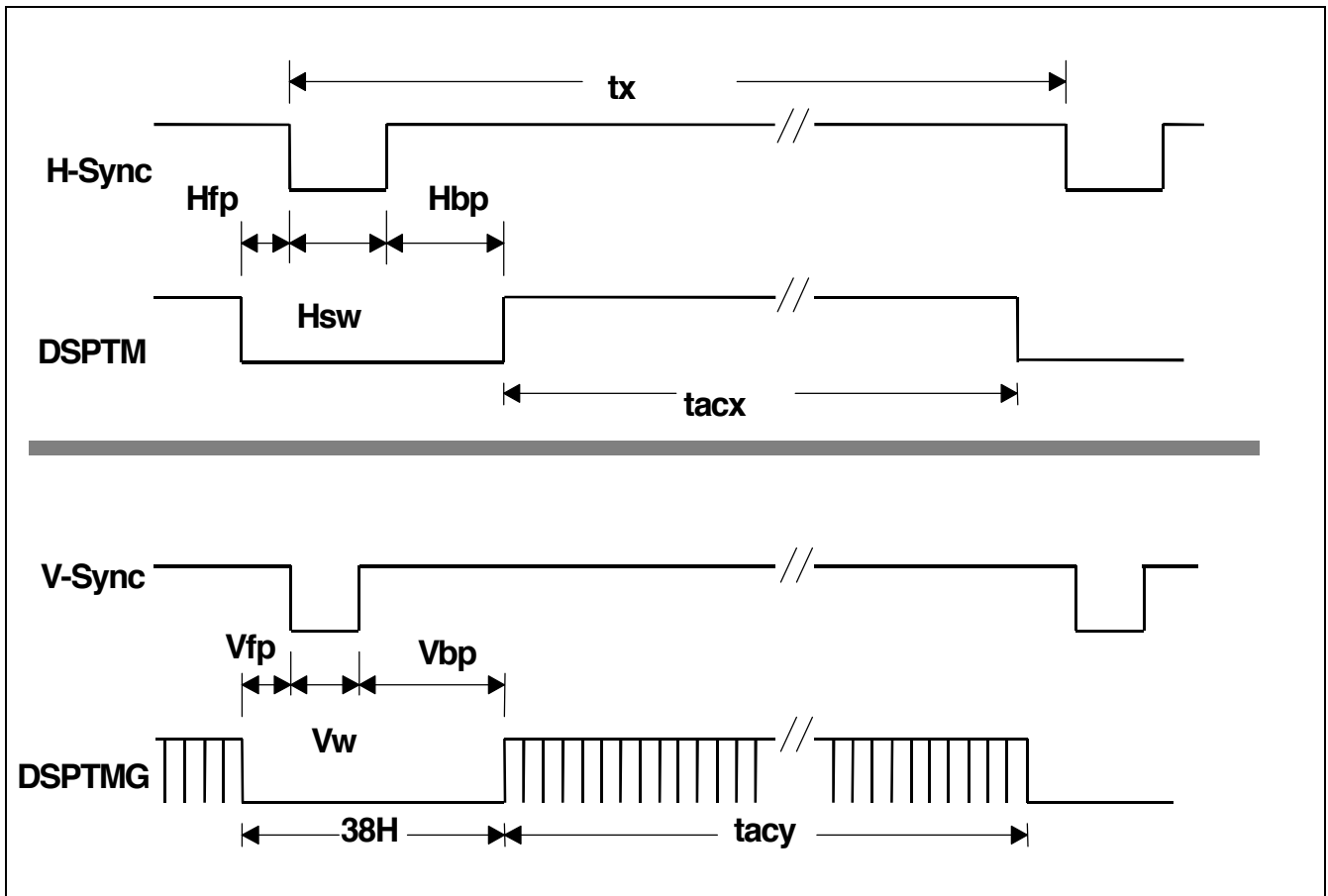

9.0 Power Consumption

Input power specifications are as follows:

Symbol	Parameter	Min	Typ	Max	Units	Condition
Module						
VDD	Logic/LCD Drive Voltage	3.0	3.3	3.6	[Volt]	Load Capacitance 20uF
PDD	VDD Power		1.4		[Watt]	All Black Pattern
PDD Max	VDD Power max			1.65	[Watt]	Max Pattern Note
IDD	IDD Current		350		mA	64 Grayscale Pattern
IDD Max	IDD Current max			450	mA	Vertical stripe line Pattern Note
VDDrp	Allowable Logic/LCD Drive Ripple Voltage			100	[mV] p-p	
VDDns	Allowable Logic/LCD Drive Ripple Noise			100	[mV] p-p	
Lamp						
ICFL	CCFL current	3.0	6.0	6.5	[mA] rms	(Ta=25°C)
VCFL	CCFL Voltage (Reference)	—	650	—	[Volt] rms	(Ta=25°C)
PCFL	CCFL Power consumption	—	3.9	—	[Watt]	(Ta=25°C)
Total Power Consumption	5.3 Watt (w/o Inverter, All black pattern)@LCM circuit 1.4 Watt(typ.),B/L input 3.9 Watt(typ.)					

Note : VDD=3.3V

10. Power ON/OFF Sequence

VDD power and lamp on/off sequence is as follows. Interface signals are also shown in the chart. Signals from any system shall be Hi-Z state or low level when VDD is off.

Sequence of Power-on/off and signal-on/off

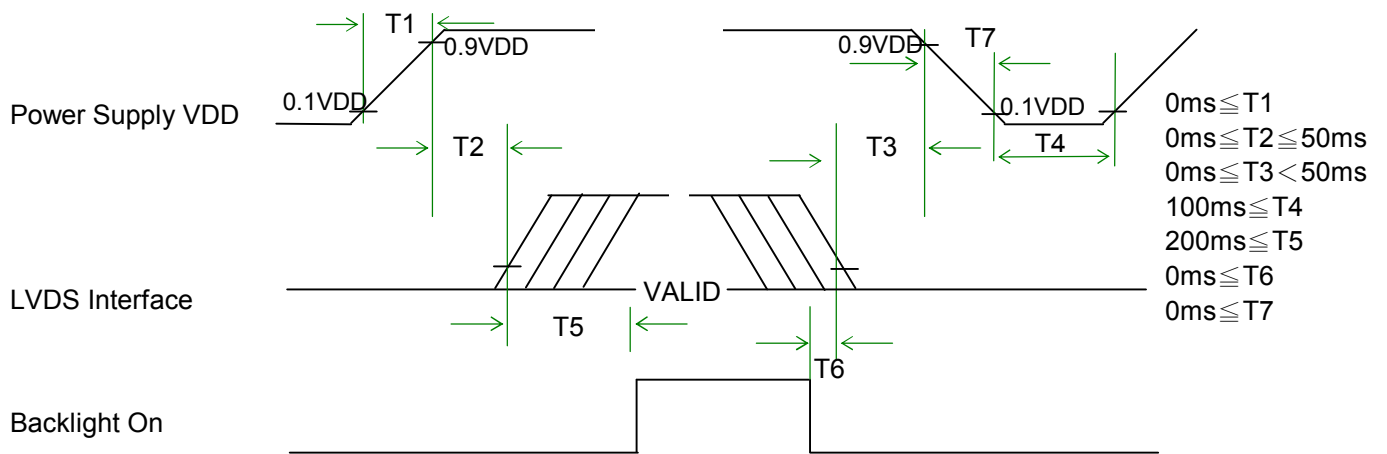

Apply the lamp voltage within the LCD operating range. When the backlight turns on before the LCD operation or the LCD turns off before the backlight turns off, the display may momentarily become abnormal.

11.0 Reliability /Safety Requirement

11.1 Reliability Test Conditions

Items	Required Condition
Temperature Humidity Bias	40°C/90%,300Hr
High Temperature Operation	50°C/Dry,300Hr
Low Temperature Operation	0°C,500Hr
Continuous Life	25°C ,2000 hours
On/Off Test	ON/30 sec. OFF/30sec., 30,000 cycles
Hot Storage	60°C/40% RH ,240 hours
Cold Storage	-20°C/50% RH ,240 hours
Thermal Shock Test	-20°C/30 min ,60°C/30 min 100cycles
Hot Start Test	50°C/1 Hr min. power on/off per 5 minutes, 5 times
Cold Start Test	0°C/1 Hr min. power on/off per 5 minutes, 5 times
Shock Test (Non-Operating)	240G, 2ms, Half-sine wave
Vibration Test (Non-Operating)	Sinusoidal vibration, 1.5G zero-to-peak, 10 to 500 Hz, 0.5 octave/minute in each of three mutually perpendicular axes.
ESD	Contact : operation ±8KV / non-operation ±10KV Air : operation ±15KV / non-operation ±20KV
Altitude Test	10000 ft / operation / 8Hr 30000ft / non-operation / 24r
Maximum Side Mount Torque	2.5kgf.cm .

CCFL Life : 10,000 hours minimum

MTBF(Excluding the CCFL) : 30,000 hours with a confidence level 90%

11.2 Safety

UL60950

11.3 Others

(1) Sound noise

There should be no uncomfortable noise.

Being used under whatever surrounds, when power on/off, the panel should not generate uncomfortable noise. And regarding specified values are negotiated if it is needed.

(2) Open / Short

No smoke, no fire at any open/ short test

(3) MTBF : 50,000 Hr (except for backlight lamp, Life time of lamp is longer than 10,000 hours)

(C) Copyright AU Optronics

Dec., 2002 All Rights Reserved.

B141XG09 V4

No Reproduction and Redistribution Allowed.

25/35

12.0 Packing Dimension

12.1 Packing method

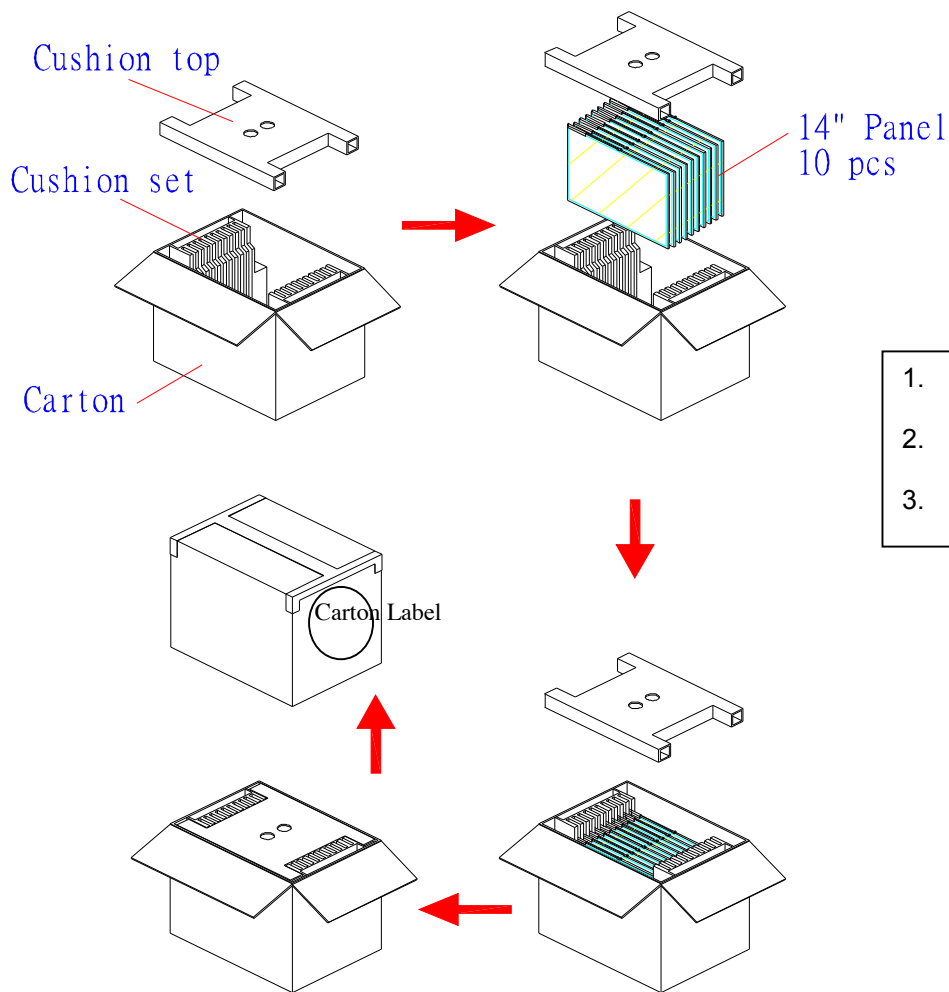

1. The panel of each LCD Module faces toward separation pad
2. Max. capacity: 10 LCD Modules/Carton
3. Dim: 365mm*265mm*335mm

12.2 Packing Specification

Item	Conditions
Packing Vibration	Frequency Range : 5 – 50 Hz, Degree of acceleration 1G(9.8 m/s ²). Sweep rate 3 minutes Top & Bottom 60 minutes, Right & Left 15 minutes, Back & Forth 15 minutes
Packing Drop Test	1 corner, 3 Edges, 6 Faces, Carton box weight (include LCDs) Dropping Height <10kg 75 cm 10-20< 55 cm 20-30< 45 cm

12.3 Package Label

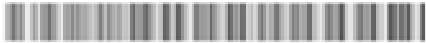
AU Optronic	QTY :10	RoHS	Pb
MODEL NO :	B141XG09 V4		
PART NO:	97.14B19.401		
CUSTOMER NO:	*G33C00038110*		
CARTON NO :			
	*ZS101-05A2850052		
Made in China			

12.4 Location of Package Label

Please refer to P.26

12.5 Panel Code Label on LCD

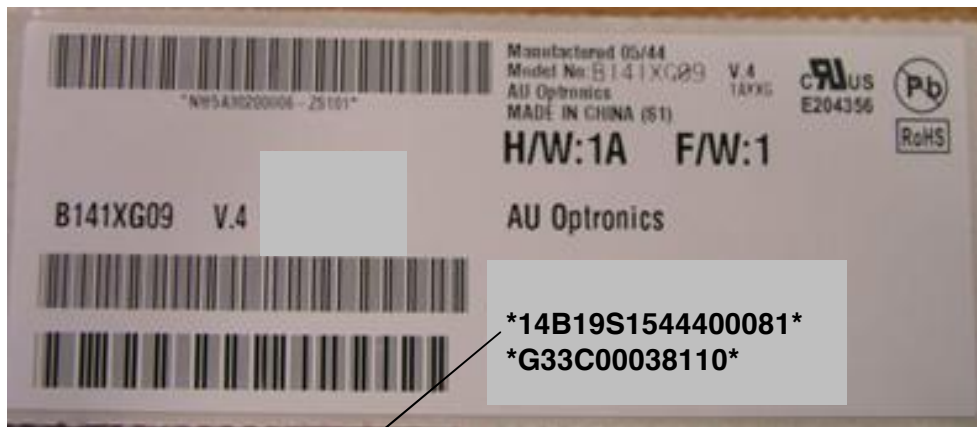

14B19 is Model Code
S1 is Factory Code
544 is Manufacture Date (first digit is year code, 2nd & 3rd digit are week code)
4 is Reversion No.
00081 is Series Code.

12.6 Location of Panel Label

Please refer to P.28

13.0 Mechanical Characteristics

13.1 LCM Outline dimension (Front View)

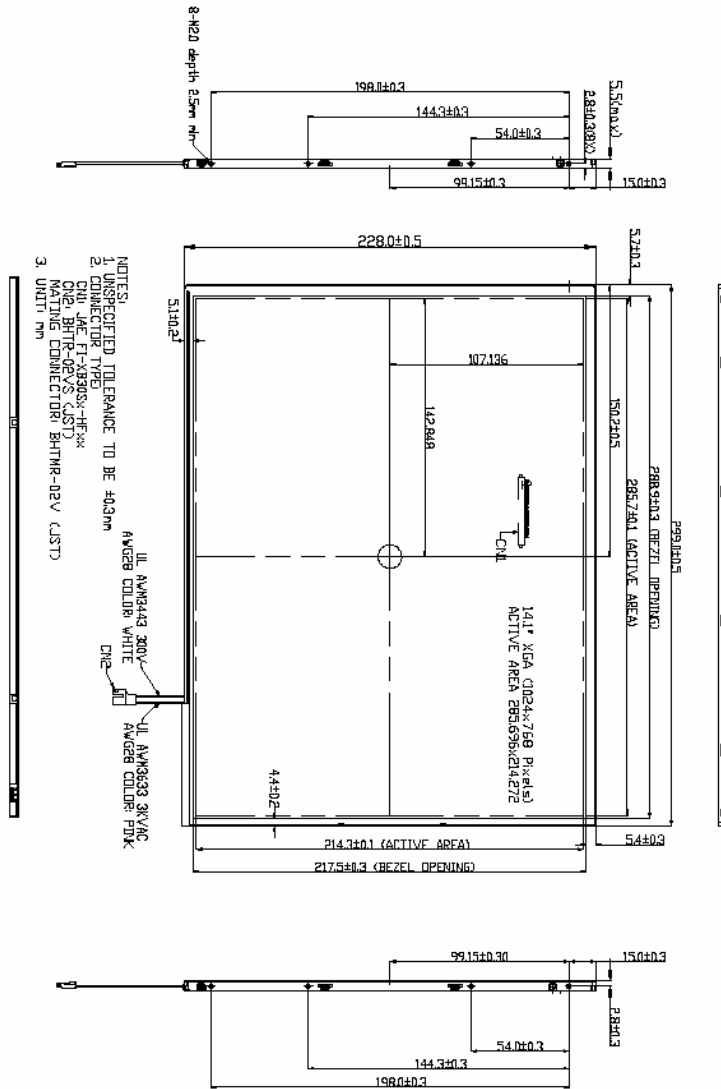

13.2 LCM Outline Dimension (Rear View)

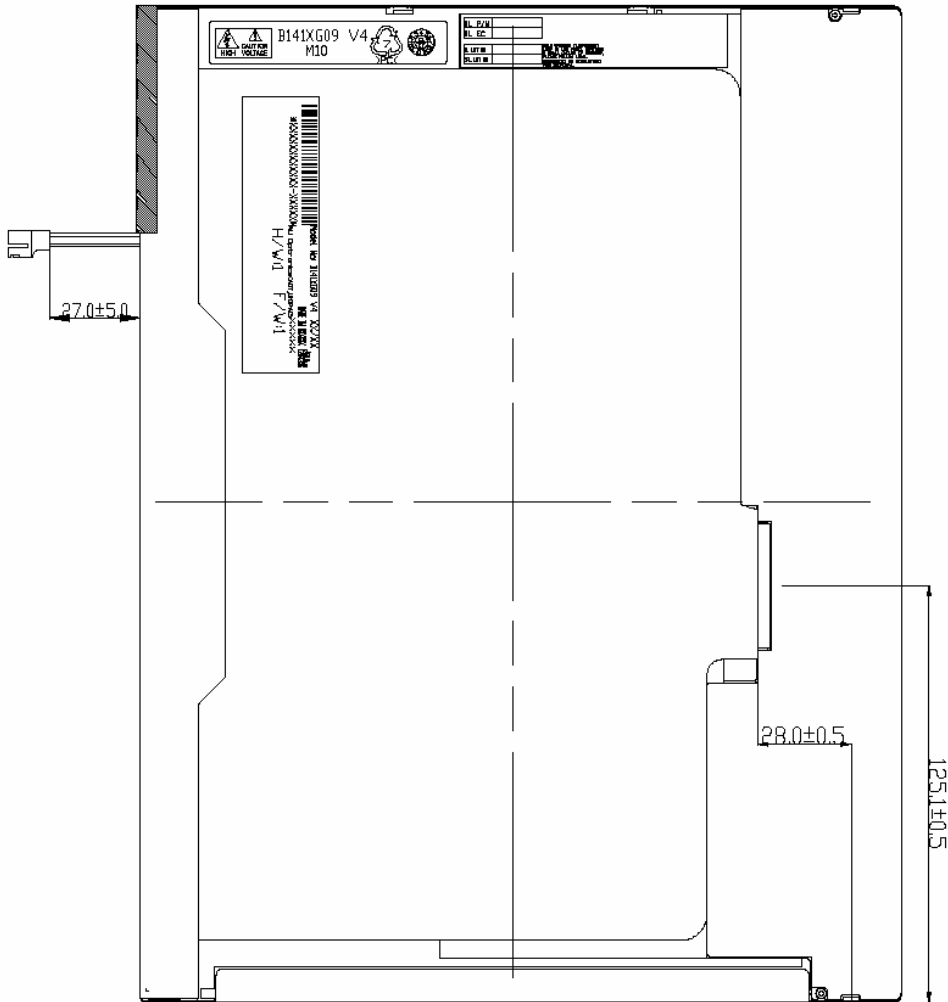

13.3 Screw Hole Depth and Center Position

Screw hole minimum depth, from side surface = 2.5 mm (See drawing)

Screw hole center location, from front surface = 2.8 ± 0.3 mm (See drawing)

Screw maximum length = 2.3 mm (See drawing)

Screw Torque: Maximum 2.5 kgf-cm

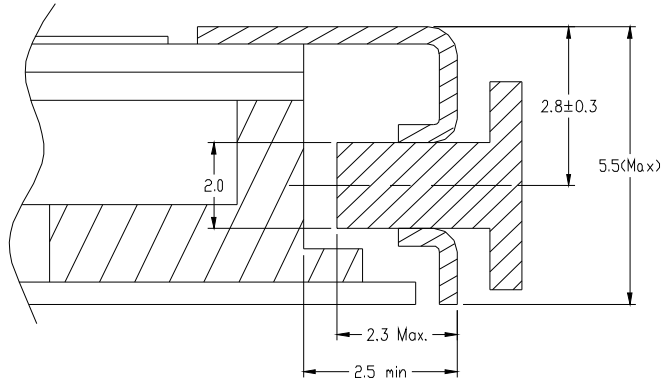

14.0 EDID

HEX	FUNCTION	Value HEX	Value BIN	Value DEC
00	Header	00	00000000	0
01		FF	11111111	255
02		FF	11111111	255
03		FF	11111111	255
04		FF	11111111	255
05		FF	11111111	255
06		FF	11111111	255
07		00	00000000	0
08	EISA Manuf. Code LSB	06	00000110	6
09	Compressed ASCII	AF	10101111	175
0A	Product Code	41	01000001	65
0B	hex, LSB first	94	10010100	148
0C	32-bit ser #	00	00000000	0
0D		00	00000000	0
0E		00	00000000	0
0F		00	00000000	0
10	Week of manufacture	01	00000001	1
11	Year of manufacture	0E	00001110	14
12	EDID Structure Ver.	01	00000001	1
13	EDID revision #	03	00000011	3
14	Video input definition	80	10000000	128
15	Max H image size	1D	00011101	29
16	Max V image size	15	00010101	21
17	Display Gamma	78	01111000	120
18	Feature support	0A	00001010	10
19	Red/green low bits	47	01000111	71
1A	Blue/white low bits	95	10010101	149
1B	Red x/ high bits	94	10010100	148
1C	Red y	57	01010111	87
1D	Green x	4F	01001111	79
1E	Green y	8C	10001100	140
1F	Blue x	26	00100110	38
20	Blue y	21	00100001	33
21	White x	50	01010000	80
22	White y	54	01010100	84
23	Established timing 1	00	00000000	0
24	Established timing 2	00	00000000	0
25	Manufacturer's Timing	00	00000000	0

(C) Copyright AU Optronics

Dec., 2002 All Rights Reserved.

B141XG09 V4

No Reproduction and Redistribution Allowed.

26	Standard timing #1	01	00000001	1
27		01	00000001	1
28	Standard timing #2	01	00000001	1
29		01	00000001	1
2A	Standard timing #3	01	00000001	1
2B		01	00000001	1
2C	Standard timing #4	01	00000001	1
2D		01	00000001	1
2E	Standard timing #5	01	00000001	1
2F		01	00000001	1
30	Standard timing #6	01	00000001	1
31		01	00000001	1
32	Standard timing #7	01	00000001	1
33		01	00000001	1
34	Standard timing #8	01	00000001	1
35		01	00000001	1
36	Pixel Clock/10,000 (LSB)	64	01100100	100
37	Pixel Clock/10,000 (MSB)	19	00011001	25
38	Horiz. Active pixels(Lower 8 bits)	00	00000000	0
39	Horiz.Blanking (Lower 8 bits)	40	01000000	64
3A	Horiz. Active pixels:Horiz. Blanking (Upper4:4 bits)	41	01000001	65
3B		00	00000000	0
3C		26	00100110	38
3D	Vert. Active pixels:Vert. Blanking (Upper4:4 bits)	30	00110000	48
3E		18	00011000	24
3F		88	10001000	136
40	Vert. Sync. Offset=xx lines, Sync Width=xx lines	36	00110110	54
41	Horz. Ver. Sync/Width (upper 2 bits)	00	00000000	0
42	Hori. Image size (Lower 8 bits)	1E	00011110	30
43	Vert. Image size (Lower 8 bits)	D6	11010110	214
44	Hori. Image size : Vert. Image size (Upper 4 bits)	10	00010000	16
45		00	00000000	0
46		00	00000000	0
47		18	00011000	24
48	Detailed timing/monitor	00	00000000	0
49	descriptor #2	00	00000000	0
4A		00	00000000	0
4B		FE	11111110	254
4C		00	00000000	0

(C) Copyright AU Optronics

Dec., 2002 All Rights Reserved.

B141XG09 V4

No Reproduction and Redistribution Allowed.

4D		00	00000000	0
4E		00	00000000	0
4F		00	00000000	0
50		00	00000000	0
51		00	00000000	0
52		00	00000000	0
53		00	00000000	0
54		00	00000000	0
55		00	00000000	0
56		00	00000000	0
57		00	00000000	0
58		00	00000000	0
59		20	00100000	32
5A	Flag	00	00000000	0
5B	Flag	00	00000000	0
5C	Flag	00	00000000	0
5D		FE	11111110	254
5E		00	00000000	0
5F	A	41	01000001	65
60	U	55	01010101	85
61	O	4F	01001111	79
62		0A	00001010	10
63		20	00100000	32
64		20	00100000	32
65		20	00100000	32
66		20	00100000	32
67		20	00100000	32
68		20	00100000	32
69		20	00100000	32
6A		20	00100000	32
6B		20	00100000	32
6C	Flag	00	00000000	0
6D	Flag	00	00000000	0
6E	Flag	00	00000000	0
6F	Data type tag:ASCII string	FE	11111110	254
70	Flag	00	00000000	0
71		42	01000010	66
72		31	00110001	49
73		34	00110100	52
74		31	00110001	49
75		58	01011000	88

76		47	01000111	71
77		30	00110000	48
78		39	00111001	57
79		20	00100000	32
7A		56	01010110	86
7B		34	00110100	52
7C		20	00100000	32
7D		0A	00001010	10
7E	Extension Flag	00	00000000	0
7F	Checksum	75	01110101	117