



## Product Specification

AU OPTRONICS CORPORATION

( ) Preliminary Specifications

(V) Final Specifications

<b>Module</b>	15.4" WXGA+ Color TFT-LCD
<b>Model Name</b>	B154PW04 V3
<b>Dell P/N</b>	HW663

<b>Customer</b>	<b>Date</b>
_____	_____
 <b>Checked &amp; Approved by</b>	<b>Date</b>
_____	_____

<b>Approved by</b>	<b>Date</b>
_____	_____
<b>Prepared by</b>	<b>Date</b>
_____	_____

Note: This Specification is subject to change without notice.

**NBBU Marketing Division /  
AU Optronics corporation**



# Product Specification

AU OPTRONICS CORPORATION

## Contents

<b>1. Handling Precautions</b>	<b>4</b>
<b>2. General Description</b>	<b>5</b>
2.1 General Specification	5
2.2 Optical Characteristics	6
<b>3. Functional Block Diagram</b>	<b>11</b>
<b>4. Absolute Maximum Ratings</b>	<b>12</b>
4.1 Absolute Ratings of TFT LCD Module	12
4.2 Absolute Ratings of Backlight Unit	12
4.3 Absolute Ratings of Environment	12
<b>5. Electrical characteristics</b>	<b>13</b>
5.1 TFT LCD Module	13
5.2 Backlight Unit	15
<b>6. Signal Characteristic</b>	<b>18</b>
6.1 Pixel Format Image	18
6.2 The input data format	19
6.3 Signal Description/Pin Assignment	20
6.4 Interface Timing	22
6.5 Power ON/OFF Sequence	24
<b>7. Connector Description</b>	<b>25</b>
7.1 TFT LCD Module	25
<b>8. Dynamic Test</b>	<b>26</b>
8.1 Vibration Test	26
8.2 Shock Test Spec:	26
<b>9. Reliability</b>	<b>27</b>
<b>10. Mechanical Characteristics</b>	<b>28</b>
10.1 LCM Outline Dimension	28
10.2 Screw Hole Depth and Center Position	30
<b>11. Shipping and Package</b>	<b>31</b>
11.1 Shipping Label Format	31
11.2 Definition of customer PPID Label and Revision Code	31
11.3 Carton package	32
<b>12. Appendix: EDID description</b>	<b>33</b>



## Product Specification

AU OPTRONICS CORPORATION

### Record of Revision

Version and Date	Page	Old description	New Description	Remark
0.1 2007/10/26	All	First Edition for Customer		
0.2 2007/10/27	27	No back side drawing	Add back side drawing	
0.3 2007/11/29	16, 30	No LED power sequence No 15 years environmentally safety period mark	Add LED power sequence Change Shipping Label Format and adds 15 years environmentally safety period mark	
0.4 2007/12/10	17	No LED Driver Pull-up resistor	Add LED Driver Pull-up resistor	
0.5 2007/12/28	31	1D Label	Change to 2D Label	
06 2008/1/11	29	original position of connector	Changed position of connector	
07 2008/4/08	33-36	original EDID	EDID for A00	
08 2008/4/30	6	Chromaticity of color is $\pm 0.02$	Chromaticity of color modify to $\pm 0.03$	



### 1. Handling Precautions

- 1) Since front polarizer is easily damaged, pay attention not to scratch it.
- 2) Be sure to turn off power supply when inserting or disconnecting from input connector.
- 3) Wipe off water drop immediately. Long contact with water may cause discoloration or spots.
- 4) When the panel surface is soiled, wipe it with absorbent cotton or other soft cloth.
- 5) Since the panel is made of glass, it may break or crack if dropped or bumped on hard surface.
- 6) Since CMOS LSI is used in this module, take care of static electricity and insure human earth when handling.
- 7) Do not open nor modify the Module Assembly.
- 8) Do not press the reflector sheet at the back of the module to any directions.
- 9) In case if a Module has to be put back into the packing container slot after once it was taken out from the container, do not press the center of the LED lamp Reflector edge. Instead, press at the far ends of the LED lamp Reflector edge softly. Otherwise the TFT Module may be damaged.
- 10) At the insertion or removal of the Signal Interface Connector, be sure not to rotate nor tilt the Interface Connector of the TFT Module.
- 11) After installation of the TFT Module into an enclosure (Notebook PC Bezel, for example), do not twist nor bend the TFT Module even momentary. At designing the enclosure, it should be taken into consideration that no bending/twisting forces are applied to the TFT Module from outside. Otherwise the TFT Module may be damaged.
- 12) Small amount of materials having no flammability grade is used in the LCD module. The LCD module should be supplied by power complied with requirements of Limited Power Source (IEC60950 or UL1950), or be applied exemption.
- 13) The LCD module is designed so that the LED in it is supplied by Limited Current Circuit (IEC60950 or UL1950). Do not connect the LED in Hazardous Voltage Circuit.



## Product Specification

AU OPTRONICS CORPORATION

### 2. General Description

B154PW04 V3 is a Color Active Matrix Liquid Crystal Display composed of a TFT LCD panel, a driver circuit, and backlight system. The screen format is intended to support the WXGA+ (1440(H) x 900(V)) screen and 262k colors (RGB 6-bits data driver) without backlight inverter. All input signals are LVDS interface compatible.

B154PW04 V3 is designed for a display unit of notebook style personal computer and industrial machine.

### 2.1 General Specification

The following items are characteristics summary on the table at 25 °C condition:

Items	Unit	Specifications			
Screen Diagonal	[mm]	391 (15.4W")			
Active Area	[mm]	331.560 (H) X 207.225 (V)			
Pixels H x V		1440x3(RGB) x 900			
Pixel Pitch	[mm]	0.23025X0.23025			
Pixel Format		R.G.B. Vertical Stripe			
Display Mode		Normally White			
White Luminance (ILED=19mA) Note: ILED is lamp current	[cd/m <sup>2</sup> ]	300 typ.(5 points average) 270 min.(5 points average) (Note1)			
Luminance Uniformity		1.25 max. (5 points) 1.53 max. (13 points)			
Contrast Ratio		600 typ			
Response Time	[ms]	16 typ			
Nominal Input Voltage VDD	[Volt]	+3.3 typ.			
Power Consumption	[Watt]	5.8 max.			
Weight	[Grams]	460 max.			
Physical Size	[mm]		L	W	T
		Max	344.5	222.5	6.1
		Typical	344.0	222.0	-
		Min	343.5	221.5	-
Electrical Interface		Dual channel LVDS			
Surface Treatment		Glare, Hardness 3H,			



## Product Specification

AU OPTRONICS CORPORATION

Support Color		262K colors ( RGB 6-bit )
Temperature Range Operating Storage (Non-Operating)	[°C] [°C]	0 to +50 -25 to +65
RoHS Compliance		RoHS Compliance

### 2.2 Optical Characteristics

The optical characteristics are measured under stable conditions at 25°C (Room Temperature) :

Item	Unit	Conditions	Min.	Typ.	Max.	Note
White Luminance I <sub>LED</sub> =19mA	[cd/m <sup>2</sup> ]	5 points average	270	300	-	1, 4, 5.
Viewing Angle	[degree]	Horizontal (Right) CR = 10 (Left)	55	60	-	8
	[degree]		55	60	-	
	[degree] [degree]	Vertical (Upper) CR = 10 (Lower)	45 45	50 55	- -	
Luminance Uniformity		5 Points	-	-	1.25	1
Luminance Uniformity		13 Points	-	-	1.53	2
CR: Contrast Ratio			500	600	-	6
Cross talk	%				4	7
Response Time	[msec]	Rising	-	4	8	8
	[msec]	Falling	-	12	17	
	[msec]	Rising + Falling	-	16	25	
Chromaticity of color Coordinates (CIE 1931)		Red x	0.570	0.600	0.630	2,8
		Red y	0.315	0.345	0.375	
		Green x	0.290	0.320	0.350	
		Green y	0.525	0.555	0.585	
		Blue x	0.120	0.150	0.180	
		Blue y	0.090	0.120	0.150	
		White x	0.283	0.313	0.343	
	White y	0.299	0.329	0.359		
NTSC	%	CIE 1931	-	45	-	



# Product Specification

AU OPTRONICS CORPORATION

Note 1: 5 points position (Ref: Active area)

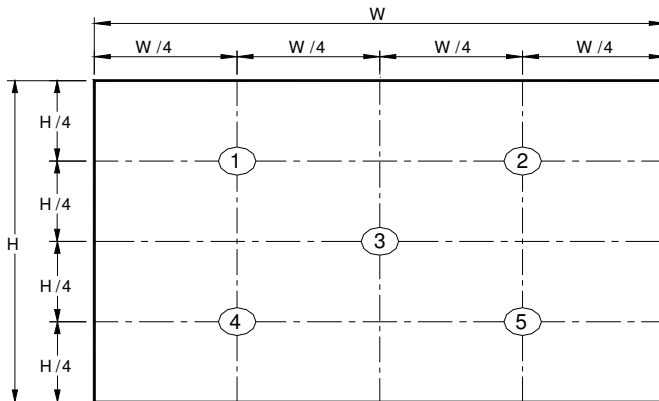

Note 2: 13 points position (Ref: Active area)

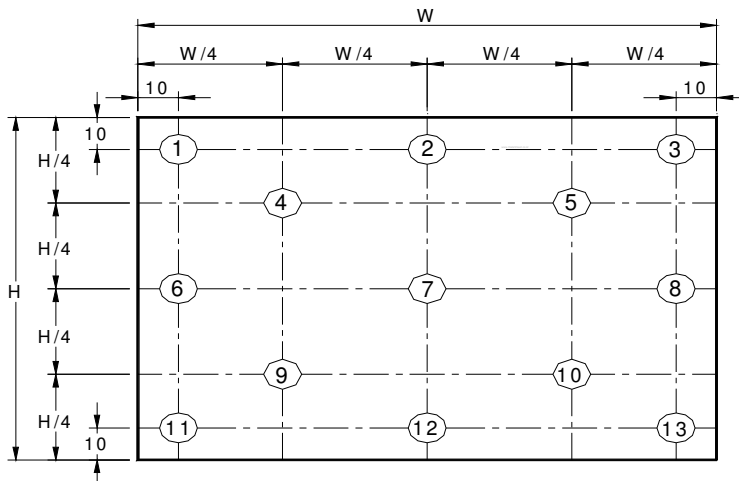

Note 3: The luminance uniformity of 5 or 13 points is defined by dividing the maximum luminance values by the minimum test point luminance

$$\delta_{W5} = \frac{\text{Maximum Brightness of five points}}{\text{Minimum Brightness of five points}}$$

$$\delta_{W13} = \frac{\text{Maximum Brightness of thirteen points}}{\text{Minimum Brightness of thirteen points}}$$

Note 4: Measurement method

The LCD module should be stabilized at given temperature for 30 minutes to avoid abrupt temperature change during measuring. In order to stabilize the luminance, the measurement should be executed after lighting Backlight for 30 minutes in a stable, windless and dark room.

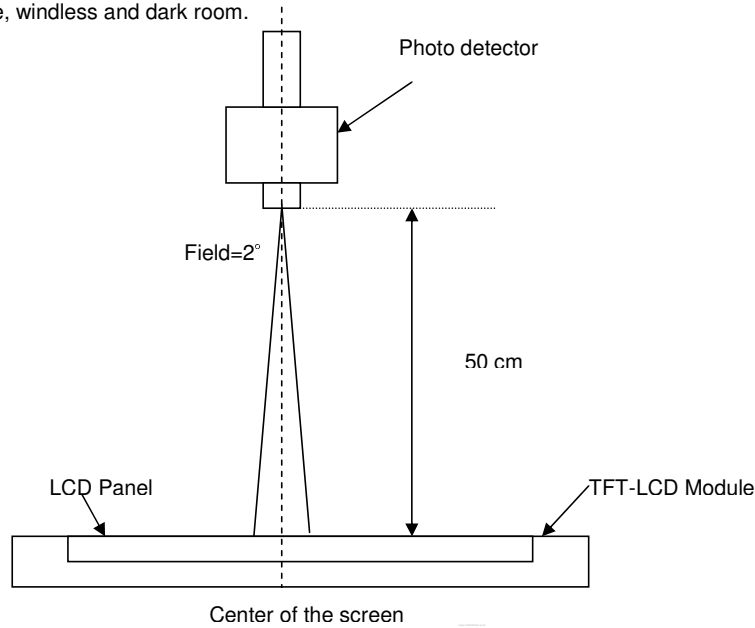

Note 5 : Definition of Average Luminance of White ( $Y_L$ ):

Measure the luminance of gray level 63 at 5 points ·  $Y_L = [L (1)+ L (2)+ L (3)+ L (4)+ L (5)] / 5$

$L (x)$  is corresponding to the luminance of the point X at Figure in Note (1).

Note 6 : Definition of contrast ratio:

Contrast ratio is calculated with the following formula.

$$\text{Contrast ratio (CR)} = \frac{\text{Brightness on the "White" state}}{\text{Brightness on the "Black" state}}$$

Note 7 : Definition of Cross Talk (CT)

$$CT = |Y_B - Y_A| / Y_A \times 100 (\%)$$

Where

$Y_A$  = Luminance of measured location without gray level 0 pattern (cd/m<sup>2</sup>)





# Product Specification

AU OPTRONICS CORPORATION

$Y_B$  = Luminance of measured location with gray level 0 pattern (cd/m<sup>2</sup>)

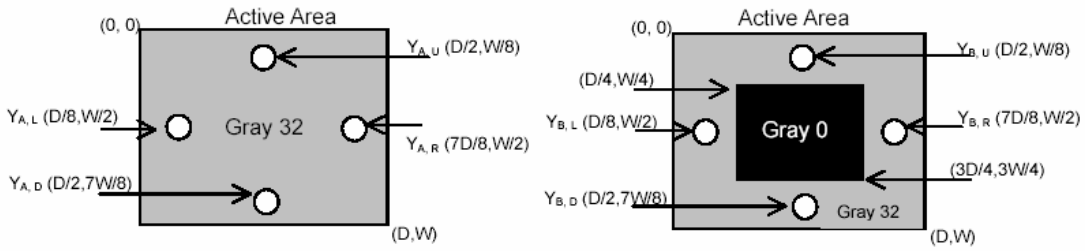

Note 8: Definition of response time:

The output signals of BM-7 or equivalent are measured when the input signals are changed from "Black" to "White" (falling time) and from "White" to "Black" (rising time), respectively. The response time interval between the 10% and 90% of amplitudes. Refer to figure as below.

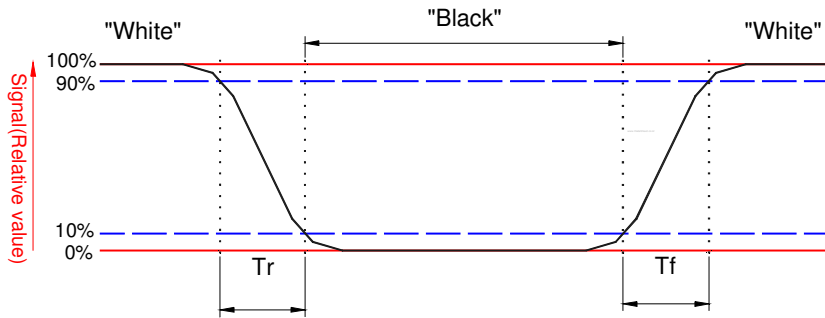

Note 8. Definition of viewing angle

Viewing angle is the measurement of contrast ratio  $\geq 10$ , at the screen center, over a  $180^\circ$  horizontal and  $180^\circ$  vertical range (off-normal viewing angles). The  $180^\circ$  viewing angle range is broken down as follows;  $90^\circ$  ( $\theta$ ) horizontal left and right and  $90^\circ$  ( $\Phi$ ) vertical, high (up) and low (down). The measurement direction is typically perpendicular to the display surface with the screen rotated about its center to develop the desired measurement viewing angle.

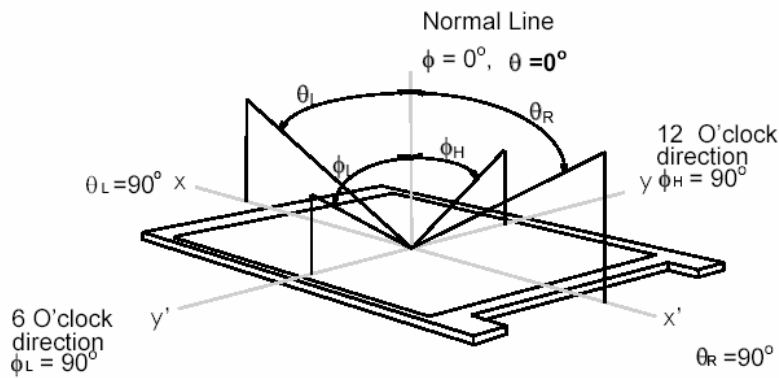



# Product Specification

AU OPTRONICS CORPORATION

## 3. Functional Block Diagram

The following diagram shows the functional block of the 15.4 inches wide Color TFT/LCD Module:

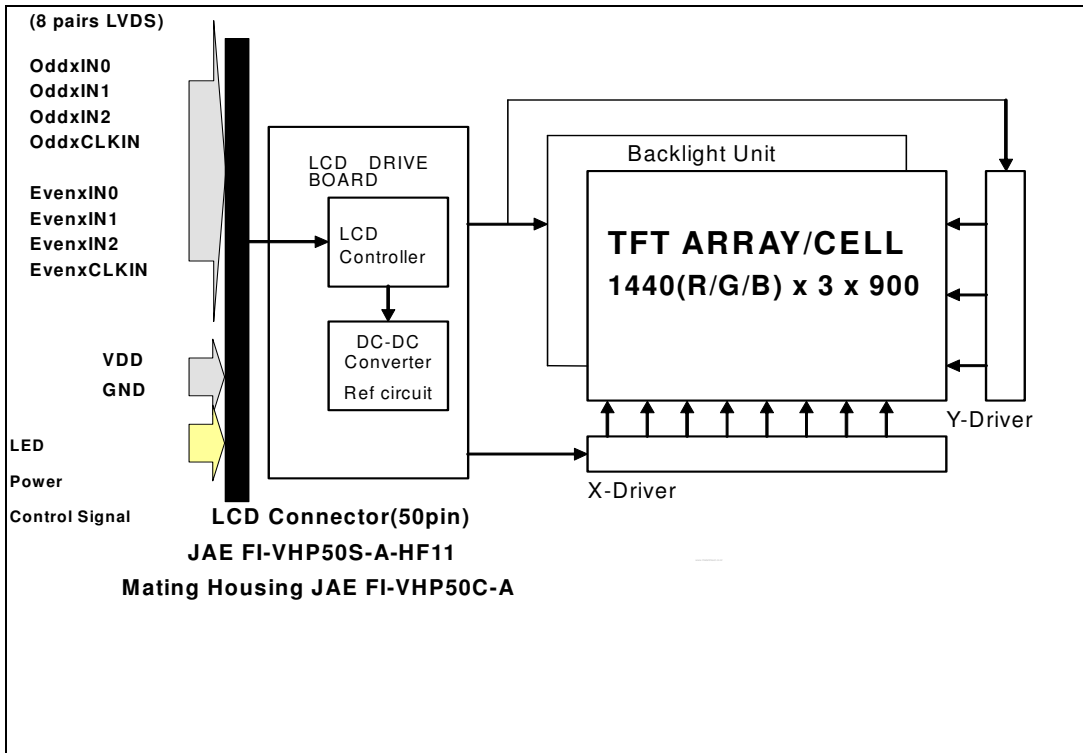



# Product Specification

AU OPTRONICS CORPORATION

## 4. Absolute Maximum Ratings

An absolute maximum rating of the module is as following:

### 4.1 Absolute Ratings of TFT LCD Module

Item	Symbol	Min	Max	Unit	Conditions
Logic/LCD Drive Voltage	Vin	-0.3	+4.0	[Volt]	Note 1,2

### 4.2 Absolute Ratings of Backlight Unit

Item	Symbol	Min	Max	Unit	Conditions
LED Current	ILED	-	20	[mA] rms	Note 1,2

### 4.3 Absolute Ratings of Environment

Item	Symbol	Min	Max	Unit	Conditions
Operating Temperature	TOP	0	+50	[°C]	Note 3
Operation Humidity	HOP	5	95	[%RH]	Note 3
Storage Temperature	TST	-20	+60	[°C]	Note 3
Storage Humidity	HST	5	95	[%RH]	Note 3

Note 1: At Ta (25°C )

Note 2: Permanent damage to the device may occur if exceed maximum values

**Note 3: For quality performance, please refer to AUO IIS (Incoming Inspection Standard).**

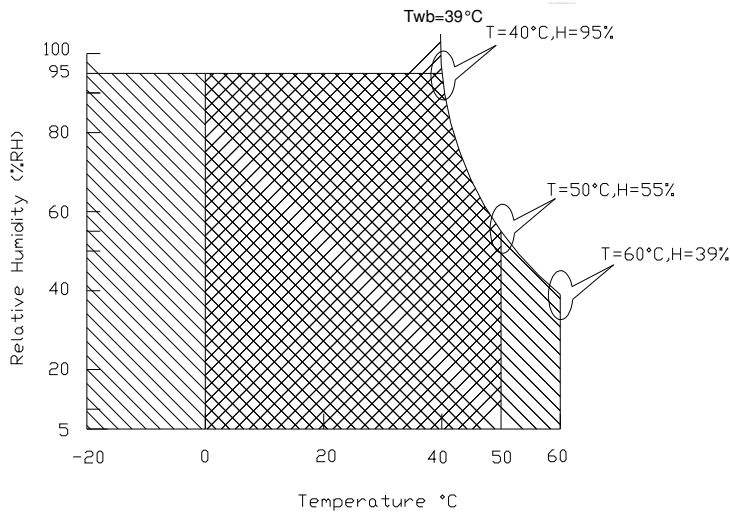

Operating Range Storage Range +

## 5. Electrical characteristics

### 5.1 TFT LCD Module

#### 5.1.1 Power Specification

Input power specifications are as follows;

Symble	Parameter	Min	Typ	Max	Units	Note
VDD	Logic/LCD Drive Voltage	3.0	3.3	3.6	[Volt]	
PDD	VDD Power	-	-	2	[Watt]	Note 1/2
IDD	IDD Current	-	380	562	[mA]	Note 1/2
IRush	Inrush Current	-	-	2000	[mA]	Note 3
VDDrp	Allowable Logic/LCD Drive Ripple Voltage	-	-	100	[mV] p-p	

Note 1 : Maximum Measurement Condition : Black Pattern

Note 2 : Typical Measurement Condition: Mosaic Pattern

Note 3 : Measure Condition

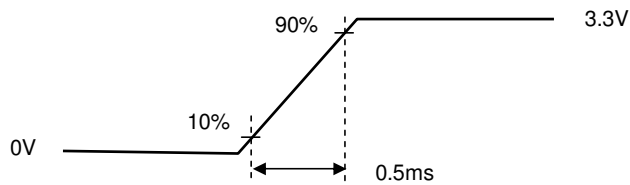
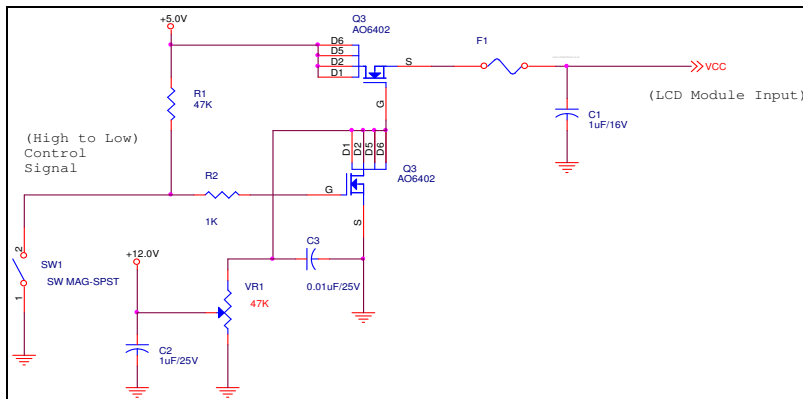

Vin rising time

## 5.1.2 Signal Electrical Characteristics

Input signals shall be low or High-impedance state when VDD is off.

It is recommended to refer the specifications of THC63LVDF84A (Thine Electronics Inc.) in detail.

Signal electrical characteristics are as follows;

Parameter	Condition	Min	Max	Unit
Vth	Differential Input High Threshold (Vcm=+1.2V)	-	100	[mV]
Vtl	Differential Input Low Threshold (Vcm=+1.2V)	-100	-	[mV]
Vcm	Differential Input Common Mode Voltage	1.1	1.45	[V]

Note: LVDS Signal Waveform

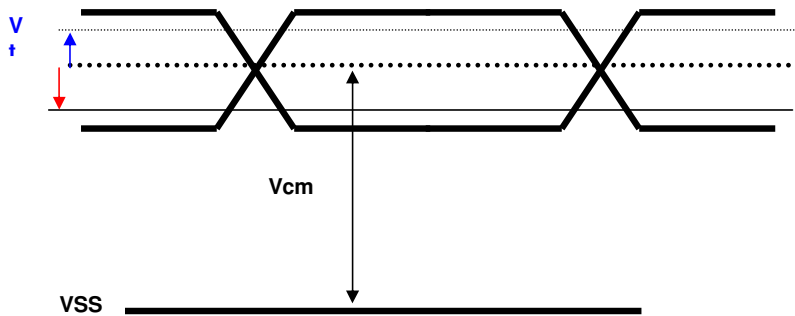



# Product Specification

AU OPTRONICS CORPORATION

## 5.2 Backlight Unit

The BLU system is an edge type light source with LED (Light Emitting Diode) light bar

Item	Symbol	Min	Typ	Max	Units	Condition
Fixed input current	ILt			20	[mA] rms	
Light bar Voltage	VL		32.	34	[Volt] rms	
Light bar Power	PL		3.7	3.88	Wt	

Light bar PIN assignment:

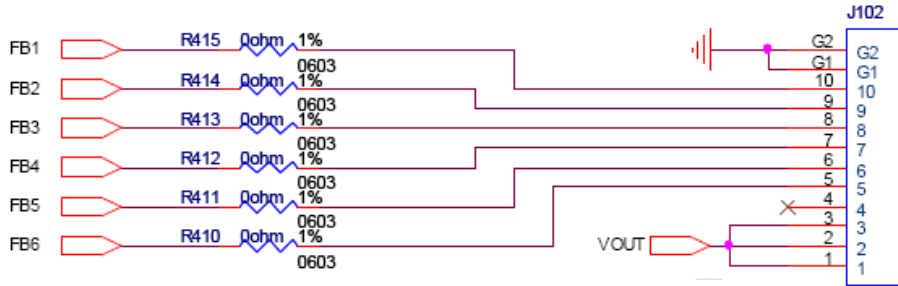

PIN NO.	Pin assignment	Function
1	VOUT	LED Anode (Positive)
2	VOUT	LED Anode (Positive)
3	VOUT	LED Anode (Positive)
4	NC	NC
5	FB6	LED Cathode (Negative)
6	FB5	LED Cathode (Negative)
7	FB4	LED Cathode (Negative)
8	FB3	LED Cathode (Negative)
9	FB2	LED Cathode (Negative)
10	FB1	LED Cathode (Negative)



# Product Specification

AU OPTRONICS CORPORATION

## LED Power Sequence

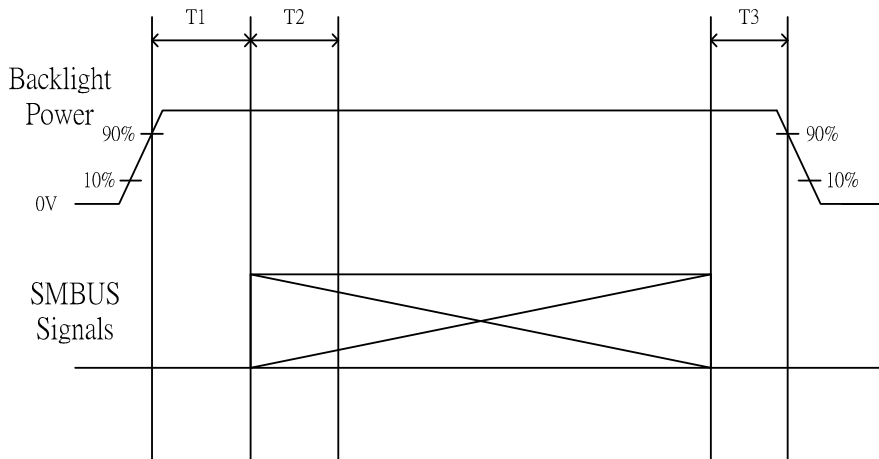

Symbol	Value			Unit
	Min	Typ	Max	
T1	10	--	--	ms
T2	100	--	--	ms
T3	10	--	--	ms

Note: The duty of LED dimming signal should be more than 20% in T2..



## LED Driver SMBUS Pull-up resistor

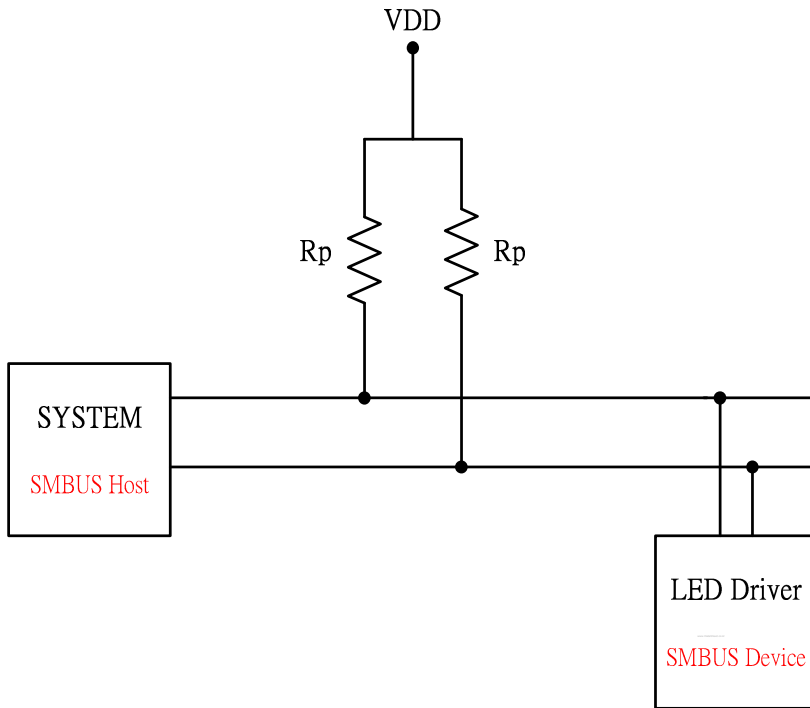

SMBUS Pull-up Circuitry

### Setting value for Pull-up resistor $R_p$

$$(VDD - 0.4)/(100 * 10^{-6}) \geq R_p \geq (VDD - 0.4)/(350 * 10^{-6})$$

**Suggestion:** IF VDD=3.3V,  $R_p=10K$  ohm; IF VDD=5V,  $R_p=15K$  ohm

Note:  $R_p$  is the equivalent resistor for SMBUS Pull-up Circuitry

## 6. Signal Characteristic

### 6.1 Pixel Format Image

Following figure shows the relationship of the input signals and LCD pixel format.

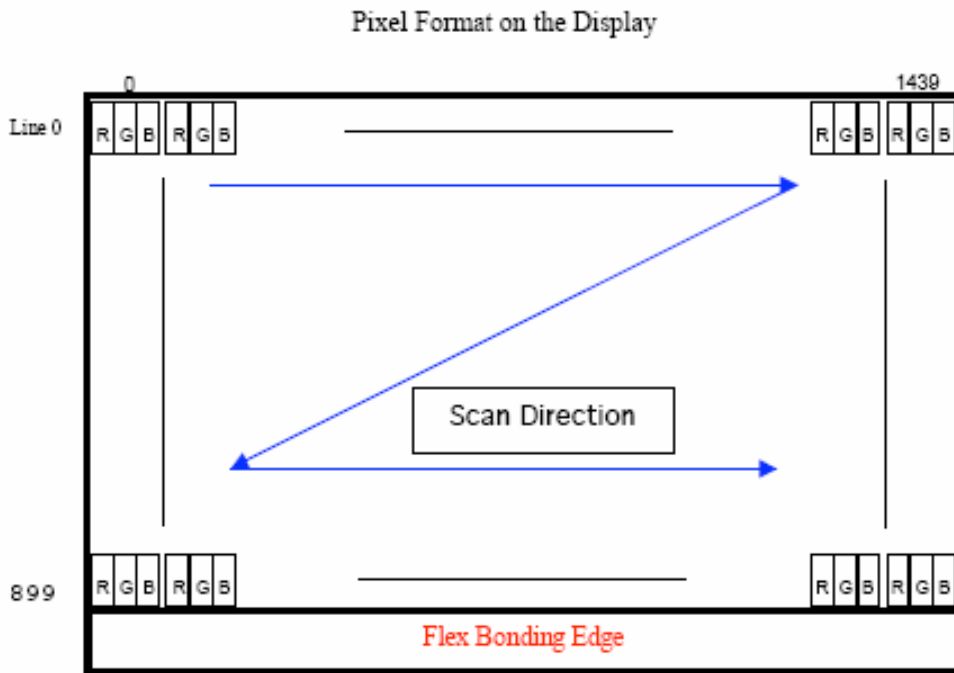

## 6.2 The input data format

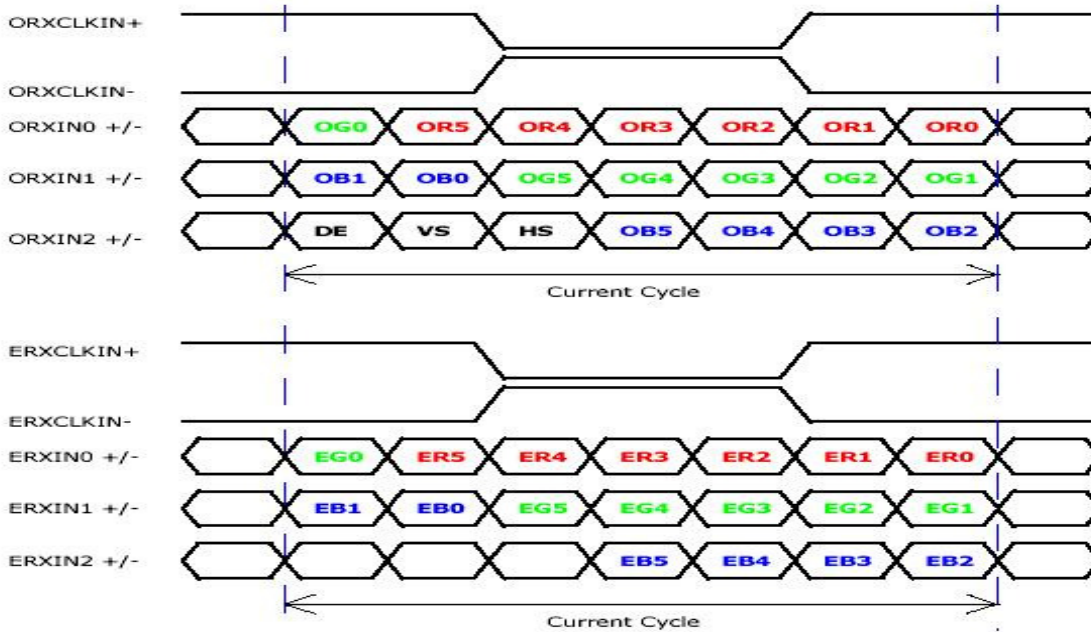

Signal Name	Description
<b>VEEDID (3.3V)</b>	<b>+3.3V EDID Power</b>
<b>CLK EEDID</b>	<b>EDID Clock Input</b>
<b>DATA EEDID</b>	<b>EDID Data Input</b>
ORXIN0-, ORXIN0+	Odd LVDS differential data input(ORed0-ORed5, OGreen0)
ORXIN1-, ORXIN1+	Odd LVDS differential data input(OGreen1-OGreen5, OBlue0-OBue1)
ORXIN2-, ORXIN2+	Odd LVDS differential data input(OBlue2-OBue5, Hsync, Vsync, DE)
ORXCLKIN-, ORXCLKIN+	Odd LVDS differential clock input
ERXIN0-, ERXIN0+	Even LVDS differential data input(ERed0-ERed5, EGreen0)
ERXIN1-, ERXIN1+	Even LVDS differential data input(EGreen1-EGreen5, EBlue0-EBlue1)
ERXIN2-, ERXIN2+	Even LVDS differential data input(EBlue2-EBlue5)
ERXCLKIN-, ERXCLKIN+	Even LVDS differential clock input
VDD	+3.3V Power Supply
VSS	<b>Ground</b>

Note: Output signals from any system shall be low or High-impedance state when VDD is off.

## 6.3 Signal Description/Pin Assignment

LVDS is a differential signal technology for LCD interface and high speed data transfer device.

PIN#	Signal Name	Description	
1	Test Loop (only to pin 30)	Diag. pin for test	
2	VEEDID (3.3v)	DDC 3.3Vpower	
3	VSS	Ground	
4	CLK EEDID	DDC Clock	
5	DATA EEDID	DDC Data	
6	VSS	Ground	
7	Odd_Rin0-	Odd channel Differential Data Input	
8	Odd_Rin0+	Odd channel Differential Data Input	
9	VSS	Ground	
10	Odd_Rin1-	Odd channel Differential Data Input	
11	Odd_Rin1+	Odd channel Differential Data Input	
12	VSS	Ground	
13	Odd_Rin2-	Odd channel Differential Data Input	
14	Odd_Rin2+	Odd channel Differential Data Input	
15	VSS	Ground	
16	Odd_ClkIN-	Odd channel Differential Clock Input	
17	Odd_ClkIN+	Odd channel Differential Clock Input	
18	VSS	Ground	
19	Even_Rin0-	Even channel Differential Data Input	
20	Even_Rin0+	Even channel Differential Data Input	
21	VSS	Ground	
22	Even_Rin1-	Even channel Differential Data Input	
23	Even_Rin1+	Even channel Differential Data Input	
24	VSS	Ground	
25	Even_Rin2-	Even channel Differential Data Input	
26	Even_Rin2+	Even channel Differential Data Input	
27	VSS	Ground	
28	Even_ClkIN-	Even channel Differential Clock Input	
29	Even_ClkIN+	Even channel Differential Clock Input	
30	Test Loop (only to pin 1)	Diag. pin for test	
31	Test Loop (only to pin 50)	Diag. pin for test	
32	VDD	Power Supply (+3.3V)	
33	VDD	Power Supply (+3.3V)	



# Product Specification

AU OPTRONICS CORPORATION

34	TEST (BIST_EN)	BIST Function	
35	+5V_ALW	Power Supply (+5V)	
36	VSS	Ground	
37	VSS	Ground	
38	PWM_BL	System side PWM input signal for brightness control	
39	VBL-	LED Power Ground	
40	VBL-	LED Power Ground	
41	VBL-	LED Power Ground	
42	VBL-	LED Power Ground	
43	NC	No Connection	
44	VBL+	Backlight Input Voltage	
45	VBL+	Backlight Input Voltage	
46	VBL+	Backlight Input Voltage	
47	VBL+	Backlight Input Voltage	
48	SMB_DATA	SMBus interface for sending brightness information	
49	SMB_CLK	SMBus interface for sending brightness information	
50	Test Loop (only to pin 31)	Diag. pin for test	

Note1: Start from right side

## 6.4 Interface Timing

### 6.4.1 Timing Characteristics

Basically, interface timings should match the 1440x900 /60Hz manufacturing guide line timing.

Parameter	Symbol	Min.	Typ.	Max.	Unit	
Frame Rate	-	50	60	-	Hz	
Clock frequency	$1/T_{\text{Clock}}$	-	48.2	60.2	MHz	
Vertical Section	Period	$T_V$	904	912	2048	$T_{\text{Line}}$
	Active	$T_{VD}$	900	900	900	
	Blanking	$T_{VB}$	4	12	-	
Horizontal Section	Period	$T_H$	760	880	1024	$T_{\text{Clock}}$
	Active	$T_{HD}$	720	720	720	
	Blanking	$T_{HB}$	40	160	-	

Note : DE mode only

### 6.4.2 Timing diagram

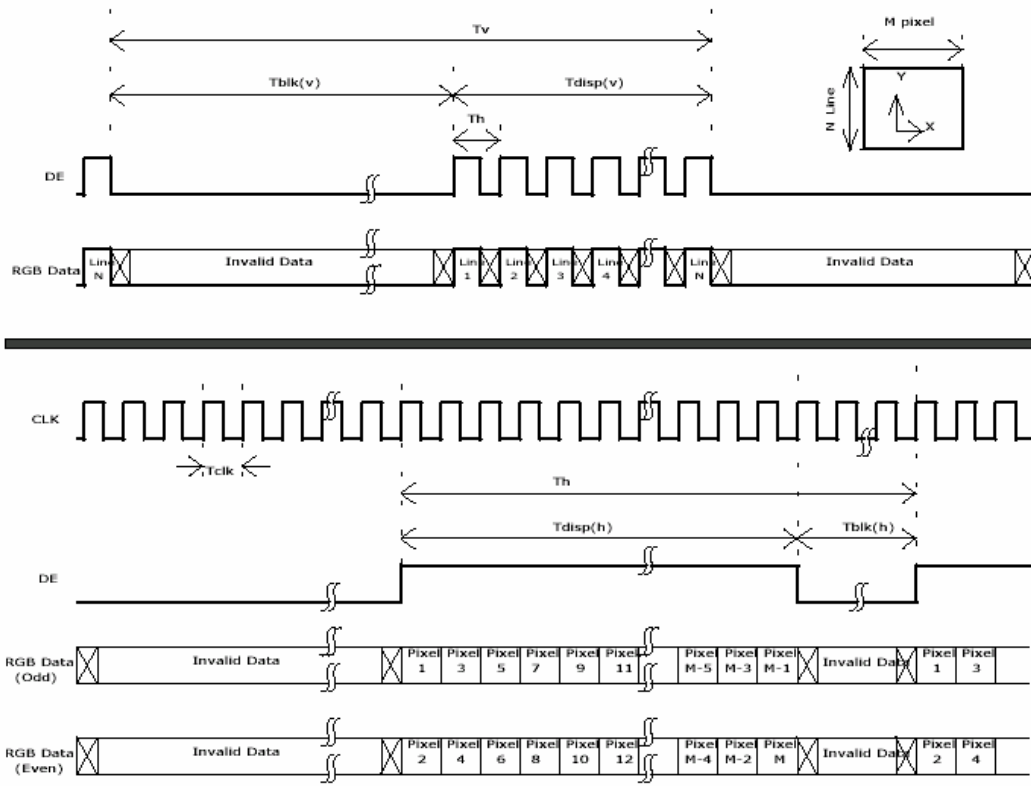

## 6.5 Power ON/OFF Sequence

VDD power and lamp on/off sequence is as follows. Interface signals are also shown in the chart. Signals from any system shall be Hi-Z state or low level when VDD is off.

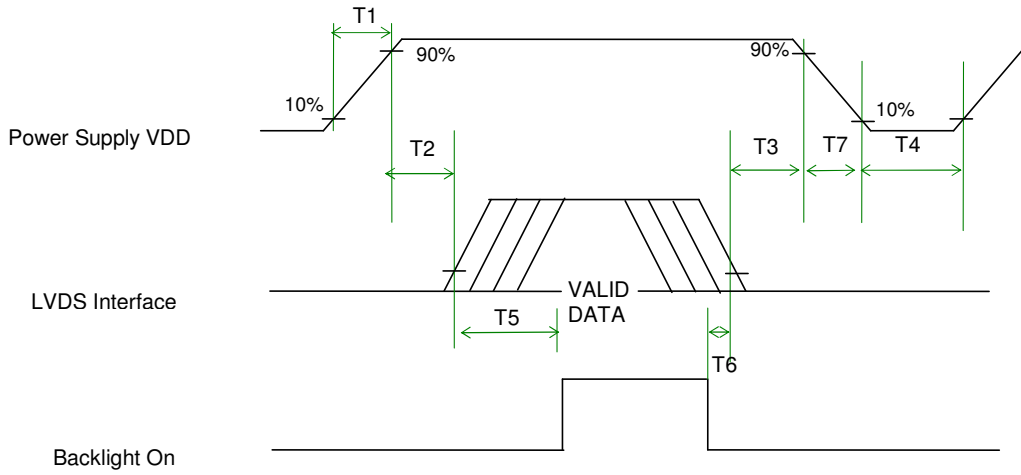

### Power Sequence Timing

Parameter	Value			Units
	Min.	Typ.	Max.	
T1	0.5	-	10	(ms)
T2	5	-	50	(ms)
T3	0.5	-	50	(ms)
T4	400	-	-	(ms)
T5	200	-	-	(ms)
T6	200	-	-	(ms)
T7	0	-	10	(ms)





## 7. Connector Description

Physical interface is described as for the connector on module.

These connectors are capable of accommodating the following signals and will be following components.

### 7.1 TFT LCD Module

<b>Connector Name / Designation</b>	<b>For Signal Connector</b>
Manufacturer	JAE or compatible
Type / Part Number	JAE FI-VHP50S-A-HF11 or compatible
Mating Housing/Part Number	JAE FI-VHP50C-A or compatible

## 8. Dynamic Test

### 8.1 Vibration Test

**Test condition:**

- Acceleration: 1.5 G
- Frequency: 10 - 500Hz Random
- Sweep: 30 Minutes each Axis (X, Y, Z)

### 8.2 Shock Test Spec:

**Test condition:**

- Acceleration: 220 G , Half sine wave
- Active time: 2 ms
- Pulse: +/-X,+/-Y,+/-Z , one time for each side

**Remark:**

1. Ambient condition is  $25 \pm 5^{\circ}\text{C}$ , Relative humidity : 40% ~ 70%
2. Non-packaged and Non-operation

## 9. Reliability

Items	Required Condition	Note
Temperature Humidity Bias	Ta= 40°C, 95%RH, 300h	
High Temperature Operation	Ta= 50°C, Dry, 300h	
Low Temperature Operation	Ta= 0°C, 300h	
High Temperature Storage	Ta= 65°C, 35%RH, 300h	
Low Temperature Storage	Ta= -25°C, 50%RH, 300h	
Thermal Shock Test	Ta=-40°C to 65°C, Duration at 30 min, 100 cycles	
ESD	Contact : ±8 KV Air : ±15 KV	Note 1

**Note1:** According to EN 61000-4-2 , ESD class B: Some performance degradation allowed. No data lost  
 . Self-recoverable. No hardware failures.

**Remark:** MTBF (Excluding the LED): 30,000 hours with a confidence level 90%

## 10. Mechanical Characteristics

### 10.1 LCM Outline Dimension

註解 [BY1]:  
Get from RD-Must paste the PDF format.

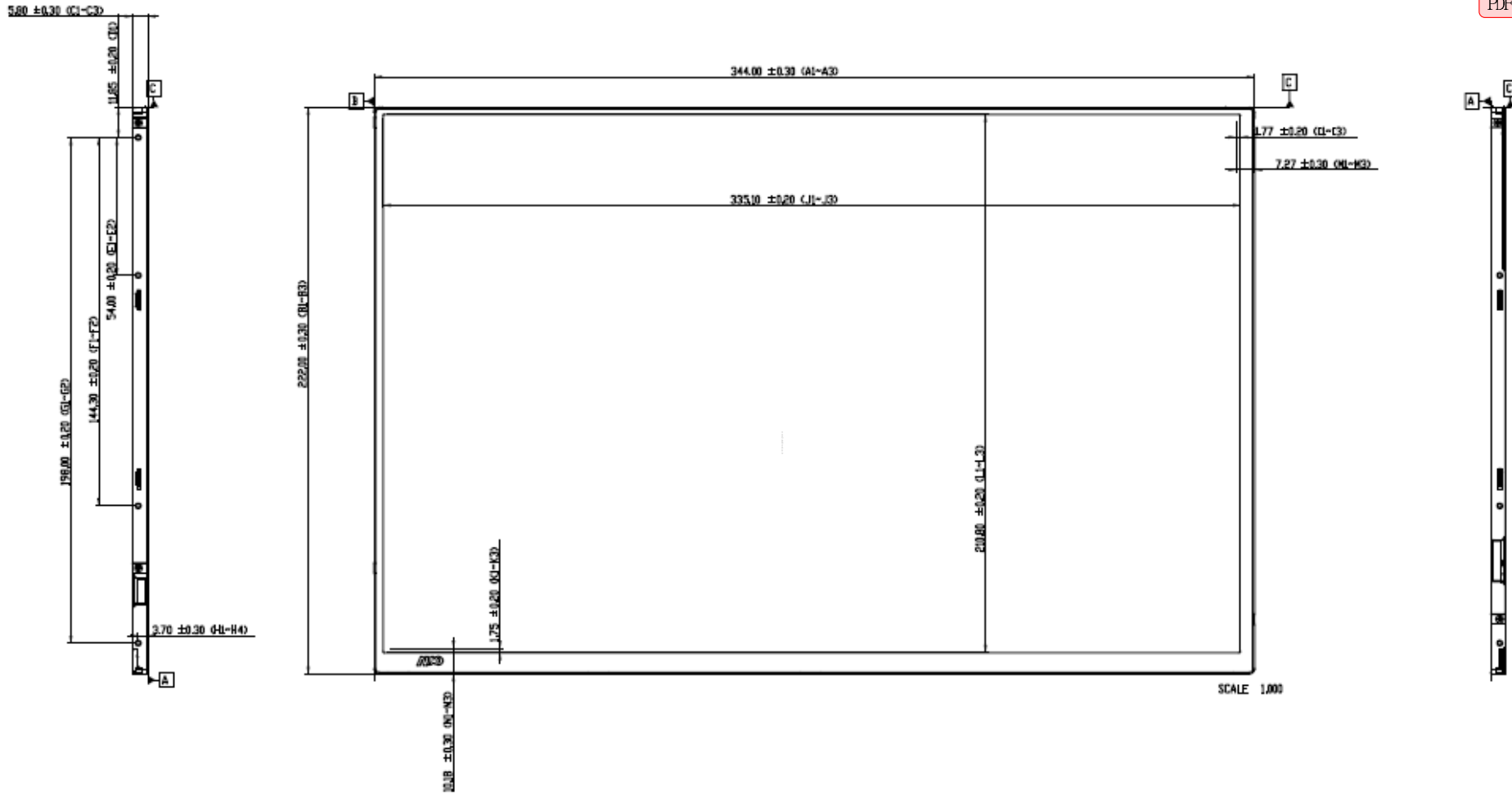

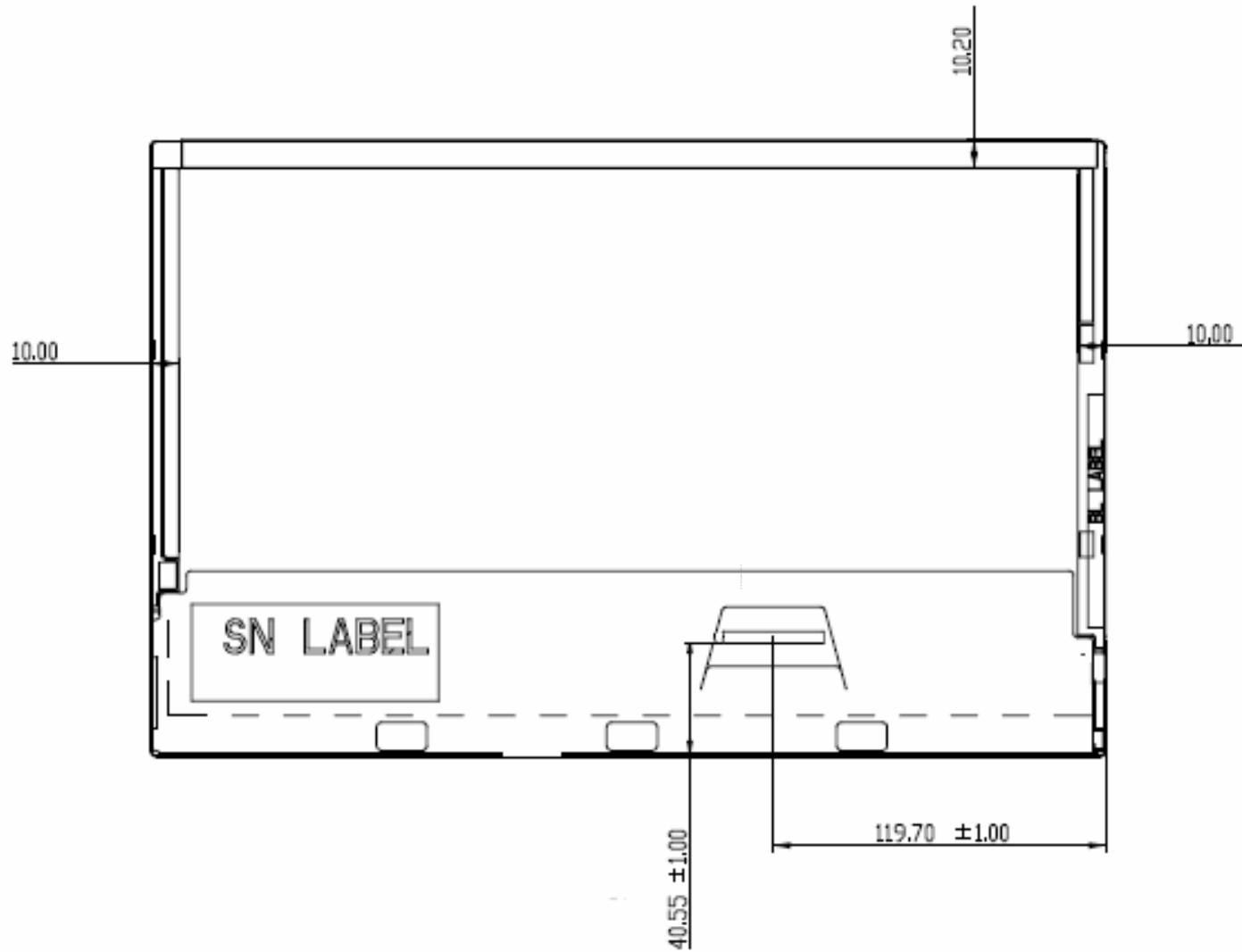

**10.2 Screw Hole Depth and Center Position**

Screw hole minimum depth, from side surface = 2.3 mm (Ref. drawing)

Screw hole center location, from front surface =  $3.7 \pm 0.2$ mm (Ref. drawing)

Screw Torque: Maximum 2.5 kgf-cm

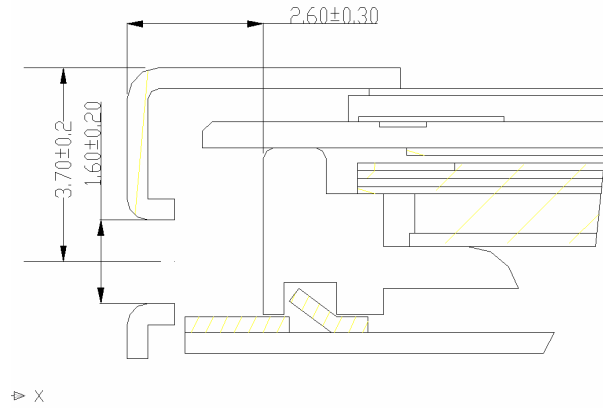

## 11. Shipping and Package

### 11.1 Shipping Label Format



### 11.2 Definition of customer PPID Label and Revision Code

Please refer to the Dell Part identification Label Specification, Number:13190

Sub System Test (SST) Working Sample (WS) ENG 2	X00, X01, X02, ..., X0n
Product Test (PT) Engineering Sample (ES) ENG 3	X10, X11, X12, ..., X1n
System Test (ST) Customer Sample (CS) ENG 4	X20, X21, X22, ... X2n
X-Build (XB) Mass Production (MP) ENG 5	A00, A01, A02, ... A0n

### 11.3 Carton package

The outside dimension of carton is 455 (L)mm x 380 (W)mm x 355 (H)mm

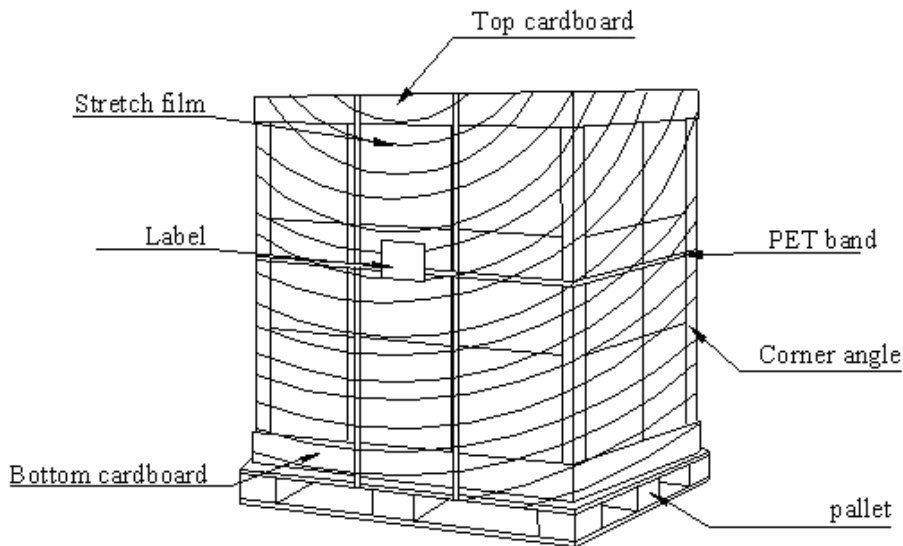
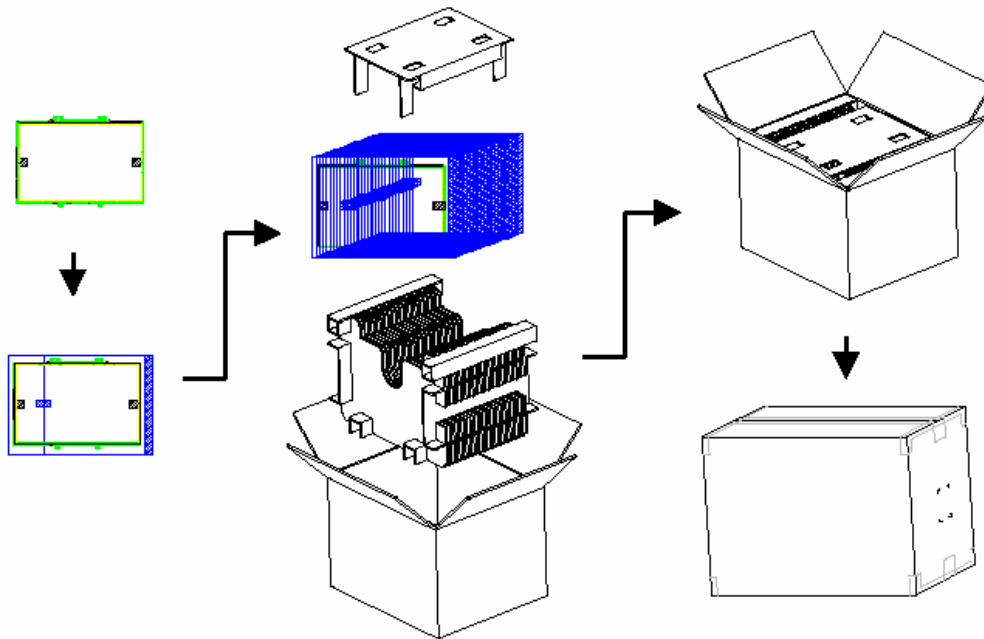



## 12. Appendix: EDID description

Byte (hex)	Field Name and Comments	Value (hex)	Value (binary)	V (I)
0	Header	00	00000000	
1	Header	FF	11111111	
2	Header	FF	11111111	
3	Header	FF	11111111	
4	Header	FF	11111111	
5	Header	FF	11111111	
6	Header	FF	11111111	
7	Header	00	00000000	
8	EISA manufacture code = 3 Character ID	06	00000110	
9	EISA manufacture code (Compressed ASCII)	AF	10101111	
0A	Panel Supplier Reserved – Product Code	77	01110111	
0B	Panel Supplier Reserved – Product Code	43	01000011	
0C	LCD module Serial No - Preferred but Optional (“0” if not used)	00	00000000	
0D	LCD module Serial No - Preferred but Optional (“0” if not used)	00	00000000	
0E	LCD module Serial No - Preferred but Optional (“0” if not used)	00	00000000	
0F	LCD module Serial No - Preferred but Optional (“0” if not used)	00	00000000	
10	Week of manufacture	01	00000001	
11	Year of manufacture	11	00010001	
12	EDID structure version # = 1	01	00000001	
13	EDID revision # = 3	03	00000011	
14	Video I/P definition = Digital I/P (80h)	90	10010000	
15	Max H image size = (Rounded to cm)	21	00100001	
16	Max V image size = (Rounded to cm)	15	00010101	
17	Display gamma = (gamma ×100)-100 = Example: ( 2.2×100 ) – 100 = 120	78	01111000	
18	Feature support ( no DPMS, Active off, RGB, timing BLK 1)	0A	00001010	
19	Red/Green Low bit (RxRy/GxGy)	90	10010000	
1A	Blue/White Low bit (BxBY/WxWy)	B5	10110101	
1B	Red X Rx = 0.6	99	10011001	
1C	Red Y Ry = 0.345	58	01011000	
1D	Green X Gx = 0.32	52	01010010	
1E	Green Y Gy = 0.555	8E	10001110	
1F	Blue X Bx = 0.15	26	00100110	
20	Blue Y By = 0.12	1E	00011110	
21	White X Wx = 0.313	50	01010000	
22	White Y Wy = 0.329	54	01010100	



# Product Specification

AU OPTRONICS CORPORATION

23	Established timings 1 (00h if not used)	00	00000000	
24	Established timings 2 (00h if not used)	00	00000000	
25	Manufacturer's timings (00h if not used)	00	00000000	
26	Standard timing ID1 (01h if not used)	01	00000001	
27	Standard timing ID1 (01h if not used)	01	00000001	
28	Standard timing ID2 (01h if not used)	01	00000001	
29	Standard timing ID2 (01h if not used)	01	00000001	
2A	Standard timing ID3 (01h if not used)	01	00000001	
2B	Standard timing ID3 (01h if not used)	01	00000001	
2C	Standard timing ID4 (01h if not used)	01	00000001	
2D	Standard timing ID4 (01h if not used)	01	00000001	
2E	Standard timing ID5 (01h if not used)	01	00000001	
2F	Standard timing ID5 (01h if not used)	01	00000001	
30	Standard timing ID6 (01h if not used)	01	00000001	
31	Standard timing ID6 (01h if not used)	01	00000001	
32	Standard timing ID7 (01h if not used)	01	00000001	
33	Standard timing ID7 (01h if not used)	01	00000001	
34	Standard timing ID8 (01h if not used)	01	00000001	
35	Standard timing ID8 (01h if not used)	01	00000001	
36	Pixel Clock/10,000 = 96310000 /10000 (LSB)	32	00110010	
37	Pixel Clock/10,000 = 96310000 /10000 (MSB)	2A	00101010	
38	Horizontal Active = 1440 pixels (lower 8 bits)	A0	10100000	
39	Horizontal Blanking (Thbp) = 320 pixels (lower 8 bits)	16	00010110	
3A	Horizontal Active/Horizontal blanking (Thbp) (upper4:4 bits)	52	01010010	
3B	Vertical Active = 900 lines	84	10000100	
3C	Vertical Blanking (Tvbp) = 12 lines (DE Blanking typ. for DE only panels)	0C	00001100	
3D	Vertical Active : Vertical Blanking (Tvbp) (upper4:4 bits)	30	00110000	
3E	Horizontal Sync, Offset (Thfp) = 64 pixels	40	01000000	
3F	Horizontal Sync, Pulse Width = 32 pixels	20	00100000	
40	Vertical Sync, Offset (Tvfp) = 3 lines Sync Width = 3 lines	33	00110011	
41	Horizontal Vertical Sync Offset/Width upper 2 bits	00	00000000	
42	Horizontal Image Size = 331.2 mm	4B	01001011	
43	Vertical image Size = 207 mm	CF	11001111	
44	Horizontal Image Size / Vertical image size	10	00010000	
45	Horizontal Border = 0 (Zero for Notebook LCD)	00	00000000	
46	Vertical Border = 0 (Zero for Notebook LCD)	00	00000000	
47	if display uses standard blanking (HSyncPolarity = POS, VSyncPolarity = NEG) , for DVD compliance.	1A	00011010	



# Product Specification

AU OPTRONICS CORPORATION

48	Pixel Clock/10,000 = 96310000 /10000 (LSB)	32	00110010	
49	Pixel Clock/10,000 = 96310000 /10000 (MSB)	2A	00101010	
4A	Horizontal Active = 1440 pixels (lower 8 bits)	A0	10100000	
4B	Horizontal Blanking (Thbp) = 320 pixels (lower 8 bits)	16	00010110	
4C	Horizontal Active/Horizontal blanking (Thbp) (upper4:4 bits)	52	01010010	
4D	Vertical Active = 900 lines	84	10000100	
4E	Vertical Blanking (Tvbp) = 12 lines (DE Blanking typ. for DE only panels)	0C	00001100	
4F	Vertical Active : Vertical Blanking (Tvbp) (upper4:4 bits)	30	00110000	
50	Horizontal Sync, Offset (Thfp) = 64 pixels	40	01000000	
51	Horizontal Sync, Pulse Width = 32 pixels	20	00100000	
52	Vertical Sync, Offset (Tvfp) = 3 lines Sync Width = 3 lines	33	00110011	
53	Horizontal Vertical Sync Offset/Width upper 2 bits	00	00000000	
54	Horizontal Image Size = 331.2 mm	4B	01001011	
55	Vertical image Size = 207 mm	CF	11001111	
56	Horizontal Image Size / Vertical image size	10	00010000	
57	Horizontal Border = 0 (Zero for Notebook LCD)	00	00000000	
58	Vertical Border = 0 (Zero for Notebook LCD)	00	00000000	
59	if display uses standard blanking (HSyncPolarity = POS, VSyncPolarity = NEG) , for DVD compliance.	1A	00011010	
5A	Flag	00	00000000	
5B	Flag	00	00000000	
5C	Flag	00	00000000	
5D	Dummy Descriptor	FE	11111110	
5E	Flag	00	00000000	
5F	Dell P/N 1 <sup>st</sup> Character	48	01001000	
60	Dell P/N 2 <sup>nd</sup> Character	57	01010111	
61	Dell P/N 3 <sup>rd</sup> Character	36	00110110	
62	Dell P/N 4 <sup>th</sup> Character	36	00110110	
63	Dell P/N 5 <sup>th</sup> Character	33	00110011	
64	EEDID Revision = A00 (X Build and MP)	80	10000000	
65	Manufacturer P/N	42	01000010	
66	Manufacturer P/N	31	00110001	
67	Manufacturer P/N	35	00110101	
68	Manufacturer P/N	34	00110100	
69	Manufacturer P/N	50	01010000	
6A	Manufacturer P/N	57	01010111	
6B	Manufacturer P/N (If <13 char, then terminate with ASCII code 0Ah, set remaining char = 20h)	34	00110100	
6C	Flag	00	00000000	



# Product Specification

AU OPTRONICS CORPORATION

6D	Flag	00	00000000	
6E	Flag	00	00000000	
6F	Data Type Tag:	00	00000000	
70	Flag	00	00000000	
71	SMBUS Value = XX nits	00	00000000	
72	SMBUS Value = XX nits	00	00000000	
73	SMBUS Value = XX nits	00	00000000	
74	SMBUS Value = XX nits	00	00000000	
75	SMBUS Value = XX nits	00	00000000	
76	SMBUS Value = XXX nits	00	00000000	
77	SMBUS Value = XXX nits	00	00000000	
78	SMBUS Value = max nits (Typically = 00h, XXX nits)	00	00000000	
79	Bit[1:0] 00: reserved, 01: single LVDS, 10: dual LVDS, 11: reserved Bit[2] 0: No RTC support, 1: RTC support Bit[7:3] Reserved	02	00000010	
7A	Bit[0] 0: No BIST support, 1: BIST support Bit[7:1] Reserved	01	00000001	
7B	(If <13 char, then terminate with ASCII code 0Ah, set remaining char = 20h)	0A	00001010	
7C	(If <13 char, then terminate with ASCII code 0Ah, set remaining char = 20h)	20	00100000	
7D	(If <13 char, then terminate with ASCII code 0Ah, set remaining char = 20h)	20	00100000	
7E	Extension flag (# of optional 128 EDID extension blocks to follow, Typ = 0)	00	00000000	
7F	Checksum (The 1-byte sum of all 128 bytes in this EDID block shall = 0)	75	01110101	