

AU OPTRONICS CORPORATION

Product Specification

17.0” WXGA+ Color TFT-LCD Module

Model Name: B170PW03 V4

Approved by	Prepared by
<i>Joselyn Liu</i>	<i>Maxine Lee</i>

MDBU Marketing Division / AU Optronics corporation

Customer	Checked & Approved by

Product Specification

17.0" WXGA+ Color TFT-LCD Module **Model Name: B170PW03** **V.4**

(V) Preliminary Specifications
() Final Specifications

Note: This Specification is subject to change without notice.

Contents

1. Handling Precautions	5
2. General Description	6
2.1 Display Characteristics.....	6
2.2 Optical Characteristics	7
3. Functional Block Diagram.....	11
4. Absolute Maximum Ratings	12
4.1 Absolute Ratings of TFT LCD Module	12
4.2 Absolute Ratings of Backlight Unit	12
4.3 Absolute Ratings of Environment	12
5. Electrical characteristics.....	13
5.1 TFT LCD Module	13
5.2 Backlight Unit	15
6. Signal Characteristic	16
6.1 Pixel Format Image	16
6.2 The input data format	17
6.3 Signal Description	18
6.4 Interface Timing.....	20
7. Connector Description	22
7.1 TFT LCD Module	22
7.2 Backlight Unit	22
7.3 Signal for Lamp connector	22
8. Vibration and Shock Test.....	23
8.1 Vibration Test.....	23
8.2 Shock Test Spec:	23
9. Reliability	24
10. Mechanical Characteristics.....	25
10.1 LCM Outline Dimension	25
10.2 ScrPW Hole Depth and Center Position	27
11. Shipping and Package.....	28
11.1 Shipping Label Format	28
11.2. Carton package	29
11.3 Shipping package of palletizing sequence	29
12. Appendix: EDID description.....	30

Record of Revision

Version and Date	Page	Old description	NPW Description	Remark
V1 2005/5/23	All	First Edition for Customer		
V2 2006/10/5	6	Weight: 700g max	Weight 690 max	

1. Handling Precautions

- 1) Since front polarizer is easily damaged, pay attention not to scratch it.
- 2) Be sure to turn off power supply when inserting or disconnecting from input connector.
- 3) Wipe off water drop immediately. Long contact with water may cause discoloration or spots.
- 4) When the panel surface is soiled, wipe it with absorbent cotton or other soft cloth.
- 5) Since the panel is made of glass, it may break or crack if dropped or bumped on hard surface.
- 6) Since CMOS LSI is used in this module, take care of static electricity and insure human earth when handling.
- 7) Do not open nor modify the Module Assembly.
- 8) Do not press the reflector sheet at the back of the module to any directions.
- 9) In case if a Module has to be put back into the packing container slot after once it was taken out from the container, do not press the center of the CCFL Reflector edge. Instead, press at the far ends of the CFL Reflector edge softly. Otherwise the TFT Module may be damaged.
- 10) At the insertion or removal of the Signal Interface Connector, be sure not to rotate nor tilt the Interface Connector of the TFT Module.
- 11) After installation of the TFT Module into an enclosure (Notebook PC Bezel, for example), do not twist nor bend the TFT Module even momentary. At designing the enclosure, it should be taken into consideration that no bending/twisting forces are applied to the TFT Module from outside. Otherwise the TFT Module may be damaged.
- 12) Cold cathode fluorescent lamp in LCD contains a small amount of mercury. Please follow local ordinances or regulations for disposal.
- 13) Small amount of materials having no flammability grade is used in the LCD module. The LCD module should be supplied by power complied with requirements of Limited Power Source(, IEC60950 or UL1950), or be applied exemption.
- 14) The LCD module is designed so that the CFL in it is supplied by Limited Current Circuit(IEC60950 or UL1950). Do not connect the CFL in Hazardous Voltage Circuit.

2. General Description

B170PW03 V4 is a Color Active Matrix Liquid Crystal Display composed of a TFT LCD panel, a driver circuit, and backlight system. The screen format is intended to support the WXGA+ (1440(H) x 900(V)) screen and 262k colors (RGB 6-bits data driver). All input signals are LVDS interface compatible. Inverter of backlight is not included.

B170PW03 V4 is designed for a display unit of notebook style personal computer and industrial machine.

2.1 General Characteristics

The following items are characteristics summary on the table under 25 °C condition:

Items	Unit	Specifications
Screen Diagonal	[mm]	17.0"
Active Area	[mm]	367.20(H) x 229.50(V)
Pixels H x V		1440x3(RGB) x 900
Pixel Pitch	[mm]	0.255(per one triad) x 0.255
Pixel Arrangement		R.G.B. Vertical Stripe
Display Mode		Normally White
White Luminance (ICCFL=6.5mA)	[cd/m ²]	200 typ. (5 points average) 170 min. (5 points average) (Note1)
Luminance Uniformity		1.25 max. (5 points)
Contrast Ratio		300 typ.
Response time	[msec]	16 typ.
Nominal Input Voltage VDD	[Volt]	+3.3 typ.
Typical Power Consumption	[Watt]	8.5 W max.
Weight	[Grams]	690 g max.
Physical Size	[mm]	382.2(W) x 244.5(H) x 6.6(D) max..
Electrical Interface		2 channel LVDS
Surface Treatment		Glare
Support Color		Native 262K colors (RGB 6-bit data driver)
Temperature Range		
Operating	[°C]	0 to +50
Storage (Non-Operating)	[°C]	-20 to +60
RoHS Compliance		RoHS Compliance

2.2 Optical Characteristics

The optical characteristics are measured under stable conditions at 25°C (Room Temperature):

Item	Unit	Conditions	Min.	Typ.	Max.	Note
Luminance ICCFL 6.5mA	[cd/m ²]	5 points average	170	200	-	1,2,3
Viewing Angle	[degree]	Horizontal (Right) CR = 10 (Left)	40	45	-	2,7
	[degree]		40	45	-	
	[degree]	Vertical (Upper) CR = 10 (Lower)	15	20	-	
	[degree]		30	35	-	
Luminance Uniformity		5 Points			1.25	1
Luminance Uniformity		13 Points			2.0	
CR: Contrast Ratio			200	300	-	6
Cross talk	%				4	4
Response Time	[msec]	Rising	-	12	17	5
	[msec]	Falling	-	4	8	
	[msec]	Raising + Falling		16	25	
Color / Chromaticity Coordinates (CIE 1931)		Red x	0.580	0.610	0.640	2,7
		Red y	0.310	0.340	0.370	
		Green x	0.285	0.315	0.345	
		Green y	0.520	0.550	0.580	
		Blue x	0.115	0.145	0.175	
		Blue y	0.085	0.115	0.145	
		White x	0.290	0.320	0.350	
		White y	0.300	0.330	0.360	

Note 1: 5 points position (Display area : 367.20(H) x 229.50(V)mm)

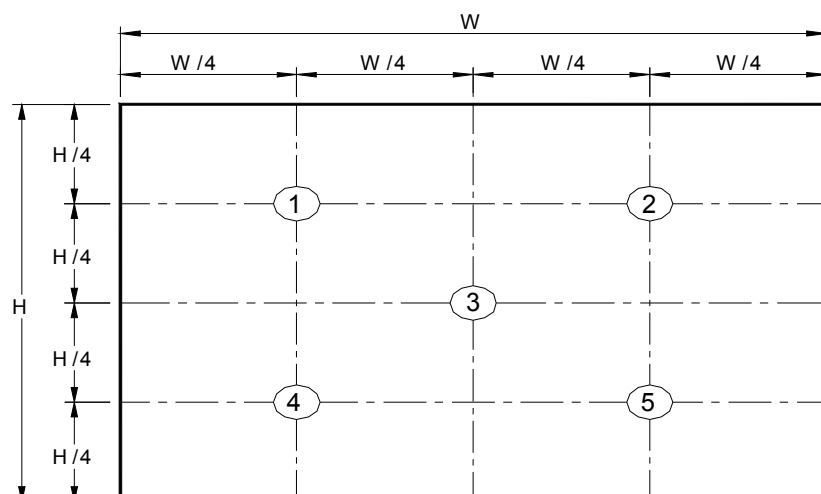

Note 2: 13 points position

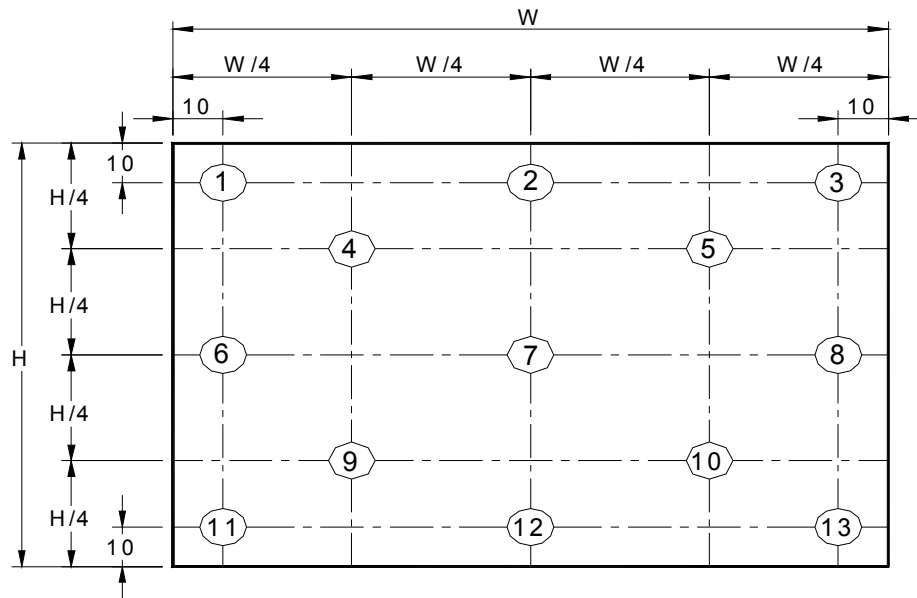

Note 3: The luminance uniformity of 5 and 13 points is defined by dividing the maximum luminance values by the minimum test point luminance

$$\delta_{w5} = \frac{\text{Maximum Brightness of five points}}{\text{Minimum Brightness of five points}}$$

$$\delta_{w13} = \frac{\text{Maximum Brightness of thirteen points}}{\text{Minimum Brightness of thirteen points}}$$

Note 4: Measurement method

The LCD module should be stabilized at given temperature for 30 minutes to avoid abrupt temperature change during measuring. In order to stabilize the luminance, the measurement should be executed after lighting Backlight for 30 minutes in a stable, windless and dark room.

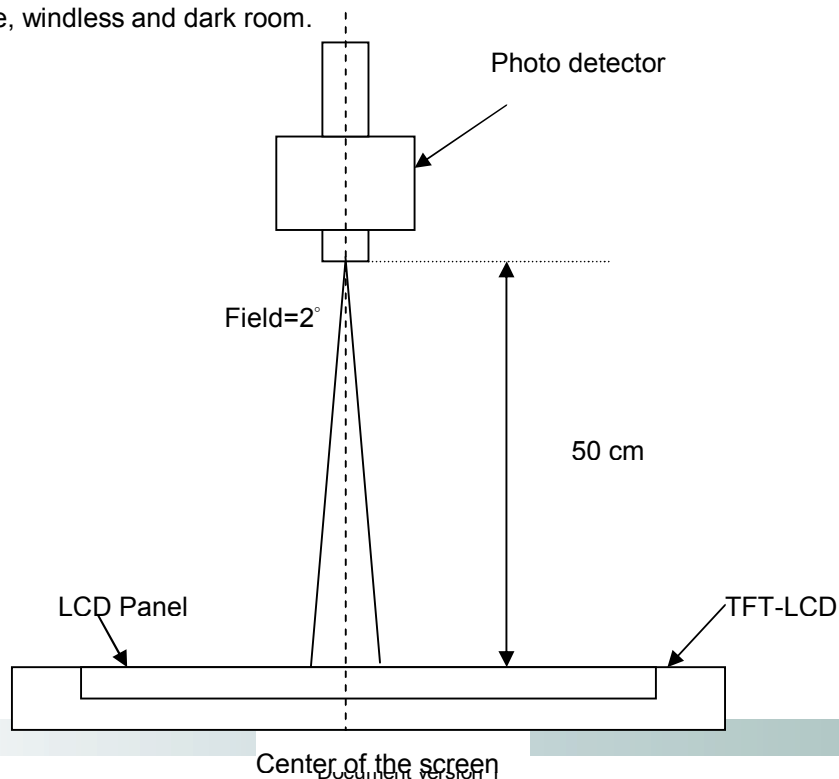

Note 5 : Definition of Cross Talk (CT)

$$CT = |Y_B - Y_A| / Y_A \times 100 (\%)$$

Where

Y_A = Luminance of measured location without gray level 0 pattern (cd/m²)

Y_B = Luminance of measured location with gray level 0 pattern (cd/m²)

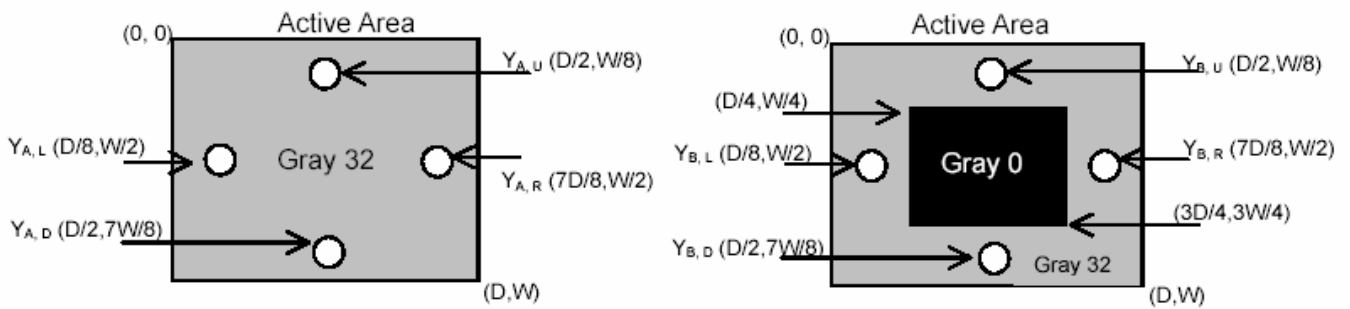

Note 6: Definition of response time:

The output signals of BM-7 or equivalent are measured when the input signals are changed from “Black” to “White” (falling time) and from “White” to “Black” (rising time), respectively. The response time interval between the 10% and 90% of amplitudes. Refer to figure as below.

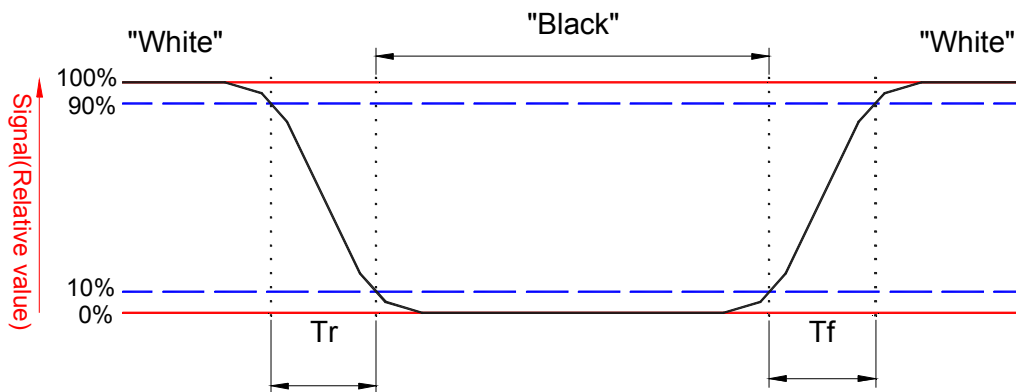

Note 7. Definition of viewing angle

Viewing angle is the measurement of contrast ratio ≥ 10 , at the screen center, over a 180° horizontal and 180° vertical range (off-normal viewing angles). The 180° viewing angle range is broken down as follows; 90° (θ) horizontal left and right and 90° (Φ) vertical, high (up) and low (down). The measurement direction is typically perpendicular to the display surface with the screen rotated about its center to develop the desired measurement viewing angle.

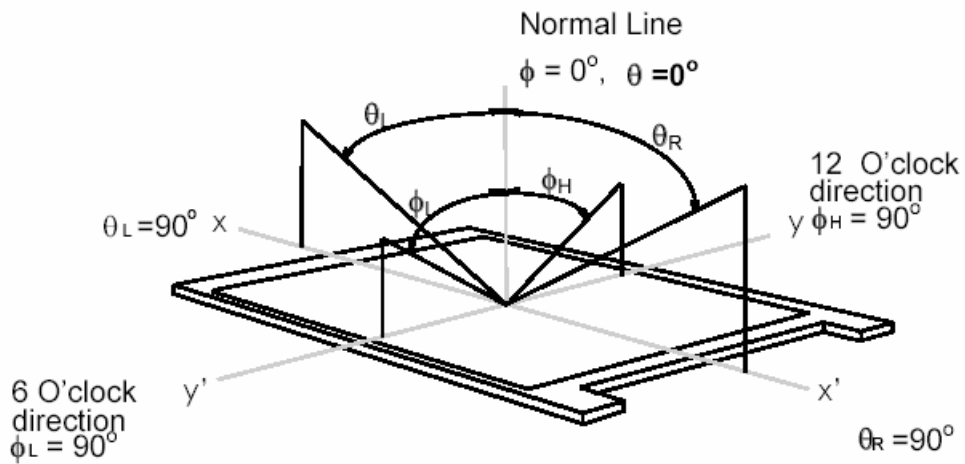

3. Functional Block Diagram

The following diagram shows the functional block of the 17.0 inches wide Color TFT/LCD Module:

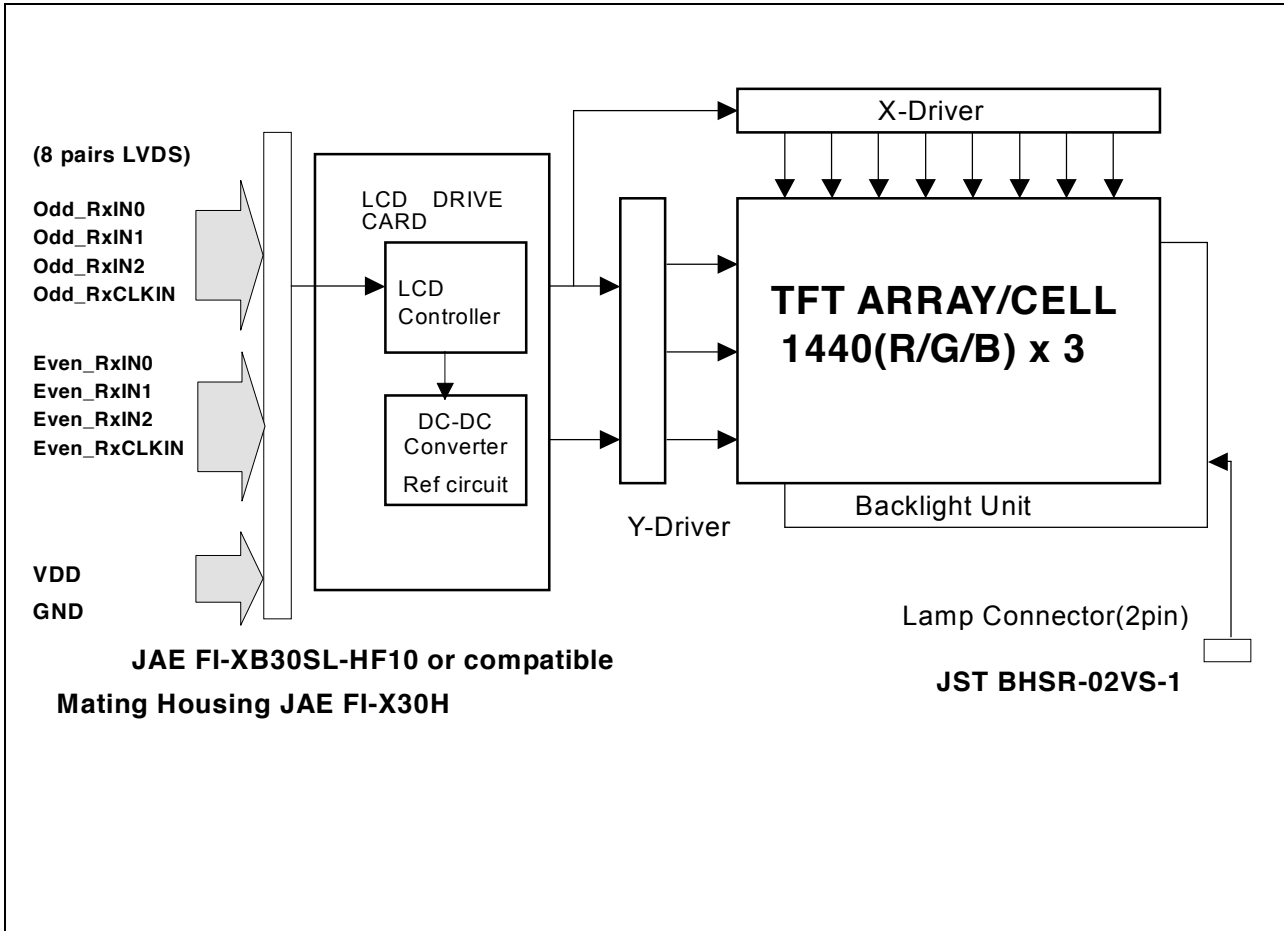

4. Absolute Maximum Ratings

Absolute maximum ratings of the module is as following:

4.1 Absolute Ratings of TFT LCD Module

Item	Symbol	Min	Max	Unit	Conditions
Logic/LCD Drive	Vin	-0.3	+4.0	[Volt]	Note 1,2

4.2 Absolute Ratings of Backlight Unit

Item	Symbol	Min	Max	Unit	Conditions
CCFL Current	ICCFL	-	6.5	[mA] rms	Note 1,2

4.3 Absolute Ratings of Environment

Item	Symbol	Min	Max	Unit	Conditions
Operating Temperature	TOP	0	+50	[°C]	Note 3
Operation Humidity	HOP	5	95	[%RH]	Note 3
Storage Temperature	TST	-20	+60	[°C]	Note 3
Storage Humidity	HST	5	95	[%RH]	Note 3

Note 1: With in Ta (25°C)

Note 2: Permanent damage to the device may occur if exceed maximum values

Note 3: For quality performance, please refer to AUO IIS(Incoming Inspection Standard).

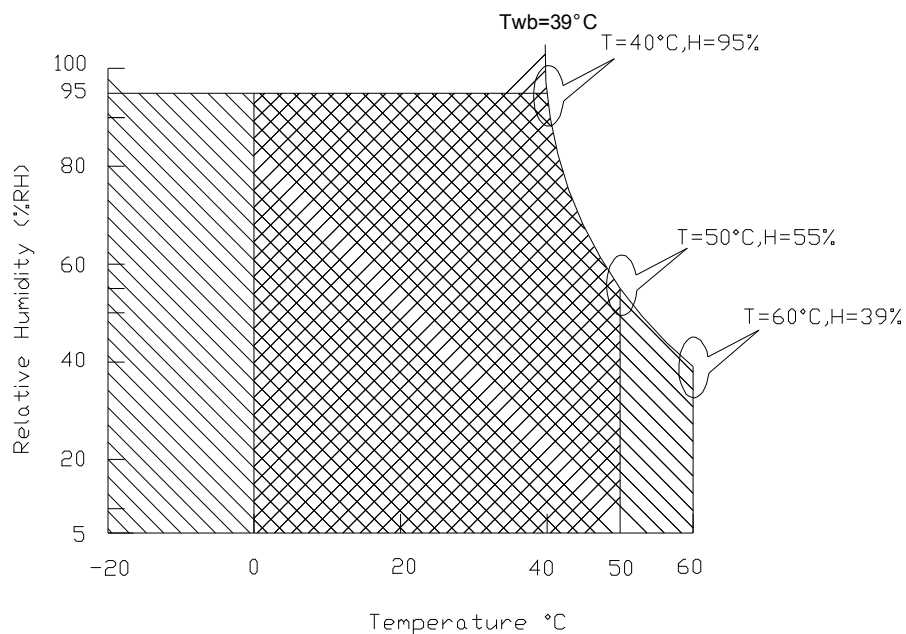

Operating Range



Storage Range



5. Electrical characteristics

5.1 TFT LCD Module

5.1.1 Power Specification

Input power specifications are as follows;

Symble	Parameter	Min	Typ	Max	Units	Condition
VDD	Logic/LCD Drive Voltage	3.0	3.3	3.6	[Volt]	Load Capacitance 20uF
PDD	VDD Power		2.15		[Watt]	All White pattern
IDD	IDD Current		680		mA	Max:All Black Pattern
IRush	Inrush Current			2000	mA	
VDDrp	Allowable Logic/LCD Drive Ripple Voltage			100	[mV] p-p	
VDDns	Allowable Logic/LCD Drive Ripple Noise			100	[mV] p-p	

Note 1 : Measurement conditions:

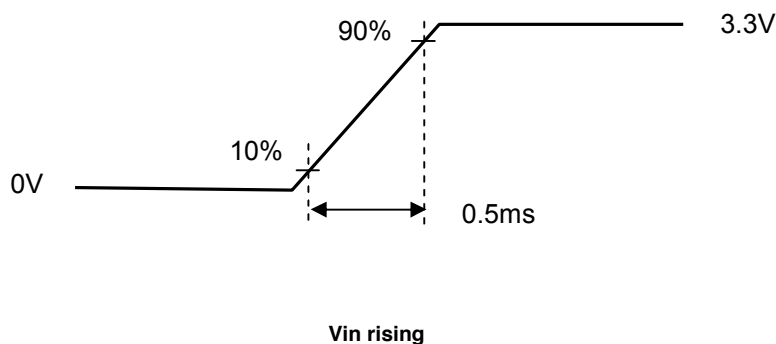
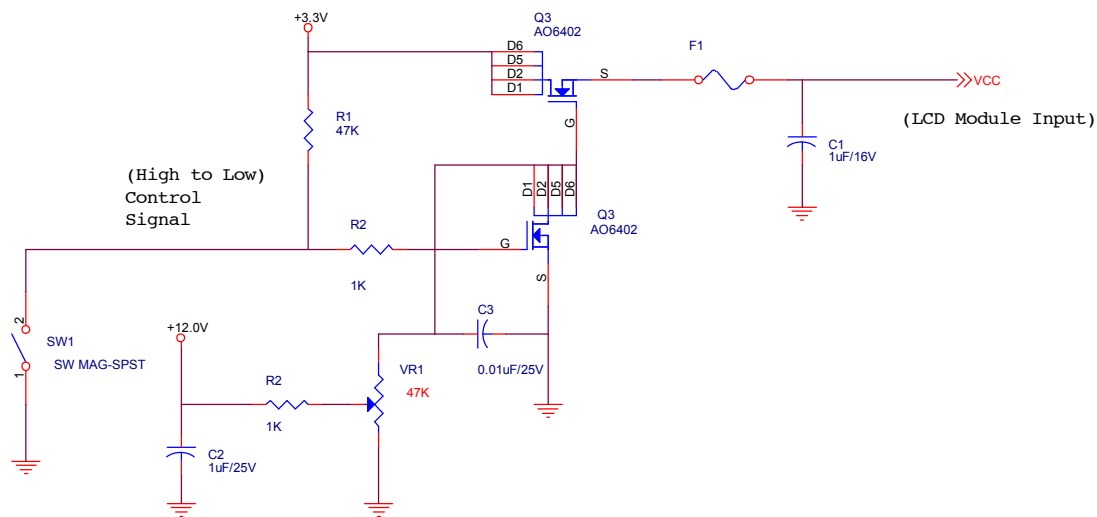

5.1.2 Signal Electrical Characteristics

Input signals shall be low or Hi-Z state when VDD is off.

It is recommended to refer the specifications of THC63LVDF84A(Thine Electronics Inc.) in detail. Signal electrical characteristics are as follows;

Parameter	Condition	Min	Max	Unit
Vth	Differential Input High Threshold (Vcm=+1.2V)		100	[mV]
Vtl	Differential Input Low Threshold (Vcm=+1.2V)	-100		[mV]
Vcm	Differential Input Common Mode Voltage	1.125	1.375	[V]

Note: LVDS Signal Waveform

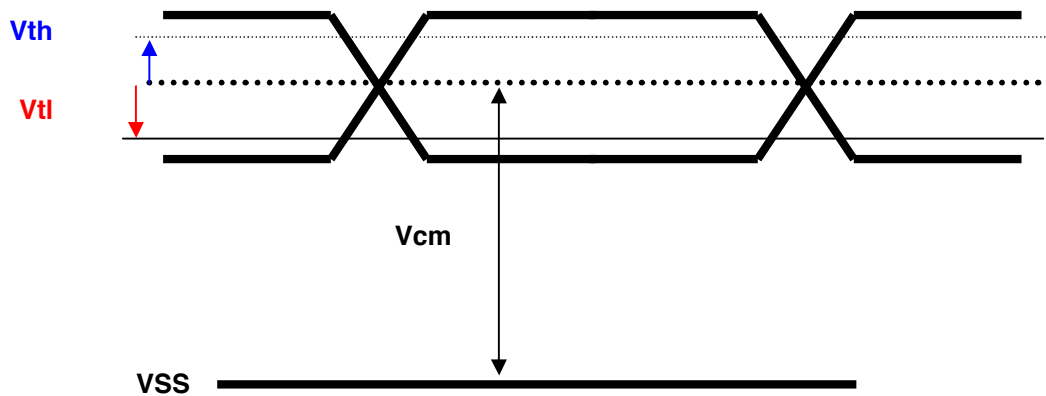

5.2 Backlight Unit

Parameter guideline for CCFL Inverter

Parameter	Min	Typ	Max	Units	Condition
White Luminance 5 points average	170	200	-	[cd/m ²]	(Ta=25°C)
CCFL current(ICCFL)	3.0	6.5	7.0	[mA] rms	(Ta=25°C) Note 2
CCFL Frequency(FCCFL)	45	50	80	[KHz]	(Ta=25°C) Note 3,4
CCFL Ignition Voltage(Vs)	1500			[Volt] rms	(Ta= 0°C) Note 5
CCFL Voltage (Reference) (VCCFL)	775	815	940	[Volt] rms	(Ta=25°C) Note 6
CCFL Power consumption (PCCFL)		4.9		[Watt]	(Ta=25°C) Note 6

Note 1: Typ are AUO recommended Design Points.

*1 All of characteristics listed are measured under the condition using the AUO Test inverter.

*2 In case of using an inverter other than listed, it is recommended to check the inverter carefully. Sometimes, interfering noise stripes appear on the screen, and substandard luminance or flicker at low power may happen.

*3 In designing an inverter, it is suggested to check safety circuit very carefully. Impedance of CFL, for instance, becomes more than 1 [M ohm] when CFL is damaged.

*4 Generally, CFL has some amount of delay time after applying kick-off voltage. It is recommended to keep on applying kick-off voltage for 1 [Sec] until discharge.

*5 CFL discharge frequency must be carefully chosen so as not to produce interfering noise stripes on the screen.

*6 Reducing CFL current increases CFL discharge voltage and generally increases CFL discharge frequency. So all the parameters of an inverter should be carefully designed so as not to produce too much leakage current from high-voltage output of the inverter.

Note 2: It should be employed the inverter which has "Duty Dimming", if ICCFL is less than 4mA.

Note 3: CFL discharge frequency should be carefully determined to avoid interference between inverter and TFT LCD.

Note 4: The frequency range will not affect to lamp life and reliability characteristics.

Note 5: CFL inverter should be able to give out a power that has a generating capacity of over 1,430 voltage. Lamp units need 1,400 voltage minimum for ignition.

Note 6: Calculator value for reference (ICCFL × VCCFL = PCCFL)

6. Signal Characteristic

6.1 Pixel Format Image

Following figure shows the relationship of the input signals and LCD pixel format.

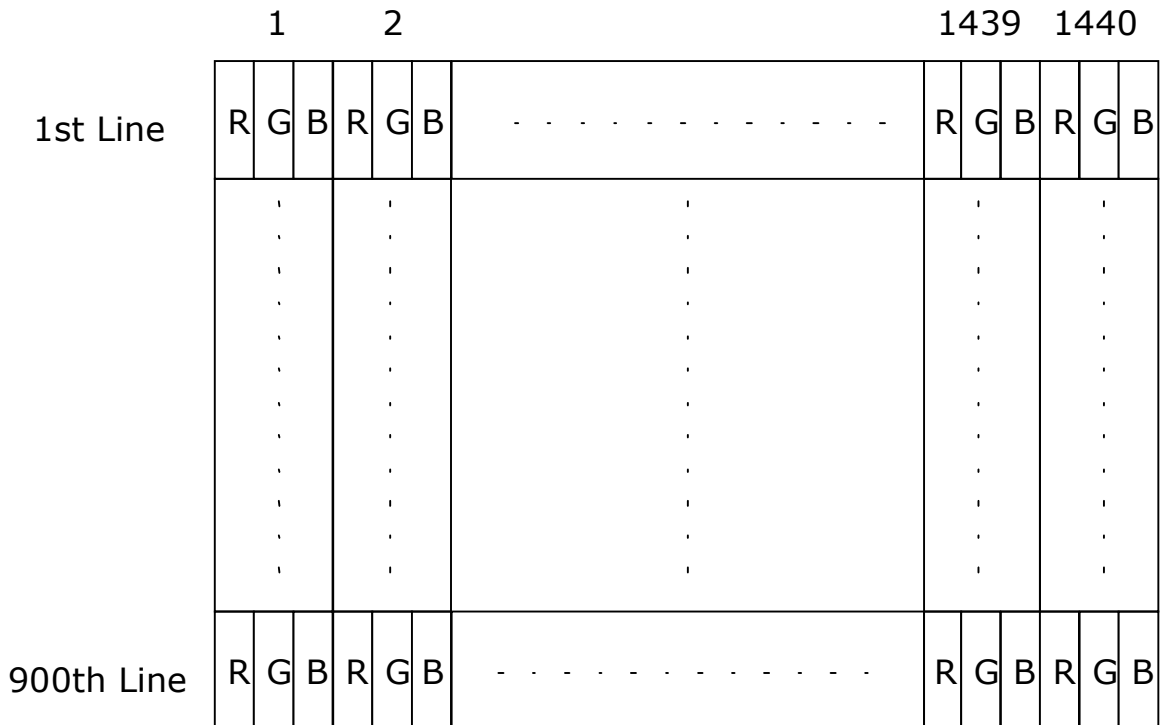

6.2 The input data format

ODD pair(1st pixel input)

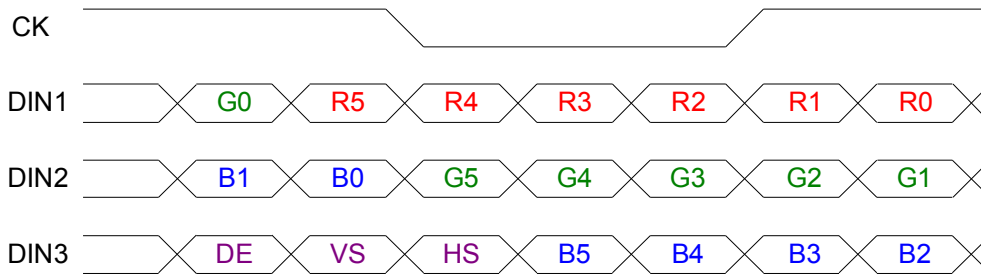

Even pair(2nd pixel input)

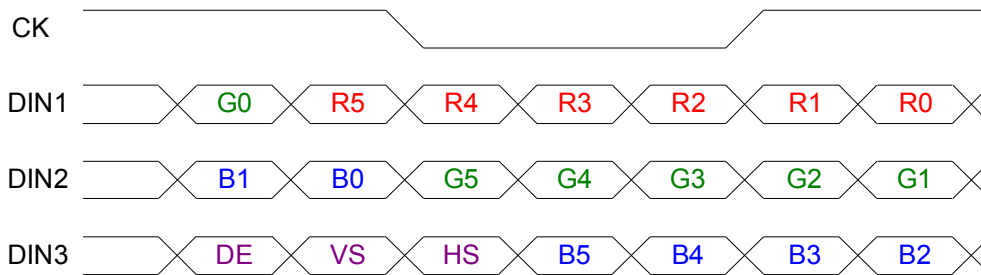

Signal Name	Description	
R5 R4 R3 R2 R1 R0	Red Data 5 (MSB) Red Data 4 Red Data 3 Red Data 2 Red Data 1 Red Data 0 (LSB) Red-pixel Data	Red-pixel Data Each red pixel's brightness data consists of these 6 bits pixel data.
G5 G4 G3 G2 G1 G0	Green Data 5 (MSB) Green Data 4 Green Data 3 Green Data 2 Green Data 1 Green Data 0 (LSB) Green-pixel Data	Green-pixel Data Each green pixel's brightness data consists of these 6 bits pixel data.
B5 B4 B3 B2 B1 B0	Blue Data 5 (MSB) Blue Data 4 Blue Data 3 Blue Data 2 Blue Data 1 Blue Data 0 (LSB) Blue-pixel Data	Blue-pixel Data Each blue pixel's brightness data consists of these 6 bits pixel data.
RxCLKIN	Data Clock	The typical frequency is 48.2 MHz. The signal is used to strobe the pixel data and DSPTMG signals. All pixel data shall be valid at the falling edge when the DSPTMG signal is high.
DE	Display Timing	This signal is strobed at the falling edge of -DTCLK. When the signal is high, the pixel data shall be valid to be displayed.
VS	Vertical Sync	The signal is synchronized to -DTCLK .
HS	Horizontal Sync	The signal is synchronized to -DTCLK .

Note: Output signals from any system shall be low or Hi-Z state when VDD is off.

6.3 Signal Description

LVDS is a differential signal technology for LCD interface and high speed data transfer device.

Pin no	Symbol	Function	Etc.
1	GND	Ground	
2	VDD	Power supply ,3.3 V (typical)	
3	VDD	Power supply ,3.3 V (typical)	
4	V _{EDID}	DDC 3.3V power	
5	NC	No Connection (Reserved for AUO) test	
6	CLK _{EDID}	DDC Clock	
7	Data _{EDID}	DDC data	
8	Odd_RxIN0-	-LVDS differential data input	
9	Odd_RxIN0+	+LVDS differential data input	
10	GND	Ground	
11	Odd_RxIN1-	-LVDS differential data input	
12	Odd_RxIN1+	+LVDS differential data input	
13	GND	Ground	
14	Odd_RxIN2-	-LVDS differential data input	
15	Odd_RxIN2+	+LVDS differential data input	
16	GND	Ground	
17	Odd_RxCLKIN-	-LVDS differential clock input	
18	Odd_RxCLKIN+	+LVDS differential clock input	
19	GND	Ground	
20	Even_RxIN0-	-LVDS differential data input	
21	Even_RxIN0+	+LVDS differential data input	
22	GND	Ground	
23	Even_RxIN1-	-LVDS differential data input	
24	Even_RxIN1+	+LVDS differential data input	
25	GND	Ground	
26	Even_RxIN2-	-LVDS differential data input	
27	Even_RxIN2+	+LVDS differential data input	
28	GND	Ground	
29	Even_RxCLKIN-	-LVDS differential clock input	
30	Even_RxCLKIN+	+LVDS differential clock input	

Product Specification

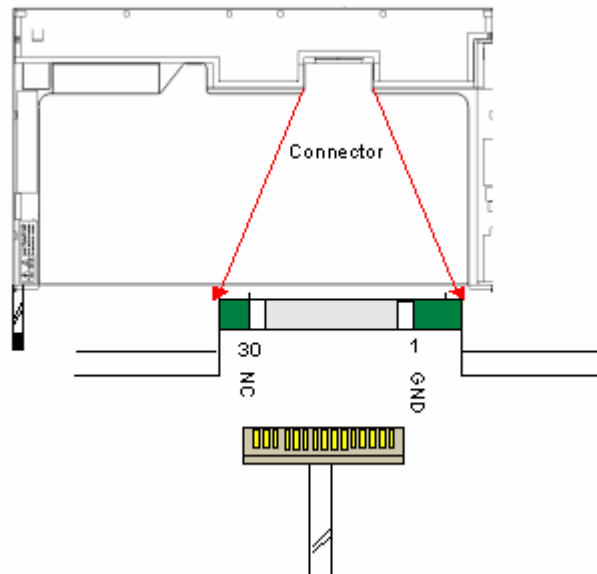

Note1: Start from right side

Note2: Please follow VESA standard.

Note3: Input signals shall be low or High-impedance when VDD is off.

Internal circuit of LVDS inputs are as following.

The module uses a 100ohm resistor between positive and negative data lines of each receiver input

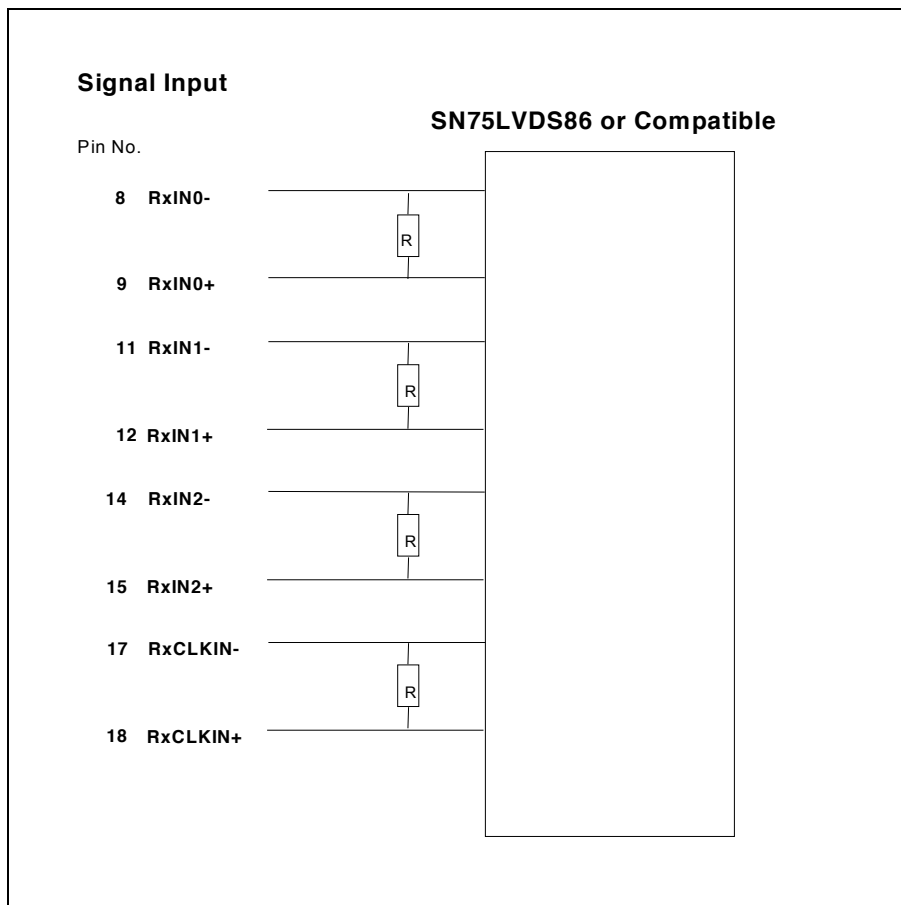

6.4 Interface Timing

6.4.1 Timing Characteristics

Basically, interface timings should match the 1440x900 /60Hz manufacturing guide line timing.

Parameter	Symbol	Min.	Typ.	Max.	Unit	Condition	
Clock frequency	$1/T_{\text{CLOCK}}$	20	48.2	85	MHz	LVDS 2 channel input	
Horizontal Section	Period	T_H	840	880	1024	T_{CLOCK}	
	Active	T_{HD}	720	720	720		
	Blanking	T_{HB}	140	160	304		
	Hsync Width	T_{HSW}	10	16	20		
	Back Porch	T_{HSB}	98	112	142		
	Front Porch	T_{HSF}	142	32	142		
Vertical Section	Period	T_V	911	912	2048	T_{HD}	
	Active	T_{VD}	900	900	900		
	Blanking	T_{VB}	11	12	1148		
	Vsync Width	T_{VSW}	2	3	5		
	Back Porch	T_{VSB}	6	6	1140		
	Front Porch	T_{VSF}	3	3	3		

Note : DE mode only

6.4.2 Timing diagram

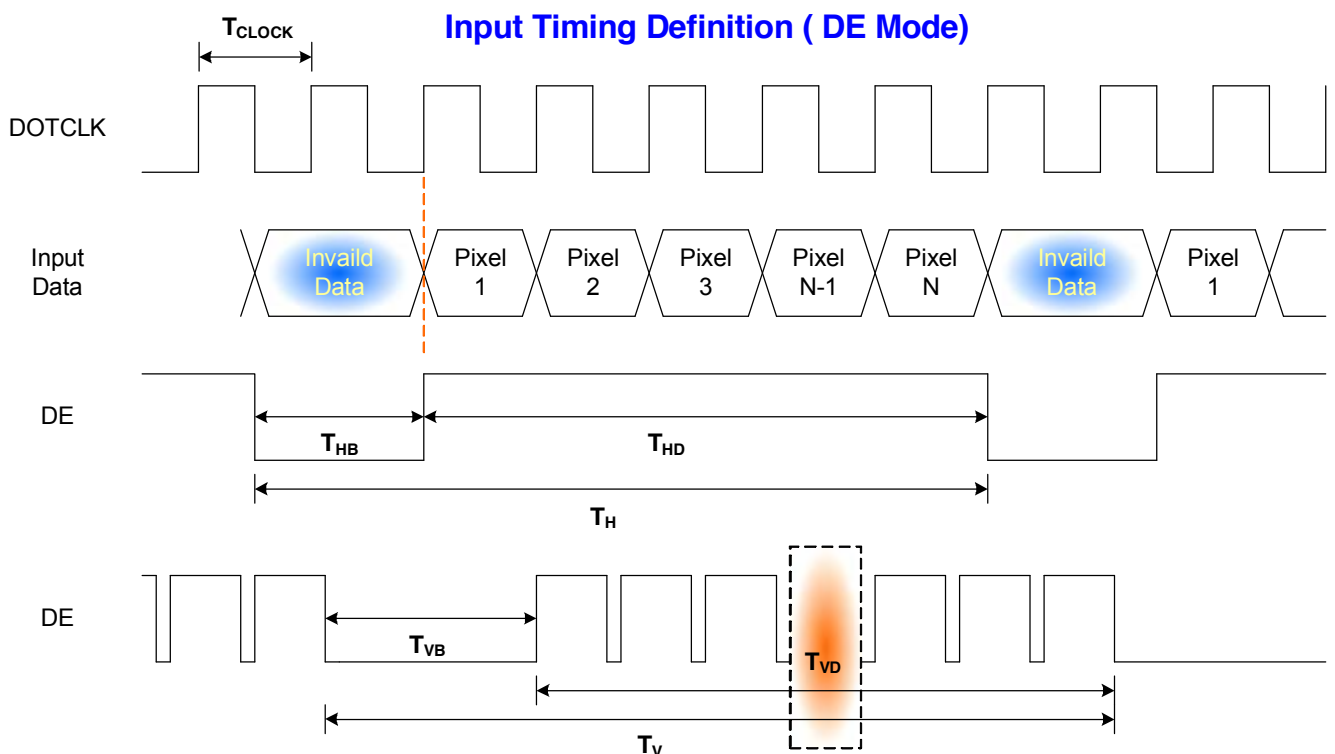

6.5 Power ON/OFF Sequence

VDD power and lamp on/off sequence is as follows. Interface signals are also shown in the chart. Signals from any system shall be Hi-Z state or low level when VDD is off.

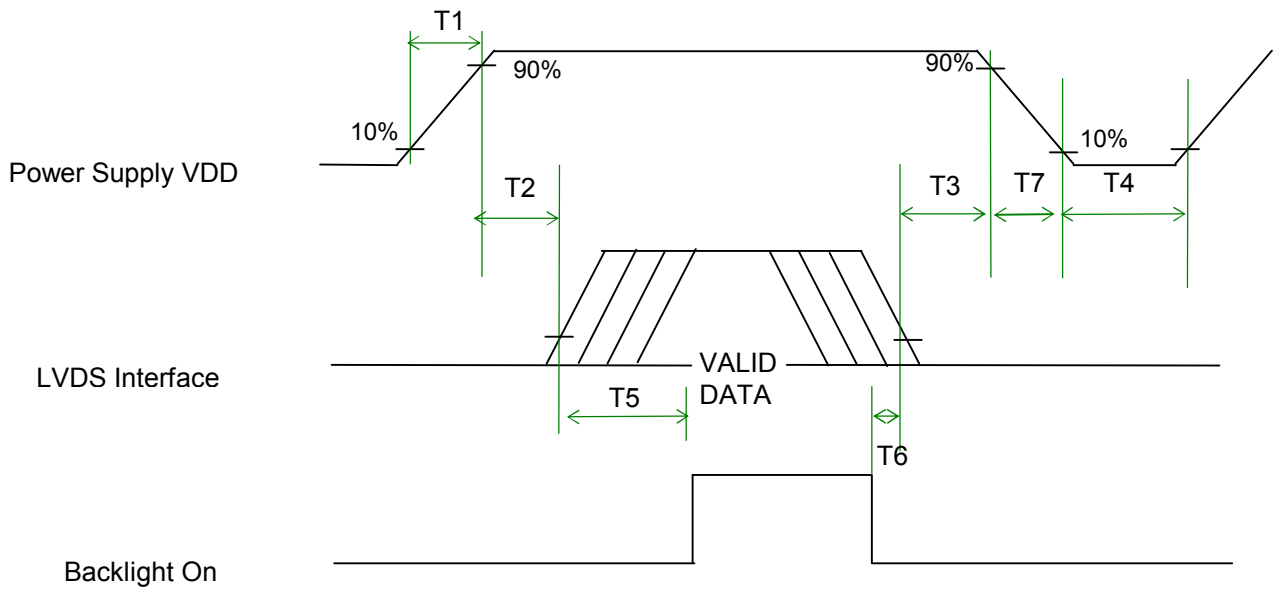

Power Sequence

Parameter	Value			Units
	Min.	Typ.	Max.	
T1	0.5	-	10	(ms)
T2	0	-	50	(ms)
T3	0	-	50	(ms)
T4	400	-	-	(ms)
T5	200	-	-	(ms)
T6	200	-	-	(ms)
T7	0	-	10	(ms)

Timing

7. Connector Description

Physical interface is described as for the connector on module.

These connectors are capable of accommodating the following signals and will be following components.

7.1 TFT LCD Module

Connector Name / Designation	For Signal Connector
Manufacturer	JAE or compatible
Type / Part Number	FI-XB30SL-HF10 or compatible
Mating Housing/Part Number	FI-X30H
Mating Contact/Part Number	FI-XC3-1-15000

7.2 Backlight Unit

Physical interface is described as for the connector on module.

These connectors are capable of accommodating the following signals and will be following components.

Connector Name / Designation	For Lamp Connector
Manufacturer	JST
Type / Part Number	BHSR-02VS-1
Mating Type / Part Number	SM02B-BHSS-1-TB

7.3 Signal for Lamp connector

Pin #	Cable color	Signal Name
1	Red	Lamp High Voltage
2	White	Lamp Low Voltage

8. Vibration and Shock Test

8.1 Vibration Test

Test Spec:

Test method:	Non-Operation
Acceleration:	1.5G
Frequency:	10 - 500Hz Random
Sweep:	30 Minutes each Axis (X, Y, Z)

8.2 Shock Test Spec:

Test Spec:

Test method:	Non-Operation
Acceleration:	180 G , Half sine wave
Active time:	2 ms
Pulse:	X,Y,Z .one time for each side

9. Reliability

Items	Required Condition	Note
Temperature Humidity Bias	40°C/95%,300Hr	
High Temperature Operation	60°C/Dry,300Hr	
Low Temperature Operation	0°C,300Hr	
On/Off Test	25°C,150hrs(ON/10 sec. OFF/10sec., 10,000 cycles)	
Hot Storage	60°C/35% RH ,250 hours	
Cold Storage	-20°C/50% RH ,250 hours	
Thermal Shock Test	-20°C/30 min ,60°C/30 min 100cycles	
Hot Start Test	50°C/1 Hr min. power on/off per 5 minutes, 5 times	
Cold Start Test	0°C/1 Hr min. power on/off per 5 minutes, 5 times	
Shock Test (Non-Operating)	180G, 2ms, Half-sine wave	
Vibration Test (Non-Operating)	Random vibration, 1.5 G zero-to-peak, 10 to 500 Hz, 30 mins in each of three mutually perpendicular axes.	
ESD	Contact : ±8KV/ operation Air : ±15KV / operation	Note 1
Room temperature Test	25°C, 2000hours, Operating with loop pattern	

Note1: According to EN61000-4-2 , ESD class B: Some performance degradation allowed. No data lost

. Self-recoverable. No hardware failures.

Note2: CCFL Life time: 10,000 hours minimum under normal module usage.

Note3: MTBF (Excluding the CCFL): 30,000 hours with a confidence level 90%

10. Mechanical Characteristics

10.1 LCM Outline Dimension(Front View)

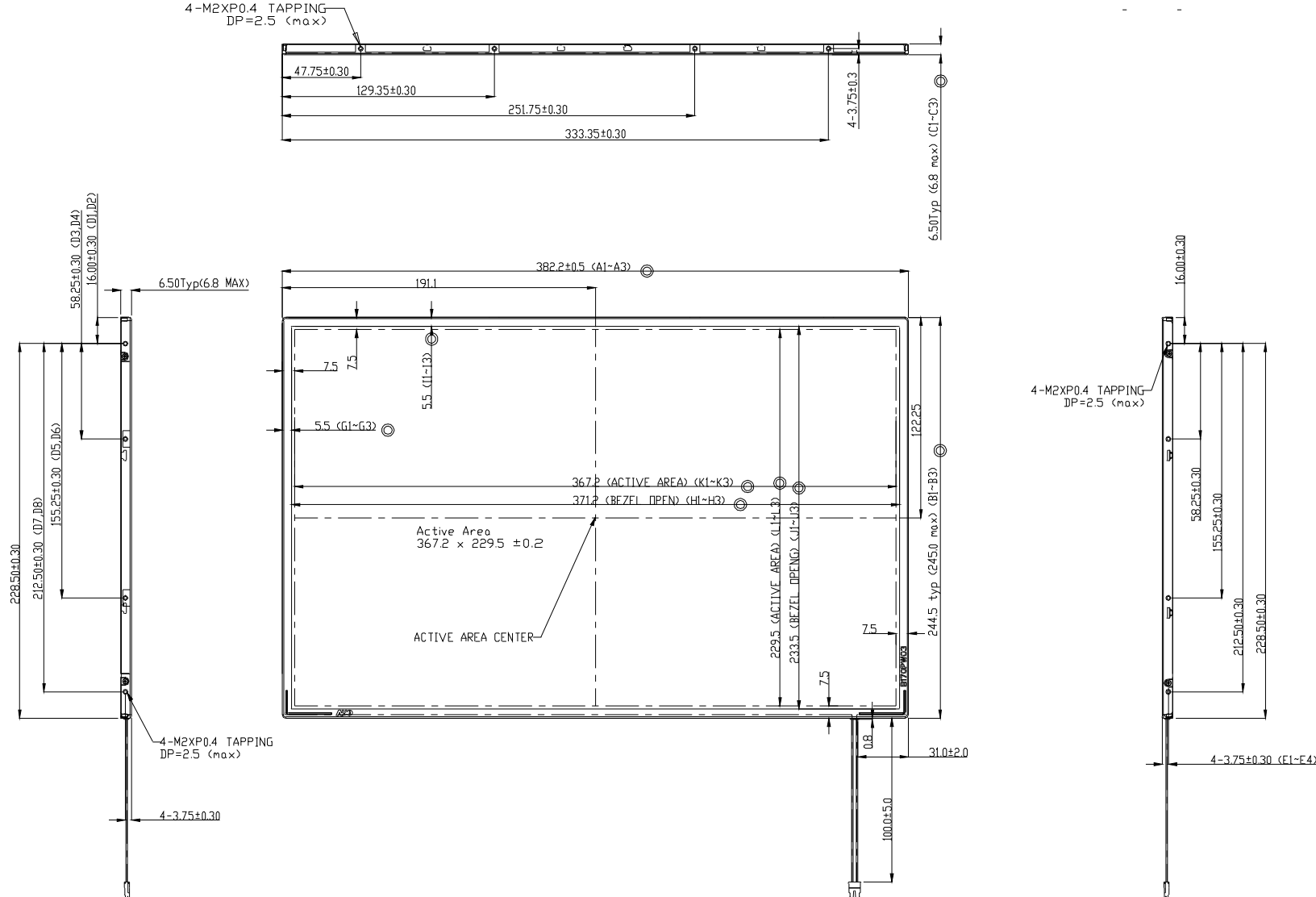

10.2 LCM Outline Dimension(Rear View)

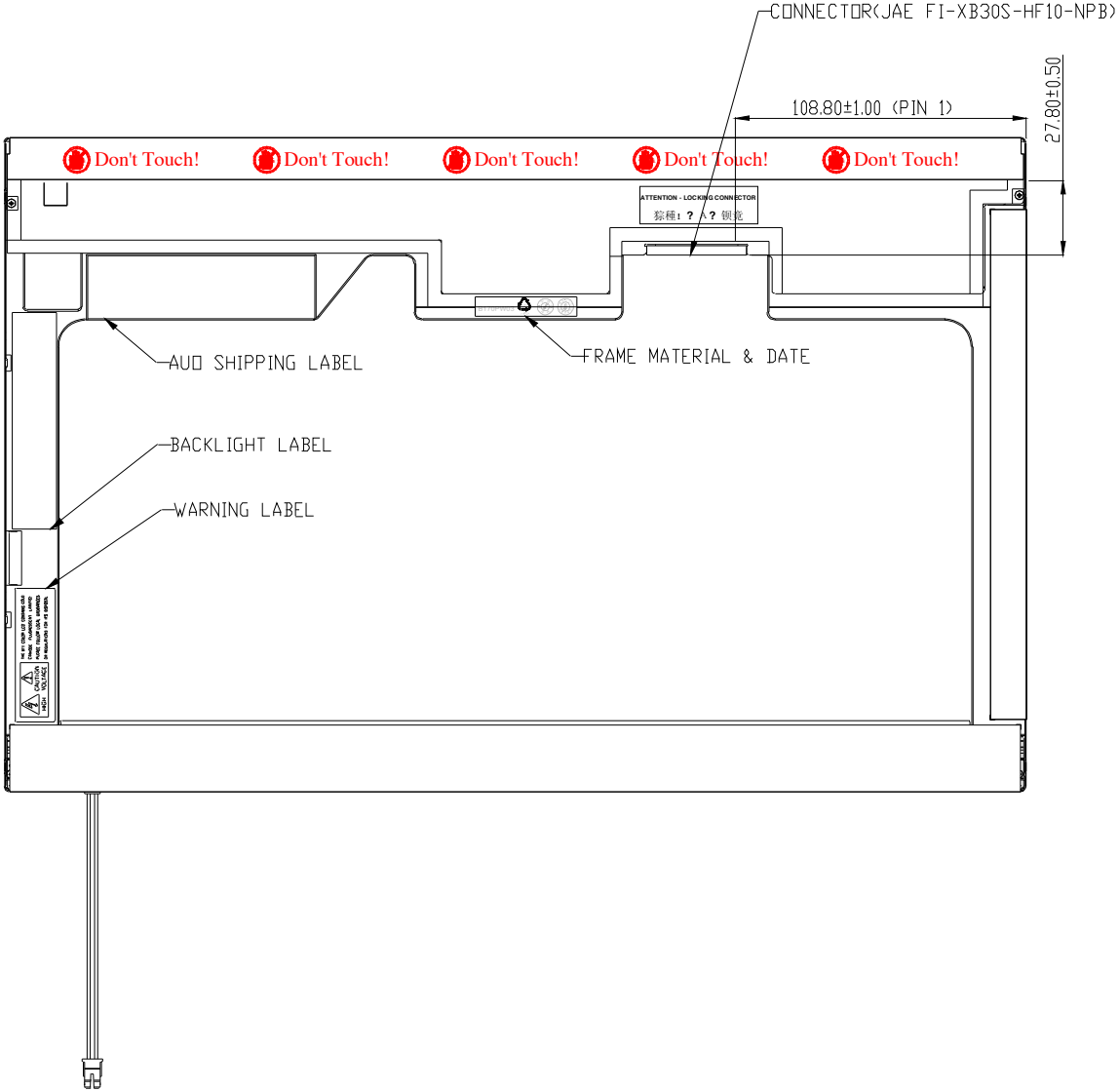

10.3 Screw Hole Depth and Center Position

Screw hole minimum depth, from side surface = 2.6 mm (See drawing)

Screw hole center location, from front surface = 3.75 ± 0.2 mm (See drawing)

Screw maximum length = 2.3 mm (See drawing)

Screw Torque: Maximum 2.5 kgzf-cm

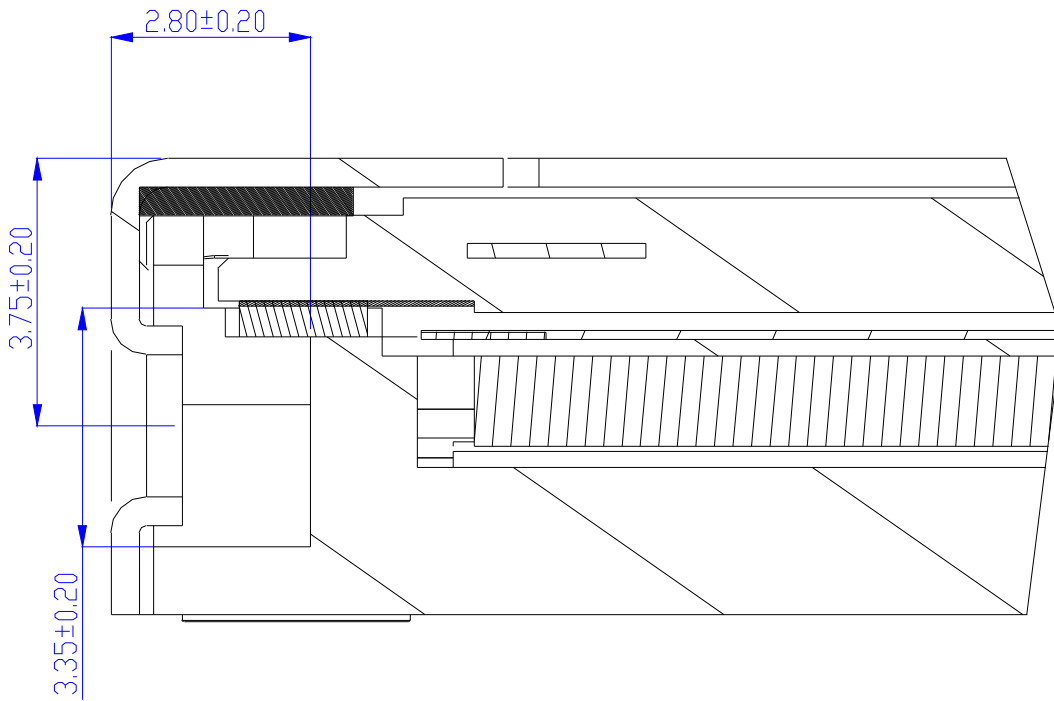

11. Shipping and Package

11.1 Shipping Label Format

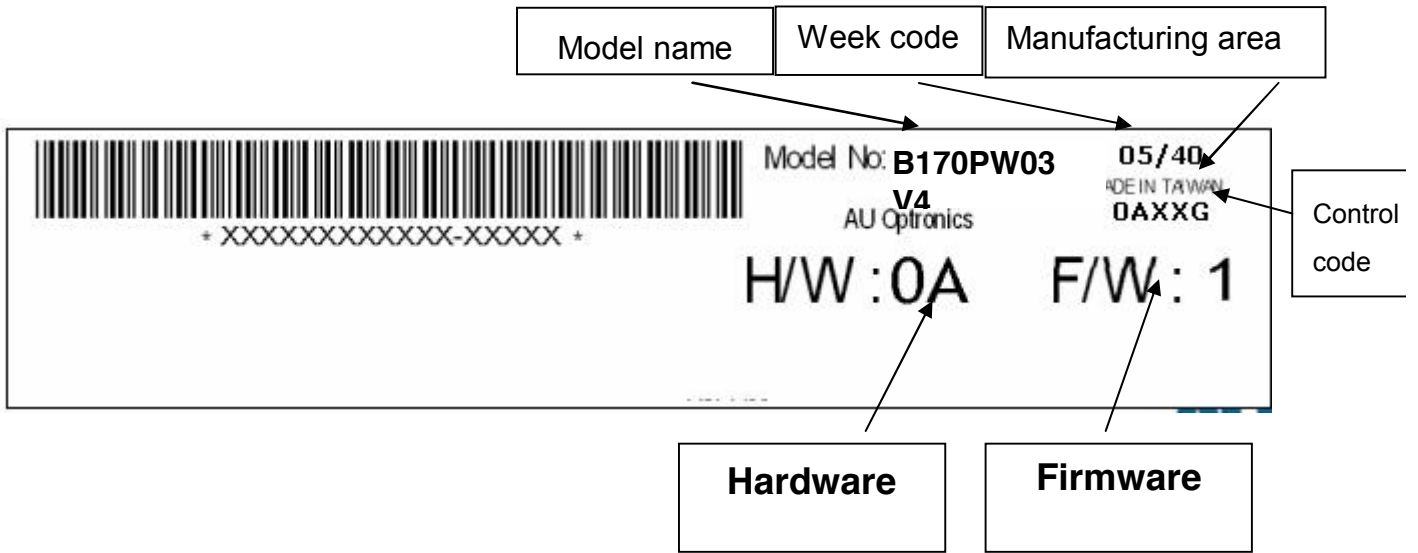

11.2. Carton package

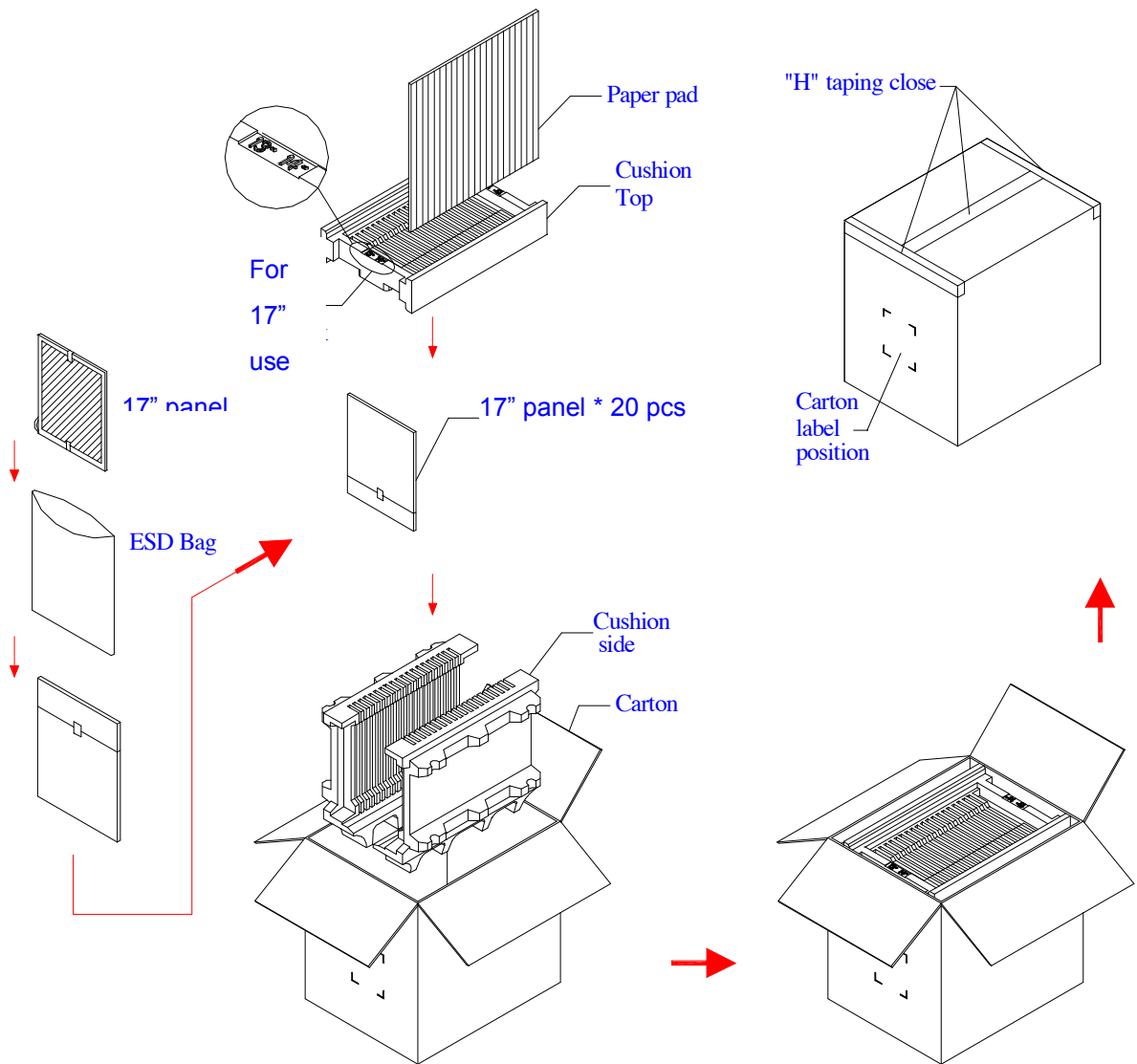

12. Appendix: EDID description

TBD