



Product Specification

G190EG02 V0

AU OPTRONICS CORPORATION

() Preliminary Specification

(V) Final Specification

Module	19.0" SXGA Color TFT-LCD
Model Name	G190EG02 V0

Customer	Date
_____	_____
Approved by	
_____	_____
<p>Note: This Specification is subject to change without notice.</p>	

Checked & Approved by	Date
<u>Vito Huang</u>	<u>July 1, 2013</u>
Prepared by	
<u>Ginger Lin</u>	<u>July 1, 2013</u>
<p>Desktop Display Business Group / AU Optronics corporation</p>	

Record of Revision

Version & Date	Page	Old Description	New Description	Remark																
0.1 2010/1/19	All	First Edition for Customer																		
0.2 2010/8/05	12		New Block Function Diagram																	
	28		New Drawing (Front)																	
	29		New Drawing (Rear)																	
0.3 2010/12/10	6		New Physical Size																	
	7,13,16		New LED Current																	
	16		Updated Swing Voltage																	
	22		New Power ON/OFF Sequence																	
	27		New Drawing (Front)																	
	28		New Drawing (Rear)																	
1.0 2011/040/6	27		New Drawing (Front)																	
	28		New Drawing (Rear)																	
1.1 2011/06/20	16	Dimming Frequency:	Dimming Frequency:																	
		<table border="1"> <thead> <tr> <th>Min.</th> <th>Typ.</th> <th>Max.</th> <th>Unit</th> </tr> </thead> <tbody> <tr> <td>18</td> <td>20</td> <td></td> <td>[kHz]</td> </tr> </tbody> </table>	Min.	Typ.	Max.	Unit	18	20		[kHz]	<table border="1"> <thead> <tr> <th>Min.</th> <th>Typ.</th> <th>Max.</th> <th>Unit</th> </tr> </thead> <tbody> <tr> <td>200</td> <td>-</td> <td>20K</td> <td>[Hz]</td> </tr> </tbody> </table>	Min.	Typ.	Max.	Unit	200	-	20K	[Hz]	
		Min.	Typ.	Max.	Unit															
18	20		[kHz]																	
Min.	Typ.	Max.	Unit																	
200	-	20K	[Hz]																	
	28		Indicate connector Pin 1																	
			Remove "Thickness 18 mm Max"																	
1.2 2013/07/01	24		Update 7.1.1 Connector																	
1.2 2013/07/01	25		Update 7.2 Backlight Connector																	
1.2 2013/07/01	25		Update 7.2.1 Pin#7 & #9																	
1.2 2013/07/01	27~29		Add Packing Form																	



Contents

1. Handling Precautions	4
2. General Description	5
2.1 Display Characteristics	6
3. Functional Block Diagram	12
4. Absolute Maximum Ratings	13
4.1 Absolute Ratings of TFT LCD Module	13
4.2 Absolute Ratings of Backlight Unit	13
4.3 Absolute Ratings of Environment	13
5. Electrical characteristics	15
5.1 TFT LCD Module	15
5.2 Backlight Unit.....	16
6. Signal Characteristic	17
6.1 Pixel Format Image	17
6.2 The Input Data Format	18
6.4 Interface Timing.....	21
6.5 Power ON/OFF Sequence.....	23
7. Connector & Pin Assignment	24
7.1 TFT LCD Module	24
7.2 Backlight Unit.....	25
8. Reliability Test	26
9. Shipping Label	27
10. Packing Form	27
11. Mechanical Characteristic	30

1. Handling Precautions

- 1) Since front polarizer is easily damaged, pay attention not to scratch it.
- 2) Be sure to turn off power supply when inserting or disconnecting from input connector.
- 3) Wipe off water drop immediately. Long contact with water may cause discoloration or spots.
- 4) When the panel surface is soiled, wipe it with absorbent cotton or other soft cloth.
- 5) Since the panel is made of glass, it may break or crack if dropped or bumped on hard surface.
- 6) Since CMOS LSI is used in this module, take care of static electricity and insure human earth when handling.
- 7) Do not open or modify the Module Assembly.
- 8) Do not press the reflector sheet at the back of the module to any directions.
- 9) In case if a Module has to be put back into the packing container slot after once it was taken out from the container, do not press the center of the LED reflector edge. Instead, press at the far ends of the LED Reflector edge softly. Otherwise the TFT Module may be damaged.
- 10) At the insertion or removal of the Signal Interface Connector, be sure not to rotate nor tilt the Interface Connector of the TFT Module.
- 11) After installation of the TFT Module into an enclosure, do not twist nor bend the TFT Module even momentary. At designing the enclosure, it should be taken into consideration that no bending/twisting forces are applied to the TFT Module from outside. Otherwise the TFT Module may be damaged.
- 12) Small amount of materials having no flammability grade is used in the LCD module. The LCD module should be supplied by power complied with requirements of Limited Power Source (IEC60950 or UL1950), or be applied exemption.
- 13) The LCD module is designed so that the LED in it is supplied by Limited Current Circuit (IEC60950 or UL1950).



2. General Description

G190EG02 V0 is a Color Active Matrix Liquid Crystal Display composed of a TFT-LCD panel, a driver circuit, and backlight system. The screen format is intended to support the SXGA (1280(H) x 1024(V)) screen and 16.7M colors 8-bits. All input signals are LVDS interface compatible. G190EG02 V0 is designed for a general display unit.



2.1 Display Characteristics

The following items are characteristics summary on the table under 25 °C condition:

Items	Unit	Specifications
Screen Diagonal	[mm]	482.6 (19.0")
Active Area	[mm]	376.32 (H) x 301.056 (V)
Pixels H x V		1280(x3) x 1024
Pixel Pitch	[mm]	0.294 (per one triad) x 0.294
Pixel Arrangement		R.G.B. Vertical Stripe
Display Mode		Normally Black
White Luminance	[cd/m ²]	600 (center, Typ)
Contrast Ratio		2000: 1 (Typ)
Optical ResponseTime	[msec]	8ms GTG (Avg. Typ.); 20 ms(Typ, on/off)
Nominal Input Voltage VDD	[Volt]	+5.0 V
Power Consumption	[Watt]	55 W (Typ)
Weight	[Grams]	2000 (Typ) ; 2100 (Max)
Physical Size (H x V x D)	[mm]	396 (H) x 324 (V) x 21.35 (D) (Typ)
Electrical Interface		Dual channel LVDS
Surface Treatment		Hard-coating (3H), Non-Glare treatment
Support Color		16.7M colors 8-bits
Temperature Range Operating Storage (Non-Operating)	[°C] [°C]	0 to +50 -20 to +60
RoHS Compliance		RoHS Compliance

2.2 Optical Characteristics

The optical characteristics are measured under stable conditions at 25°C (Room Temperature):

Item	Unit	Conditions	Min.	Typ.	Max.	Note
Viewing Angle	[degree]	Horizontal (Right) CR = 10 (Left)	75 75	89 89	-	1
		Vertical (Up) CR = 10 (Down)	75 75	89 89	-	
Luminance Uniformity	[%]	9 Points	75	80	-	2, 3
Response time	[msec]	Rising		15	25	4,6
		Falling		5	15	4,6
		Rising + Falling		20	40	4,6
		Grey to Grey (Avg.)	-	8	16	4,6
Color / Chromaticity Coordinates (CIE 1931)		Red x	0.617	0.647	0.677	4
		Red y	0.31	0.34	0.37	
		Green x	0.277	0.327	0.377	
		Green y	0.571	0.601	0.641	
		Blue x	0.112	0.142	0.172	
		Blue y	0.037	0.067	0.099	
		White x	0.283	0.313	0.34	
White y	0.299	0.329	0.359			
Black Luminance (At LED =100mA)	[cd/m ²]			0.3	0.45	4
White Luminance (At LED =100mA)	[cd/m ²]		450	600	-	4
Contrast Ratio			1000	2000	-	4
Cross Talk (At 75Hz)	[%]		-	-	1.5	5
Flicker	[dB]		-	-	-20	7
C.G.L		$\Delta u'v'$	-	-	0.02	8

Optical Equipment: BM-5A, PR880, SR3, CS1000 or equivalent.

Note 1: Definition of viewing angle

Viewing angle is the measurement of contrast ratio ≥ 10 , at the screen center, over a 180° horizontal and 180° vertical range (off-normal viewing angles). The 180° viewing angle range is broken down as follows; 90° (θ) horizontal left and right and 90° (ϕ) vertical, high (up) and low (down). The measurement direction is typically perpendicular to the display surface with the screen rotated about its center to develop the desired measurement viewing angle.

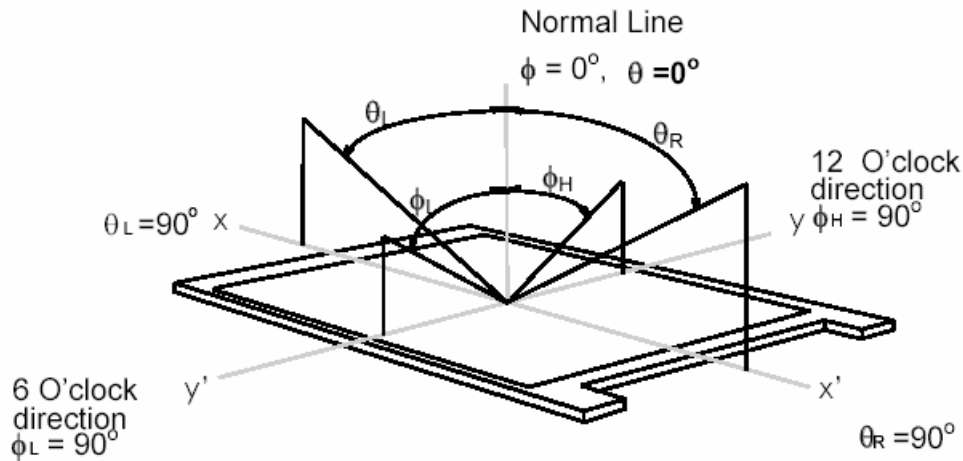

Note 2: 9 points position

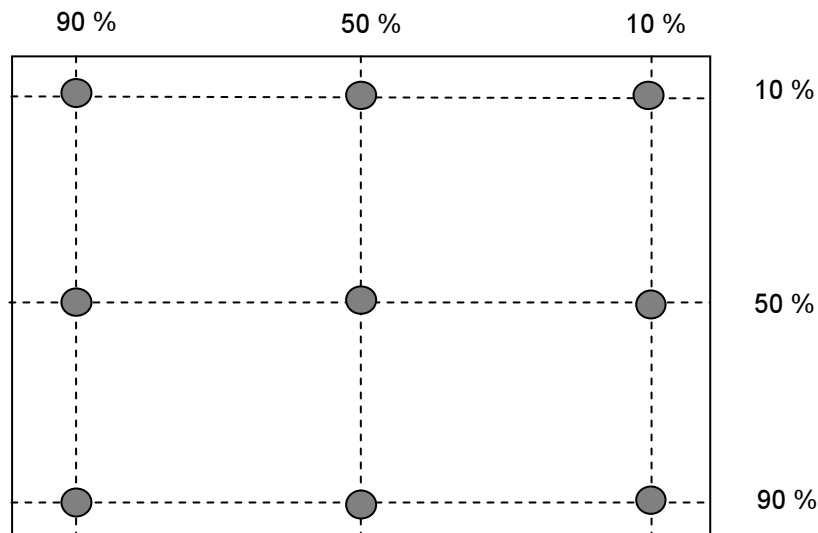

Note 3: The luminance uniformity of 9 points is defined by dividing the maximum luminance values by the minimum test point luminance

$$\delta_{w9} = \frac{\text{Minimum Luminance of 9 points}}{\text{Maximum Luminance of 9 points}}$$

Note 4: Measurement method

The LCD module should be stabilized at given temperature for 30 minutes to avoid abrupt temperature change during measuring. In order to stabilize the luminance, the measurement should be executed after lighting Backlight for 30 minutes in a stable, windless and dark room.

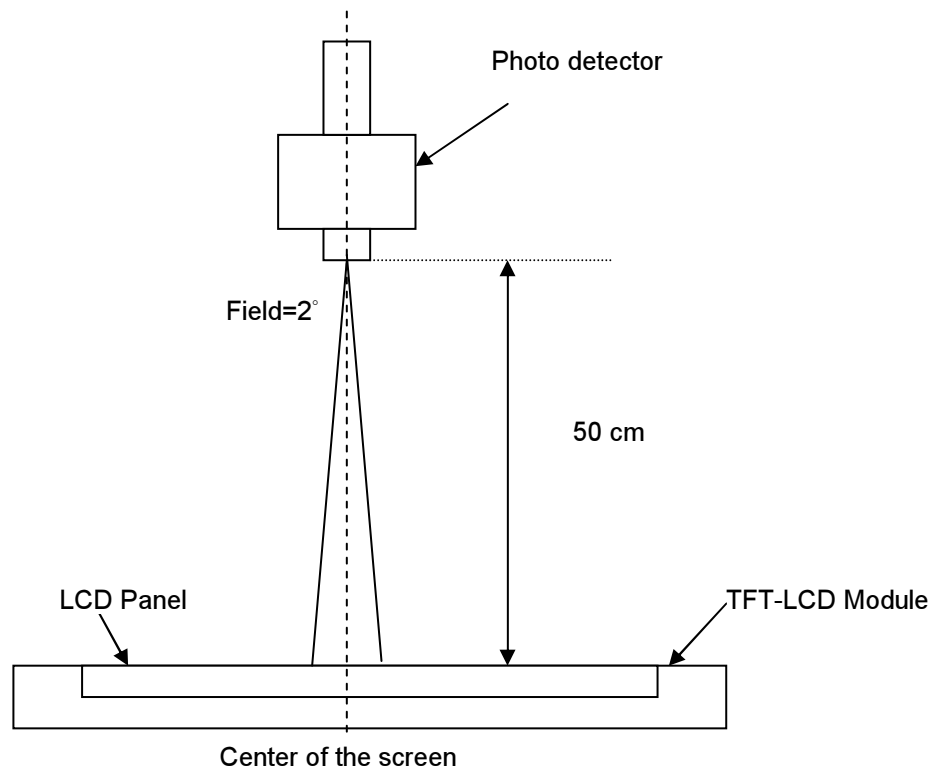

Note 5: Definition of Cross Talk (CT)

$$CT = | YB - YA | / YA \times 100 (\%)$$

Where

YA = Luminance of measured location without gray level 0 pattern (cd/m²)

YB = Luminance of measured location with gray level 0 pattern (cd/m²)

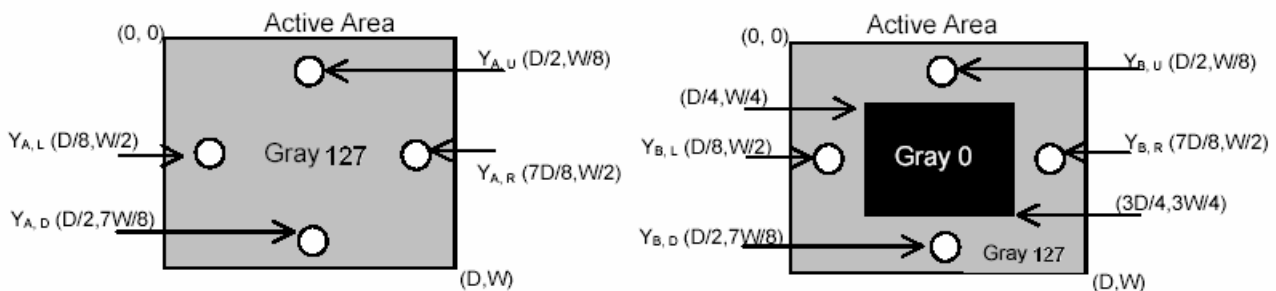

Note 6: Definition of response time:

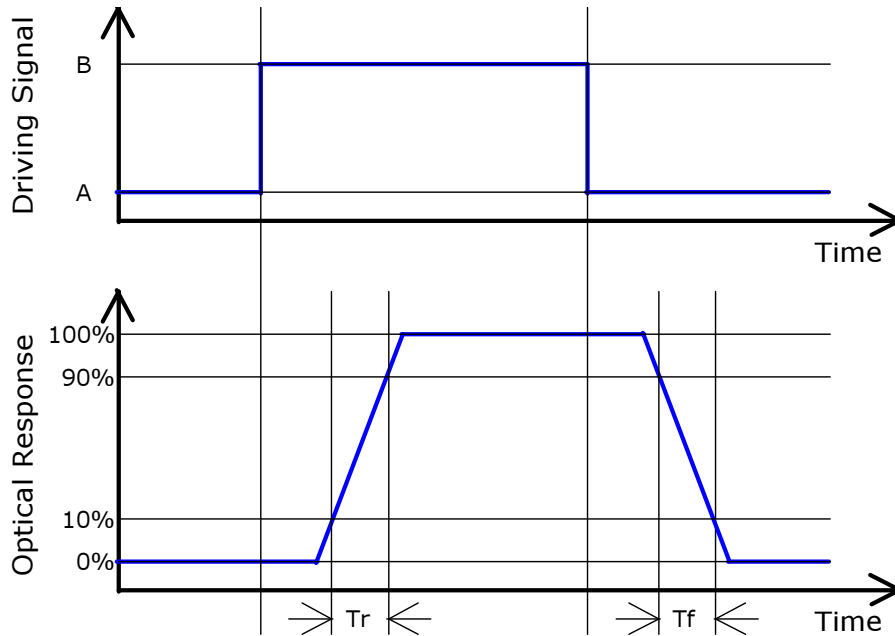

Algorithm:

$| \text{Level A} - \text{Level B} | \geq 16$ then the average of Grey-to-Grey response time is 8ms. (F= 60 Hz).

T_{rR} (rising time; from “All Black” to “All White”) + T_{rF} (Falling time; from “All White” to “All Black”) = 20ms(typ).

Note 7: Subchecker Pattern

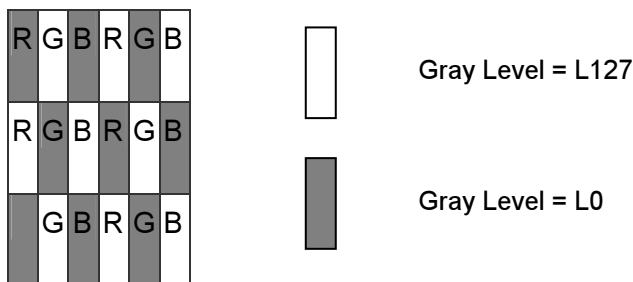

Method: Record dBV & DC value with (WESTAR)TRD-100

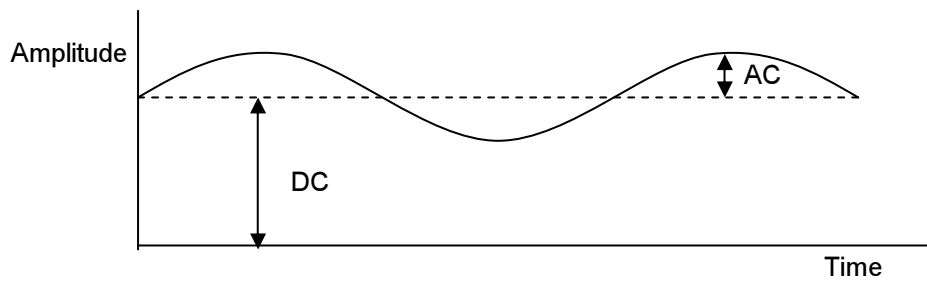

$$\text{Flicker (dB)} = 20 \log \frac{\text{AC Level(at 30 Hz)}}{\text{DC Level}}$$

Note 8: Color Grayscale Linearity

- a. Test image : 100% full white pattern with a test pattern as below
- b. Test pattern : Squares, 40mm by 40mm in size, filled with 255, 225, 195, 165, 135 and 105 grays steps should be arranged at the center of the screen.
- c. Test method
 - 1st gray scale : Move a square of 255 gray level should be moved into the center of the screen and measure luminance and u' and v' coordinates.
 - Next gray step : Move a 225 gray square into the center and measure both luminance and coordinates, too.
- d. Test evaluation

$$\Delta u'v' = \sqrt{(u'_A - u'_B)^2 + (v'_A - v'_B)^2}$$

Where A,B : 2 gray levels found to have the largest color differences between them

i.e. get largest $\Delta u'$ and $\Delta v'$ of each 6 pair of u' and v' and calculate $\Delta u'v'$



3. Functional Block Diagram

The following diagram shows the functional block of the 19.0 inches Color TFT-LCD Module:

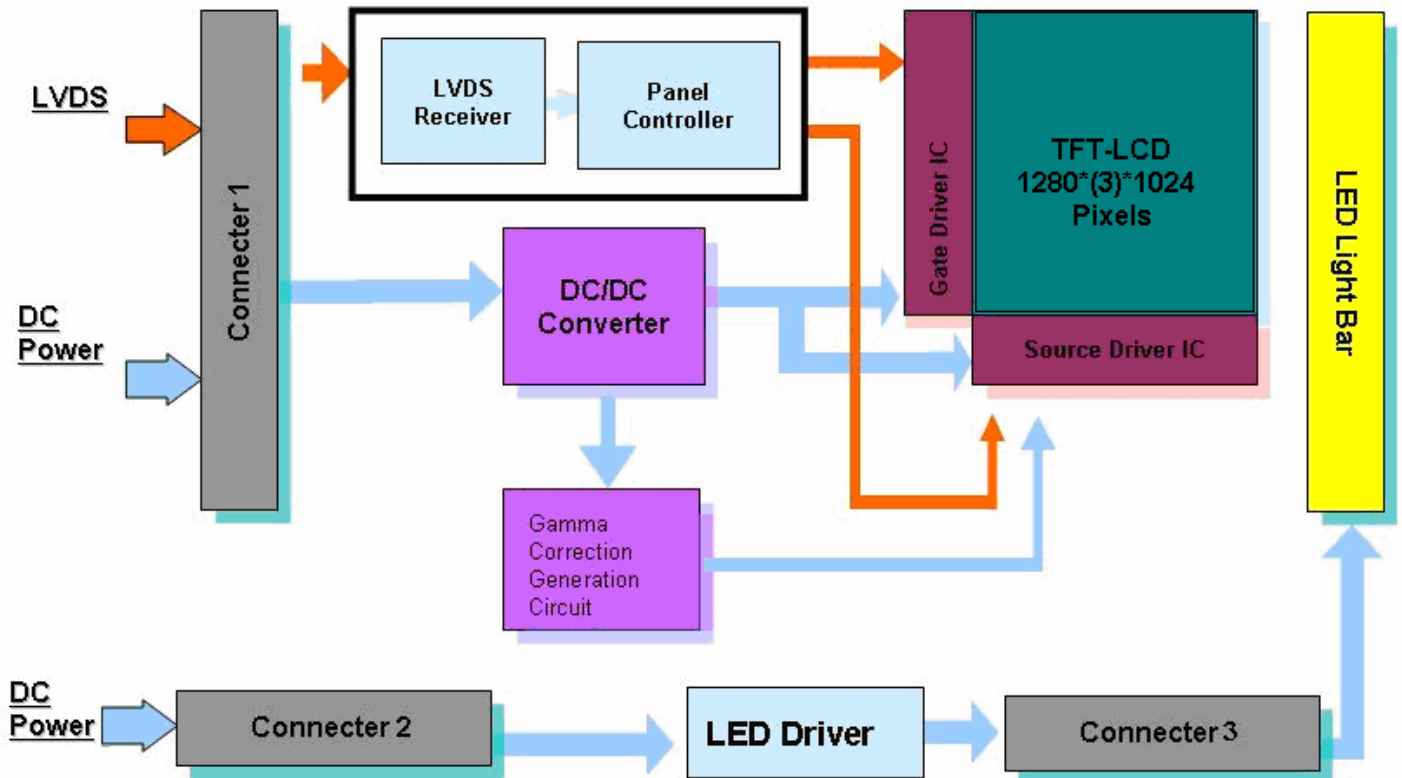

4. Absolute Maximum Ratings

Absolute maximum ratings of the module are as following:

4.1 Absolute Ratings of TFT LCD Module

Item	Symbol	Min.	Max.	Unit	Conditions
Logic/LCD Drive Voltage	VDD	-0.3	+6	[Volt]	Note 1, 2

4.2 Absolute Ratings of Backlight Unit

Item	Symbol	Min.	Max.	Unit	Conditions
LED Current	ILED	-	100	[mA] rms	Note 1, 2

4.3 Absolute Ratings of Environment

Item	Symbol	Min.	Max.	Unit	Conditions
Operating Temperature	TOP	0	+50	[°C]	Note 3
Operation Humidity	HOP	5	90	[%RH]	
Storage Temperature	TST	-20	+60	[°C]	
Storage Humidity	HST	5	90	[%RH]	

Note 1: With in $T_a = 25^\circ\text{C}$

Note 2: Permanent damage to the device may occur if exceed maximum values

Note 3: For quality performance, please refer to AUO IIS (Incoming Inspection Standard).

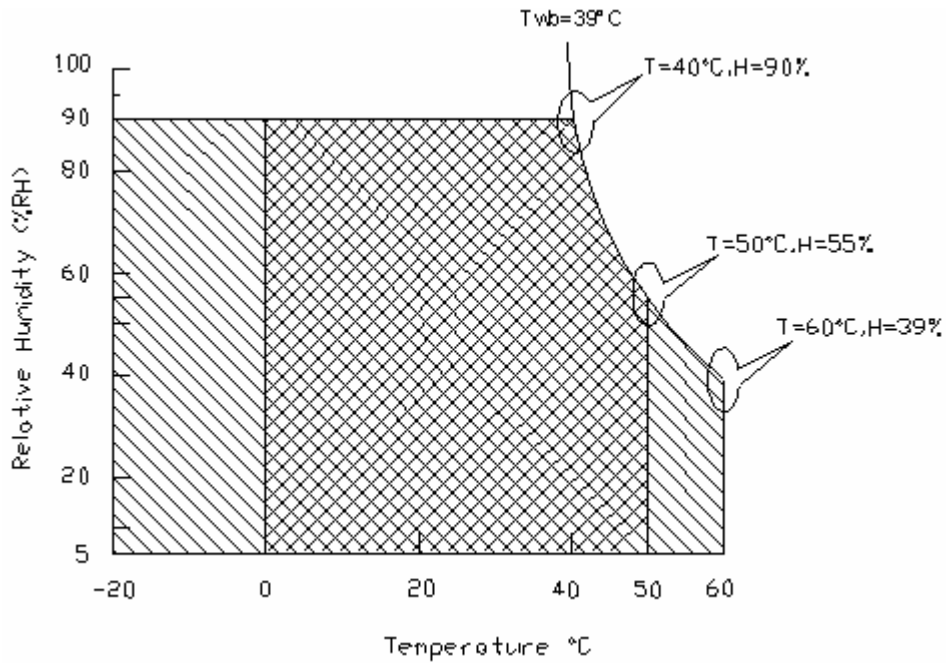

Operating Range



Storage Range

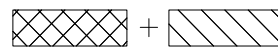

5. Electrical characteristics

5.1 TFT LCD Module

Input power specifications are as follows:

Symble	Parameter	Min.	Typ.	Max.	Unit	Condition
VDD	Logic/LCD Drive Voltage	4.5	5.0	5.5	[Volt]	±10%
IDD	Input Current	-	1.50	1.80	[A]	VDD= 5.0V, All White Pattern At 60Hz
PDD	VDD Power	-	7.5	9.0	[Watt]	VDD= 5.0V, All White Pattern At 60Hz , Note 1
IRush	Inrush Current	-	2	3	[A]	Note 2

Note 1: The variance of VDD power consumption is ±10%.

Note 2: Measurement conditions:

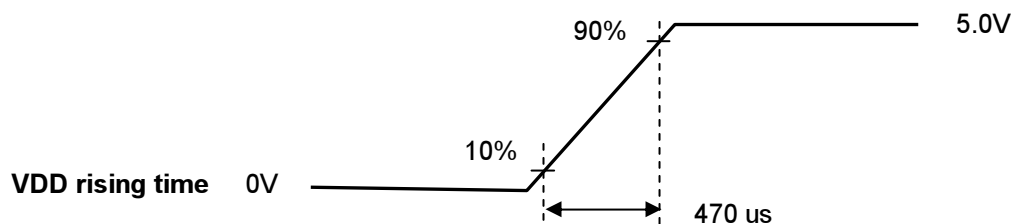
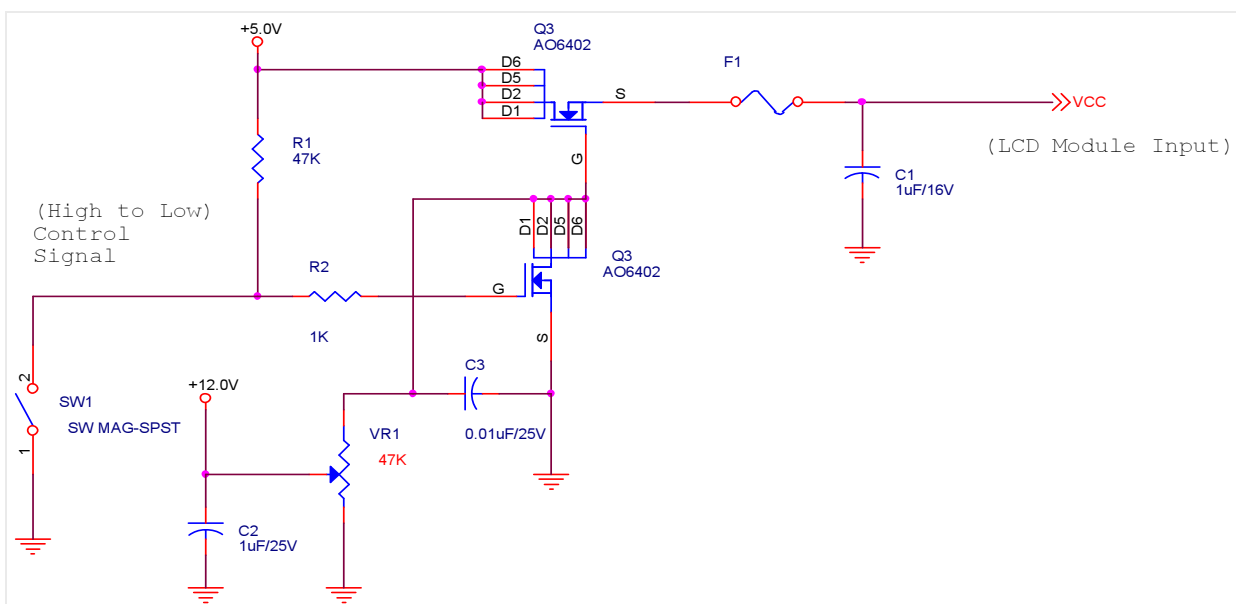

5.2 Backlight Unit

Following characteristics are measured under a stable condition at 25°C (Room Temperature):

Symbol	Parameter	Min.	Typ.	Max.	Unit	Remark
VCC	Input Voltage		12		[Volt]	
I _{VCC}	Input Current		3.96		[A]	100% PWM Duty
P _{VCC}	Power Consumption		47.5	51	[Watt]	100% PWM Duty
I _{rush LED}	Inrush Current	-	4.3	-	[A]	at rising time=470us
F _{PWM}	Dimming Frequency	200		20K	[Hz]	
	Swing Voltage	-	3.3	-	V	
	Dimming Duty Cycle	10	-	100	%	
I _F	LED Forward Current		100		mA	Ta = 25°C
V _F	LED Forward Voltage	-	-	-	Volt	
		-	3.33	-	Volt	I _F =100mA, Ta = 25°C
		-	-	-		
P _{LED}	LED Power Consumption	-	40	-	Watt	I _F =100 mA, Ta = 25°C
Operation Lifetime		50,000			Hrs	I _F =100mA, Ta= 25°C

Note 1: Ta means ambient temperature of TFT-LCD module.

Note 2: VCC, I_{VCC}, P_{VCC}, I_{rush LED} are defined for LED B/L.(100% duty of PWM dimming)

Note 3: I_F, V_F, P_{LED} are defined for LED Light Bar. There is two LED channel (AN1-CA1-CA2) in back light unit.

Note 4: If G190EG02 V0 module is driven by high current or at high ambient temperature & humidity condition. The operating life will be reduced.

Note 5: Operating life means brightness goes down to 50% initial brightness. Minimum operating life time is estimated data.

6. Signal Characteristic

6.1 Pixel Format Image

Following figure shows the relationship of the input signals and LCD pixel format.

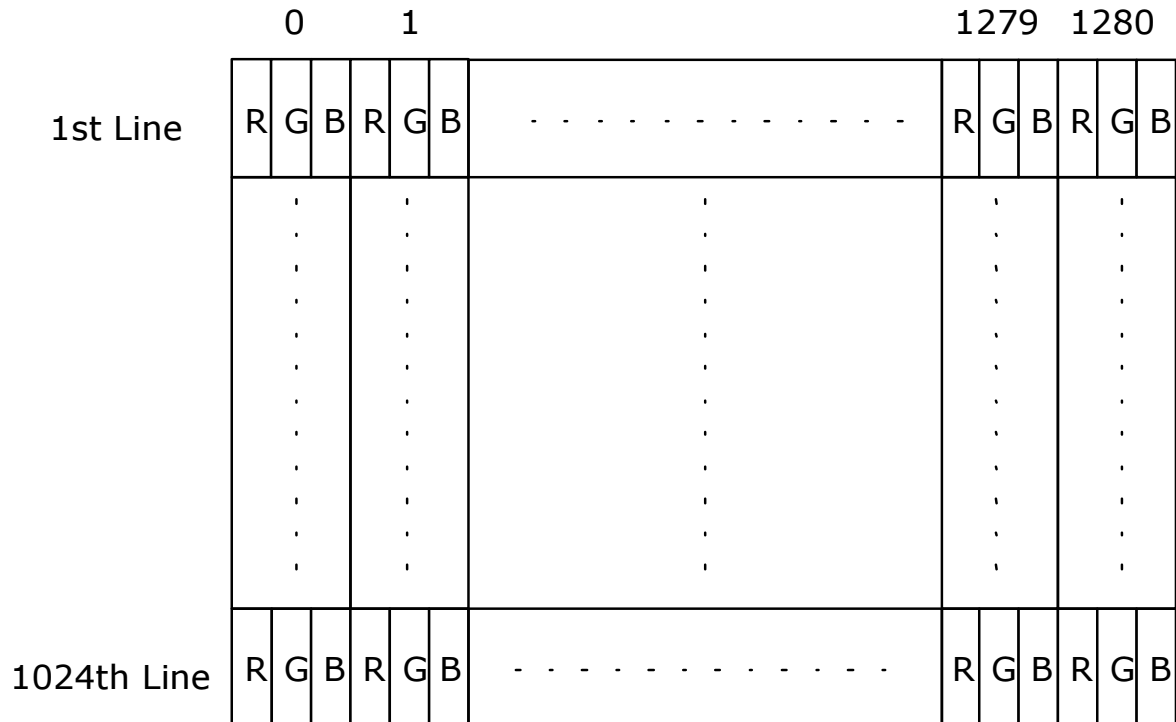

6.2 The Input Data Format

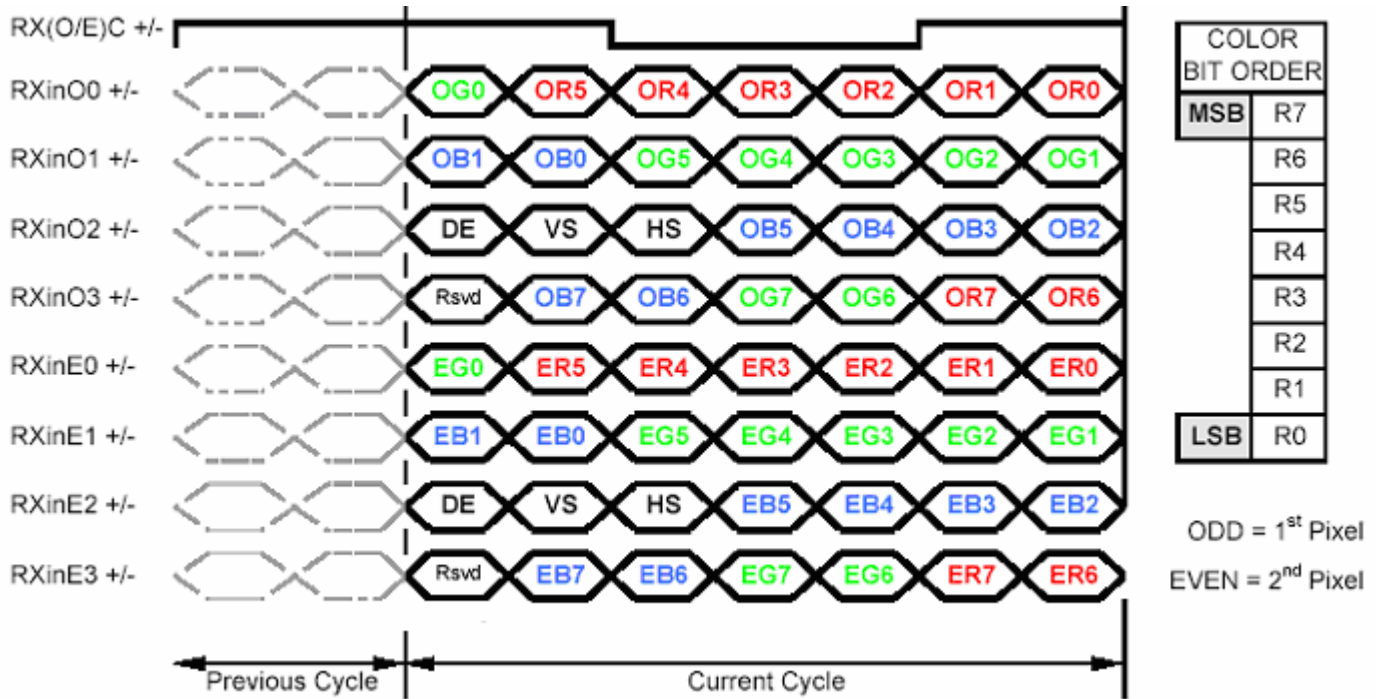

Note1: Normally, DE, VS, HS on EVEN channel are not used.

Note2: Please follow VESA.

Note3: 8-bit in

6.3 Signal Description

The module using a pair of LVDS receiver SN75LVDS82(Texas Instruments) or compatible. LVDS is a differential signal technology for LCD interface and high speed data transfer device. Transmitter shall be SN75LVDS83(negative edge sampling) or compatible. The first LVDS port(RxOxxx) transmits odd pixels while the second LVDS port(RxExxx) transmits even pixels.

PIN #	SIGNAL NAME	DESCRIPTION
1	RxOIN0-	Negative LVDS differential data input (Odd data)
2	RxOIN0+	Positive LVDS differential data input (Odd data)
3	RxOIN1-	Negative LVDS differential data input (Odd data)
4	RxOIN1+	Positive LVDS differential data input (Odd data)
5	RxOIN2-	Negative LVDS differential data input (Odd data, H-Sync,V-Sync,DSPTMG)
6	RxOIN2+	Positive LVDS differential data input (Odd data, H-Sync,V-Sync,DSPTMG)
7	VSS	Power Ground
8	RxOCLKIN-	Negative LVDS differential clock input (Odd clock)
9	RxOCLKIN+	Positive LVDS differential clock input (Odd clock)
10	RxOIN3-	Negative LVDS differential data input (Odd data)
11	RxOIN3+	Positive LVDS differential data input (Odd data)
12	RxEIN0-	Negative LVDS differential data input (Even data)
13	RxEIN0+	Positive LVDS differential data input (Even data)
14	VSS	Power Ground
15	RxEIN1-	Negative LVDS differential data input (Even data)
16	RxEIN1+	Positive LVDS differential data input (Even data)
17	VSS	Power Ground
18	RxEIN2-	Negative LVDS differential data input (Even data)
19	RxEIN2+	Positive LVDS differential data input (Even data)
20	RxECLKIN-	Negative LVDS differential clock input (Even clock)
21	RxECLKIN+	Positive LVDS differential clock input (Even clock)
22	RxEIN3-	Negative LVDS differential data input (Even data)
23	RxEIN3+	Positive LVDS differential data input (Even data)
24	VSS	Power Ground
25	VSS	Power Ground
26	NC	No Connection (for AUO test)
27	VSS	Power Ground
28	VCC	+5.0V Power Supply
29	VCC	+5.0V Power Supply
30	VCC	+5.0V Power Supply

Note1: Start from left side

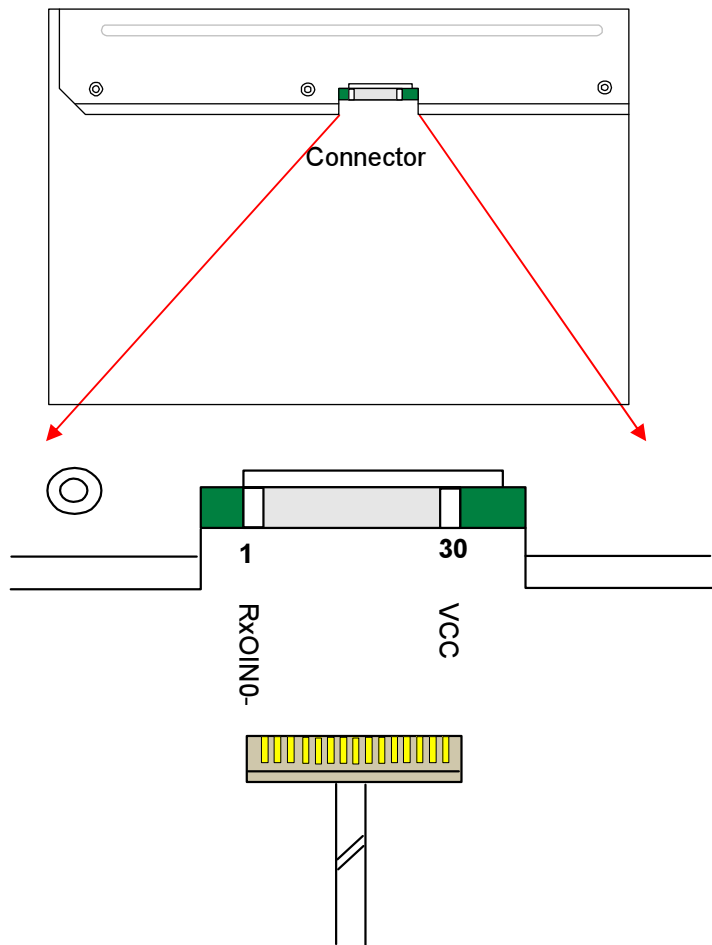

Note2: Input signals of odd and even clock shall be the same timing.

Note3: Please follow PSWG.

6.4 Interface Timing

6.4.1 Timing Characteristics

Basically, interface timings described here is not actual input timing of LCD module but output timing of SN75LVDS82DGG (Texas Instruments) or equivalent.

Item	Symbol	Min	Typ	Max	Unit	
Data CLK	Tclk	30	54	83	MHz	
H-section	Period	Th	720	844	1024	Tclk
	Display Area	Tdisp(h)	640	640	640	Tclk
V-section	Period	Tv	1035	1066	2048	Th
	Display Area	Tdisp(v)	1024	1024	1024	Th
Frame Rate	F	50	60	75	Hz	

Note : DE mode only

6.4.2 Timing Diagram

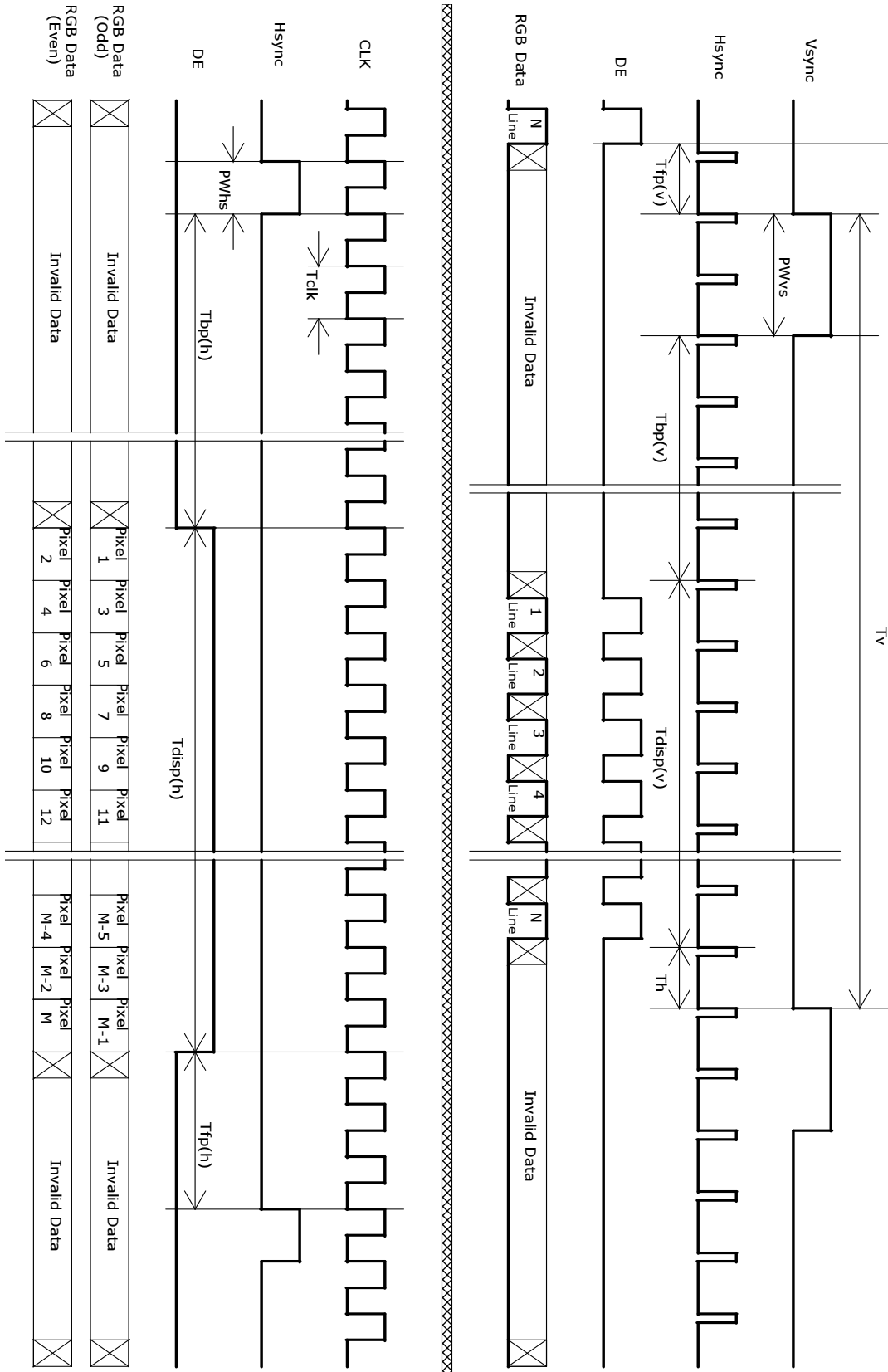

6.5 Power ON/OFF Sequence

VDD power and LED on/off sequence is as follows. Interface signals are also shown in the chart. Signals from any system shall be Hi-Z state or low level when VDD is off.

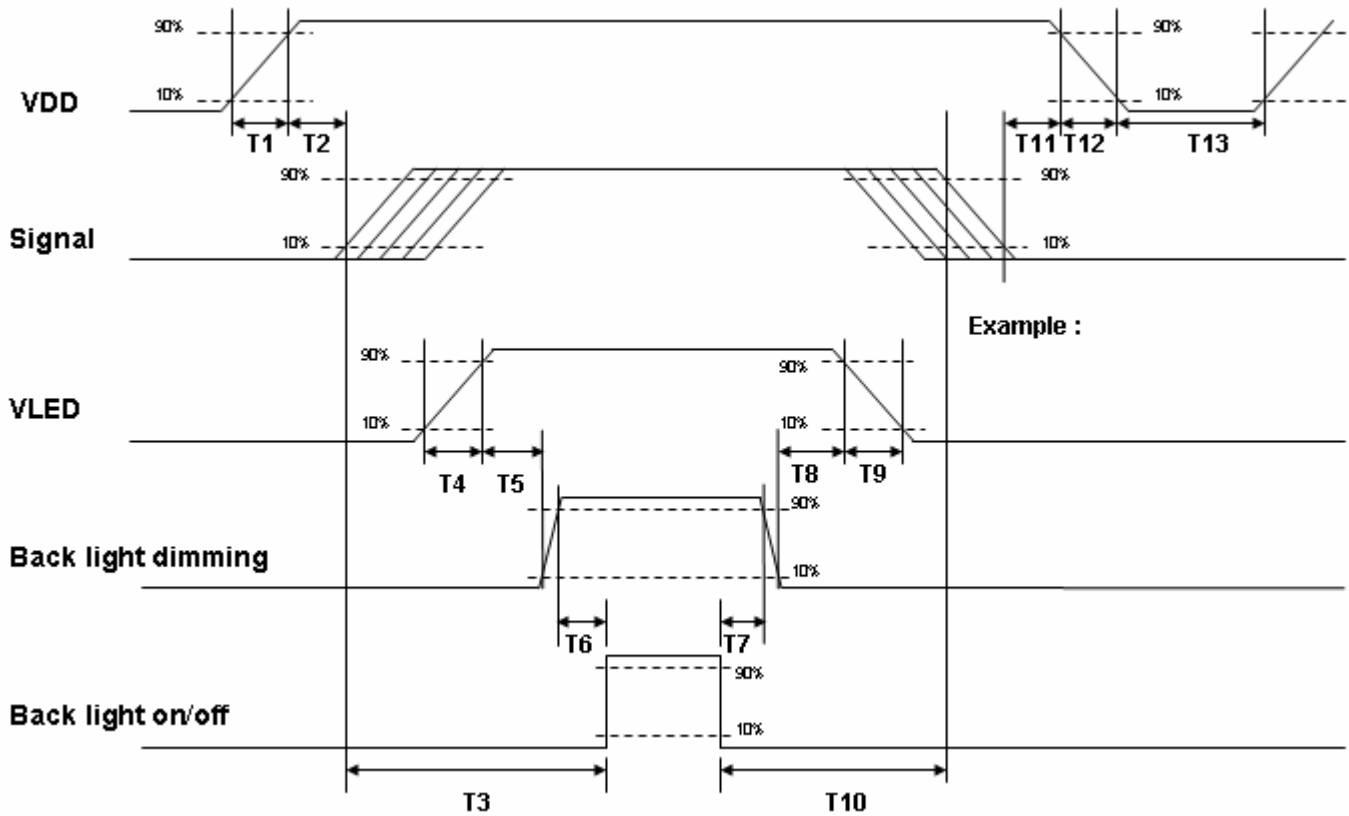

Power Sequence Timing

Parameter	Value			Units
	Min.	Typ.	Max.	
T1	0.5	--	10	[ms]
T2	30	40	50	[ms]
T3	200	--	--	[ms]
T4	0.5	--	10	[ms]
T5	10	--	--	[ms]
T6	10	--	--	[ms]
T7	0	--	--	[ms]
T8	10	--	--	[ms]
T9	--	--	10	[ms]
T10	110	--	--	[ms]
T11	0	16	50	[ms]
T12	--	--	10	[ms]
T13	1000	--	--	[ms]

Note: The values of the table are follow VESA.

7. Connector & Pin Assignment

Physical interface is described as for the connector on module. These connectors are capable of accommodating the following signals and will be following components.

7.1 TFT LCD Module

Connector Name / Designation	Interface Connector / Interface card
Manufacturer	JAE/ STM
Type Part Number	STM:MSBKT2407P30HB
Mating Housing Part Number	JAE: FI-X30HL STM:PK2407P30V

7.1.2 Pin Assignment

Pin#	Signal Name	Pin#	Signal Name
1	RxOIN0-	2	RxOIN0+
3	RxOIN1-	4	RxOIN1+
5	RxOIN2-	6	RxOIN2+
7	VSS	8	RxOCLKIN-
9	RxOCLKIN+	10	RxOIN3-
11	RxOIN3+	12	RxEIN0-
13	RxEIN0+	14	VSS
15	RxEIN1-	16	RxEIN1+
17	VSS	18	RxEIN2-
19	RxEIN2+	20	RxECLKIN-
21	RxECLKIN+	22	RxEIN3-
23	RxEIN3+	24	VSS
25	VSS	26	NC
27	VSS	28	VCC
29	VCC	30	VCC

7.2 Backlight Unit

Connector Name / Designation	Backlight Connector
Manufacturer	STM
Connector Model Number	STM: MS240415HJ
Mating Model Number	STM: P240415

7.2.1 Signal for LED connector

Pin #	Symbol	Pin Description
1	GND	GND
2	GND	GND
3	GND	GND
4	+12v	Power +12V
5	+12v	Power +12V
6	+12v	Power +12V
7	En	Enable On : 2.5V~5V Enable Off (max) : 0.8V
8	NC	NC
9	Dimming	High : 2.5V~5V; Low (max) : 0.8V PWM (duty 10%~ 100%)
10	+12v	Power +12V
11	+12v	Power +12V
12	+12v	Power +12V
13	GND	GND
14	GND	GND
15	GND	GND

8. Reliability Test

Environment test conditions are listed as following table.

Items	Required Condition	Note
Temperature Humidity Bias (THB)	Ta= 50°C, 80%RH, 300hours	
High Temperature Operation (HTO)	Ta= 50°C, 50%RH, 300hours	
Low Temperature Operation (LTO)	Ta= 0°C, 300hours	
High Temperature Storage (HTS)	Ta= 60°C, 300hours	
Low Temperature Storage (LTS)	Ta= -20°C, 300hours	
Vibration Test (Non-operation)	Acceleration: 1.5 G Wave: Random Frequency: 10 - 200 - 10 Hz Sweep: 30 Minutes each Axis (X, Y, Z)	
Shock Test (Non-operation)	Acceleration: 50 G Wave: Half-sine Active Time: 20 ms Direction: ±X, ±Y, ±Z (one time for each Axis)	
Drop Test	Height: 60 cm, package test	
Thermal Shock Test (TST)	-20°C /30min, 60°C /30min, 100 cycles	1
On/Off Test	On/10sec, Off/10sec, 30,000 cycles	
ESD (ElectroStatic Discharge)	Contact Discharge: ± 8KV, 150pF(330Ω) 1sec, 8 points, 25 times/ point.	2
	Air Discharge: ± 15KV, 150pF(330Ω) 1sec 8 points, 25 times/ point.	
Altitude Test	Operation:10,000 ft Non-Operation:30,000 ft	

Note 1: The TFT-LCD module will not sustain damage after being subjected to 100 cycles of rapid temperature change. A cycle of rapid temperature change consists of varying the temperature from -20°C to 60°C, and back again. Power is not applied during the test. After temperature cycling, the unit is placed in normal room ambient for at least 4 hours before power on.

Note 2: According to EN61000-4-2, ESD class B: Some performance degradation allowed. No data lost. Self-recoverable. No hardware failures.

9. Shipping Label

The shipping label format is shown as below.



10. Packing Form

Packaging material

FILM PROTECT
BAG ANTI-STATIC
TAPE
TAPE CREPED PAPER
PACKING CARTON
LABEL SPEC
LABEL CARTON.
CUSHION PACKING

Packing instruction

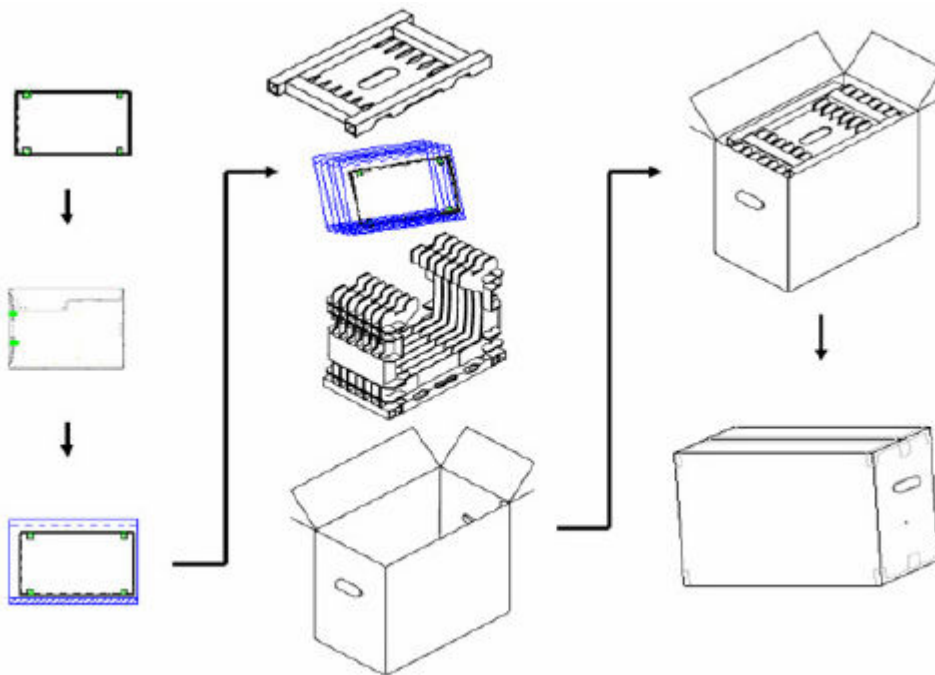

Max capacity : 6 TFT-LCD module per carton

Max weight: 16.5 kg per carton

Outside dimension of carton: 476mm(L)* 274mm(W)*413mm(H)

Pallet size : 1150 mm * 980 mm * 135mm

Box Stacked

Module by air : (2 *4) *3 layers , one pallet put 24 boxes , total 144pcs module

Module by sea : (2 *4) *3 layers + (2 *4) *1 layers , two pallet put 32 boxes , total 192pcs module

Module by sea_HQ : (2 *4) *3 layers+(2 *4) *2 layers, two pallet put 40 boxes, total 240pcs module

Palletizing

	MAX SHIPPING BY AIR	MAX SHIPPING BY SEA	MAX SHIPPING BY SEA_HQ
MODULE/CARTON	6	6	6
CARTON/LAYER	8	8	8
LAYER/PALLET	3	3+1	3+2
MODULE/PALLET	144	192	240
CARTON SIZE(MM)	476(L)*274(W)*413(H)	476(L)*274(W)*413(H)	476(L)*274(W)*413(H)
PALLET SIZE(MM)	1150(L)*980(W)*138(H)	1150(L)*980(W)*138(H)	1150(L)*980(W)*138(H)
TOTAL PALLET HEIGHT(MM)	1374	1922	2335
TOTAL PALLET WEIGHT(KG)	409	541	673

ONE PALLET SHIPMENT EXAMPLE SHIPPING BY AIR USED

TWO PALLETS SHIPMENT EXAMPLE SHIPPING BY SEA USED

TWO PALLETS SHIPMENT EXAMPLE SHIPPING BY SEA_HQ USED

Labels in diagrams: STRETCH FILM, PALLET, CORNER ANGLE, PET BAND.

11. Mechanical Characteristic

