



(V) Preliminary Specification

() Final Specification

Module	19" SXGA TFT-LCD Module
Model Name	G190ETN01.4

Customer	Date
_____	_____
Approved by	
_____	_____
<p>Note: This Specification is subject to change without notice.</p>	

Checked & Approved by	Date
Crystal Hsieh	2016/01/12
Prepared by	Date
Wennie Lee	2016/01/12
<p>Audio-Video Display Business Unit / AU Optronics corporation</p>	



Contents

1. Handling Precautions..... 4

2. General Description 5

2.1 Display Characteristics 5

2.2 Optical Characteristics..... 6

3. Functional Block Diagram 9

4. Absolute Maximum Ratings..... 10

4.1 TFT LCD Module 10

4.2 Absolute Ratings of Environment 10

5. Electrical Characteristics..... 11

5.1 TFT LCD Module 11

6. Signal Characteristic..... 14

6.1 Pixel Format Image 14

6.2 The Input Data Format 14

6.3 Signal Description..... 15

6.4 Interface Timing..... 17

6.5 Power ON/OFF Sequence..... 18

7. Connector and Pin Assignment 19

7.1 TFT LCD Module 19

7.2 Backlight Unit..... 20

8. Reliability Test 21

9. Label and Packing 22

9.1. Shipping Label..... 22

9.2 Packing Form 22

9.3 Palletizing Sequence 23

10. Outline Drawing..... 24



Record of Revision

Version & Date	Page	Old Description	New Description																																																																
0.0 2014/11/26	All	Frist Preliminary Spec																																																																	
0.1 2014/12/05	20	Manufacturer: ENTRY	STM																																																																
0.2 2015/02/12	13		Add: VLED ON/OFF																																																																
	20		Modify: 7.2.1 connector																																																																
			Modify: 7.2.2 pin assignment																																																																
	24		Update drawing																																																																
	25		Update drawing																																																																
0.3 2015/6/25	5	Power Consumption: 20.6 W	20W (Typ)																																																																
		Physical Size:396(H)x324(V)x 13(D) (max)	396 (H) x 324 (V) x 12.88(D) (typ)																																																																
	6	Viewing Angle, CR ≥ 10	CR ≥ 5																																																																
		<table border="1"> <tr><td>Red x</td><td>TBD</td><td>TBD</td><td>TBD</td></tr> <tr><td>Red y</td><td>TBD</td><td>TBD</td><td>TBD</td></tr> <tr><td>Green x</td><td>TBD</td><td>TBD</td><td>TBD</td></tr> <tr><td>Green y</td><td>TBD</td><td>TBD</td><td>TBD</td></tr> <tr><td>Blue x</td><td>TBD</td><td>TBD</td><td>TBD</td></tr> <tr><td>Blue y</td><td>TBD</td><td>TBD</td><td>TBD</td></tr> <tr><td>White x</td><td>TBD</td><td>TBD</td><td>TBD</td></tr> <tr><td>White y</td><td>TBD</td><td>TBD</td><td>TBD</td></tr> </table>	Red x	TBD	TBD	TBD	Red y	TBD	TBD	TBD	Green x	TBD	TBD	TBD	Green y	TBD	TBD	TBD	Blue x	TBD	TBD	TBD	Blue y	TBD	TBD	TBD	White x	TBD	TBD	TBD	White y	TBD	TBD	TBD	<table border="1"> <tr><td>Red x</td><td>0.620</td><td>0.670</td><td>0.720</td></tr> <tr><td>Red y</td><td>0.272</td><td>0.322</td><td>0.372</td></tr> <tr><td>Green x</td><td>0.246</td><td>0.296</td><td>0.346</td></tr> <tr><td>Green y</td><td>0.615</td><td>0.665</td><td>0.715</td></tr> <tr><td>Blue x</td><td>0.104</td><td>0.154</td><td>0.204</td></tr> <tr><td>Blue y</td><td>0.001</td><td>0.038</td><td>0.088</td></tr> <tr><td>White x</td><td>0.263</td><td>0.313</td><td>0.363</td></tr> <tr><td>White y</td><td>0.279</td><td>0.329</td><td>0.379</td></tr> </table>	Red x	0.620	0.670	0.720	Red y	0.272	0.322	0.372	Green x	0.246	0.296	0.346	Green y	0.615	0.665	0.715	Blue x	0.104	0.154	0.204	Blue y	0.001	0.038	0.088	White x	0.263	0.313	0.363	White y	0.279	0.329	0.379
Red x	TBD	TBD	TBD																																																																
Red y	TBD	TBD	TBD																																																																
Green x	TBD	TBD	TBD																																																																
Green y	TBD	TBD	TBD																																																																
Blue x	TBD	TBD	TBD																																																																
Blue y	TBD	TBD	TBD																																																																
White x	TBD	TBD	TBD																																																																
White y	TBD	TBD	TBD																																																																
Red x	0.620	0.670	0.720																																																																
Red y	0.272	0.322	0.372																																																																
Green x	0.246	0.296	0.346																																																																
Green y	0.615	0.665	0.715																																																																
Blue x	0.104	0.154	0.204																																																																
Blue y	0.001	0.038	0.088																																																																
White x	0.263	0.313	0.363																																																																
White y	0.279	0.329	0.379																																																																
		NTSC: TBD	90%																																																																
	10		Add humidity graph																																																																
	13	I _{VCC} : 1.5(typ); 1.65(max)	1.25(typ); 1.35(max)																																																																
		P _{VCC} : 18(typ); 1.98(max)	15(typ); 16.2(max)																																																																
		V _F : 36.4(min); 40.3(typ.); 44.2(max)	33.6(min); 38.4(typ.); 43.2(max)																																																																
		P _{LED} : 16.12(typ);	15.36(typ);																																																																
	19	DF14H-30P-1.25H	DF14H-30P-1.25H(56)																																																																
		SM08B-GHH-TB	SM08B-GHH (HF)																																																																
		GHR-08V-S	GHR-08V-S (HF)																																																																
0.4 2015/7/30	19	GHR-08V-S (HF)	GHR-08V-S																																																																
0.5 2016/01/12	9		Update functional block drawing																																																																

1. Handling Precautions

- 1) Since front polarizer is easily damaged, please be cautious and not to scratch it.
- 2) Be sure to turn off power supply when inserting or disconnecting from input connector.
- 3) Wipe off water drop immediately. Long contact with water may cause discoloration or spots.
- 4) When the panel surface is soiled, wipe it with absorbent cotton or soft cloth.
- 5) Since the panel is made of glass, it may be broken or cracked if dropped or bumped on hard surface.
- 6) To avoid ESD (Electro Static Discharge) damage, be sure to ground yourself before handling TFT-LCD Module.
- 7) Do not open nor modify the module assembly.
- 8) Do not press the reflector sheet at the back of the module to any direction.
- 9) In case of a module has to be put back into the packing container slot after it was taken out from the container, do not press the center of the LED light bar edge. Instead, press at the far ends of the LED light bar edge softly. Otherwise the TFT Module may be damaged.
- 10) At the insertion or removal of the Signal Interface Connector, be sure not to rotate nor tilt the Interface Connector of the TFT Module.
- 11) TFT-LCD Module is not allowed to be twisted & bent even force is added on module in a very short time. Please design your display product well to avoid external force applying to module by end-user directly.
- 12) Small amount of materials without flammability grade are used in the TFT-LCD module. The TFT-LCD module should be supplied by power complied with requirements of Limited Power Source (IEC60950-1 or UL60950-1), or be applied exemption.
- 13) Continuous operating TFT-LCD display under high temperature environment may accelerate lamp exhaustion and reduce luminance dramatically.
- 14) Continuous displaying fixed pattern may induce image sticking. It's recommended to use screen saver or shuffle content periodically if fixed pattern is displayed on the screen.

2. General Description

G190ETN01.4 is a Color Active Matrix Liquid Crystal Display composed of a TFT-LCD panel, a driver circuit, and a backlight system. The screen format is intended to support the SXGA (1280(H) x 1024(V)) screen and 16.7M colors (RGB 6-bits + HiFRC data). All input signals are 2-channel LVDS interface.

2.1 Display Characteristics

The following items are characteristics summary on the table under 25 °C condition:

Items	Unit	Specifications
Screen Diagonal	[mm]	482.6 (19.0")
Active Area	[mm]	376.32 (H) x 301.06 (V)
Pixels H x V		1280(x3) x 1024
Pixel Pitch	[mm]	0.294 (per one triad) x 0.294
Pixel Arrangement		R.G.B. Vertical Stripe
Display Mode		Normally White
White Luminance	[cd/m ²]	450 (center, Typ)
Contrast Ratio		1000 : 1 (Typ)
Optical ResponseTime	[msec]	10 ms(Typ, on/off)
Nominal Input Voltage VDD	[Volt]	+5.0 V
Power Consumption	[Watt]	20W (Typ)
Weight	[Grams]	1800 (Typ)
Physical Size (H x V x D)	[mm]	396 (H) x 324 (V) x 12.88(D) (typ)
Electrical Interface		Dual channel LVDS
Surface Treatment		Anti-glare, Hardness 3H
Support Color		16.7M colors (RGB 6-bit + Hi_FRC)
Temperature Range		
Operating	[°C]	-30 to +85
Storage (Non-Operating)	[°C]	-30 to +85
RoHS Compliance		RoHS Compliance

2.2 Optical Characteristics

The optical characteristics are measured under stable conditions at 25°C (Room Temperature).

Item	Unit	Conditions	Min.	Typ.	Max.	Note
Viewing Angle	[degree]	Horizontal (Right) CR ≥ 5 (Left)	75 75	85 85	-	1
		Vertical (Up) CR ≥ 5 (Down)	70 70	80 80	-	
Contrast Ratio		Normal Direction	600	1000	-	
Central Luminance	[cd/m ²]		360	450	-	2
Optical Response Time	[msec]	Raising Time (TrR)	-	7	12	3
		Falling Time (TrF)	-	3	8	
		Rising + Falling	-	10	20	
Color / Chromaticity Coordinates (CIE)		Red x	0.620	0.670	0.720	
		Red y	0.272	0.322	0.372	
		Green x	0.246	0.296	0.346	
		Green y	0.615	0.665	0.715	
		Blue x	0.104	0.154	0.204	
		Blue y	0.001	0.038	0.088	
		White x	0.263	0.313	0.363	
White y	0.279	0.329	0.379			
Luminance Uniformity	[%]	9 Points	75	80	-	4,5
NTSC	[%]		-	90	-	

Optical Equipment: BM-5A, BM-7, PR880, or equivalent

Note 1: Definition of viewing angle

Viewing angle is the measurement of contrast ratio ≥ 10 , or ≥ 5 , at the screen center, over a 180° horizontal and 180° vertical range (off-normal viewing angles). The 180° viewing angle range is broken down as follows; 90° (θ) horizontal left and right and 90° (Φ) vertical, high (up) and low (down). The measurement direction is typically perpendicular to the display surface with the screen rotated about its center to develop the desired measurement viewing angle.

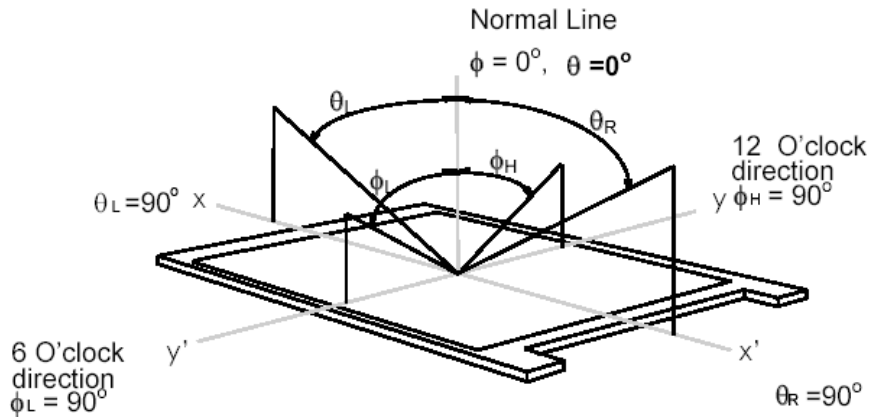

Note 2: Measurement method

The LCD module should be stabilized at given temperature for 30 minutes to avoid abrupt temperature change during measuring. In order to stabilize the luminance, the measurement should be executed after lighting Backlight for 30 minutes in a stable, windless and dark room.

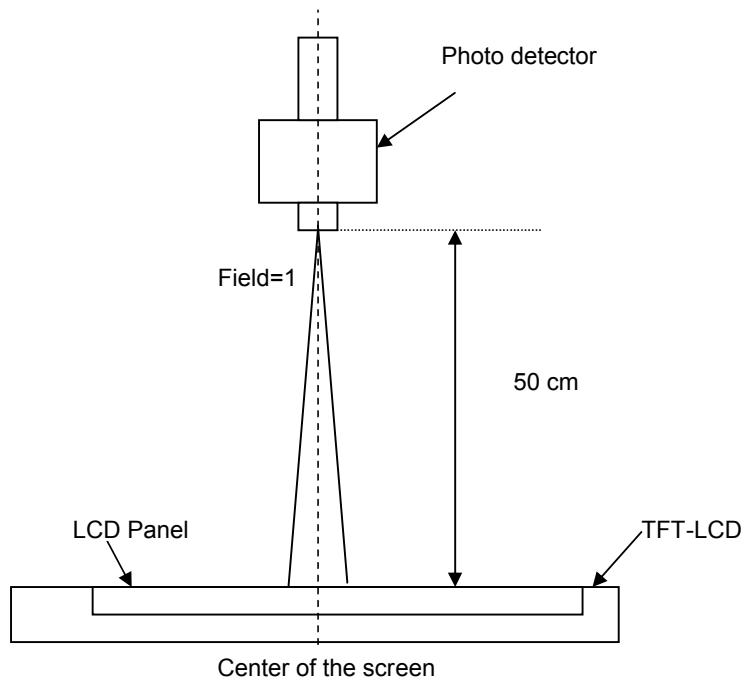

Note 3: Definition of response time:

The output signals of photo detector are measured when the input signals are changed from “Full Black” to “Full White” (rising time), and from “Full White” to “Full Black” (falling time), respectively. The response time is interval between the 10% and 90% of amplitudes. Please refer to the figure as below.

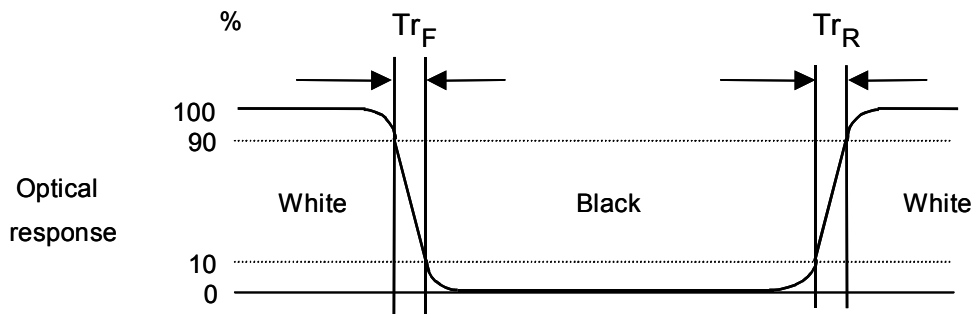

Note 4: 9 points position

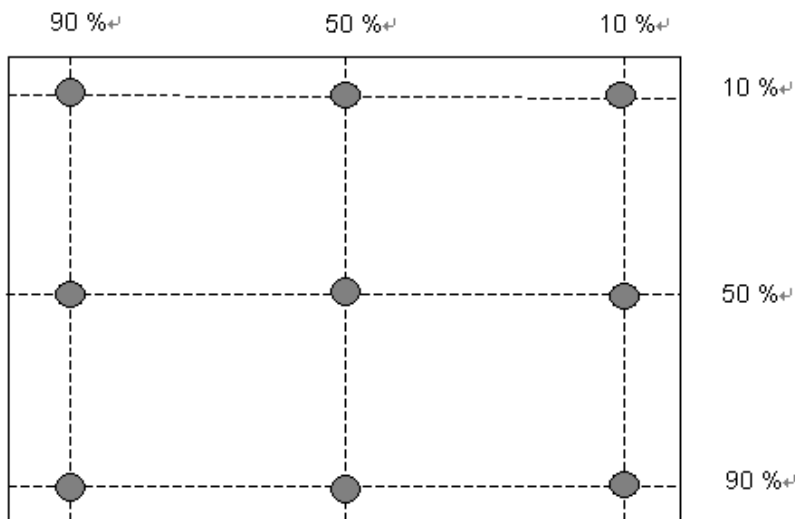

Note 5:

$$\text{Uniformity} = \frac{\text{Minimum Luminance in 9 points (1 - 9)}}{\text{Maximum Luminance in 9 Points (1 - 9)}}$$

3. Functional Block Diagram

The following diagram shows the functional block of the 19.0 inches wide Color TFT-LCD Module:

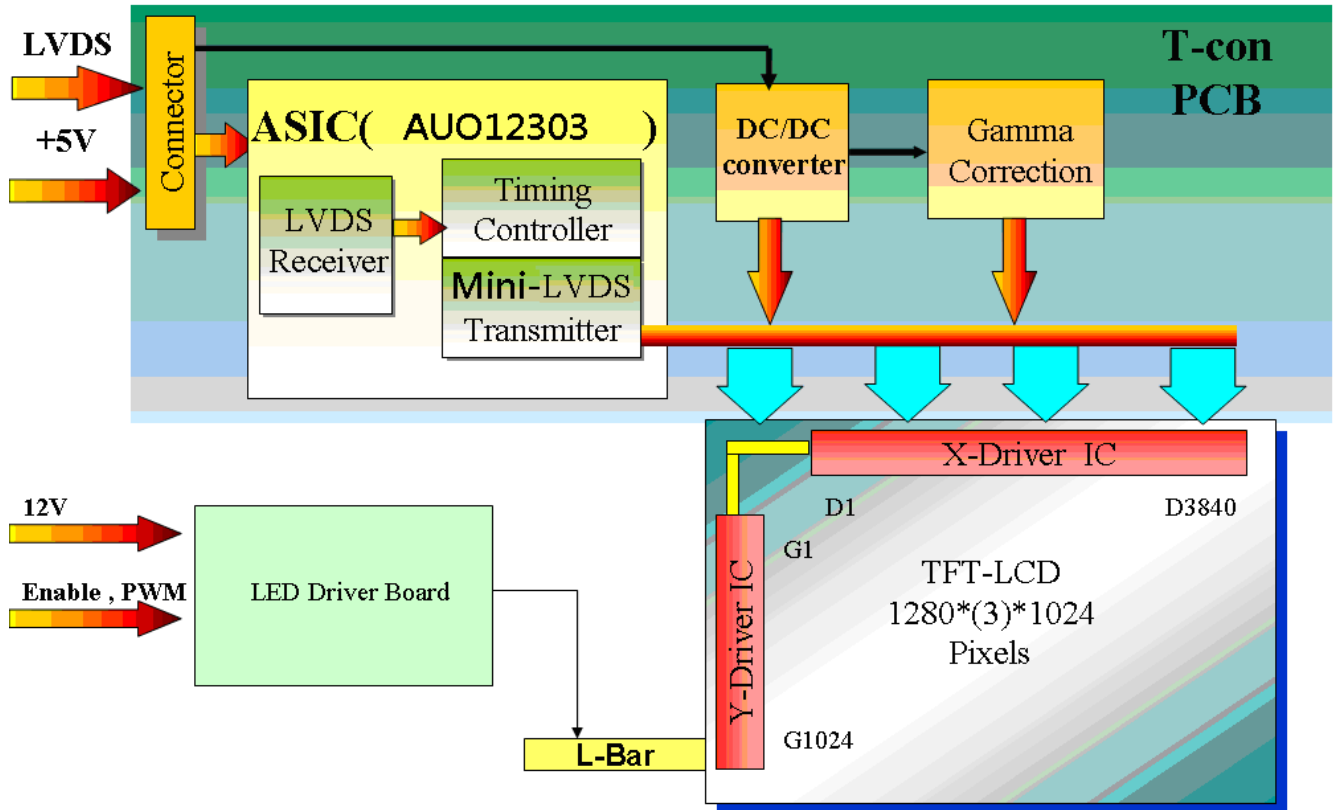

4. Absolute Maximum Ratings

Absolute maximum ratings of the module are as following:

4.1 TFT LCD Module

Item	Symbol	Min	Max	Unit	Conditions
Logic/LCD Drive Voltage	VDD	-0.3	+6.0	[Volt]	Note 1,2

4.2 Absolute Ratings of Environment

Item	Symbol	Min.	Max.	Unit	Conditions
Operating Temperature	TOP	-30	+85	[°C]	Note 3
Operation Humidity	HOP	5	95	[%RH]	Note 3
Storage Temperature	TST	-30	+85	[°C]	
Storage Humidity	HST	5	95	[%RH]	

Note 1: With in Ta (25°C)

Note 2: Permanent damage to the device may occur if exceeding maximum values

Note 3: Temperature and relative humidity range are shown as the below figure

1. 95% RH Max (Ta ≤ 39°C)
2. Max wet-bulb temperature at 39°C or less. (Ta ≤ 39°C)
3. No condensation

Note 4: Function Judged only

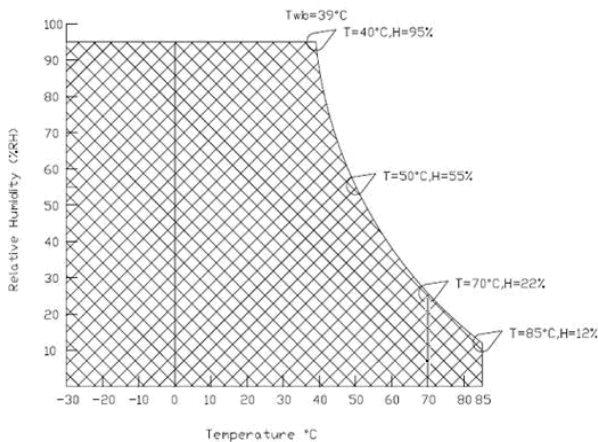

5. Electrical Characteristics

5.1 TFT LCD Module

5.1.1 Power Specification

Input power specifications are as follows:

Symbol	Parameter	Min	Typ	Max	Unit	Conditions
VDD	Logic/LCD Drive Voltage	4.5	5.0	5.5	[Volt]	+/-10%
IDD	Input Current	-	1	1.2	[A]	VDD= 5.0V, All Black Pattern At 75Hz
PDD	VDD Power	-	5	6	[Watt]	VDD= 5.0V, All Black Pattern At 75Hz
IRush	Inrush Current	-	-	3.0	[A]	Note 1
VDDrp	Allowable Logic/LCD Drive Ripple Voltage	-	-	100	[mV] p-p	VDD= 5.0V, All Black Pattern At 75Hz

Note 1: Measurement conditions:

The duration of rising time of power input is 470us.

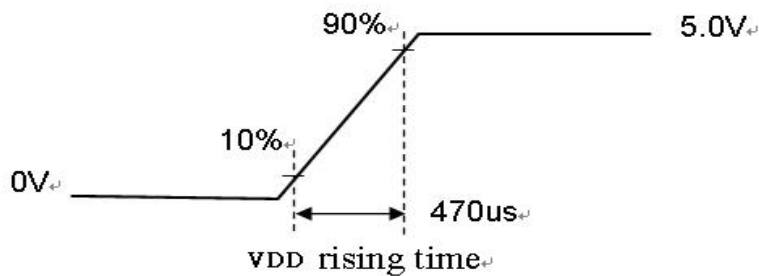
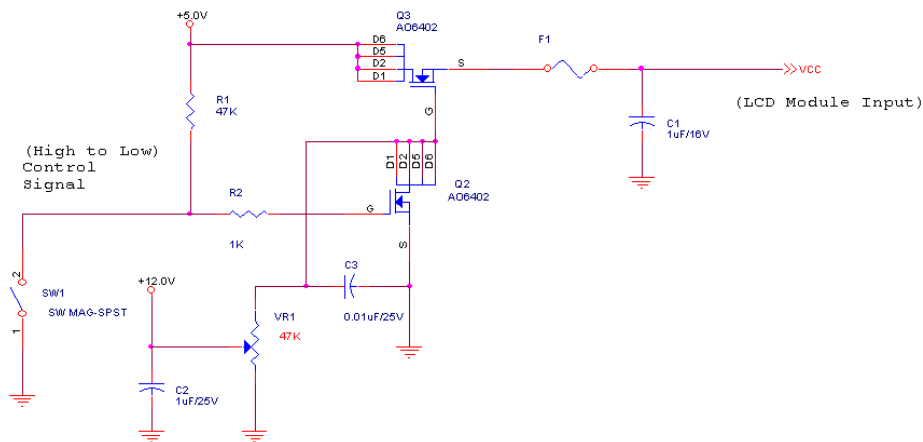

5.1.2 Signal Electrical Characteristics

Input signals shall be low or Hi-Z state when VDD is off. Please refer to specifications of SN75LVDS82DGG (Texas Instruments) in detail.

Each signal characteristics are as follows;

Symbol	Parameter	Min	Typ	Max	Units	Condition
V_{TH}	Differential Input High Threshold	-	-	+100	[mV]	$V_{CM} = 1.2V$ Note 1
V_{TL}	Differential Input Low Threshold	-100	-	-	[mV]	$V_{CM} = 1.2V$ Note 1
$ V_{ID} $	Input Differential Voltage	100	400	600	[mV]	Note 1
V_{CM}	Differential Input Common Mode Voltage	+1.0	+1.2	+1.5	[V]	$V_{TH} - V_{TL} = 200mV$ (max) Note 1

Note1: LVDS Signal Waveform

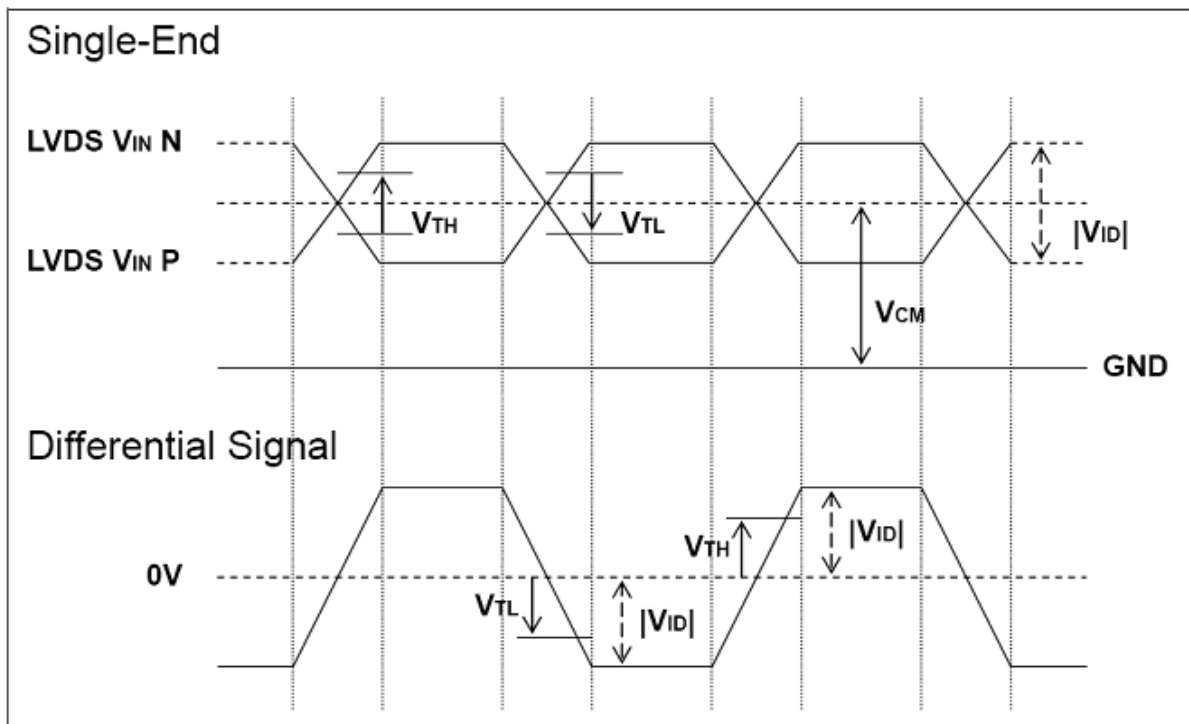

5.1.3 Backlight Unit

Parameter guideline for LED driving is under stable conditions at 25°C (Room Temperature):

Symbol	Parameter	Min.	Typ.	Max.	Unit	Remark
VCC	Input Voltage	10.8	12	13.4	[Volt]	
I _{VCC}	Input Current	-	1.25	1.35	[A]	100% PWM Duty
P _{VCC}	Power Consumption	-	15	16.2	[Watt]	100% PWM Duty
F _{PWM}	Dimming Frequency	200	-	20K	[Hz]	
	Swing Voltage	3	3.3	5	[Volt]	
	Dimming duty cycle	5	-	100	%	
V _{LED ON/OFF}	On Control Voltage	3.0	3.3	5	Volt	Note 7, 8
	Off Control Voltage	0	0	0.8	Volt	
I _F	LED Forward Current	-	100	-	[mA]	Ta = 25°C
V _F	LED Forward Voltage	-	-	-	[Volt]	I _F = 100mA, Ta = 0°C
		33.6	38.4	43.2	[Volt]	I _F = 100mA, Ta = 25°C
		-	-	-	[Volt]	I _F = 100mA, Ta = 70°C
P _{LED}	LED Power Consumption	-	15.36	-	[Watt]	
LED Life Time			50,000	-	Hrs	I _F =100mA, Ta= 25°C

Note 1: Ta means ambient temperature of TFT-LCD module.

Note 2: VCC, ICC, PCC are defined for LED backlight.(100% duty of PWM dimming)

Note 3: I_F, V_F are defined for one channel LED. There are four LED channels in back light unit.

Note 4: If G190ETN01.4 module is driven by high current or at high ambient temperature & humidity condition. The operating life will be reduced.

Note 5: Operating life means brightness goes down to 50% initial brightness. Minimum operating life time is estimated data.

Note 6: The definition of single LED life time is: brightness decreased to 50% of initial value. LED life time is restricted under normal condition, ambient temperature = 25°C and LED operating I_F = 100mA.

Note 7: Enable (V_{LED ON/Off}) must be turned on later than V_{LED} and PWM Signal.

Note 8: Enable (V_{LED ON/Off}) must be turned off earlier than V_{LED} and PWM Signal.

6. Signal Characteristic

6.1 Pixel Format Image

Following figure shows the relationship of the input signals and LCD pixel format.

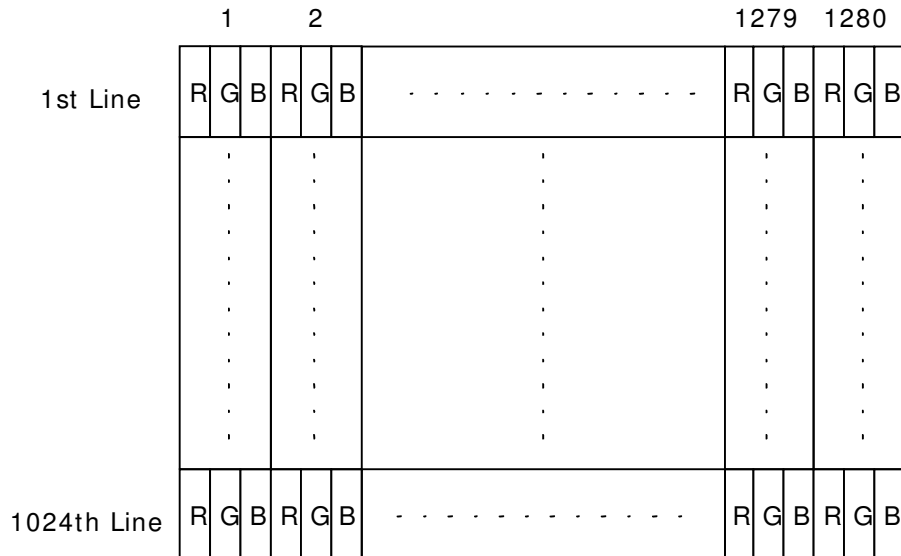

6.2 The Input Data Format

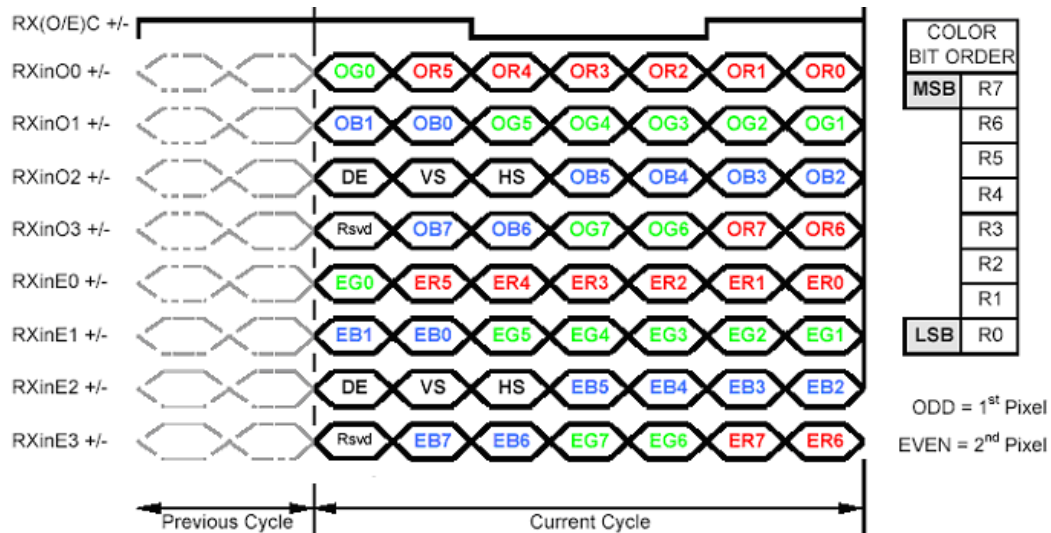

Note1: DE only , VS, HS on EVEN channel are not used.

Note2: Please follow PSWG.

Note3: 8-bit in

6.3 Signal Description

The module using one LVDS receiver SN75LVDS82(Texas Instruments). LVDS is a differential signal technology for LCD interface and high speed data transfer device. LVDS transmitters shall be SN75LVDS83(negative edge sampling). The first LVDS port(RxOxxx) transmits odd pixels while the second LVDS port(RxExxx) transmits even pixels.

PIN #	SIGNAL NAME	DESCRIPTION
1	RxOIN0-	Negative LVDS differential data input (Odd data)
2	RxOIN0+	Positive LVDS differential data input (Odd data)
3	RxOIN1-	Negative LVDS differential data input (Odd data)
4	RxOIN1+	Positive LVDS differential data input (Odd data)
5	RxOIN2-	Negative LVDS differential data input (Odd data, DSPTMG)
6	RxOIN2+	Positive LVDS differential data input (Odd data, DSPTMG)
7	GND	Power Ground
8	RxOCLKIN-	Negative LVDS differential clock input (Odd clock)
9	RxOCLKIN+	Positive LVDS differential clock input (Odd clock)
10	RxOIN3-	Negative LVDS differential data input (Odd data)
11	RxOIN3+	Positive LVDS differential data input (Odd data)
12	RxEIN0-	Negative LVDS differential data input (Even data)
13	RxEIN0+	Positive LVDS differential data input (Even data)
14	GND	Power Ground
15	RxEIN1-	Negative LVDS differential data input (Even data)
16	RxEIN1+	Positive LVDS differential data input (Even data)
17	GND	Power Ground
18	RxEIN2-	Negative LVDS differential data input (Even data)
19	RxEIN2+	Positive LVDS differential data input (Even data)
20	RxECLKIN-	Negative LVDS differential clock input (Even clock)
21	RxECLKIN+	Positive LVDS differential clock input (Even clock)
22	RxEIN3-	Negative LVDS differential data input (Even data)
23	RxEIN3+	Positive LVDS differential data input (Even data)
24	GND	Power Ground
25	GND	Power Ground
26	GND	Power Ground
27	GND	Power Ground
28	POWER	Power +5V
29	POWER	Power +5V
30	POWER	Power +5V

Note: "Power Ground" stands for 0V.

Note1: Start from left side

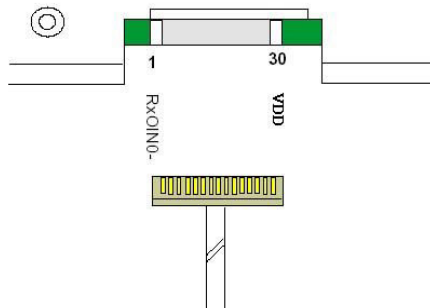
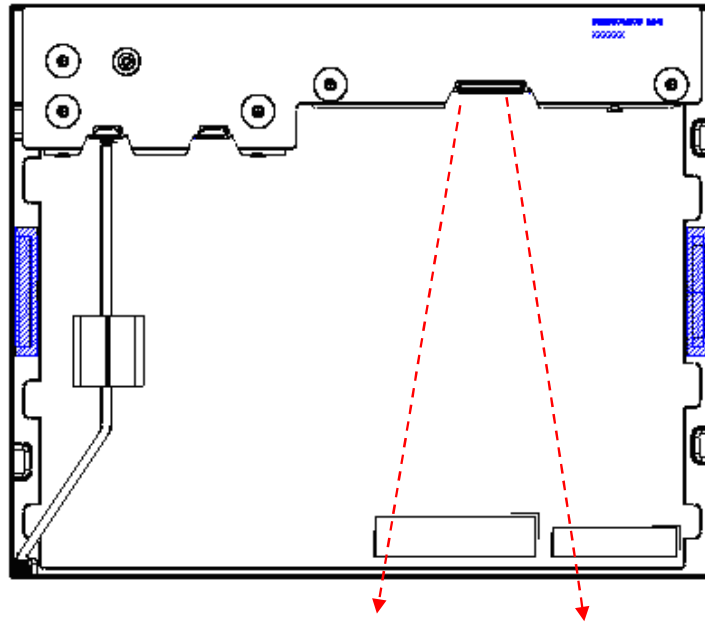

Note2: Input signals of odd and even clock shall be the same timing.

6.4 Interface Timing

6.4.1 Timing Characteristics

Signal	Item	Symbol	Min	Typ	Max	Unit
Vertical Section	Period	T_v	1032	1066	1150	Th
	Active	$T_{disp}(v)$	1024	1024	1024	Th
	Blanking	$T_{bp}(v)+T_{fp}(v)+PW_{vs}$	8	42	126	Th
Horizontal Section	Period	T_h	780	844	2047	Tclk
	Active	$T_{disp}(h)$	640	640	640	Tclk
	Blanking	$T_{bp}(h)+T_{fp}(h)+PW_{hs}$	140	204	-	Tclk
Clock	Period	T_{clk}	22.2	18.52	14.81	ns
	Frequency	Freq.	44	54	67.5	MHz
Frame Rate	Frequency	$1/T_v$	49	60	75	Hz

Note: DE mode only

6.4.2 Timing Diagram

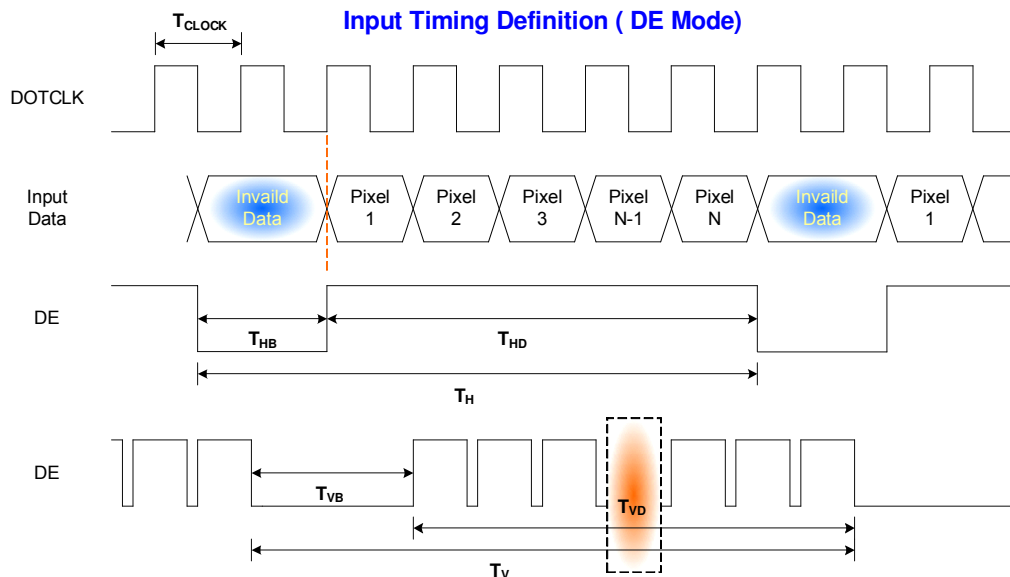

6.5 Power ON/OFF Sequence

VDD power and led on/off sequence are as follows. Interface signals are also shown in the chart. Signals from any system shall be Hi-Z state or low level when VDD is off.

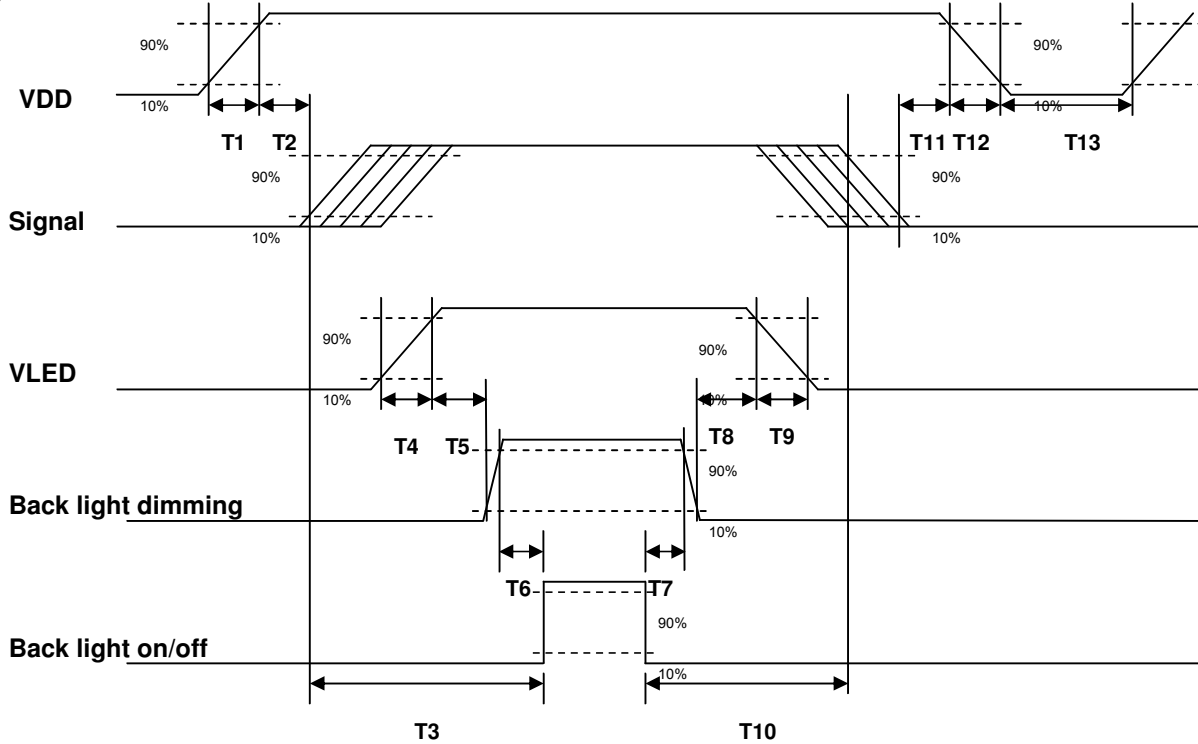

Parameter	Value			Unit
	Min.	Typ.	Max.	
T1	0.5	-	10	[ms]
T2	30	40	50	[ms]
T3	200	-	-	[ms]
T4	0.5	-	10	[ms]
T5	10	-	-	[ms]
T6	10	-	-	[ms]
T7	0	-	-	[ms]
T8	10	-	-	[ms]
T9	-	-	10	[ms]
T10	110	-	-	[ms]
T11	0	16	50	[ms]
T12	-	-	10	[ms]
T13	1000	-	-	[ms]

7. Connector and Pin Assignment

Physical interface is described as for the connector on module. These connectors are capable of accommodating the following signals and will be following components.

7.1 TFT LCD Module

7.1.1 Connector

Connector Name / Designation	Interface Connector / Interface card
Manufacturer	HRS
Type Part Number	DF14H-30P-1.25H(56)
Mating Housing Part Number	DF14-30S-1.25C

7.1.2 Pin Assignment

Pin#	Signal Name	Pin#	Signal Name
1	RxOIN0-	2	RxOIN0+
3	RxOIN1-	4	RxOIN1+
5	RxOIN2-	6	RxOIN2+
7	GND	8	RxOCLKIN-
9	RxOCLKIN+	10	RxOIN3-
11	RxOIN3+	12	RxEIN0-
13	RxEIN0+	14	GND
15	RxEIN1-	16	RxEIN1+
17	GND	18	RxEIN2-
19	RxEIN2+	20	RxECLKIN-
21	RxECLKIN+	22	RxEIN3-
23	RxEIN3+	24	GND
25	GND	26	GND
27	GND	28	POWER
29	POWER	30	POWER

7.2 Backlight Unit

Physical interface is described as for the connector on module. These connectors are capable of accommodating the following signals and will be following components.

7.2.1 Connector

Connector Name / Designation	LED Driver Board Connector
Manufacturer	JST
Type Part Number	SM08B-GHH (HF)
Mating Housing Part Number	GHR-08V-S

7.2.2 Pin Assignment

Pin#	Symbol	Description
1	VLED	12V input
2	VLED	12V input
3	VLED	12V input
4	GND	GND
5	GND	GND
6	GND	GND
7	On/OFF	3.3-5V:ON, 0V:OFF
8	Dimming	PWM

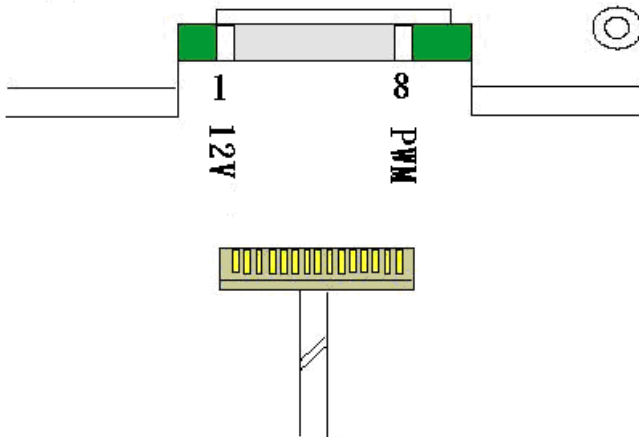

8. Reliability Test

Environment test conditions are listed as following table.

Items	Required Condition	Note
Temperature Humidity Bias (THB)	Ta= 50°C , 80%RH, 240hours	
High Temperature Operation (HTO)	Ta= 85°C , 240hours	1
Low Temperature Operation (LTO)	Ta= -30°C , 240hours	1
High Temperature Storage (HTS)	Ta= 85°C , 240hours	1
Low Temperature Storage (LTS)	Ta= -30°C , 240hours	1
Vibration Test (Non-operation)	Acceleration: 1.5 G Wave: Random Frequency: 10 - 200 - 10 Hz Sweep: 30 Minutes each Axis (X, Y, Z)	
Shock Test (Non-operation)	Acceleration: 50 G Wave: Half-sine Active Time: 20 ms Direction: ±X, ±Y, ±Z (one time for each Axis) Axis)	
Drop Test	Height: 61 cm, package test	
Thermal Shock Test (TST)	-20°C/30min, 60°C/30min, 50 cycles	
ESD (Electro-Static Discharge)	Contact Discharge: ± 8KV, 150pF(330Ω) 1sec, 8 points, 25 times/ point.	2
	Air Discharge: ± 15KV, 150pF(330Ω) 1sec, 8 points, 25 times/ point.	

Note1: No function failure occurs.

Note2: According to EN61000-4-2, ESD class B: Some performance degradation allowed. No data lost Self-recoverable. No hardware failures.

Note3:

- Water condensation is not allowed for each test items.
- Each test is done by new TFT-LCD module. Don't use the same TFT-LCD module repeatedly for reliability test.
- The reliability test is performed only to examine the TFT-LCD module capability.
- To inspect TFT-LCD module after reliability test, please store it at room temperature and room humidity for 24 hours at least in advance.
- Mura shall be ignored after high temperature reliability test.

9. Label and Packing

9.1. Shipping Label

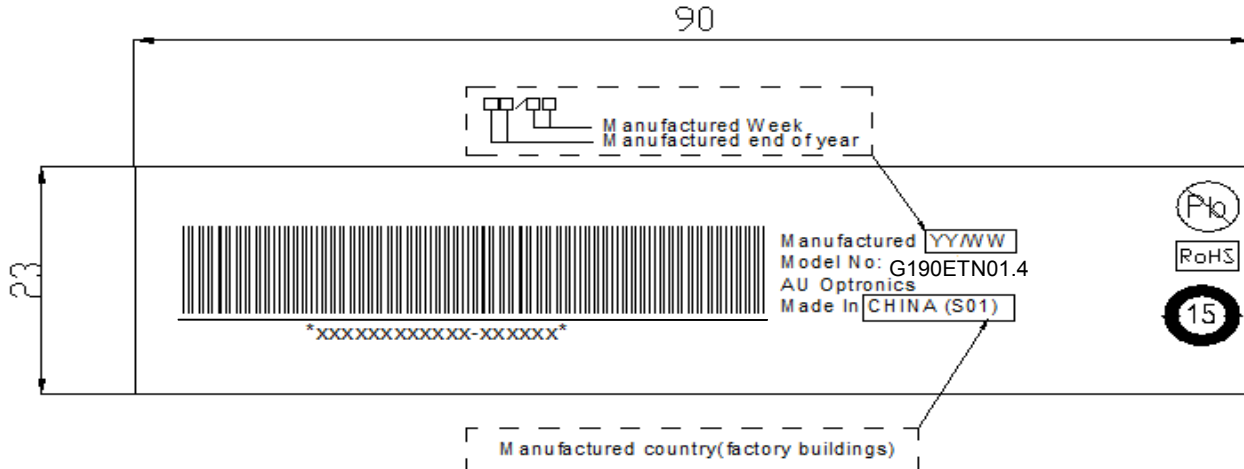

9.2 Packing Form

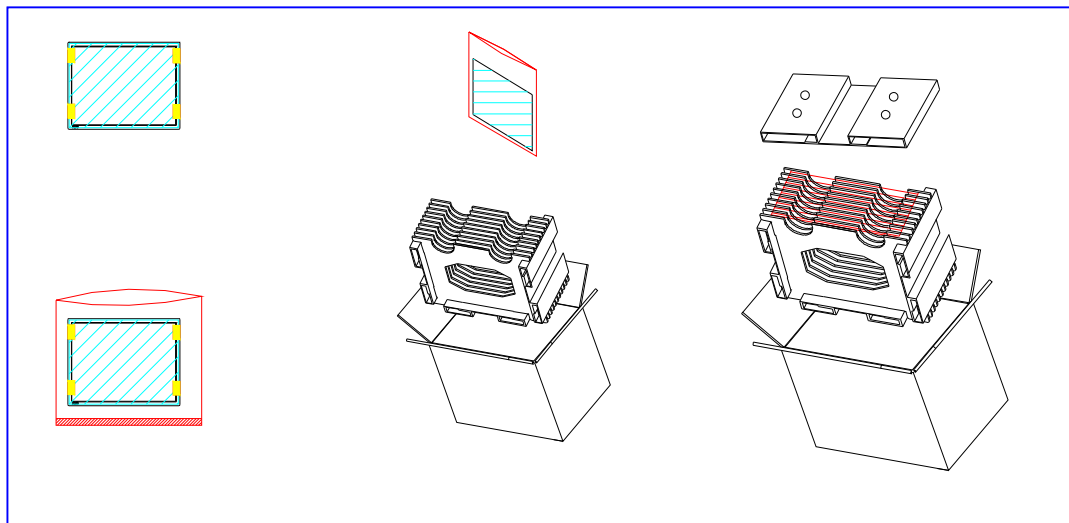

Max capacity : 9 TFT-LCD module per carton

Max weight: 19.0 kg per carton

Outside dimension of carton: 489mm(L)* 293mm(W)*420mm(H)

Pallet size : 1180 mm * 1010 mm * 135mm

9.3 Palletizing Sequence

Module by air : (2 *4) *3 layers , one pallet put 24 boxes , total 216pcs module

Module by sea : One pallet (2 *4) *3 layers + One pallet (2 *4) *1 layers , total 288pcs module

Module by sea_ HQ : One pallet (2 *4) *3 layers + One pallet (2 *4) *2 layers , Total 360 pcs module

	SHIPPING BY AIR	SHIPPING BY SEA	SHIPPING BY SEA_HQ
MODULE/CARTON	9	9	9
CARTON/LAYER	8	8	8
LAYER/PALLET	3	3+1	3+2
MODULE/PALLET	216	288	360
CARTON SIZE(MM)	489(L)*293(W)*420(H)	489(L)*293(W)*420(H)	489(L)*293(W)*420(H)
PALLET SIZE(MM)	1180(L)*1010(W)*138(H)	1180(L)*1010(W)*138(H)	1180(L)*1010(W)*138(H)
TOTAL PALLET HEIGHT(MM)	1398	1956	2376
TOTAL PALLET WEIGHT(KG)	469	634	786

ONE PALLET SHIPMENT EXAMPLE SHIPPING BY AIR USED

TWO PALLETS SHIPMENT EXAMPLE SHIPPING BY SEA USED

TWO PALLETS SHIPMENT EXAMPLE SHIPPING BY SEA_HQ USED



10. Outline Drawing

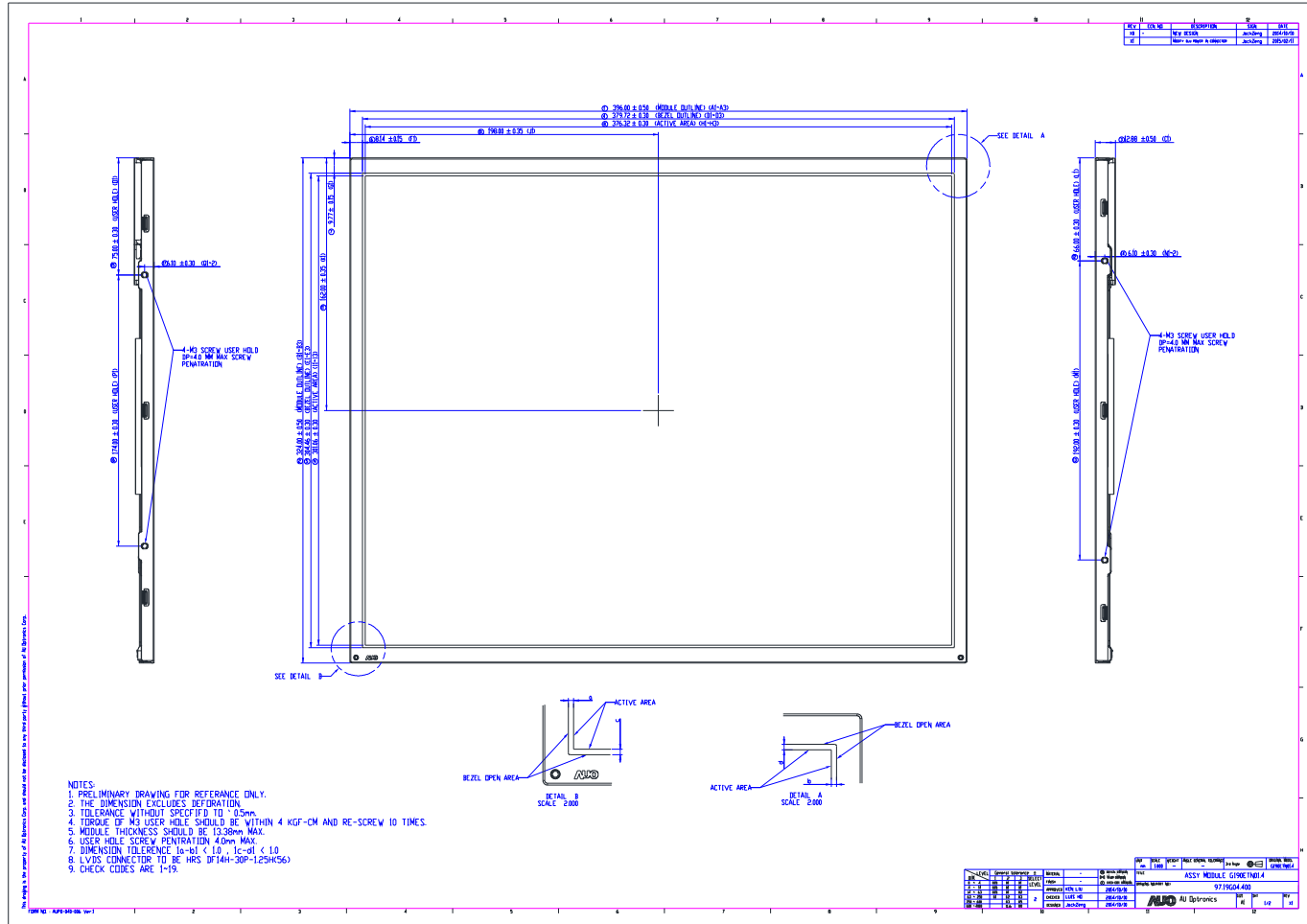



Product Specification

AU OPTRONICS CORPORATION

G190ETN01.4

