



PROPRIETARY NOTE

THIS SPECIFICATION IS THE PROPERTY OF BOE HYDIS AND SHALL NOT BE REPRODUCED OR COPIED WITHOUT THE WRITTEN PERMISSION OF BOE HYDIS AND MUST BE RETURNED TO BOE HYDIS UPON ITS REQUEST

TITLE : : HT089WX1-100
Preliminary Product Specification
Rev. P1

BOE HYDIS TECHNOLOGY

SPEC. NUMBER
S864-

PRODUCT GROUP
TFT-LCD PRODUCTS

REV.
P1

ISSUE DATE
2008. 02. 12

PAGE
1 / 27



PRODUCT GROUP

REV

ISSUE DATE

TFT-LCD PRODUCT

P1

2008.02.12

REVISION HISTORY

REV.	ECN NO.	DESCRIPTION OF CHANGES	DATE	PREPARED
P0		.Initial Release	08.01.30	Y.W.Hwang
P1		.Correct B/L power consumption from 4W to 2.7W (5,7 Page) .Update Outline Dimension (19,20 Page) . Modify Packing (23 Page)	08.02.12	Joseph Ha

SPEC. NUMBER
S864-

SPEC. TITLE
HT089WX1-100 Preliminary Product Specification

PAGE
2 / 27



PRODUCT GROUP

REV

ISSUE DATE

TFT-LCD PRODUCT

P1

2008.02.12

CONTENS

NO.	ITEM	PAGE
1.0	General Description	4
2.0	Absolute Maximum ratings	6
3.0	Electrical specifications	7
4.0	Optical specifications	8
5.0	Interface Connection	12
6.0	Signal Timing Specification	14
7.0	Signal Timing waveforms of interface signal (DE mode)	15
8.0	Input Signals, Display Colors & Gray Scale of Colors	16
9.0	Power Sequence	17
10.0	Mechanical Characteristics	18
15.0	TFT-LCD Module Outline Dimensions	19
11.0	Reliability Test	21
12.0	Handling & Cautions	22
13.0	Packing	23
14.0	Environment & Safety	24
16.0	EDID data	26

SPEC. NUMBER
S864-

SPEC. TITLE
HT089WX1-100 Preliminary Product Specification

PAGE
3 / 27



PRODUCT GROUP

REV

ISSUE DATE

TFT-LCD PRODUCT

P1

2008.02.12

1.0 GENERAL DESCRIPTION

1.1 Introduction

HT089WX1-100 is a color active matrix TFT LCD module using amorphous silicon TFT's (Thin Film Transistors) as an active switching devices. This module has a 8.9 inch diagonally measured active area with WXGA resolutions (1280 horizontal by 768 vertical pixel array). Each pixel is divided into RED, GREEN, BLUE dots which are arranged in vertical stripe and this module can display 262,144 colors. The TFT-LCD panel used for this module is a low reflection and higher color type.

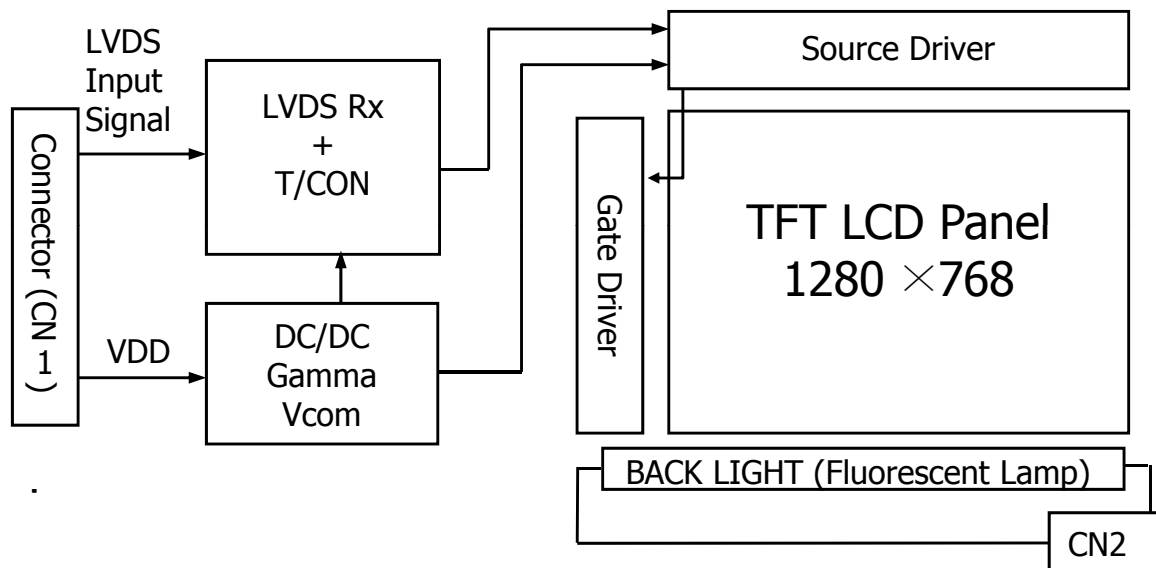

1.2 Features

- 1) Thin and light weight
- 2) 6-bit color depth, Display 262,144 colors
- 3) Low driving voltage and low power consumption
- 4) 1 Channel LVDS Interface (DE mode)
- 6) Single CCFL (Bottom side/Horizontal Direction)
- 7) SUS Bezel
- 8) Side Mounting Frame
- 9) On Board EDID chip
- 10) Anti-Glare polarizer product
- 11) RoHS Product

1.3 Application

NBPC

SPEC. NUMBER
S864-

SPEC. TITLE
HT089WX1-100 Preliminary Product Specification

PAGE
4 / 27

**PRODUCT GROUP**

REV

ISSUE DATE

TFT-LCD PRODUCT

P1

2008.02.12

1.3 General Specifications

PARAMETER	SPECIFICATION	UNIT	REMARK
Active area	193.920(H) × 116.352(V)	mm	
Number of pixels	1280(H) × 768(V)	pixels	
Pixel pitch	0.1515(H) × 0.1515(V)	mm	
Pixel arrangement	RGB Vertical stripe		
Display colors	262,144	colors	
Display mode	Normally White		
Dimensional outline	206.0 ± 0.4 (W) x 133.0 ± 0.4 (V) Thickness : 5.7 (D / Max)	mm	At PCB side
Luminance of White	200 Typ.	nit	5 Points
Weight	180 Typ. / 185 Max.	g	
Power Consumption	P _{Total} : 4.0 Typ. P _{EBL} : T.B.D	W	
Back-light	Bottom edge side 1-CCFL type (Cold Cathode Fluorescent Lamp)		
Surface treatment	Anti-Glare, 3H		

SPEC. NUMBER
S864-SPEC. TITLE
HT089WX1-100 Preliminary Product SpecificationPAGE
5 / 27



PRODUCT GROUP

REV

ISSUE DATE

TFT-LCD PRODUCT

P1

2008.02.12

2.0 ABSOLUTE MAXIMUM RATINGS

The followings are maximum values which, if exceed, may cause faulty operation or damage to the unit.

PARAMETER	SYMBOL	MIN.	MAX.	UNIT	REMARK
Logic Power Supply	V_{DD}	VSS-0.3	4.0	V	Ta = 25 ± 2 °C
Logic Input Voltage	V_{IN}	VSS-0.3	$V_{DD}+0.3$	V	
Back-light Lamp Current	I_{BL}	2.0	7.0	mA	
Back-light Frequency	F_L	45	80	KHz	
Operating Temperature	T_{OP}	0	+50	°C	Note 1
Storage Temperature	T_{ST}	-20	+60	°C	

Note 1. Temperature and relative humidity range are shown in the figure below.

- 90 [%] RH Max. ($40^{\circ}C \geq Ta$)
- Maximum wet-bulb temperature at 39 °C or less. ($Ta > 40^{\circ}C$) No condensation

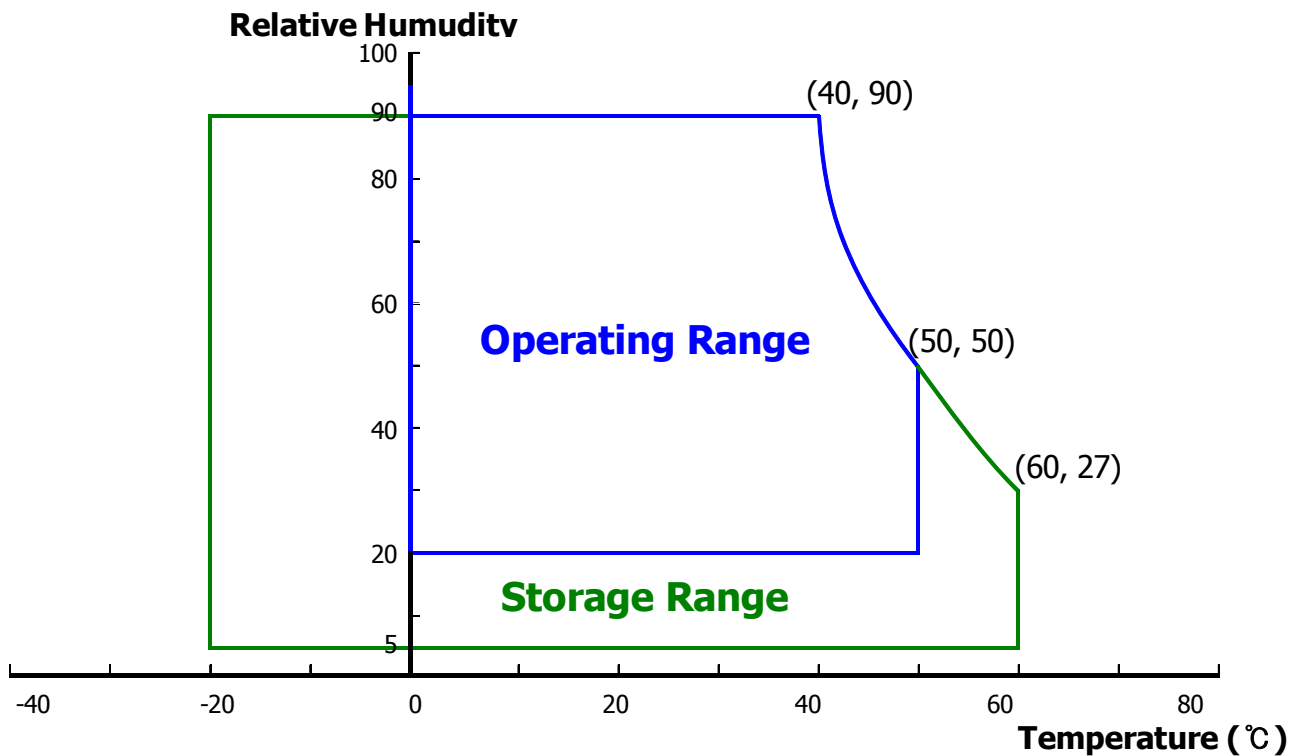



PRODUCT GROUP

REV

ISSUE DATE

TFT-LCD PRODUCT

P1

2008.02.12

3.0 ELECTRICAL SPECIFICATIONS

Ta = 25±2°C

PARAMETER		MIN.	TYP.	MAX.	UNIT	REMARK
Power Supply Voltage	V _{DD}	3.0	3.3	3.6	V	Note 1
Power Supply Current	I _{DD}	-	394	-	mA	Note 1
CCFL Ignition Time	t	-	-	1	Sec	
High Level Differential Input Signal Voltage	V _{IH}	-	-	+100	mV	
Low Level Differential Input Signal Voltage	V _{IL}	-100	-	-	mV	
Back-light Lamp Voltage	V _{BL}		450		V _{rms}	Note 2
Back-light Lamp Current	I _{BL}	2.0	6.0	7.0	mA _{rm}	
Back-light Lamp operating Frequency	F _L	45	55	80	KHz	One Lamp, Note 3
Lamp Start Voltage		-	-	880	V _{rms}	Ta = 25°C, Note 4
		-	-	1100	V _{rms}	Ta = 0°C, Note 4
Lamp Life		12,000	-	-	hrs	I _{BL} =6.0mA, Note 5
Power Consumption	P _D	-	1.3	-	W	Note 1
	P _{BL}	-	2.7	-	W	I _{BL} = 6.0mA, Note 6
	P _{Total}	-	4.0	-	W	
EBL	PEBL	-	T.B.D	-	W	At 60nit, Note 1

- Notes :
- The supply voltage is measured and specified at the interface connector of LCM.
The current draw and power consumption specified is for 3.3V at 25°C.
a) Typ. : Windows XP desktop Pattern b) Max. : Skip Sub Pixel c) EBL : Mosaic pattern (32 x 32)
 - Reference value, which is measured with Samsung Electric SIC-180 Inverter.
(VBL Min is value at IBL Min and VBL Max is value at IBL Max)
 - The lamp frequency should be selected as different as possible from the horizontal synchronous frequency and its harmonics to avoid interference which may cause line flow on the display.
 - For starting the backlight unit, the output voltage of DC/AC's transformer should be larger than the minimum lamp starting voltage. (1120 Vrms at 25 °C & 1,350 Vrms at 0 °C)
If an inverter has shutdown function it should keep its output for more than 1 second even if the lamp connector open. Otherwise the lamps may not to be turned on.
 - End of Life shall be determined by the time when any of the following is satisfied under continuous lighting at 25°C and IBL = 6.0mA.
 - Intensity drops to 50% of the Initial Value.
 - Calculated value for reference (VBL × IBL)

SPEC. NUMBER
S864-

SPEC. TITLE
HT089WX1-100 Preliminary Product Specification

PAGE
7 / 27



PRODUCT GROUP

REV

ISSUE DATE

TFT-LCD PRODUCT

P1

2008.02.12

4.0 OPTICAL SPECIFICATION

The test of Optical specifications shall be measured in a dark room (ambient luminance ≤ 1 lux and temperature = $25 \pm 2^\circ\text{C}$) with the equipment of Luminance meter system (Goniometer system and TOPCONE BM-5) and test unit shall be located at an approximate distance 50cm from the LCD surface at a viewing angle of θ and Φ equal to 0° . We refer to $\theta_{\phi=0}$ ($=\theta_3$) as the 3 o'clock direction (the "right"), $\theta_{\phi=90}$ ($=\theta_{12}$) as the 12 o'clock direction ("upward"), $\theta_{\phi=180}$ ($=\theta_9$) as the 9 o'clock direction ("left") and $\theta_{\phi=270}$ ($=\theta_6$) as the 6 o'clock direction ("bottom"). While scanning θ and/or Φ , the center of the measuring spot on the Display surface shall stay fixed. The backlight should be operating for 30 minutes prior to measurement... VDD shall be $3.3 \pm 0.3\text{V}$ at 25°C . Optimum viewing angle direction is 6 o'clock.

PARAMETER		SYMBOL	CONDITION	MIN.	TYP.	MAX.	UNIT	REMARK
Viewing Angle Range	Horizontal	θ_3	CR > 10	30	-	-	Deg.	Note 1
		θ_9		30	-	-	Deg.	
	Vertical	θ_{12}		10	-	-	Deg.	
		θ_6		20	-	-	Deg.	
Luminance Contrast ratio		CR	$\theta = 0^\circ$	300	400	-		Note 2
Luminance of White	5 Points	Y_w	$\theta = 0^\circ$ IBL = 6mA	170	200	-	cd/m ²	Note 3
White Luminance Uniformity	5 Points	ΔY_5		80	85	-	%	Note 4
	13 Points	ΔY_{13}		60	70	-		
White Chromaticity		x_w	$\theta = 0^\circ$	-	0.313	-		
		y_w		-	0.329	-		
Reproduction of Color	Red	x_R	$\theta = 0^\circ$	-	T.B.D	-		Note 5
		y_R		-	T.B.D	-		
	Green	x_G		-	T.B.D	-		
		y_G		-	T.B.D	-		
	Blue	x_B		-	T.B.D	-		
		y_B		-	T.B.D	-		
Response Time		$T_r + T_d$	Ta = 25°C $\theta = 0^\circ$	-	16	-	ms	Note 6
Cross Talk		CT	$\theta = 0^\circ$	-	-	2.0	%	Note 7

SPEC. NUMBER
S864-

SPEC. TITLE
HT089WX1-100 Preliminary Product Specification

PAGE
8 / 27



PRODUCT GROUP

REV

ISSUE DATE

TFT-LCD PRODUCT

P1

2008.02.12

- Note :
1. Viewing angle is the angle at which the contrast ratio is greater than 10. The viewing are determined for the horizontal or 3, 9 o'clock direction and the vertical or 6, 12 o'clock direction with respect to the optical axis which is normal to the LCD surface . (see FIGURE 1)
 2. Contrast measurements shall be made at viewing angle of $\Theta = 0^\circ$ and at the center of the LCD surface. Luminance shall be measured with all pixels in the view field set first to white, then to the dark (black) state. (See FIGURE 1)
Luminance Contrast Ratio (CR) is defined mathematically.

$$CR = \frac{\text{Luminance when displaying a white raster}}{\text{Luminance when displaying a black raster}}$$

3. Center Luminance of white is defined as luminance values of 5 point average across the LCD surface. Luminance shall be measured with all pixels in the view field set first to white. This measurement shall be taken at the locations shown in FIGURE 2 for a total of the measurements per display.
4. The White luminance uniformity on LCD surface is then expressed. (See FIGURE 2)

$$\text{Uniformity } \Delta Y = \frac{\text{Minimum Luminance of 5(or 13) points}}{\text{Maximum Luminance of 5(or 13) points}} \times 100 (\%)$$

5. The color chromaticity coordinates specified in Table 4 shall be calculated from the spectral data measured with all pixels first in red, green, blue and white. Measurements shall be made at the center of the panel.
6. The electro-optical response time measurements shall be made as FIGURE 3 by switching the "data" input signal OFF and ON. The times needed for the luminance to change from 10% to 90% is T_r , and 90% to 10% is T_d .
7. Cross-Talk of one area of the LCD surface by another shall be measured by comparing the luminance (YA) of a 25mm diameter area, with all display pixels set to a gray level, to the luminance (YB) of that same area when any adjacent area is driven dark. (See FIGURE 4).

SPEC. NUMBER
S864-

SPEC. TITLE
HT089WX1-100 Preliminary Product Specification

PAGE
9 / 27



Figure 1. Measurement Set Up

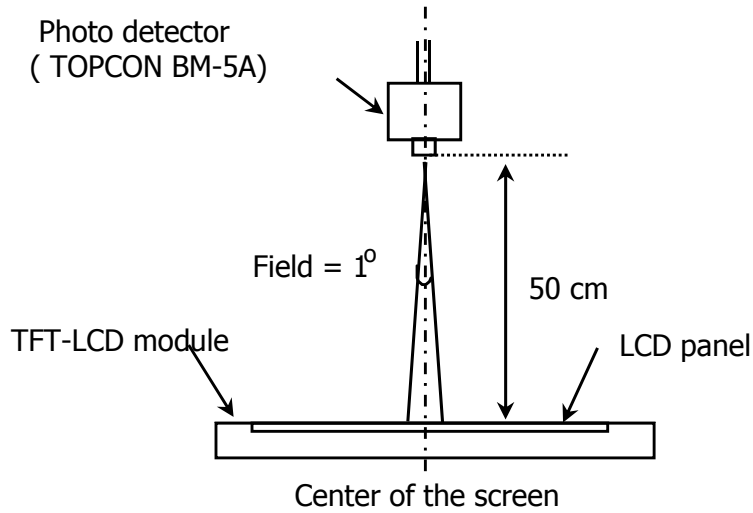
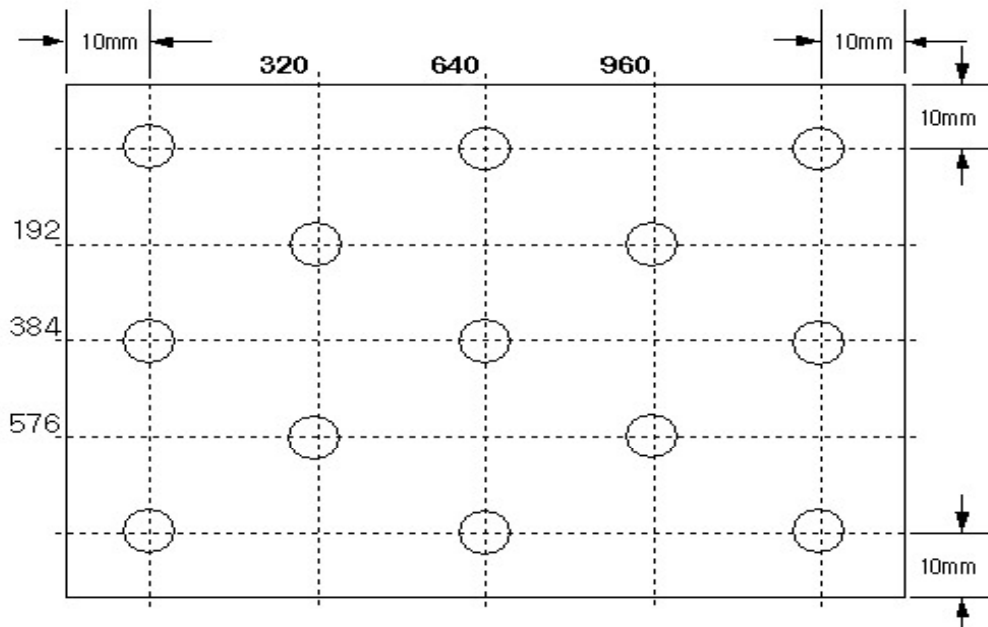

Figure 2. Average Luminance Measurement Locations & Uniformity Measurement Locations





PRODUCT GROUP

REV

ISSUE DATE

TFT-LCD PRODUCT

P1

2008.02.12

Figure 3. Response Time Testing

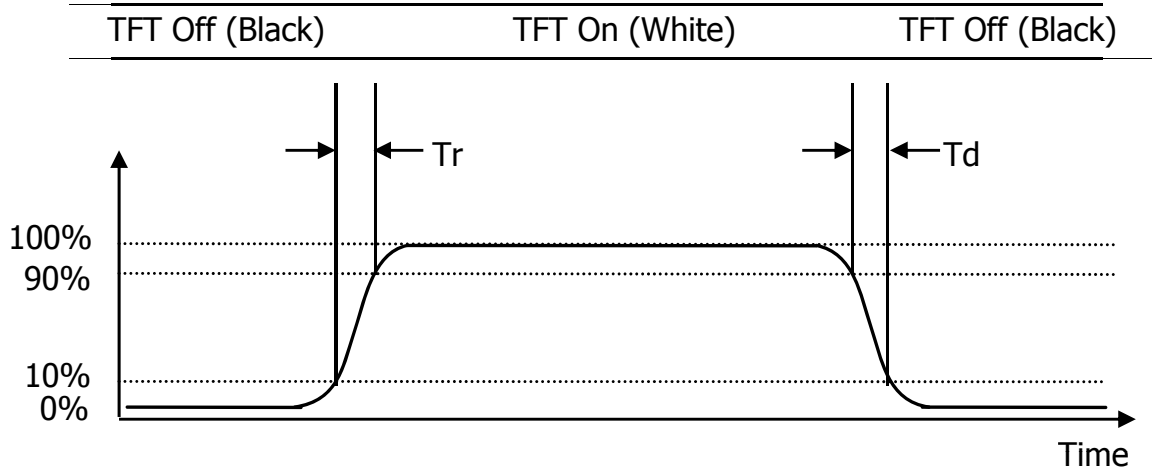
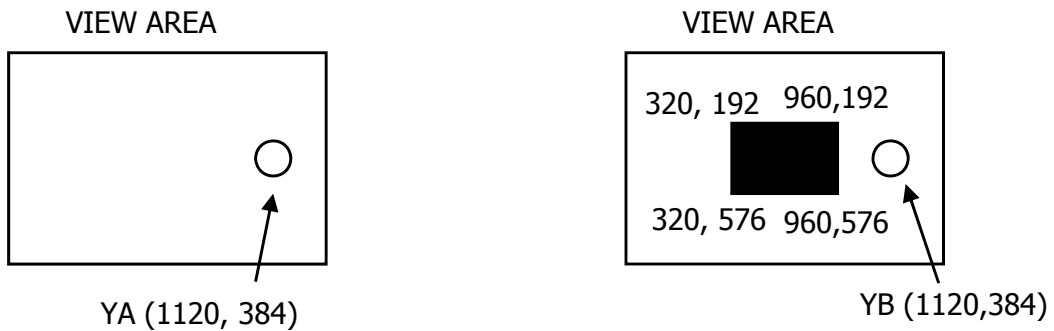

Figure 4. Cross Modulation Test Description



$$\text{Cross-Talk} = \frac{Y_B - Y_A}{Y_A} \times 100$$

Where: Y_A = Initial luminance of measured area (cd/m²)

Y_B = Subsequent luminance of measured area (cd/m²)

The location measured will be exactly the same in both patterns.



PRODUCT GROUP

REV

ISSUE DATE

TFT-LCD PRODUCT

P1

2008.02.12

5.0 INTERFACE CONNECTION

5.1 Electrical Interface

CN1	Interface Connector	20347-340E-02 (I-PEX) or compatible
	User side Connector	20345-040T-31 (I-PEX) or compatible

PIN NO.	SYMBOL	FUNCTION	PIN NO.	SYMBOL	FUNCTION
1	BIST/CT1	Built In Self Test (Connector Test)	21	NC	No Connection
2	VDD	Power Supply (3.3V typ.)	22	NC	No Connection
3	VDD	Power Supply (3.3V typ.)	23	NC	No Connection
4	V _{EDID}	DDC 3.3V power	24	NC	No Connection
5	CLK _{EDID}	DDC clock / SMBus clock	25	NC	No Connection
6	DATA _{EDID}	DDC data / SMBus data	26	NC	No Connection
7	Rin0-	- LVDS differential data input (R0-R5, G0)	27	NC	No Connection
8	Rn0+	+ LVDS differential data input (R0-R5, G0)	28	NC	No Connection
9	VSS	Ground	29	NC	No Connection
10	Rin1-	- LVDS differential data input (G1-G5, B0-B1)	30	VSS	Ground
11	Rn1+	+ LVDS differential data input (G1-G5, B0-B1)	31	VSS	Ground
12	VSS	Ground	32	VSS	Ground
13	Rin2-	- LVDS differential data input (B2-B5, HS, VS, DE)	33	VSS	Ground
14	Rn2+	+ LVDS differential data input (B2-B5, HS, VS, DE)	34	NC	No Connection
15	VSS	Ground	35	NC	No Connection
16	ClKIN-	- LVDS differential clock input	36	NC	No Connection
17	ClKIN+	+ LVDS differential clock input	37	NC	No Connection
18	VSS	Ground	38	NC	No Connection
19	NC	No Connection	39	NC	No Connection
20	NC	No Connection	40	BIST/CT2	Built In Self Test (Connector Test)

5.2 Back-light Interface

CN1	Interface Connector	BHSR-02VS-1 (JST) or equivalent
	User side Connector	SM02B-BHSS-1 (JST) or equivalent

PIN NO.	INPUT	FUNCTION	REMARK
1	HOT	High voltage	Pink
2	COLD	Ground	White

SPEC. NUMBER
S864-

SPEC. TITLE
HT089WX1-100 Preliminary Product Specification

PAGE
12 / 27



PRODUCT GROUP

REV

ISSUE DATE

TFT-LCD PRODUCT

P1

2008.02.12

5.3 LVDS Interface

LVDS Transmitter : THC63LVDM83A or equivalent

INPUT SIGNAL	TRANSMITTER		INTERFACE		DF19KR-20P-1H	REMARK
	PIN NO.	PIN NO.	SYSTEM (Tx)	TFT-LCD (Rx)	PIN NO.	
R0	51	48 47	OUT0- OUT0+	IN0- IN0+	7 8	
R1	52					
R2	54					
R3	55					
R4	56					
R5	3					
G0	4	46 45	OUT1- OUT1+	IN1- IN1+	10 11	
G1	6					
G2	7					
G3	11					
G4	12					
G5	14					
B0	15	42 41	OUT2- OUT2+	IN2- IN2+	13 14	
B1	19					
B2	20					
B3	22					
B4	23					
B5	24					
HSYNC	27	40	CLKOUT-	CLKIN-	16	
VSYNC	28					
DE	30					
MCLK	31	39	CLKOUT+	CLKIN+	17	

5.4 Data Input Format

Display position of input data

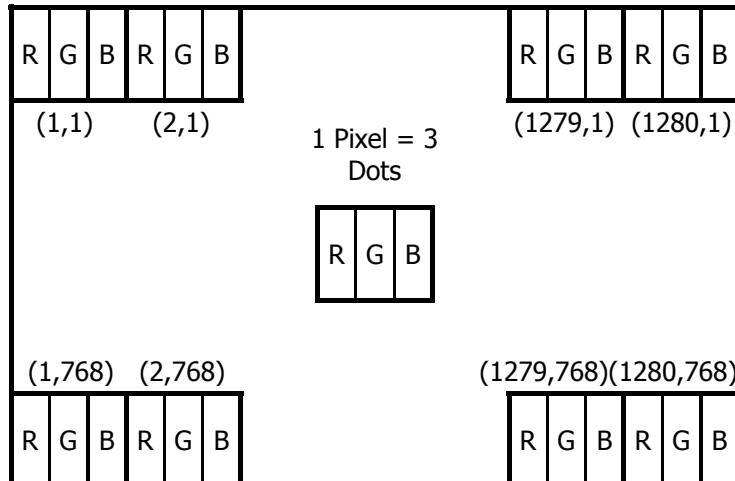

SPEC. NUMBER
S864-

SPEC. TITLE
HT089WX1-100 Preliminary Product Specification

PAGE
13 / 27



PRODUCT GROUP

REV

ISSUE DATE

TFT-LCD PRODUCT

P1

2008.02.12

6.0 SIGNAL TIMING SPECIFICATION

6.1 LVDS Transmitter Input

The 8.9" WXGA LCM is operated by the only DE (Data enable) mode.

ITEM	SYMBOL	MIN	TYP	MAX	UNIT
Frame Period	T1	-	790	-	lines
Vertical Display Period	T2	-	768	-	lines
One Line Scanning Period	T3	1350	1440	-	clocks
Horizontal Display Period	T4	-	1280	-	clocks
Clock Frequency	1/T5	-	68.25	-	MHz

6.2 LVDS Rx Interface Timing Parameter

ITEM	SYMBOL	MIN	TYP	MAX	UNIT	REMARK
CLKIN Period	tRCIP	12.5	14.43	25.00	nsec	
Input Data 0	tRIP0	-0.4	0.0	+0.4	nsec	
Input Data 1	tRIP1	tRCIP/7-0.4	tRCIP/7	tRCIP/7+0.4	nsec	
Input Data 2	tRIP2	2 × tRCIP/7-0.4	2 × tRCIP/7	2 × tRCIP/7+0.4	nsec	
Input Data 3	tRIP3	3 × tRCIP/7-0.4	3 × tRCIP/7	3 × tRCIP/7+0.4	nsec	
Input Data 4	tRIP4	4 × tRCIP/7-0.4	4 × tRCIP/7	4 × tRCIP/7+0.4	nsec	
Input Data 5	tRIP5	5 × tRCIP/7-0.4	5 × tRCIP/7	5 × tRCIP/7+0.4	nsec	
Input Data 6	tRIP6	6 × tRCIP/7-0.4	6 × tRCIP/7	6 × tRCIP/7+0.4	nsec	

* Vdiff = (RINz+)-(RINz-), (RCLKIN+)-(RCLKIN-)

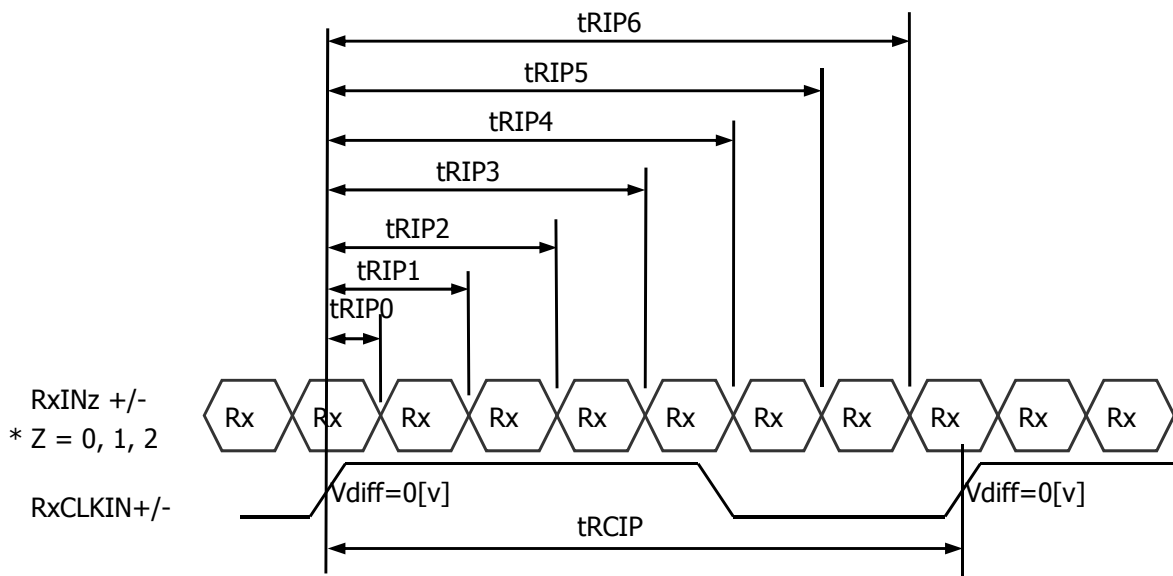

SPEC. NUMBER
S864-

SPEC. TITLE
HT089WX1-100 Preliminary Product Specification

PAGE
14 / 27



7.0 SIGNAL TIMING WAVEFORMS OF INTERFACE SIGNAL (DE MODE)

7.1 Timing Waveforms of Interface Signal

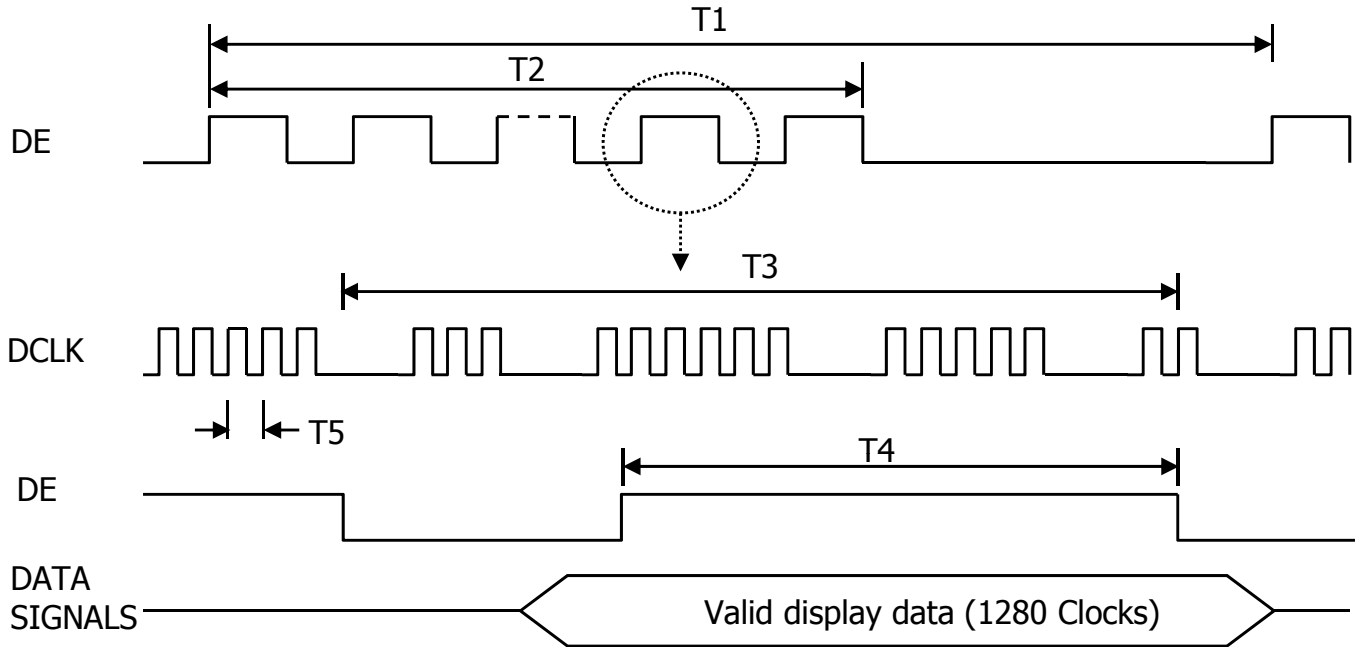



PRODUCT GROUP

REV

ISSUE DATE

TFT-LCD PRODUCT

P1

2008.02.12

8.0 INPUT SIGNALS, BASIC DISPLAY COLORS & GRAY SCALE OF COLORS

Each color is displayed in sixty-four gray scales from a 6 bit data signal input. A total of 262,144 colors are derived from the resultant 18 bit data.

Colors & Gray Scale		Red Data						Green Data						Blue Data					
		R5	R4	R3	R2	R1	R0	G5	G4	G3	G2	G1	G0	B5	B4	B3	B2	B1	B0
Basic Colors	Black	0	0	0	0	0	0	0	0	0	0	0	0	0	0	0	0	0	0
	Blue	0	0	0	0	0	0	0	0	0	0	0	0	1	1	1	1	1	1
	Green	0	0	0	0	0	0	1	1	1	1	1	1	0	0	0	0	0	0
	Cyan	0	0	0	0	0	0	1	1	1	1	1	1	1	1	1	1	1	1
	Red	1	1	1	1	1	1	0	0	0	0	0	0	0	0	0	0	0	0
	Magenta	1	1	1	1	1	1	0	0	0	0	0	0	1	1	1	1	1	1
	Yellow	1	1	1	1	1	1	1	1	1	1	1	1	0	0	0	0	0	0
	White	1	1	1	1	1	1	1	1	1	1	1	1	1	1	1	1	1	1
Gray Scale Of Red	Black	0	0	0	0	0	0	0	0	0	0	0	0	0	0	0	0	0	0
	△	0	0	0	0	0	1	0	0	0	0	0	0	0	0	0	0	0	0
	Darker	0	0	0	0	1	0	0	0	0	0	0	0	0	0	0	0	0	0
	△	↓						↓						↓					
	▽	↓						↓						↓					
	Brighter	1	1	1	1	0	1	0	0	0	0	0	0	0	0	0	0	0	0
	▽	1	1	1	1	1	0	0	0	0	0	0	0	0	0	0	0	0	0
	Red	1	1	1	1	1	1	0	0	0	0	0	0	0	0	0	0	0	0
Gray Scale Of Green	Black	0	0	0	0	0	0	0	0	0	0	0	0	0	0	0	0	0	0
	△	0	0	0	0	0	0	0	0	0	0	0	1	0	0	0	0	0	0
	Darker	0	0	0	0	0	0	0	0	0	0	1	0	0	0	0	0	0	0
	△	↓						↓						↓					
	▽	↓						↓						↓					
	Brighter	0	0	0	0	0	0	1	1	1	1	0	1	0	0	0	0	0	0
	▽	0	0	0	0	0	0	1	1	1	1	1	0	0	0	0	0	0	0
	Green	0	0	0	0	0	0	1	1	1	1	1	1	0	0	0	0	0	0
Gray Scale Of Blue	Black	0	0	0	0	0	0	0	0	0	0	0	0	0	0	0	0	0	0
	△	0	0	0	0	0	0	0	0	0	0	0	0	0	0	0	0	0	1
	Darker	0	0	0	0	0	0	0	0	0	0	0	0	0	0	0	0	1	0
	△	↓						↓						↓					
	▽	↓						↓						↓					
	Brighter	0	0	0	0	0	0	0	0	0	0	0	0	1	1	1	1	0	1
	▽	0	0	0	0	0	0	0	0	0	0	0	0	1	1	1	1	1	0
	Blue	0	0	0	0	0	0	0	0	0	0	0	0	1	1	1	1	1	1
Gray Scale Of White & Black	Black	0	0	0	0	0	0	0	0	0	0	0	0	0	0	0	0	0	0
	△	0	0	0	0	0	1	0	0	0	0	0	1	0	0	0	0	0	1
	Darker	0	0	0	0	1	0	0	0	0	0	1	0	0	0	0	0	1	0
	△	↓						↓						↓					
	▽	↓						↓						↓					
	Brighter	1	1	1	1	0	1	1	1	1	1	0	1	1	1	1	1	0	1
	▽	1	1	1	1	1	0	1	1	1	1	1	0	1	1	1	1	1	0
	White	1	1	1	1	1	1	1	1	1	1	1	1	1	1	1	1	1	1

SPEC. NUMBER
S864-

SPEC. TITLE
HT089WX1-100 Preliminary Product Specification

PAGE
16 / 27



9.0 POWER SEQUENCE

To prevent a latch-up or DC operation of the LCD module, the power on/off sequence shall be as shown in below

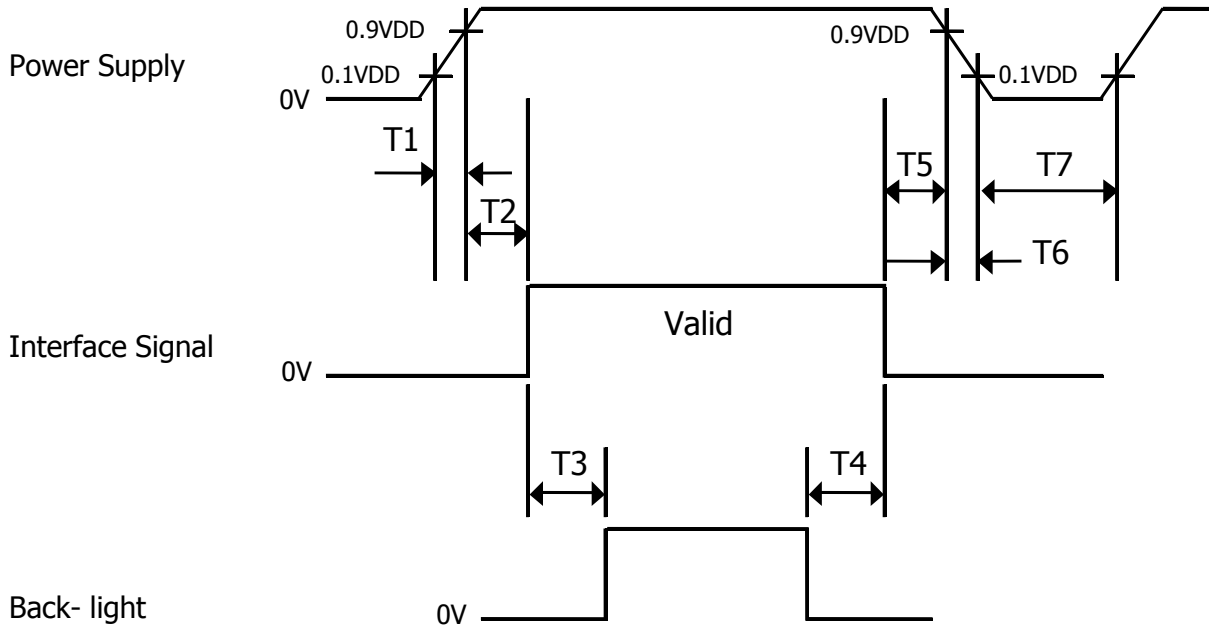

- 1) $0 < T1 \leq 10 \text{ ms}$
- 2) $0 < T2 \leq 50 \text{ ms}$
- 3) $200 \text{ ms} \leq T3$
- 4) $200 \text{ ms} \leq T4$
- 5) $0 \leq T5 \leq 50 \text{ ms}$
- 6) $0 \leq T6 \leq 10 \text{ ms}$
- 7) $500 \text{ ms} \leq T7$

Notes : 1. When the power supply VDD is 0V, Keep the level of input signals on the low or keep high impedance.
2. Do not keep the interface signal high impedance when power is on.
3. Back Light must be turn on after power for logic and interface signal are valid.



PRODUCT GROUP

REV

ISSUE DATE

TFT-LCD PRODUCT

P1

2008.02.12

10.0 MECHANICAL CHARACTERISTICS

10.1 Dimensional Requirements

FIGURE 5, 6 shown in appendix shows mechanical outlines for the model.

PARAMETER	SPECIFICATION	UNIT
Active area	193.92 (H) × 116.35 (V)	mm
Number of pixels	1280 (H) × 768 (V) (1 pixel = R + G + B dots)	pixels
Pixel pitch	0.1515 (H) × 0.1515 (V)	mm
Pixel arrangement	RGB Vertical stripe	
Display colors	262,144	colors
Display mode	Normally White	
Dimensional outline	206.0 ± 0.4 (W) x 133.0 ± 0.4 (V) x 5.7 (D / Max)	mm
Weight	185 Max.	G
Back-light	Connector : BHSR-02VS-1 CCFL, horizontal-lamp type Lamp wire Length : 25.0 ± 5.0	mm

10.2 Mounting

See FIGURE 5. (shown in Appendix)

10.3 Anti-Glare Polarizer

The surface of the LCD has an anti-glare coating to minimize reflection and a coating to reduce scratching.

10.4 Light Leakage

There shall not be visible light from the back-lighting system around the edges of the screen as seen from a distance 50 cm from the screen with an overhead light level of 150lux. The manufacture shall furnish limit samples of the panel showing the light leakage acceptable.

SPEC. NUMBER
S864-

SPEC. TITLE
HT089WX1-100 Preliminary Product Specification

PAGE
18 / 27



PRODUCT GROUP

REV

ISSUE DATE

TFT-LCD PRODUCT

P1

2008.02.12

11.0 TFT-LCD Module Outline Dimensions

11.1 Font View

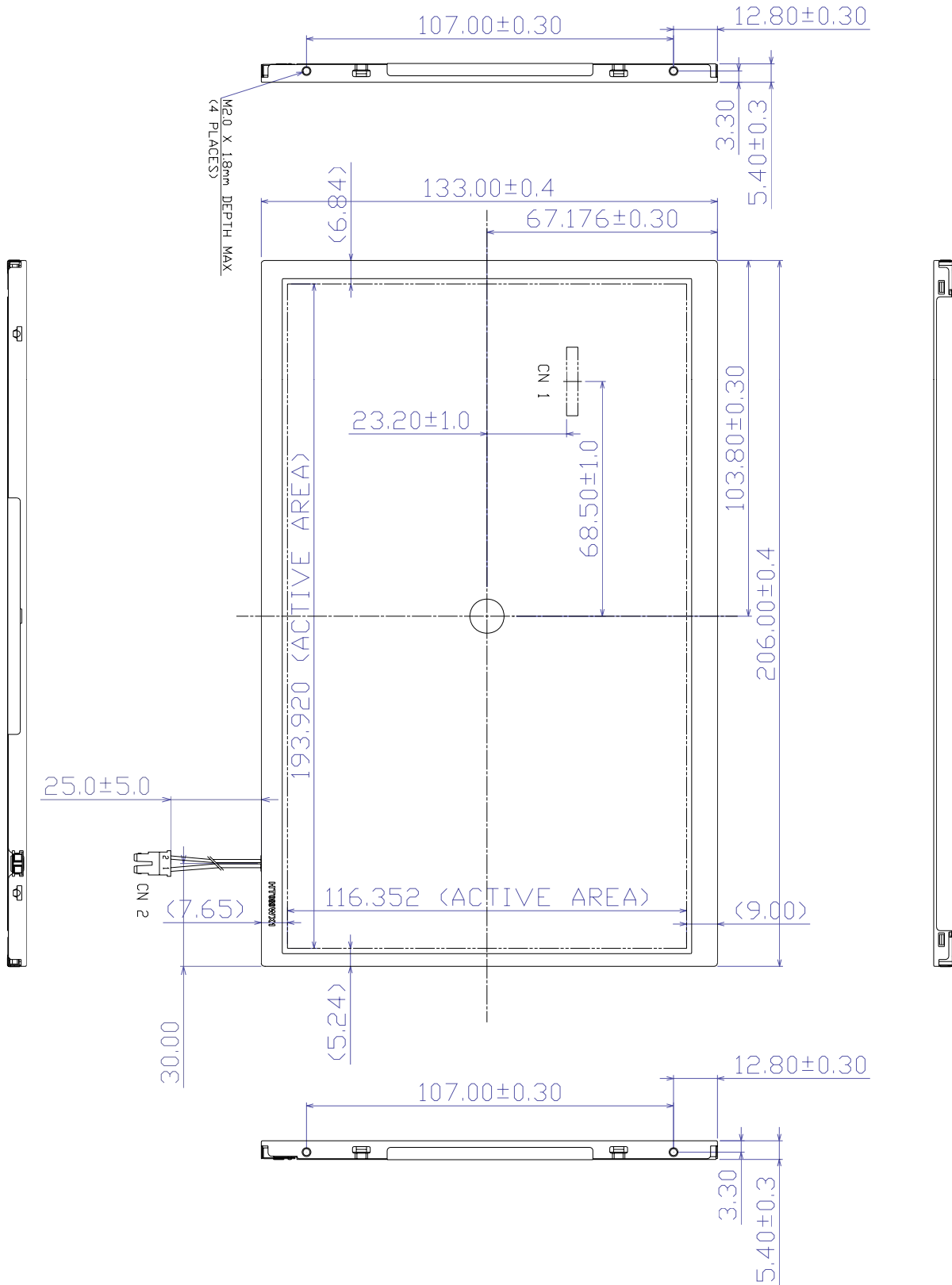

SPEC. NUMBER
S864-

SPEC. TITLE
HT089WX1-100 Preliminary Product Specification

PAGE
19 / 27



PRODUCT GROUP

REV

ISSUE DATE

TFT-LCD PRODUCT

P1

2008.02.12

11.1 Rear View

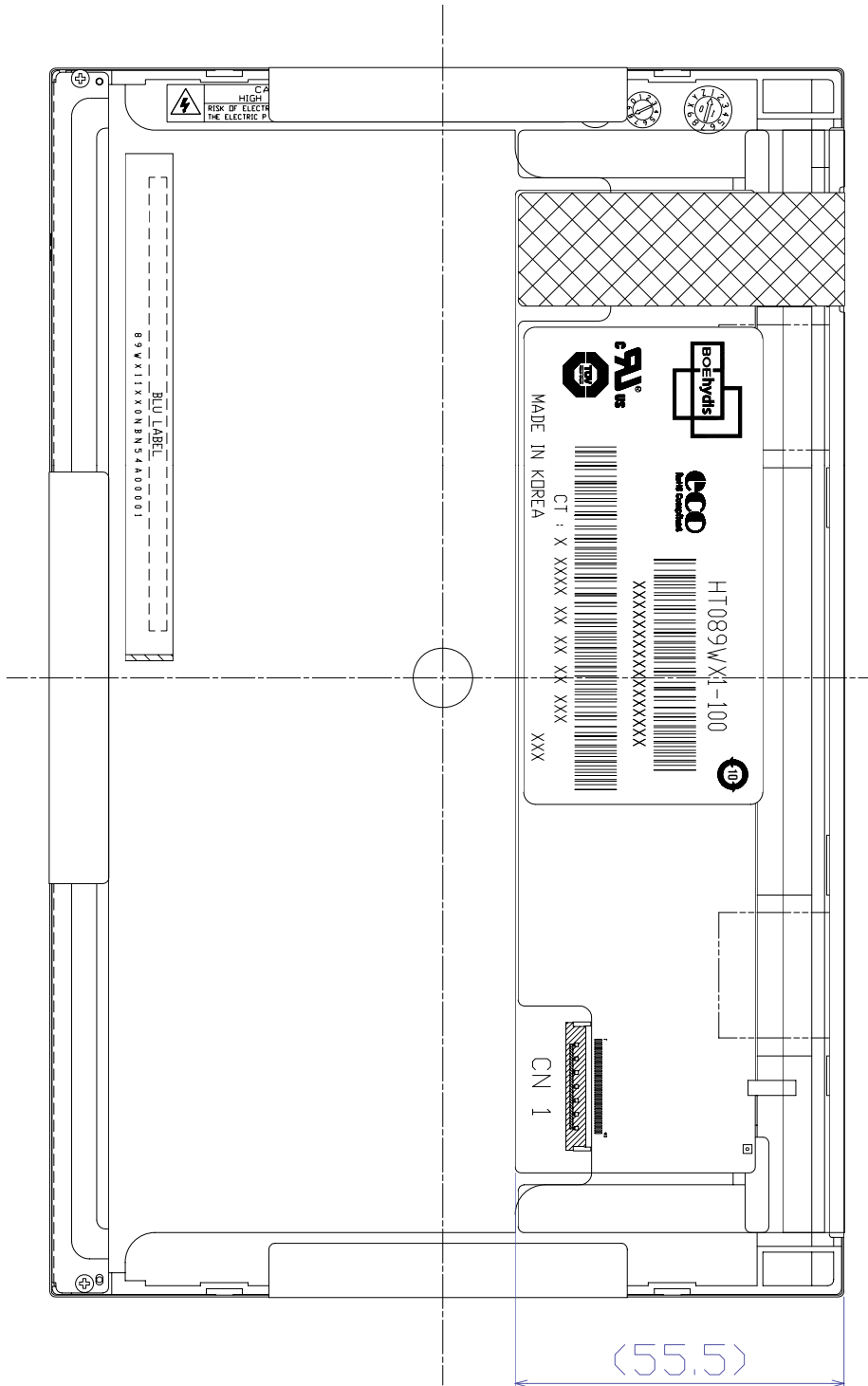

NOTE

CN 1 : (I-PEX) 20347-340E-02 (40PIN)
CN 2 : (JST) BHSR-02VS-1 (2PIN)
GENERAL TOLERANCE : ± 0.5mm

SPEC. NUMBER
S864-

SPEC. TITLE
HT089WX1-100 Preliminary Product Specification

PAGE
20 / 27



PRODUCT GROUP

REV

ISSUE DATE

TFT-LCD PRODUCT

P1

2008.02.12

12.0 RELIABILITY TEST

NO	TEST ITEM	CONDITIONS
1	High temperature storage test	Ta = 60 °C, 240 hrs
2	Low temperature storage test	Ta = -20 °C, 240 hrs
3	High temperature & high humidity operation test	Ta = 50 °C, 80%RH, 240hrs
4	High temperature operation test	Ta = 50 °C, 240 hrs
5	Low temperature operation test	Ta = 0 °C, 240 hrs
6	Thermal shock	Ta = -20 °C ↔ 60 °C (30 min), 100 cycle
7	Vibration test (non-operating)	Frequency : 10~500Hz Gravity/AMP : 1.5G Period : X,Y,Z 30min
8	Shock test (non-operating)	Gravity : 220G Pulse width : 2ms, half sine wave ±X, ±Y, ±Z Once for each direction
9	Electro-Static Discharge Test (non-operating)	Air : 150pF, 330ohm, 15KV Contact : 150pF, 330ohm, 8KV

SPEC. NUMBER
S864-

SPEC. TITLE
HT089WX1-100 Preliminary Product Specification

PAGE
21 / 27



PRODUCT GROUP

REV

ISSUE DATE

TFT-LCD PRODUCT

P1

2008.02.12

13.0 HANDLING & CAUTIONS

13.1 Cautions when taking out the module

- 1) Pick the pouch only, when taking out module from a shipping package.

13.2 Cautions for handling the module

- 1) As the electrostatic discharges may break the LCD module, handle the LCD module with care. Peel a protection sheet off from the LCD panel surface as slowly as possible.
- 2) As the LCD panel and backlight element are made from fragile glass material, impulse and pressure to the LCD module should be avoided.
- 3) As the surface of the polarizer is very soft and easily scratched, use a soft dry cloth without chemicals for cleaning.
- 4) Do not pull the interface connector in or out while the LCD module is operating.
- 5) Put the module display side down on a flat horizontal plane.
- 6) Handle connectors and cables with care.

13.3 Cautions for the operation

- 1) When the module is operating, do not lose MCLK, DE signals. If any one of these signals were lost, the LCD panel would be damaged.
- 2) Obey the supply voltage sequence. If wrong sequence were applied, the module would be damaged.

13.4 Cautions for the atmosphere

- 1) Dewdrop atmosphere should be avoided.
- 2) Do not store and/or operate the LCD module in a high temperature and/or humidity atmosphere. Storage in an electro-conductive polymer-packing pouch and under relatively low temperature atmosphere is recommended.

13.5 Cautions for the module characteristics

- 1) Do not apply fixed pattern data signal to the LCD module at product aging.
- 2) Applying fixed pattern for a long time may cause image sticking.

13.6 Other cautions

- 1) Do not disassemble and/or re-assemble LCD module.
- 2) Do not re-adjust variable resistor or switch etc.
- 3) When returning the module for repair or etc, please pack the module not to be broken.
- 4) We recommend using the original shipping packages.

SPEC. NUMBER
S864-

SPEC. TITLE
HT089WX1-100 Preliminary Product Specification

PAGE
22 / 27



PRODUCT GROUP

REV

ISSUE DATE

TFT-LCD PRODUCT

P1

2008.02.12

14.0 PACKING

14.1 Packing Order

- Notes : 1. Box Dimension: 261mm(W) X 349mm(D) X 311mm(H)
2. Package Quantity in one Box: 10pcs

Put Bottom Pad into the box.

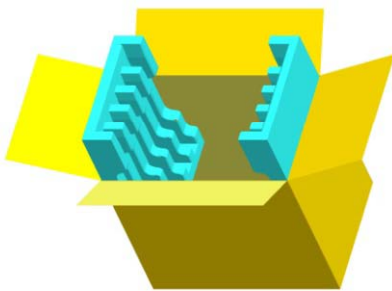

Put silica gels in the box.



After sealing the box, attach Packing Label on the attach position sign area of the box.

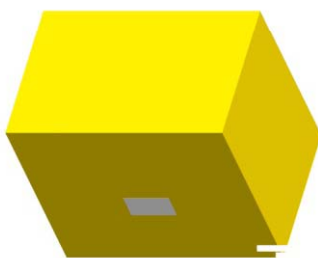

As shown in the figure, place the Modules bundled by shielding bag in the box.

Place a top pad on the top of the box.

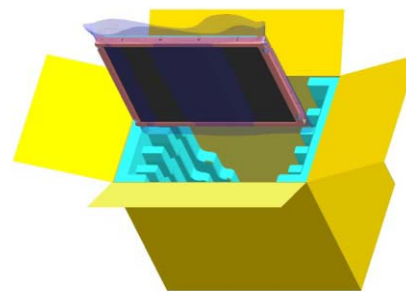

SPEC. NUMBER
S864-

SPEC. TITLE
HT089WX1-100 Preliminary Product Specification

PAGE
23 / 27



PRODUCT GROUP

REV

ISSUE DATE

TFT-LCD PRODUCT

P1

2008.02.12

15.0 Environment & Safety

15.1 Packing Label

1) Label Size: 108 mm (L) × 56 mm (W)

2) Contents

Model : HT089WX1-100

Q`ty : Module Q`ty in one box

Serial No. : Box Serial No. See next figure for detail description.

Date : Packing Date

FG Code : FG Code of Product

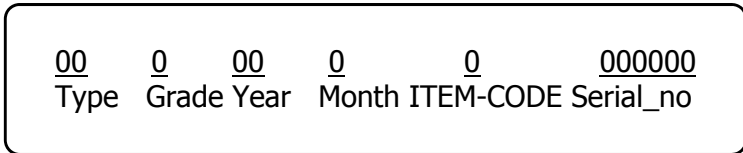
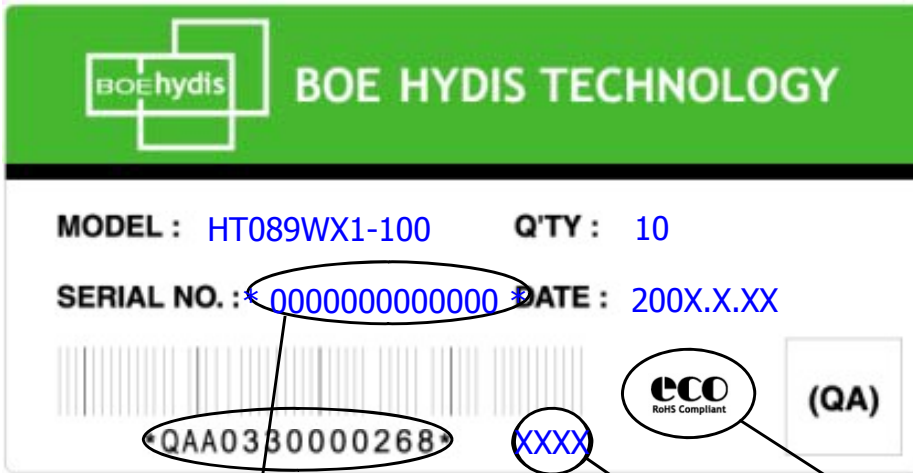

FG CODE

RoHS Mark

15.2 Mercury disposal & High voltage caution

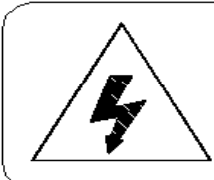

HIGH VOLTAGE
CAUTION

RISK OF ELECTRIC SHOCK,
DISCONNECT THE ELECTRIC
POWER BEFORE SERVICING

COLD CATHODE FLUORESCENT LAMP IN LCD
PANEL CONTAINS A SMALL AMOUNT
OF MERCURY. PLEASE FOLLOW LOCAL OR-
DINANCES OR REGULATIONS FOR DISPOSAL.

SPEC. NUMBER
S864-

SPEC. TITLE
HT089WX1-100 Preliminary Product Specification

PAGE
24 / 27



PRODUCT GROUP

REV

ISSUE DATE

TFT-LCD PRODUCT

P1

2008.02.12

15.3 Product Label

T.B.D

SPEC. NUMBER
S864-

SPEC. TITLE
HT089WX1-100 Preliminary Product Specification

PAGE
25 / 27



PRODUCT GROUP

REV

ISSUE DATE

TFT-LCD PRODUCT

P1

2008.02.12

16.0 EDID Data

Add	Function	Hex	Input Value	Add	Function	Hex	Input Value
00	Header	00	EDID	20	Blue y high bits	25	0.145
01		FF		21	White x high bits	50	0.313
02		FF		22	White y high bits	54	0.329
03		FF		23	Established timing 1	00	
04		FF		24	Established timing 2	00	
05		FF		25	Established timing 3	00	
06		FF		26	Standard timing #1	01	Not Used
07		00		27		01	
08	ID Manufacturer Name	09	BOE	28	Standard timing #2	01	Not Used
09		E5		29		01	
0A	ID Product Code	A4	1700	2A	Standard timing #3	01	Not Used
0B		06		2B		01	
0C	32-bit serial No.	00		2C	Standard timing #4	01	Not Used
0D		00		2D		01	
0E		00		2E	Standard timing #5	01	Not Used
0F		00		2F		01	
10	Week of manufacture	00	0	30	Standard timing #6	01	Not Used
11	Year of Manufacture	12	2008	31		01	
12	EDID Structure Ver.	01	1	32	Standard timing #7	01	Not Used
13	EDID revision #	03	3	33		01	
14	Video input definition	80		34	Standard timing #8	01	Not Used
15	Max H image size	13	19	35		01	
16	Max V image size	0B	11	36	Detailed timing / monitor descriptor #1	A9	. Main clock : 68.25MHz . Hor. Active : 1280 . Hor. Blanking : 160 . 4 bits of Hor. Active + . 4 bits of Hor. Blanking . Ver. Active : 768 . Ver. Blanking : 22 . 4 bits of Ver. Active + . 4 bits of Ver. Blanking . Hor. Sync Offset : 48 . H sync Pulse Width : 32 . V sync Offset : 3 line . V Sync Pulse width : 6 line
17	Display Gamma	78	2.2	37		1A	
18	Feature support	0A	RGB mode	38		00	
19	Red/Green low bits	F9		39		A0	
1A	Blue/White low bits	C5		3A		50	
1B	Red x high bits	96	0.589	3B		20	
1C	Red y high bits	54	0.331	3C		17	
1D	Green x high bits	4D	0.303	3D		30	
1E	Green y high bits	8A	0.540	3E	30		
1F	Blue x high bits	25	0.147	3F	20		

SPEC. NUMBER
S864-

SPEC. TITLE
HT089WX1-100 Preliminary Product Specification

PAGE
26 / 27



PRODUCT GROUP

REV

ISSUE DATE

TFT-LCD PRODUCT

P1

2008.02.12

Add	Function	Hex	Input Value	Add	Function	Hex	Input Value
40	Detailed timing / monitor descriptor #1	36	Horizontal Image Size : 193 mm (Low 8 bits) Vertical Image Size : 116 mm (Low 8 bits) 4 bits of Hor. Image Size + 4 bits of Ver. Image Size Hor. Border : 0 pixel Vertical Border : 0 line	60	Detailed timing / monitor descriptor #3	4F	Company name : BOE HYDIS
41		00		61		45	
42		C1		62		20	
43		74		63		48	
44		00		64		59	
45		00		65		44	
46		00		66		49	
47		19		67		53	
48	Detailed timing / monitor descriptor #2	00		68	Detailed timing / monitor descriptor #4	0A	Model name : HT089WX1
49		00		69		20	
4A		00		6A		20	
4B		FE		6B		20	
4C		00		6C		00	
4D		0A		6D		00	
4E		20		6E	00		
4F		20		6F	FE		
50		20		70	00		
51		20		71	48		
52		20		72	54		
53		20		73	30		
54		20		74	38		
55		20		75	39		
56		20		76	57		
57	20	77	58				
58	20	78	31				
59	20	79	20				
5A	Detailed timing / monitor descriptor #3	00		7A		20	
5B		00		7B		20	
5C		00		7C		20	
5D		FE		7D		0A	
5E		00		7E	00		
5F		42		7F	C1		

SPEC. NUMBER
S864-

SPEC. TITLE
HT089WX1-100 Preliminary Product Specification

PAGE
27 / 27