

TITLE: BA101WS2-100-3QP0**Product Specification****Rev. 0**www.jxlcd.com**BEIJING BOE OPTOELECTRONICS TECHNOLOGY**

SPEC. NUMBER

-

PRODUCT GROUP

TFT-LCD

REV.

0

ISSUE DATE

2011.07.07

PAGE

1 OF 23

Contents

No.	Items	Page
1.0	General Description	4
2.0	Absolute Maximum ratings	6
3.0	Electrical specifications.	7
4.0	Optical specifications.	8
5.0	Reliability Test	10
6.0	FPC Pin Assignment	11
7.0	APPENDIX	12
8.0	Packing (Single-Panel)	18
9.0	Handling & Cautions	19

1.0 GENERAL DESCRIPTION

1.1 Introduction

BA101WS2-100 is a color active matrix TFT LCD module using amorphous silicon TFT's (Thin Film Transistors) as an active switching devices. This module has a 10.1 inch diagonally measured active area with WSVGA resolutions (1024 horizontal by 600 vertical pixel array). Each pixel is divided into RED, GREEN, BLUE dots which are arranged in vertical stripe and this module can display 262K colors. The TFT-LCD panel used for this module is adapted for a low reflection and higher color type.

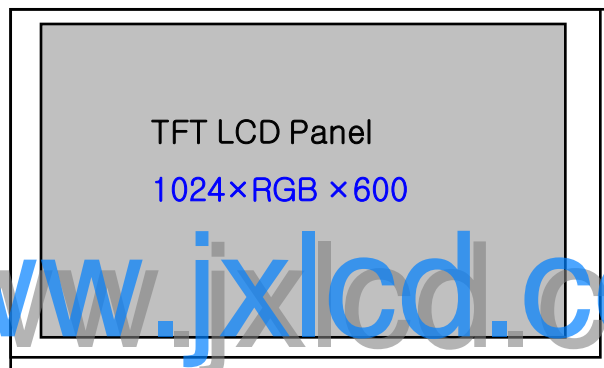

1.2 Features

- Thin and light weight
- 0.5 t Glass

1.3 Application

- Tablet & Application Mini-PC (Wide Type)

1.4 General Specification

< Table 1. General Specifications >

Parameter	Specification	Unit	Remarks
Active area	222.72(H) × 125.28(V)	mm	
PNL outline	226.7(H) × 131.8(V)	mm	
Number of pixels	1024(H) × 600(V)	pixels	
Pixel pitch	0.2175 (H) × 0.2083 (V) × RGB	mm	
Pixel arrangement	Pixels RGB stripe arrangement		
Display colors	262K	colors	
Color gamut (C light)	50	%	
Display mode	Normally White		
Panel Size	230.4(H) × 134.2(V)	mm	
Weight	TBD	g	
View direction	6:00 O'clock		Figure 9

2.0 ABSOLUTE MAXIMUM RATINGS

The followings are maximum values which, if exceed, may cause faulty operation or damage to the unit. The operational and non-operational maximum voltage and current values are listed in Table 2.

< Table 2. LCD Module Electrical Specifications > [Ta =25±2 °C]

Parameter	Symbol	Min.	Max.	Unit	Remarks
LC operating Voltage	V _{OP}		4	V	Ta=25+/-2°C
Operating Temperature (Humidity)	T _{OP}	0	+50	°C	
Storage Temperature (Humidity)	T _{ST}	-20	+60	°C	

*1) Liquid Crystal driving voltage

Due to the characteristics of LC Material, this voltage varies with environmental temperature

3.0 ELECTRICAL SPECIFICATIONS

3.1 Electrical Specifications

< Table 3. LCD Module Electrical Specifications >

[Ta =25±2 °C]

Parameter	Symbol	Value	Unit	Remarks
TFT Gate ON Voltage	VGH	21	V	
TFT Gate OFF Voltage	VGL	-8.0	V	
TFT Common Electrode Voltage	VCOM	3.8	V	
Analog Power Supply Voltage	AVDD	10.4	V	

www.jxlcd.com

4.0 OPTICAL SPECIFICATION

4.1 Overview

The test of Optical specifications shall be measured in a dark room (ambient luminance $\leq 1\text{lux}$ and temperature = $25\pm 2^\circ\text{C}$) with the equipment of Luminance meter system (Goniometer system and TOPCON BM-5) and test unit shall be located at an approximate distance 50cm from the LCD surface at a viewing angle of θ and Φ equal to 0° . We refer to $\theta\Phi=0$ ($=\theta_3$) as the 3 o'clock direction (the "right"), $\theta\Phi=90$ ($=\theta_{12}$) as the 12 o'clock direction ("upward"), $\theta\Phi=180$ ($=\theta_9$) as the 9 o'clock direction ("left") and $\theta\Phi=270$ ($=\theta_6$) as the 6 o'clock direction ("bottom"). While scanning θ and /or Φ , the center of the measuring spot on the Display surface shall stay fixed. The backlight should be operating for 30 minutes prior to measurement. VDD shall be $3.3\pm 0.3\text{V}$ at 25°C . Optimum viewing angle direction is 6 'clock.

4.2 Optical Specifications

<Table 5. Optical Specifications>

Parameter		Symbol	Condition	Min.	Typ.	Max.	Unit	Remark
Viewing Angle range	Horizontal	Θ_3	CR > 10	-	70	-	Deg.	Note 1 WV-Pol
		Θ_9		-	70	-	Deg.	
	Vertical	Θ_{12}		-	60	-	Deg.	
		Θ_6		-	70	-	Deg.	
Color Gamut (C light)				50		%	Note 2	
Luminance Contrast ratio		CR	$\Theta = 0^\circ$		600			
Transmittance		T(%)	$\Theta = 0^\circ$	-	6.6	-	%	Base on C Light Note 3
White Chromaticity		X_w	$\Theta = 0^\circ$	0.245	0.295	0.345		Note 4 CF Glass
		Y_w		0.281	0.331	0.381		
Reproduction of color (C light)	Red	X_R	$\Theta = 0^\circ$	0.58	0.63	0.68		
		Y_R		0.26	0.31	0.36		
	Green	X_G		0.244	0.294	0.344		
		Y_G		0.468	0.518	0.568		
	Blue	X_B		0.093	0.143	0.193		
		Y_B		0.101	0.151	0.201		
Response Time (Rising + Falling)		T_{RT}	Ta = 25°C $\Theta = 0^\circ$	-	8	-	ms	Note 5

Notes : 1. Viewing angle is the angle at which the contrast ratio is greater than 10. The viewing angles are determined for the horizontal or 3, 9 o'clock direction and the vertical or 6, 12 o'clock direction with respect to the optical axis which is normal to the LCD surface (see FIGURE 1).

2. Contrast measurements shall be made at viewing angle of $\Theta = 0$ and at the center of the LCD surface. Luminance shall be measured with all pixels in the view field set first to white, then to the dark (black) state. (see FIGURE 1) Luminance Contrast Ratio (CR) is defined mathematically.

$$CR = \frac{\text{Luminance when displaying a white raster}}{\text{Luminance when displaying a black raster}}$$

3. Transmittance is the Value with Polarizer

4. The color chromaticity coordinates specified in Table 5 shall be calculated from the spectral data measured with all pixels first in red, green, blue and white. Measurements shall be made at the center of the panel.

5. The electro-optical response time measurements shall be made as FIGURE 3 by switching the "data" input signal ON and OFF. The times needed for the luminance to change from 10% to 90% is T_r , and 90% to 10% is T_d .

5.0 RELIABILITY TEST

<Table 6. Reliability test>

No	Test Items	Conditions
1	High temperature storage test	Ta = 80 °C, 240 hrs
2	Low temperature storage test	Ta = -30 °C, 240 hrs
3	High temperature operation test	Ta = 70 °C, 240 hrs
4	Low temperature operation test	Ta = -20 °C, 240 hrs
5	High temperature & high humidity operation test	Ta = 60 °C, 90%RH, 240 hrs
6	Thermal shock	Ta = -30°C~ 80°C, 100Cycle, per 30min

www.jxlcd.com

6.0 FPC Pin Assignment

6.1 FPC PIN Assignment

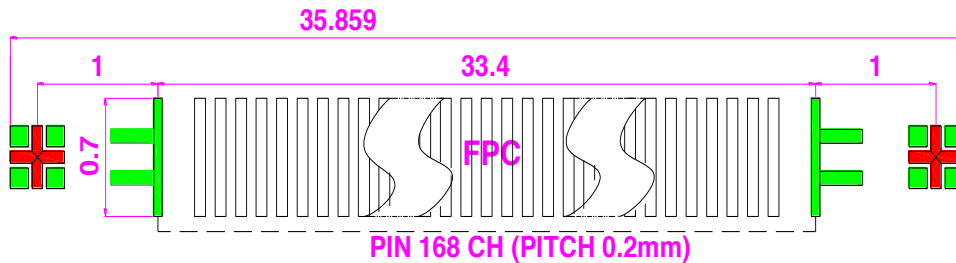

Notes:

CF is in Upper side

TFT is in Bottom side

1	DUMMY	31	VDD	61	V13	91	D21	121	VDD	151	AGND
2	DUMMY	32	VDD	62	V12	92	DASHD	122	VDD	152	VCOM
3	GND	33	DUMMY	63	V11	93	D22	123	SCL	153	VCOM
4	GND	34	DUMMY	64	V10	94	D23	124	SDA	154	VCOM
5	VGL	35	DUMMY	65	V9	95	DASHD	125	CSB	155	VGH
6	VCOM	36	DUMMY	66	V8	96	D24	126	SEL1	156	VGH
7	VCOM	37	DUMMY	67	GAML	97	D25	127	SELO	157	VGH
8	VCOM	38	RES[2]	68	D00	98	DASHD	128	FRAME	158	VEE
9	COM2_IN	39	UPDN	69	D01	99	D26	129	DUMMY	159	VEE
10	VCOM	40	SHLR	70	D02	100	D27	130	DUMMY	160	VEE
11	DRV1 -B	41	GRB	71	D03	101	GND LVDS	131	HFRC	161	VDD
12	DRV1	42	STBYB	72	D04	102	GND LVDS	132	DITHER	162	VDD
13	DRVH	43	DCLKPOL	73	D05	103	DEN	133	DIMO	163	VDD
14	DRVA	44	RES[1]	74	D06	104	DASHD	134	PINCTL	164	VSS
15	AVDDG	45	DUMMY	75	D07	105	HSD	135	NBW	165	VSS
16	FBA	46	BIST	76	D10	106	VSD	136	DIMI	166	VSS
17	FBH	47	IFSEL	77	D11	107	GAMH	137	DUMMY	167	DUMMY
18	FBL	48	MODE	78	D12	108	V7	138	DUMMY	168	DUMMY
19	PWR-EN	49	OPDRV	79	D13	109	V6	139	DUMMY		
20	VCOMI	50	CABC EN1	80	D14	110	V5	140	DUMMY		
21	DUMMY	51	CABC EN0	81	D15	111	V4	141	DUMMY		
22	AGDNH	52	VDD	82	D16	112	V3	142	DUMMY		
23	AGDNH	53	VDD	83	D17	113	V2	143	DUMMY		
24	DUMMY	54	GND	84	REV	114	V1	144	VDD		
25	AVDDL	55	GND	85	VDD LVDS	115	AGNDH	145	VDD		
26	AVDDL	56	AVDD	86	VDD LVDS	116	AGNDH	146	GND		
27	DUMMY	57	AVDD	87	NINC	117	AVDDL	147	GND		
28	GND	58	AGND	88	DCLK	118	AVDDL	148	AVDD		
29	GND	59	AGND	89	DASHD	119	GND	149	AVDD		
30	DUMMY	60	V14	90	D20	120	GND	150	AGND		

<Figure 1. FPC Pad Dimension & FPC Pin Assignment>

7.0 APPENDIX

Figure 2. The Definition of V_{th} & V_{sat}

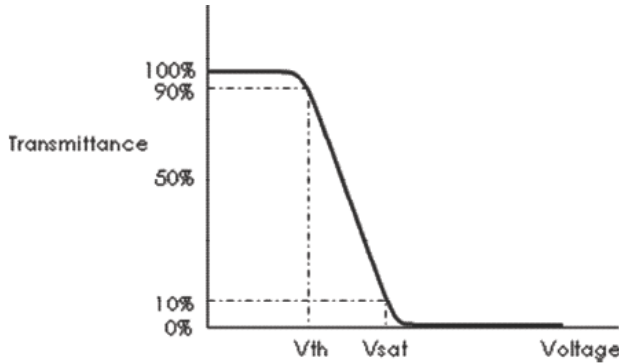

Figure 3. Measurement Set Up

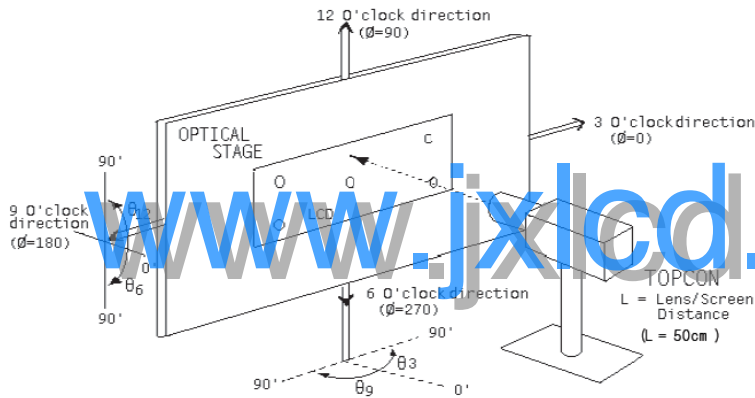

Figure 4. Response Time Testing

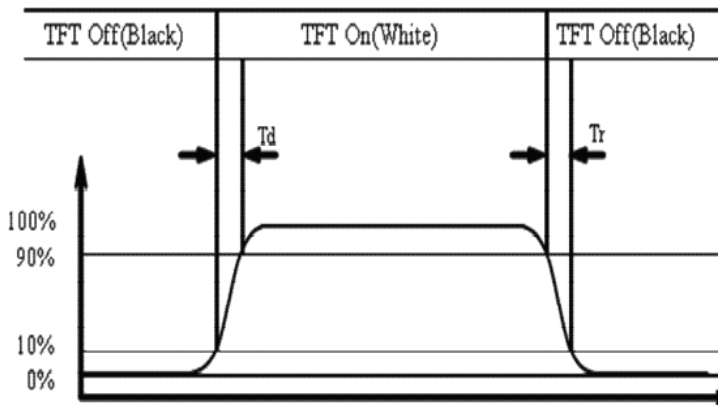

Figure 5. TFT-LCD Panel Outline Dimension

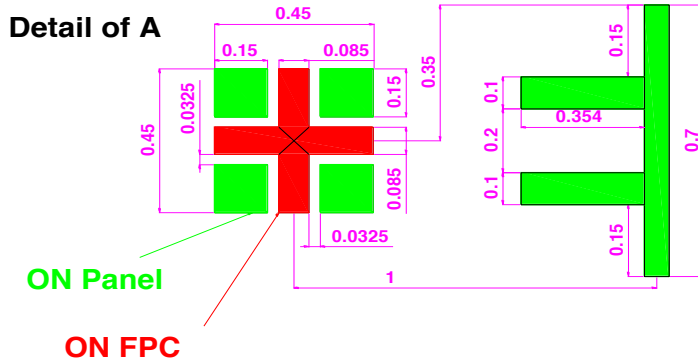
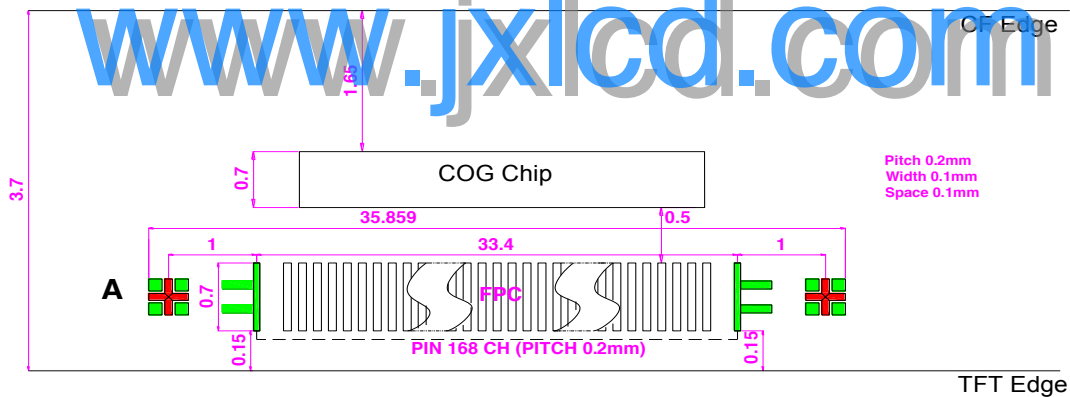
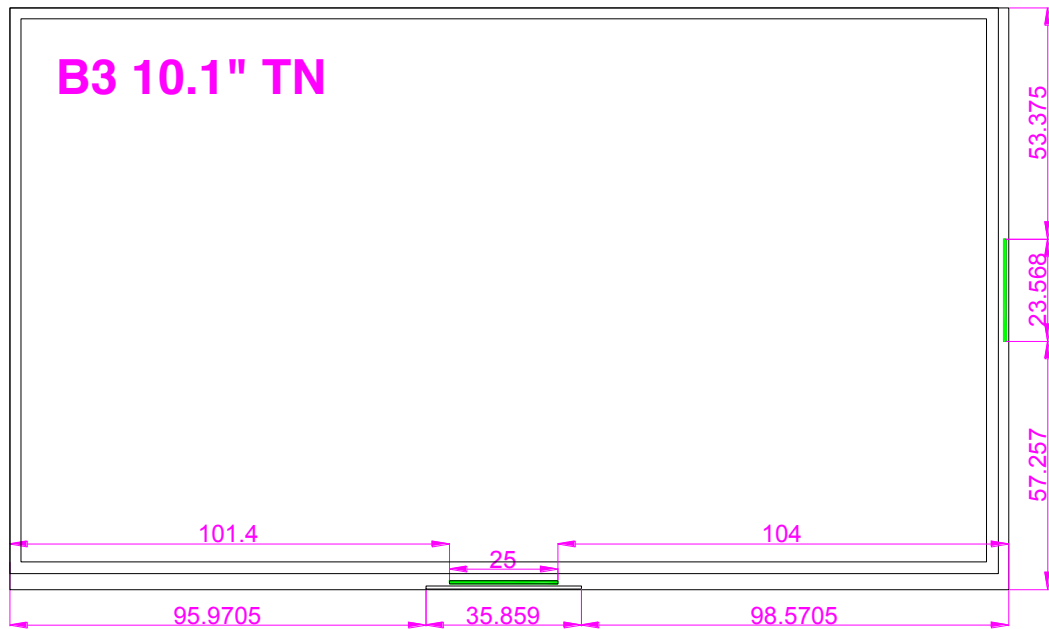

Figure 6. TFT-LCD Panel Test

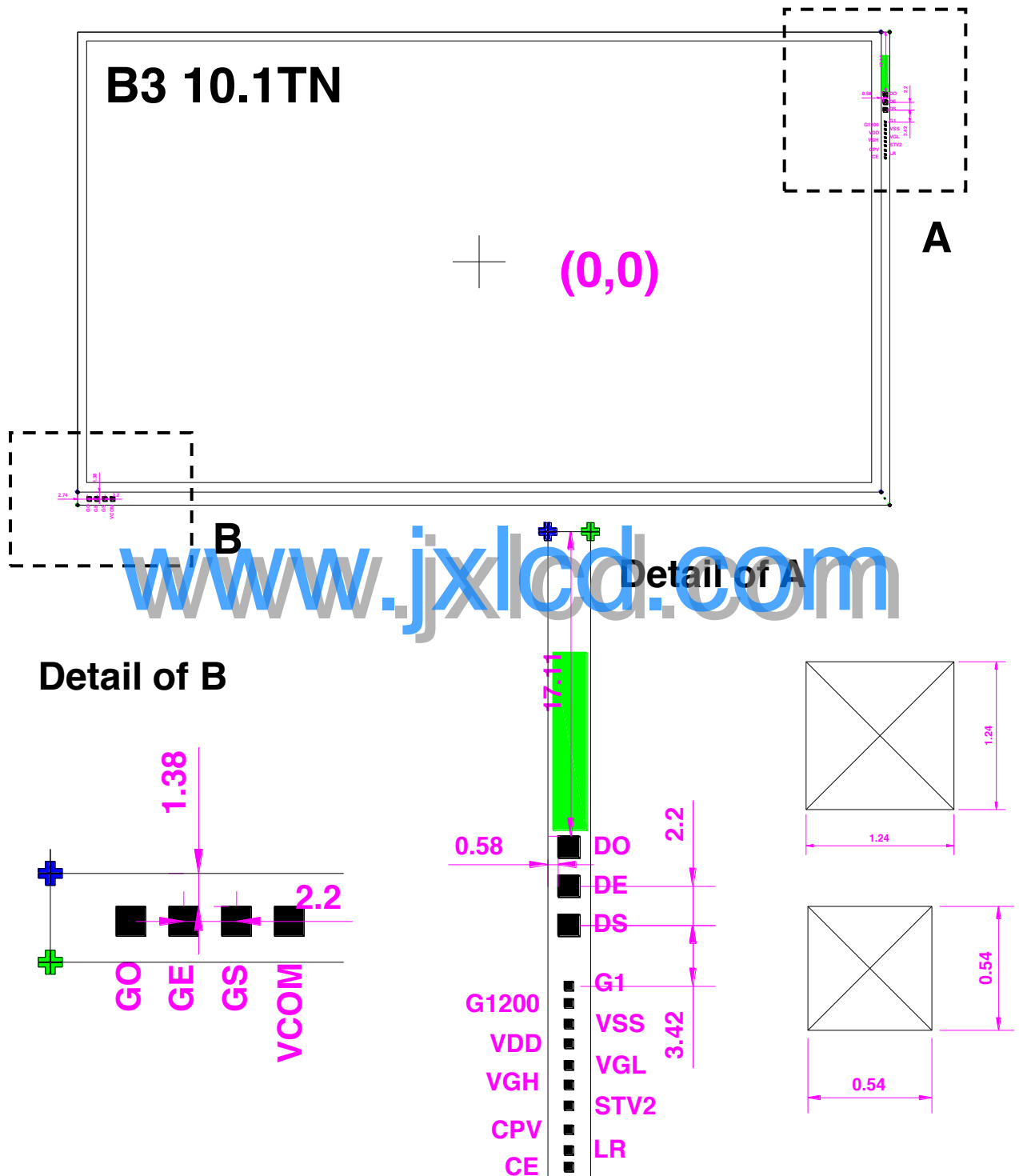

Figure 7. TFT-LCD Q Panel outline dimension

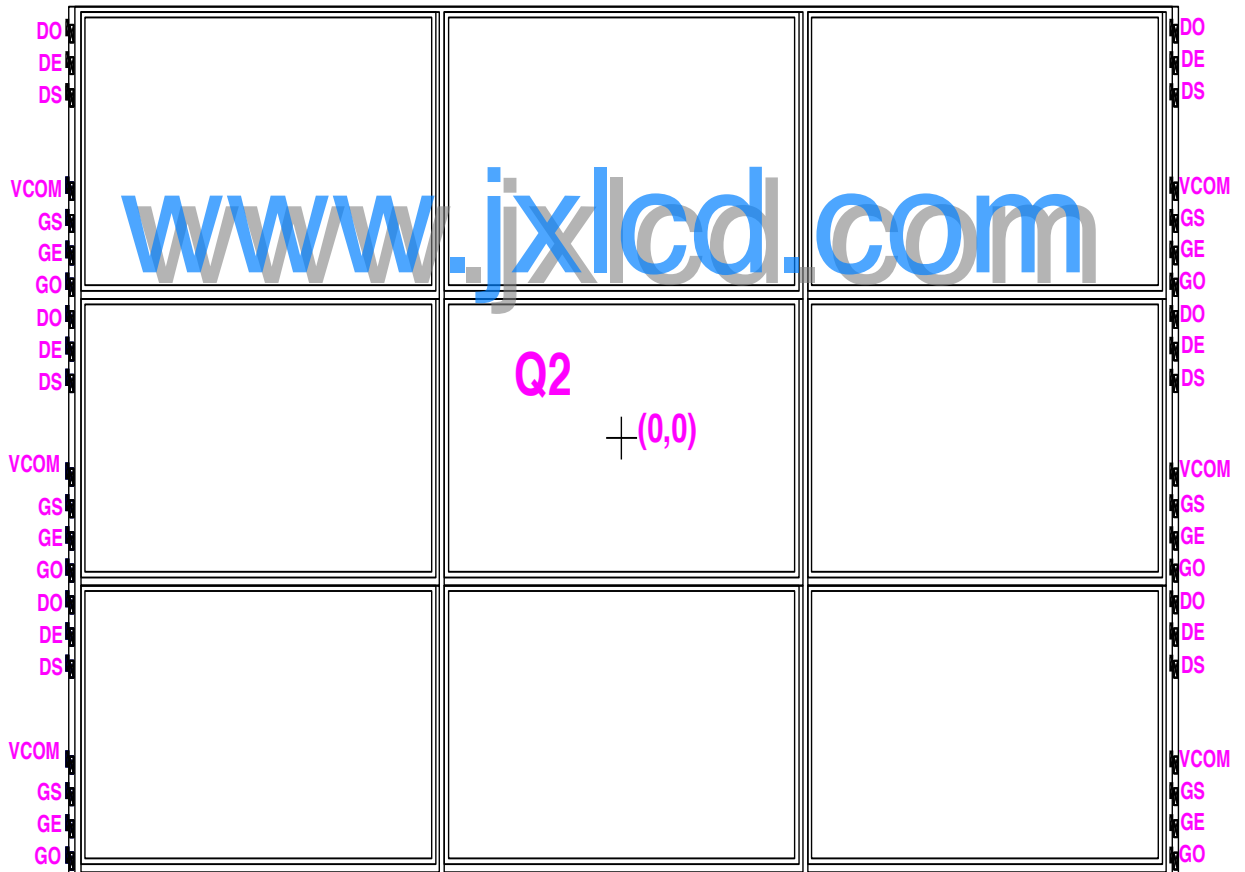
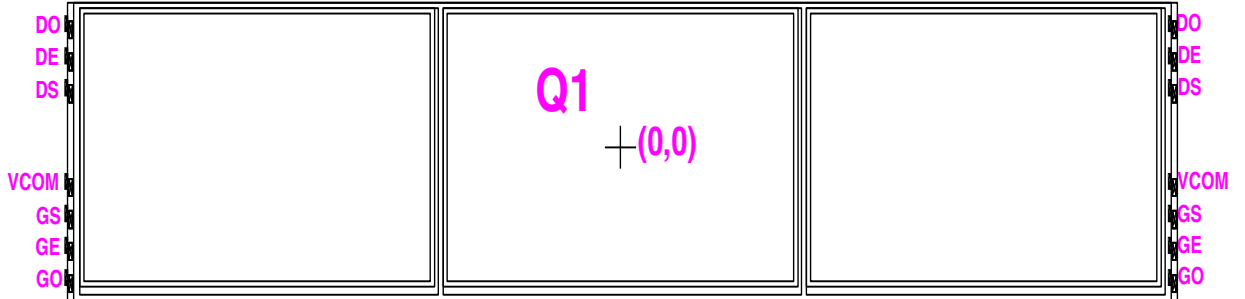
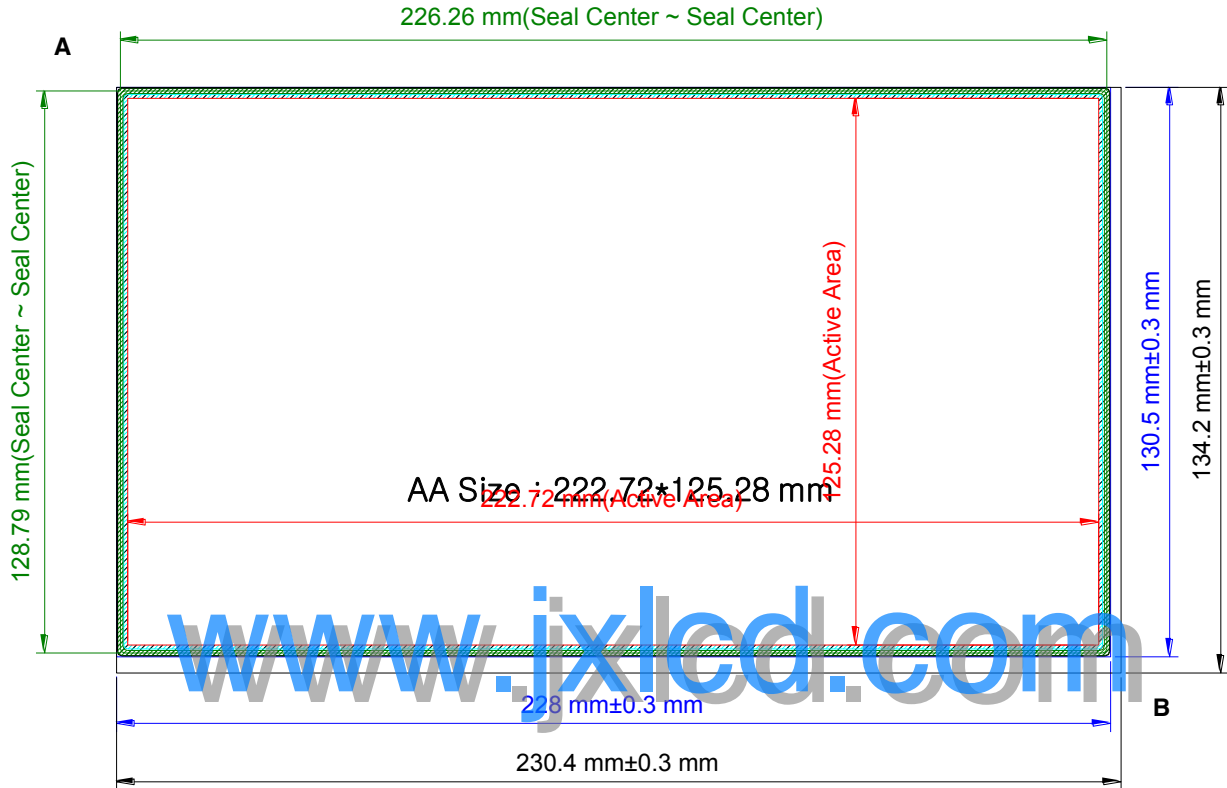
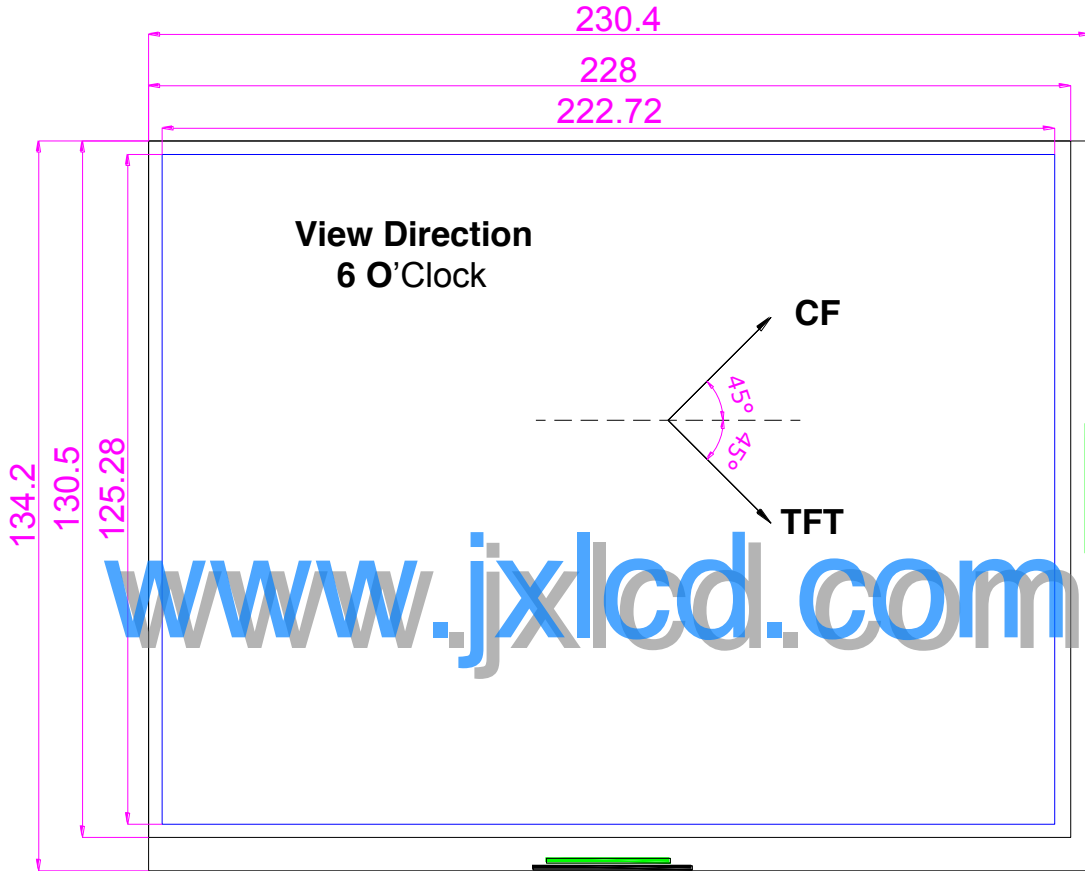

Figure 8. Seal on Panel



- * Seal width : 1.15±0.2mm
- * Scribing Accuracy : Target±0.3mm
- * Glass Thickness 0.5mm

Figure 9. Rubbing Direction



8.0 Packing (Single Cell)

www.jxlcd.com

9. Handling & Cautions

9.1 Mounting Method



- The panel of the LCD consists of two thin glasses with polarizers which easily get damaged. So extreme care should be taken when handling the LCD.
- Excessive stress or pressure on the glass of the LCD should be avoided. Care must be taken to insure that no torsional or compressive forces are applied to the LCD unit when it is mounted.
- If the customer's set presses the main parts of the LCD, the LCD may show the abnormal display. But this phenomenon does not mean the malfunction of the LCD and should be pressed by the way of mutual agreement.
- To determine the optimum mounting angle, refer to the viewing angle range in the specification for each model.
- Mount a LCD module with the specified mounting parts.

9.2 caution of LCD Handling and Cleaning

- Since the LCD is made of glass, do not apply strong mechanical impact or static load onto it. Handling with care since shock, vibration and careless handling may seriously affect the product. If it falls from a high place or receives a strong shock, the glass may be broken.
- The polarizers on the surface of panel are made from organic substances. Be very careful for chemicals not to touch the polarizers or it leads the polarizers to be deteriorated.
- If the use of a chemical is unavoidable, use soft cloth with solvent (recommended below) to clean the LCD's surface with wipe lightly.
-IPA(Isopropyl Alcohol), Ethyl Alcohol, Trichlorotrifluoroethane
- Do not wipe the LCD's surface with dry or hard materials that will damage the polarizers and others. Do not use the following solvent.
-Water, Ketone, Aromatics
- It is recommended that the LCD be handled with soft gloves during assembly, etc. The polarizers on the LCD's surface are vulnerable to scratch and thus to be damaged by sharp particles.
- Do not drop water or any chemicals onto the LCD's surface.
- A protective film is supplied on the LCD and should be left in place until the LCD is required for operation.
- The ITO pad area needs special careful caution because it could be easily corroded. Do not contact the ITO pad area with HCFC, Soldering flux, Chlorine, Sulfur, saliva or fingerprint. To prevent the ITO corrosion, customers are recommended that the ITO area would be covered by UV or silicon.

9.3 Caution Against Static Charge

- The LCD modules use C-MOS LSI drivers, so customers are recommended that any unused input terminal would be connected to Vdd or Vss, do not input any signals before power is turn on, and ground you body, work/assembly area, assembly equipments to protect against static electricity.
- Remove the protective film slowly, keeping the removing direction approximate 30-degree not vertical from panel surface, If possible, under ESD control device like ion blower, and the humidity of working room should be kept over 50%RH to reduce the risk of static charge.
- Avoid the use work clothing made of synthetic fibers. We recommend cotton clothing or other conductivity-treated fibers.
- In handling the LCD, wear non-charged material gloves. And the conducting wrist to the earth and the conducting shoes to the earth are necessary.

9.4 Caution For operation

- It is indispensable to drive the LCD within the specified voltage limit since the higher Voltage than the limit causes the shorter LCD's life. An electro-chemical reaction due to DC causes undesirable deterioration of the LCD so that the use of DC drive should avoid.
- Do not connect or disconnect the LCD to or from the system when power is on.
- Never use the LCD under abnormal conditions of high temperature and high humidity.
- When expose to drastic fluctuation of temperature (hot to cold or cold to hot) ,the LCD may be affected; Specifically, drastic temperature fluctuation from cold to hot ,produces dew on the LCD's surface which may affect the operation of the polarizer and the LCD.
- Response time will be extremely delayed at lower temperature than the operating temperature range and on the other hand at higher temperature LCD may turn black at temperature above its operational range. However those phenomena do not mean malfunction or out of order with the LCD. The LCD will revert to normal operation once the temperature returns to the recommended temperature range for normal operation.
- Do not display the fixed pattern for a long time because it may develop image sticking due to the LCD structure. If the screen is displayed with fixed pattern, use a screen saver.

9.5 Packaging

- Modules use LCD element, and must be treated as such.
 - Avoid intense shock and falls from a height.
 - To prevent modules from degradation, do not operate or store them exposed directly to sunshine or high temperature/humidity for long periods.

9.6 Storage

- A slight dew depositing on terminals is a cause for electro-chemical reaction resulting in terminal open circuit. Relative humidity of the environment should therefore be kept below 60%RH.
- Original protective film should be used on LCD's surface (polarizer). Adhesive type protective film should be avoided, because it may change color and/or properties of the polarizers.
- Do not store the LCD near organic solvents or corrosive gasses.
- Keep the LCD safe from vibration, shock and pressure.
- Black or white air-bubbles may be produced if the LCD is stored for long time in the lower temperature or mechanical shocks are applied onto the LCD.
- In the case of storing for a long period of time for the purpose or replacement use, the following ways are recommended.
 - Store in a polyethylene bag with sealed so as not to enter fresh air outside in it.
 - Store in a dark place where neither exposure to direct sunlight nor light is.
 - Keep temperature in the specified storage temperature range.
 - Store with no touch on polarizer surface by the anything else. If possible, store the LCD in the packaging situation LCD when it was delivered.

9.7 Safety

- For the crash damaged or unnecessary LCD, it is recommended to wash off liquid crystal by either of solvents such as acetone and ethanol and should be burned up later.
- In the case the LCD is broken, watch out whether liquid crystal leaks out or not. If your hands touch the liquid crystal, wash your hands cleanly with water and soap as soon as possible.
- If you should swallow the liquid crystal, first, wash your mouth thoroughly with water, then drink a lot of water and induce vomiting, and then, consult a physician.
- If the liquid crystal should get in your eyes, flush your eyes with running water for at least fifteen minutes.
- If the liquid crystal touches your skin or clothes, remove it and wash the affected part of your skin or clothes with soap and running water.