



PROPRIETARY NOTE
THIS SPECIFICATION IS THE PROPERTY OF BOE OT AND SHALL NOT BE REPRODUCED OR COPIED WITHOUT THE WRITTEN PERMISSION OF BOE OT AND MUST BE RETURNED TO BOE OT UPON ITS REQUEST

TITLE : BA104S01-100
Product Specification
Rev. 0

BEIJING BOE OPTOELECTRONICS TECHNOLOGY

SPEC. NUMBER SXXX-XXXX	PRODUCT GROUP TFT-LCD	REV. 0	ISSUE DATE 2012.02. 07	PAGE 1 OF 28
---------------------------	--------------------------	-----------	---------------------------	-----------------



京东方
BOE

PRODUCT GROUP

TFT LCD PRODUCT

REV

0

ISSUE DATE

2012.02.07.

REVISION HISTORY

REV.	ECN NO.	DESCRIPTION OF CHANGES	DATE	PREPARED
0	-	Initial Release	2012.02.07	Suyuefeng

SPEC. NUMBER SXXX-XXXX	SPEC TITLE BA104S01-100 Product Specification	PAGE 2 OF 28
---------------------------	--	-----------------



PROPRIETARY NOTE
THIS SPECIFICATION IS THE PROPERTY OF BOE OT AND SHALL NOT BE REPRODUCED OR COPIED WITHOUT THE WRITTEN PERMISSION OF BOE OT AND MUST BE RETURNED TO BOE OT UPON ITS REQUEST

Contents

No.	Items	Page
1.0	General Description	4
2.0	Absolute Maximum ratings	6
3.0	Electrical specifications.	7
4.0	Optical specifications.	9
5.0	Interface Connection	13
6.0	Signal Timing Specification	16
7.0	Signal Timing waveforms	18
8.0	Input Signals, Display Colors & Gray Scale of Colors	19
9.0	Power Sequence	20
10.0	Connector description	21
11.0	Mechanical Characteristics	22
12.0	Reliability Test	23
13.0	Handling & Cautions.	23
14.0	Label	24
15.0	Packing information	26
16.0	Mechanical Outline Dimension	27

SPEC. NUMBER
SXXX-XXXX

PRODUCT GROUP
TFT-LCD

REV.
0

ISSUE DATE
2012.02. 07

PAGE
3 OF 28

1.0 GENERAL DESCRIPTION

1.1 Introduction

10.4SVGA is a color active matrix TFT LCD module using amorphous silicon TFT's (Thin Film Transistors) as an active switching devices. This module has a 10.4 inch diagonally measured active area with SVGA resolutions (800 horizontal by 600 vertical pixel array). Each pixel is divided into RED, GREEN, BLUE dots which are arranged in vertical stripe and this module can display 262144 colors. The TFT-LCD panel used for this module is adapted for a low reflection and higher color type.

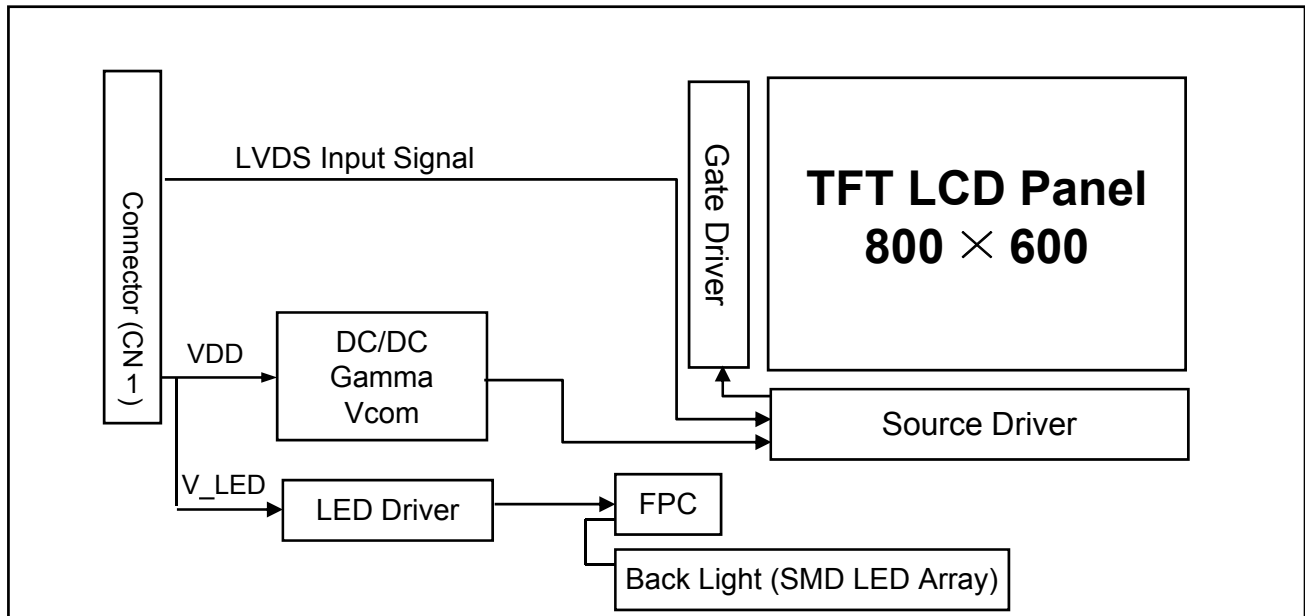

1.2 Features

- 1 Channel LVDS Interface with 1 pixel / clock
- Thin and light weight
- Display 262144 colors
- High luminance and contrast ratio, low reflection and wide viewing angle
- DE (Data Enable) signal mode
- 3.3V for Logic Power and LED Back Light Power
- RoHS Compliant

SPEC. NUMBER	PRODUCT GROUP	REV.	ISSUE DATE	PAGE
SXXX-XXXX	TFT-LCD	0	2012.02.07	4 OF 28

**PROPRIETARY NOTE**

THIS SPECIFICATION IS THE PROPERTY OF BOE OT AND SHALL NOT BE REPRODUCED OR COPIED WITHOUT THE WRITTEN PERMISSION OF BOE OT AND MUST BE RETURNED TO BOE OT UPON ITS REQUEST

1.3 Application

- Medical & Industrial application

1.4 General Specification

< Table 1. General Specifications >

Parameter	Specification	Unit	Remarks
Active area	211.20(H) x 158.40(V)	mm	
Number of pixels	800(H) × 600(V)	pixels	
Pixel pitch	0.088(H) × RGB × 0.264(V)	mm	
Pixel arrangement	Pixels RGB stripe arrangement		
Display colors	262K (6bits)	colors	
Display mode	Transmission mode, Normally White		
Outline Dimension	236.00(H) × 176.90(V) × 5.60(D) typ.	mm	
Weight	TBD	gram	
Surface Treatment	Hard Coating, 3H, AG		WV pol. is needed CF pol. :0. 215 TFT pol.:0. 215
Back-light	Top edge side, 1-LED Lighting Bar Type		

SPEC. NUMBER
SXXX-XXXXPRODUCT GROUP
TFT-LCDREV.
0ISSUE DATE
2012.02. 07PAGE
5 OF 28

PROPRIETARY NOTE

THIS SPECIFICATION IS THE PROPERTY OF BOE OT AND SHALL NOT BE REPRODUCED OR COPIED WITHOUT THE WRITTEN PERMISSION OF BOE OT AND MUST BE RETURNED TO BOE OT UPON ITS REQUEST

2.0 ABSOLUTE MAXIMUM RATINGS

The followings are maximum values which, if exceed, may cause faulty operation or damage to the unit. The operational and non-operational maximum voltage and current values are listed in Table 2.

< Table 2. LCD Module Electrical Specifications > [Ta =25±2 °C]

Parameter	Symbol	Min.	Typ.	Max.	Unit	Remarks
Power Supply Voltage (LCD Module)	V _{DD}	3.0	3.3	3.6	V	
Back-light Power Supply Voltage	HV _{DD}	17.7		21.3	V	
Back-light LED Current	I _{LED}	-	20		mA	
Operating Temperature	T _{OP}	-20		+70	°C	1)
Storage Temperature	T _{ST}	-30		+80	°C	

Note : 1) Temperature and relative humidity range are shown in the figure below.
Wet bulb temperature should be 39 °C max. and no condensation of water.

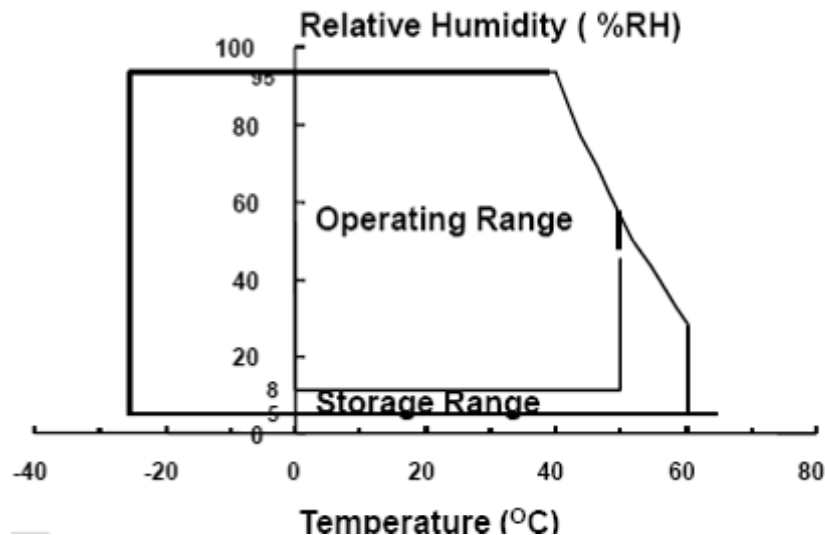

SPEC. NUMBER
SXXX-XXXX

PRODUCT GROUP
TFT-LCD

REV.
0

ISSUE DATE
2012.02.07

PAGE
6 OF 28



PROPRIETARY NOTE

THIS SPECIFICATION IS THE PROPERTY OF BOE OT AND SHALL NOT BE REPRODUCED OR COPIED WITHOUT THE WRITTEN PERMISSION OF BOE OT AND MUST BE RETURNED TO BOE OT UPON ITS REQUEST

3.0 ELECTRICAL SPECIFICATIONS

3.1 TFT LCD Module

< Table 3. LCD Module Electrical Specifications >

[Ta =25±2 °C]

Parameter	Symbol	Values			Unit	Notes
		Min	Typ	Max		
Power Supply Input Voltage	V _{DD}	3.0	3.3	3.6	V	-
Power Supply Current	I _{DD}	-		-	mA	-
Back-light Power Supply Voltage	H _{VDD}			21.3	V	-
Back-light Power Supply Current	I _{HVDD}		120		mA	6 parallel*6string
Positive-going Input Threshold Voltage	V _{IT+}	-	-	+100	mV	Vcom = 1.2V typ.
Negative-going Input Threshold Voltage	V _{IT-}	-100	-	-	mV	
Differential input common mode voltage	V _{com}	-	TBD	-	V	V _{IH} =100mV, V _{IL} =-100mV
Power Consumption	P _D	-	-	TBD	W	Note 1
	P _{BL}	-	-	2.484	W	Note 2
	P _{Total}		-	TBD	W	

SPEC. NUMBER
SXXX-XXXX

PRODUCT GROUP
TFT-LCD

REV.
0

ISSUE DATE
2012.02. 07

PAGE
7 OF 28



PROPRIETARY NOTE

THIS SPECIFICATION IS THE PROPERTY OF BOE OT AND SHALL NOT BE REPRODUCED OR COPIED WITHOUT THE WRITTEN PERMISSION OF BOE OT AND MUST BE RETURNED TO BOE OT UPON ITS REQUEST

3.2 Back-light Unit

< Table 4. LED Driving guideline specifications >

Ta=25+/-2°C

Parameter		Min.	Typ.	Max.	Unit	Remarks
LED Forward Voltage	V _F	2.95	-	3.55	V	-
LED Forward Current	I _F	-	20	-	mA	-
LED Power Consumption	P _{LED}	-	-	2.484	W	Note 1
LED Life-Time	N/A	15,000	(20,000)		Hour	IF = 20mA Note 2

Notes : 1. Calculator Value for reference $I_{LED} \times V_{LED} = P_{LED}$

2. The LED Life-time define as the estimated time to 50% degradation of initial luminous.

SPEC. NUMBER SXXX-XXXX	PRODUCT GROUP TFT-LCD	REV. 0	ISSUE DATE 2012.02. 07	PAGE 8 OF 28
---------------------------	--------------------------	-----------	---------------------------	-----------------



PROPRIETARY NOTE
 THIS SPECIFICATION IS THE PROPERTY OF BOE OT AND SHALL NOT BE REPRODUCED OR COPIED WITHOUT THE WRITTEN PERMISSION OF BOE OT AND MUST BE RETURNED TO BOE OT UPON ITS REQUEST

4.0 OPTICAL SPECIFICATION

4.1 Overview

The test of view angle range shall be measured in a dark room (ambient luminance \leq 1lux and temperature = $25\pm 2^\circ\text{C}$) with the equipment of Luminance meter system (Goniometer system and TOPCON BM-5A) and test unit shall be located at an approximate distance 50cm from the LCD surface at a viewing angle of θ and Φ equal to 0° . We refer to $\theta\Phi=0$ ($=\theta_3$) as the 3 o'clock direction (the "right"), $\theta\Phi=90$ ($=\theta_{12}$) as the 12 o'clock direction ("upward"), $\theta\Phi=180$ ($=\theta_9$) as the 9 o'clock direction ("left") and $\theta\Phi=270$ ($=\theta_6$) as the 6 o'clock direction ("bottom"). While scanning θ and/or Φ , the center of the measuring spot on the Display surface shall stay fixed. The luminance, color and uniformity is tested by CA210. The backlight should be operating for 30 minutes prior to measurement. VDD shall be $3.7 \pm 0.5\text{V}$ at 25°C . Optimum viewing angle direction is 6 o'clock.

4.2 Optical Specifications

<Table 5. Optical Specifications>

Parameter		Symbol	Condition	Min.	Typ.	Max.	Unit	Remark
Viewing Angle range	Horizontal	Θ_3	CR > 10	60	70	-	Deg.	Note 1
		Θ_9		60	70	-	Deg.	
	Vertical	Θ_{12}		50	60	-	Deg.	
		Θ_6		60	70	-	Deg.	
Color Gamut			-	50	-	%		
Luminance Contrast ratio		CR	$\Theta = 0^\circ$	300	400			Note 2
Luminance of White	Centre	Y_w	$\Theta = 0^\circ$	(350)	(400)	-	cd/m ²	Note 3
White Luminance uniformity	9 Points	ΔY_9		70%	80%	-		Note 4
	13 Points	ΔY_{13}		65%	-			
Reproduction of color	White	W_x	$\Theta = 0^\circ$	Typ. -0.05	TBD	Typ. +0.05		
		W_y			TBD			
	Red	R_x			TBD			
		R_y			TBD			
	Green	G_x			TBD			
		G_y			TBD			
	Blue	B_x			TBD			
		B_y			TBD			
Response Time (Rising + Falling)		T_{RT}	$T_a = 25^\circ\text{C}$ $\Theta = 0^\circ$	-	25	-	ms	Note 6
Cross Talk		CT	$\Theta = 0^\circ$	-	-	2.0	%	Note 7

SPEC. NUMBER SXXX-XXXX	PRODUCT GROUP TFT-LCD	REV. 0	ISSUE DATE 2012.02.07	PAGE 9 OF 28
---------------------------	--------------------------	-----------	--------------------------	-----------------



PROPRIETARY NOTE

THIS SPECIFICATION IS THE PROPERTY OF BOE OT AND SHALL NOT BE REPRODUCED OR COPIED WITHOUT THE WRITTEN PERMISSION OF BOE OT AND MUST BE RETURNED TO BOE OT UPON ITS REQUEST

Notes : 1. Viewing angle is the angle at which the contrast ratio is greater than 10. The viewing angles are determined for the horizontal or 3, 9 o'clock direction and the vertical or 6, 12 o'clock direction with respect to the optical axis which is normal to the LCD surface (see FIGURE 1).

2. Contrast measurements shall be made at viewing angle of $\Theta = 0$ and at the center of the LCD surface. Luminance shall be measured with all pixels in the view field set first to white, then to the dark (black) state. (see FIGURE 1) Luminance Contrast Ratio (CR) is defined mathematically.

$$CR = \frac{\text{Luminance when displaying a white raster}}{\text{Luminance when displaying a black raster}}$$

3. Center Luminance of white is defined as luminance values of 5point average across the LCD surface. Luminance shall be measured with all pixels in the view field set first to white. This measurement shall be taken at the locations shown in FIGURE 2 for a total of the measurements per display. The luminance is measured by CA210 when the LED current is set at 18.8mA.

4. The White luminance uniformity on LCD surface is then expressed as : $\Delta Y = \text{Minimum Luminance of 5 points} / \text{Maximum Luminance of 5 points}$ (see FIGURE 2).

5. The color chromaticity coordinates specified in Table 5 shall be calculated from the spectral data measured with all pixels first in red, green, blue and white. Measurements shall be made at the center of the panel.

6. The electro-optical response time measurements shall be made as FIGURE 3 by switching the "data" input signal ON and OFF. The times needed for the luminance to change from 10% to 90% is T_r , and 90% to 10% is T_d .

7. Cross-Talk of one area of the LCD surface by another shall be measured by comparing the luminance (YA) of a 25mm diameter area, with all display pixels set to a gray level, to the luminance (YB) of that same area when any adjacent area is driven dark. (See FIGURE 4).

SPEC. NUMBER	PRODUCT GROUP	REV.	ISSUE DATE	PAGE
SXXX-XXXX	TFT-LCD	0	2012.02. 07	10 OF 28

4.3 Optical measurements

Figure 1. Measurement Set Up

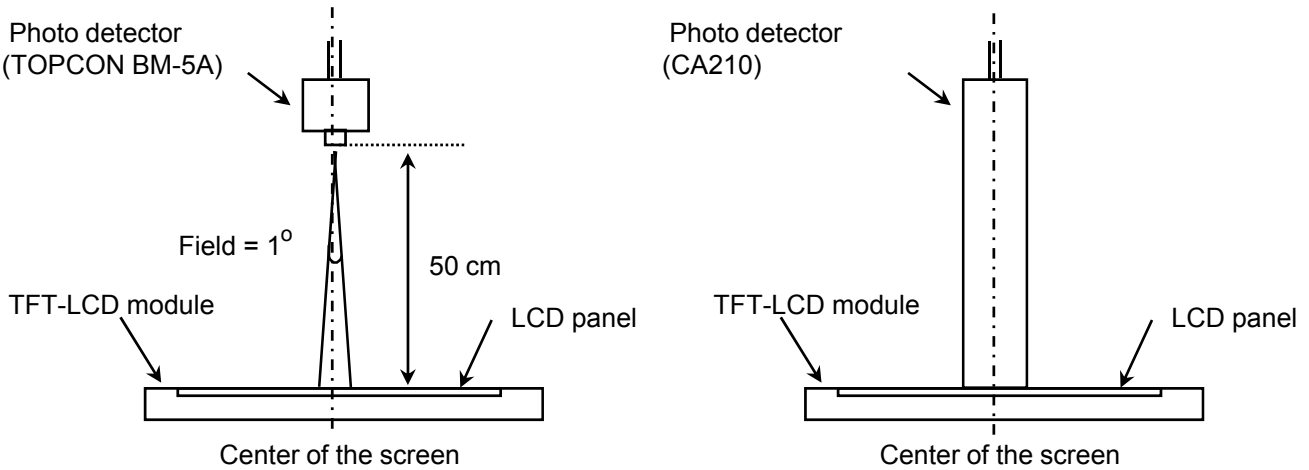

View angle measurement setup Luminance , uniformity and color measurement setup

Figure 2. White Luminance and Uniformity Measurement Locations (9 points)

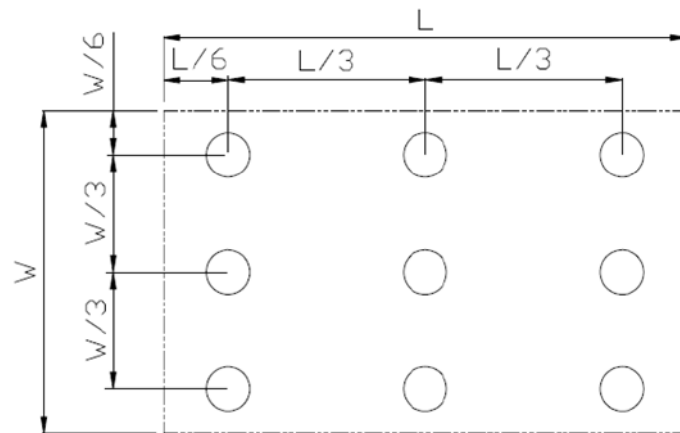

Center Luminance of white is defined as luminance values of center points across the LCD surface. Luminance shall be measured with all pixels in the view field set first to white. This measurement shall be taken at the locations shown in FIGURE 2 for a total of the measurements per display.

The White luminance uniformity on LCD surface is then expressed as : $\Delta Y5 = \text{Minimum Luminance of 5 points} / \text{Maximum Luminance of 5 points}$ (see FIGURE 2).

SPEC. NUMBER SXXX-XXXX	PRODUCT GROUP TFT-LCD	REV. 0	ISSUE DATE 2012.02.07	PAGE 11 OF 28
---------------------------	--------------------------	-----------	--------------------------	------------------

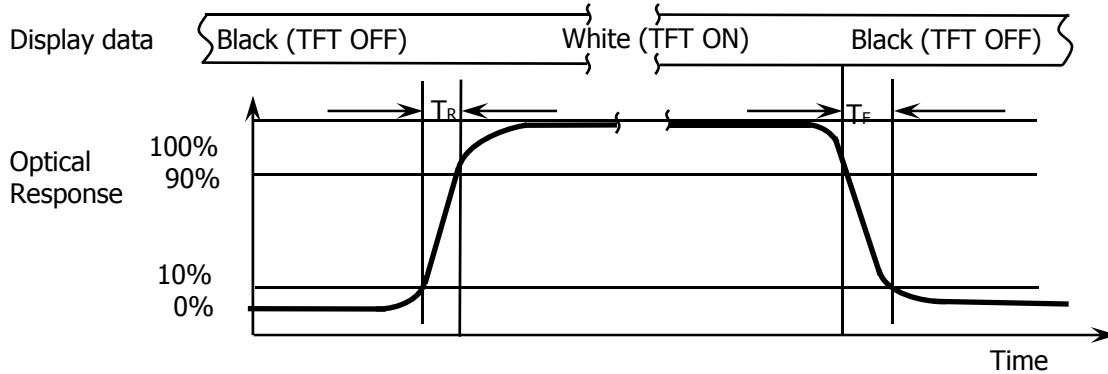
Figure 3. Response Time Testing

The electro-optical response time measurements shall be made as shown in FIGURE 3 by switching the “data” input signal ON and OFF. The times needed for the luminance to change from 10% to 90% is Tr and 90% to 10% is Td.

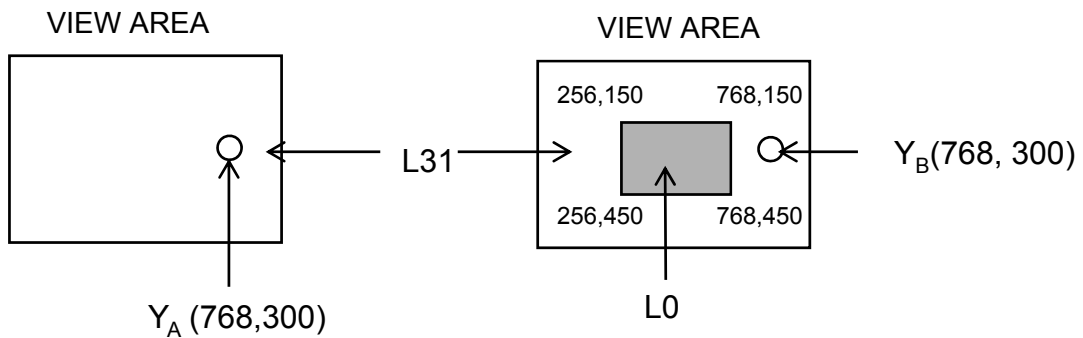
Figure 4. Cross Modulation Test Description

$$\text{Cross-Talk (\%)} = \left| \frac{Y_B - Y_A}{Y_A} \right| \times 100$$

Where:

Y_A = Initial luminance of measured area (cd/m²)

Y_B = Subsequent luminance of measured area (cd/m²)

The location measured will be exactly the same in both patterns

Cross-Talk of one area of the LCD surface by another shall be measured by comparing the luminance (Y_A) of a 25mm diameter area, with all display pixels set to a gray level, to the luminance (Y_B) of that same area when any adjacent area is driven dark (Refer to FIGURE 4).



PROPRIETARY NOTE
 THIS SPECIFICATION IS THE PROPERTY OF BOE OT AND SHALL NOT BE REPRODUCED OR COPIED WITHOUT THE WRITTEN PERMISSION OF BOE OT AND MUST BE RETURNED TO BOE OT UPON ITS REQUEST

5.0 INTERFACE CONNECTION.

5.1 Electrical Interface Connection

The electronics interface connector is Starconn 107A20-0021RA-G3-R or compatible
 The connector interface pin assignments are listed in Table 6.

<Table 6. Pin Assignments for the Interface Connector>

Pin	Symbol	Function
1	VDD	Logic power 3.3V (Panel logic)
2	VDD	Logic power 3.3V (Panel logic)
3	GND	Ground
4	GND	Ground
5	IN0-	LVDS receiver negative signal channel 0
6	IN0+	LVDS receiver positive signal channel 0
7	GND	Ground
8	IN1-	LVDS receiver negative signal channel 1
9	IN1+	LVDS receiver positive signal channel 1
10	GND	Ground
11	IN2-	LVDS receiver negative signal channel 2
12	IN2+	LVDS receiver positive signal channel 2
13	GND	Ground
14	CLK-	LVDS receiver negative signal clock
15	CLK+	LVDS receiver positive signal clock
16	GND	Ground
17	NC	No connection
18	NC	No connection
19	GND	Ground
20	GND	Ground

SPEC. NUMBER SXXX-XXXX	PRODUCT GROUP TFT-LCD	REV. 0	ISSUE DATE 2012.02. 07	PAGE 13 OF 28
---------------------------	--------------------------	-----------	---------------------------	------------------

5-2. LVDS Interface

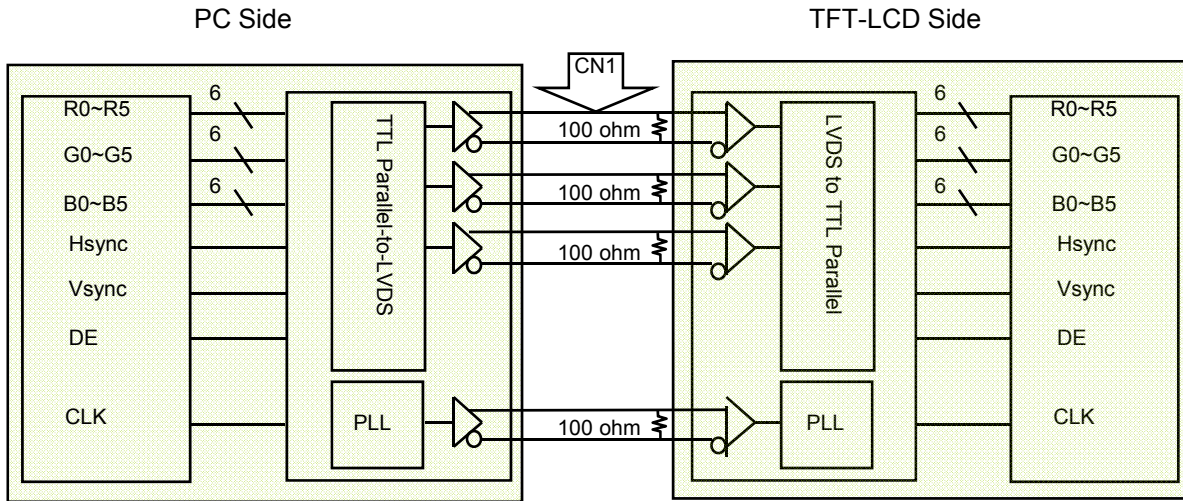

5.3. LVDS Input signal

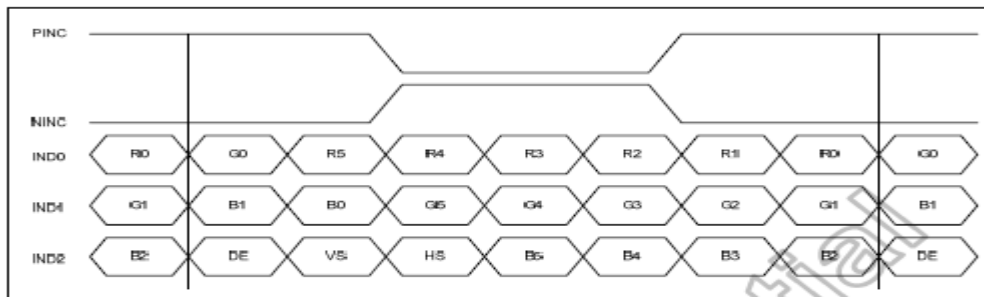

Figure 10.4: 6-bit LVDS input

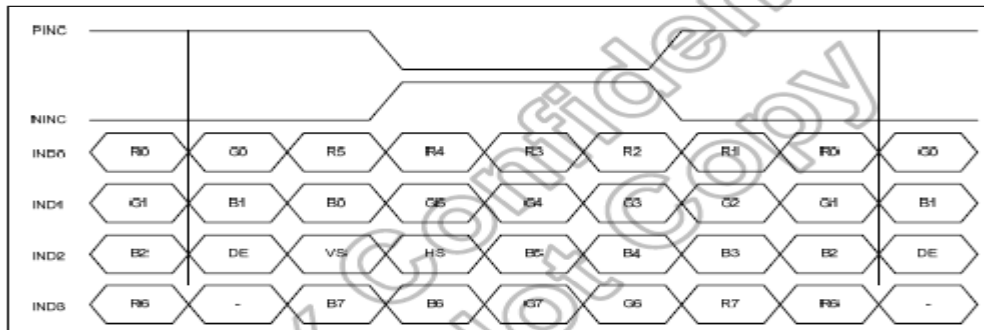

Figure 10.5: 8-bit LVDS Input

SPEC. NUMBER
SXXX-XXXX

PRODUCT GROUP
TFT-LCD

REV.
0

ISSUE DATE
2012.02.07

PAGE
14 OF 28

5.4 Data Input Format

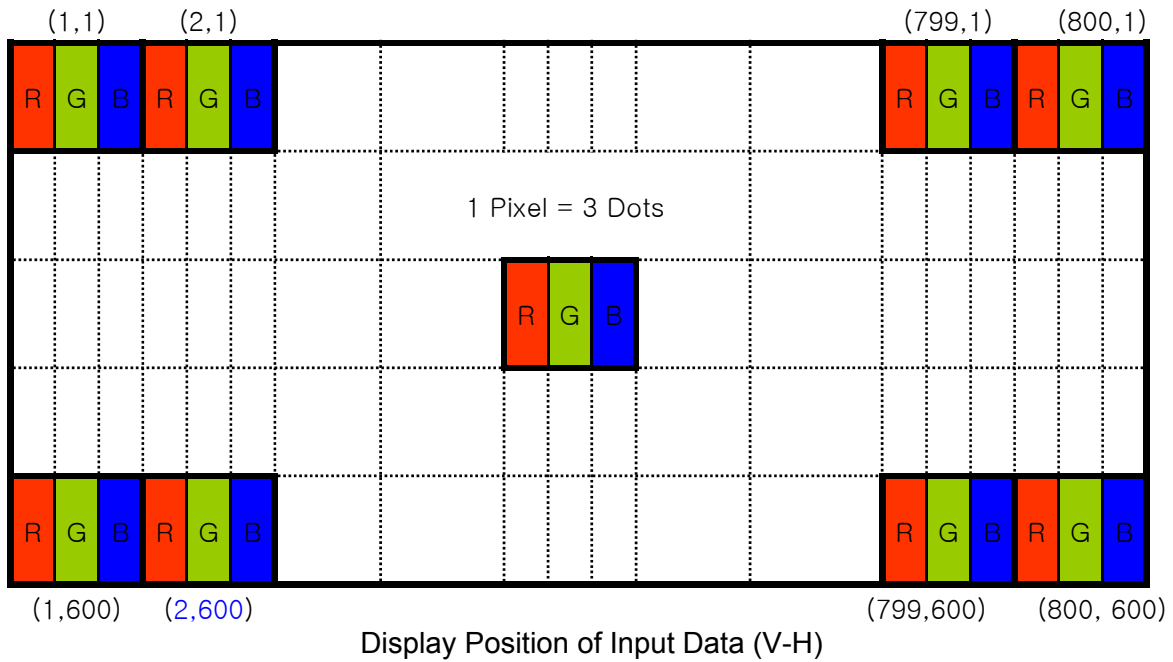
 SPEC. NUMBER
SXXX-XXXX

 PRODUCT GROUP
TFT-LCD

 REV.
0

 ISSUE DATE
2012.02.07

 PAGE
15 OF 28

**PROPRIETARY NOTE**

THIS SPECIFICATION IS THE PROPERTY OF BOE OT AND SHALL NOT BE REPRODUCED OR COPIED WITHOUT THE WRITTEN PERMISSION OF BOE OT AND MUST BE RETURNED TO BOE OT UPON ITS REQUEST

6.0 SIGNAL TIMING SPECIFICATION

6.1 The BA104S01-100 is operated by the DE only.

DE mode

Parameter	Symbol	Spec.			Unit
		Min.	Typ.	Max.	
DCLK Frequency	fcik	32.6	39.6	62.4	MHz
Horizontal Display Area	thd	800			DCLK
HSD Period	th	890	1000	1300	DCLK
HSD Blanking	thb+ thfp	90	200	500	DCLK
Vertical Display Area	tvd	600			T _H
VSD Period	tv	610	660	800	T _H
VSD Blanking	tvbp+ tvfp	10	60	200	T _H

Table 10.10: DE mode (800x600)

SPEC. NUMBER
SXXX-XXXX

PRODUCT GROUP
TFT-LCD

REV.
0

ISSUE DATE
2012.02. 07

PAGE
16 OF 28

6.2 LVDS Rx Interface Timing Parameter

The specification of the LVDS Rx interface timing parameter is shown in Table 8.

<Table 8. LVDS Rx Interface Timing Specification>

Parameter	Symbol	Spec.			Unit	Condition
		Min.	Typ.	Max.		
Clock frequency	R_{XFCLK}	20	-	71	MHz	-
Input data skew margin	T_{RSKM}	500	-	-	pS	$ V_{ID} =400mV$ $R_{XVCM}=1.2V$ $R_{XFCLK}=71MHz$
Clock high time	T_{LVCH}	-	$4/(7 * R_{XFCLK})$	-	ns	-
Clock low time	T_{LVCL}	-	$3/(7 * R_{XFCLK})$	-	ns	-
PLL wake-up time	T_{enPLL}	-	-	150	μs	-

Table 10.2: LVDS mode AC electrical characteristics

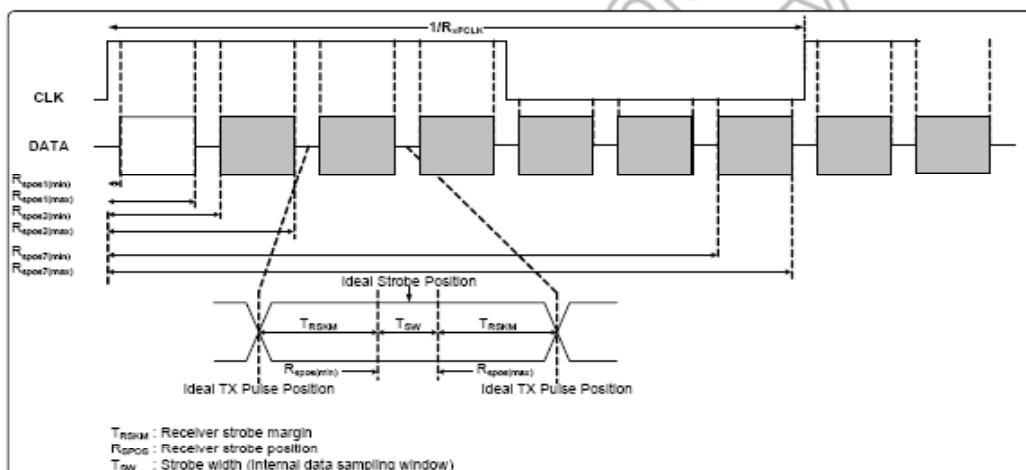
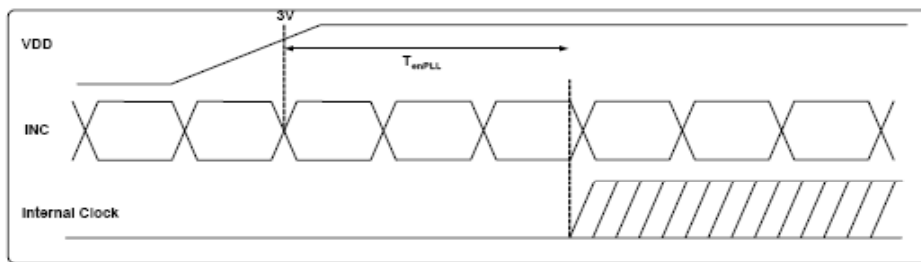
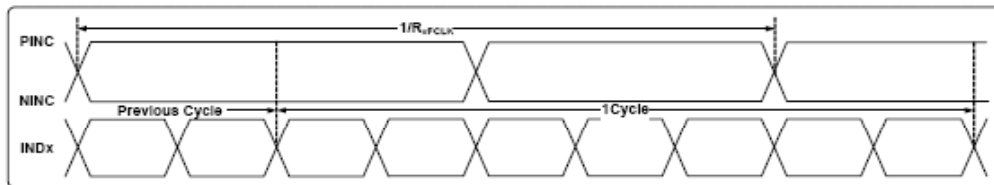

Figure 10.1: LVDS figure

7.0 SIGNAL TIMING WAVEFORMS OF INTERFACE SIGNAL

Timing Diagram

1. Input Clock and Data Timing Diagram

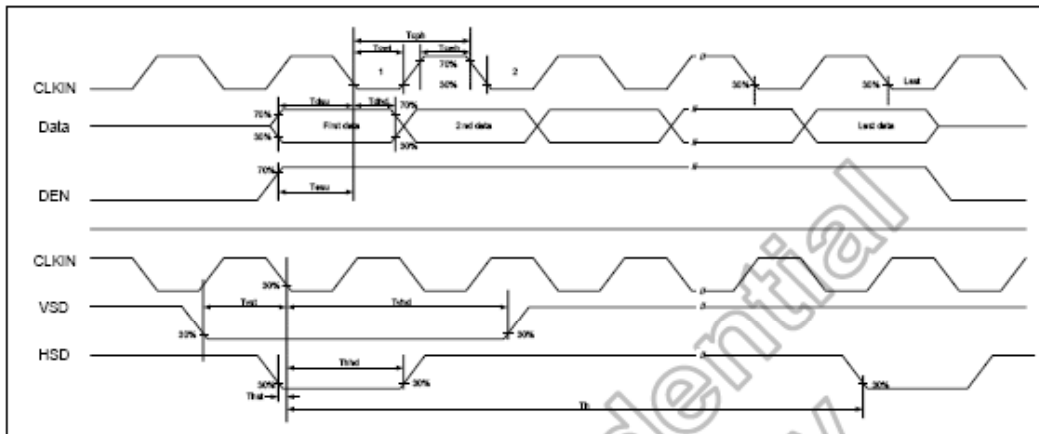

Figure 11.1: Input clock and data timing diagram

2. Source Output Timing Diagram

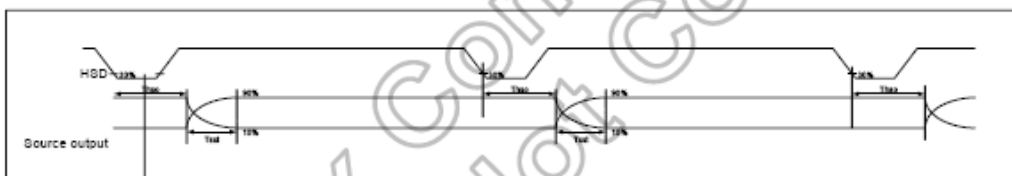

Figure 11.2: Source output timing diagram

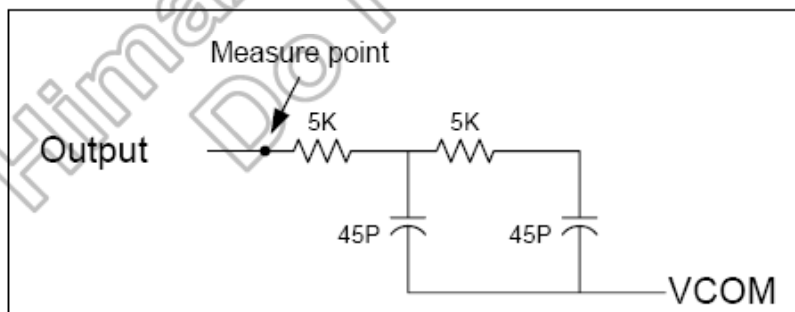

Figure 11.3: Output load condition

8.0 INPUT SIGNALS, BASIC DISPLAY COLORS & GRAY SCALE OF COLORS

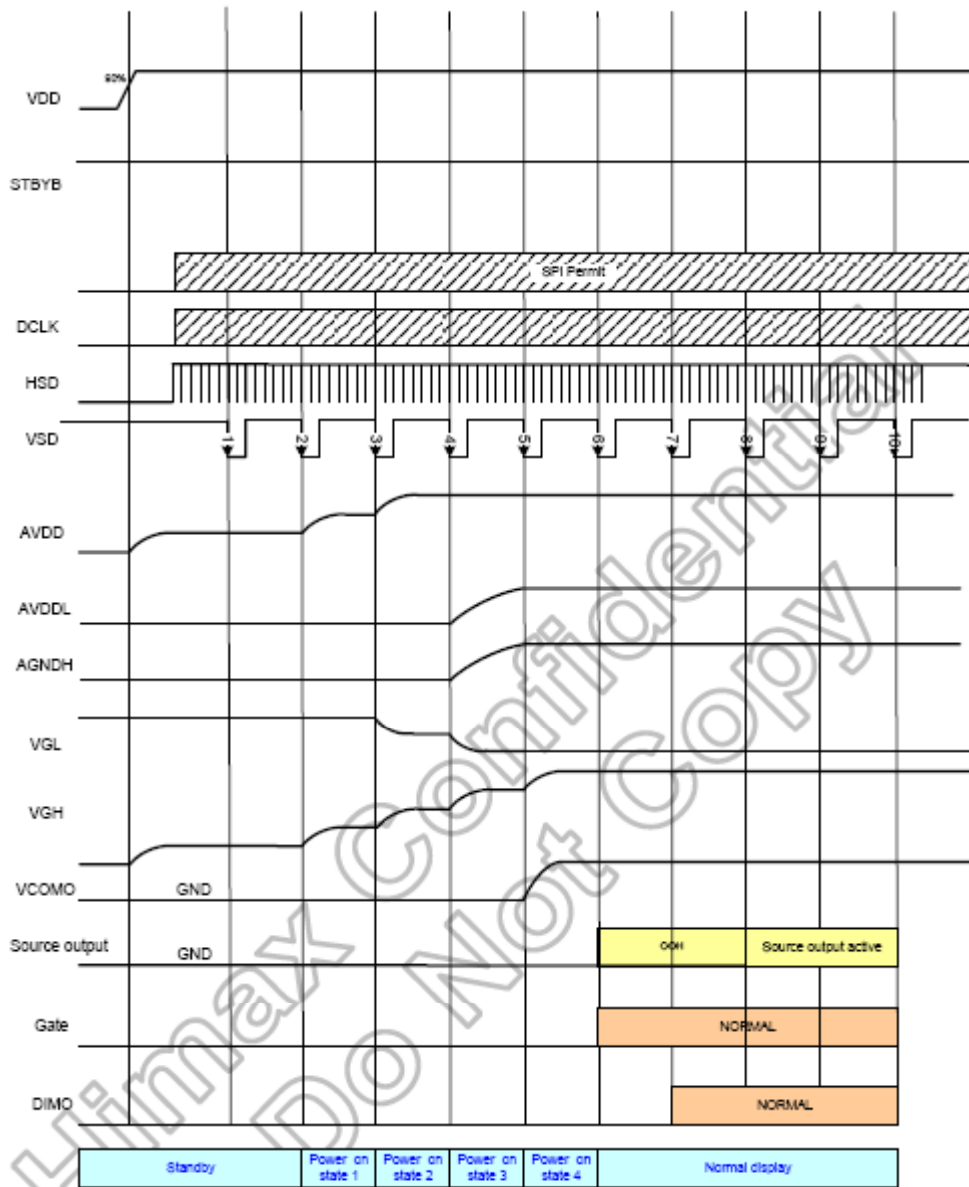
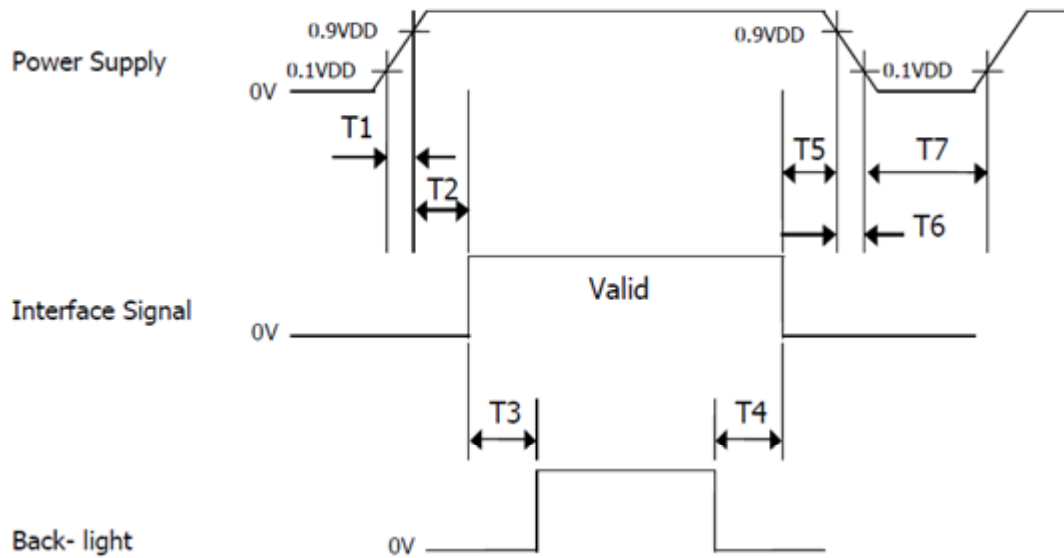

Figure 8.1: Power on timing sequence

9.0 POWER SEQUENCE



Parameter	Values			Units
	Min	Typ	Max	
T1	0.5	-	10	ms
T2	0	-	50	ms
T3	200	-	-	ms
T4	200	-	-	ms
T5	0.5	-	50	ms
T6	0	-	10	ms
T7	500	-	-	ms



PROPRIETARY NOTE

THIS SPECIFICATION IS THE PROPERTY OF BOE OT AND SHALL NOT BE REPRODUCED OR COPIED WITHOUT THE WRITTEN PERMISSION OF BOE OT AND MUST BE RETURNED TO BOE OT UPON ITS REQUEST

10.0 Connector Description

Physical interface is described as for the connector on LCM.

These connectors are capable of accommodating the following signals and will be following components.

10.1 TFT LCD Module

Connector Name /Description	For Signal Connector
Manufacturer	STARCONN
Type/ Part Number	Starconn 107A20-0021RA-G3-R or compatible

10.2 LED Connector

CONNECTOR:JST BHSR-02VS-1H

SPEC. NUMBER SXXX-XXXX	PRODUCT GROUP TFT-LCD	REV. 0	ISSUE DATE 2012.02. 07	PAGE 21 OF 28
---------------------------	--------------------------	-----------	---------------------------	------------------



PROPRIETARY NOTE
 THIS SPECIFICATION IS THE PROPERTY OF BOE OT AND SHALL NOT BE REPRODUCED OR COPIED WITHOUT THE WRITTEN PERMISSION OF BOE OT AND MUST BE RETURNED TO BOE OT UPON ITS REQUEST

11.0 MECHANICAL CHARACTERISTICS

11.1 Dimensional Requirements

FIGURE 5 shows mechanical outlines for the model HV070WSA-100. Other parameters are shown in Table 9.

<Table 9. Dimensional Parameters>

Parameter	Specification	Unit
Active Area	211.2 (H) × 158.4(V)	
Number of pixels	800(H) X600 (V) (1 pixel = R + G + B dots)	
Pixel pitch	0..03925 (H) X 0.11775 (V)	
Pixel arrangement	RGB Vertical stripe	
Display colors	262144	
Display mode	Normally White	
Dimensional outline	236*1176.9*5.6 (Typ.)	mm
Weight	288 (Typ.)(+/-15%)	gram
Back-light	LED, Horizontal-LED Array type	

11.2 Mounting

See FIGURE 6.

11.3 Glare and Polarizer Hardness.

The surface of the LCD has an low reflection coating and hard coating to reduce scratching.

11.4 Light Leakage

There shall not be visible light from the back-lighting system around the edges of the screen as seen from a distance 50cm from the screen with an overhead light level of 150lux.

SPEC. NUMBER SXXX-XXXX	PRODUCT GROUP TFT-LCD	REV. 0	ISSUE DATE 2012.02. 07	PAGE 22 OF 28
---------------------------	--------------------------	-----------	---------------------------	------------------

**PROPRIETARY NOTE**

THIS SPECIFICATION IS THE PROPERTY OF BOE OT AND SHALL NOT BE REPRODUCED OR COPIED WITHOUT THE WRITTEN PERMISSION OF BOE OT AND MUST BE RETURNED TO BOE OT UPON ITS REQUEST

12.0 RELIABILITY TEST

The Reliability test items and its conditions are shown in below.

<Table 10. Reliability test>

No	Test Items	Conditions
1	High temperature storage test	Ta = 80 °C, 240 hrs
2	Low temperature storage test	Ta = -30 °C, 240 hrs
3	High temperature & high humidity operation test	Ta = 60 °C, 90%RH, 240 hrs
4	High temperature operation test	Ta = 70 °C, 240 hrs
5	Low temperature operation test	Ta = -20 °C, 240hrs
6	Thermal shock	Ta = -20 °C ↔ 70 °C (30min), 100 cycle
7	Electro Static Discharge(operation)	C=150pF,R=330Ω; Air: ± 15Kv;Contact: ± 8Kv, 10times/terminal

13.0 HANDLING & CAUTIONS

(1) Cautions when taking out the module

- Pick the pouch only, when taking out module from a shipping package.

(2) Cautions for handling the module

- As the electrostatic discharges may break the LCD module, handle the LCD module with care. Peel a protection sheet off from the LCD panel surface as slowly as possible.
- As the LCD panel and back - light element are made from fragile glass material, impulse and pressure to the LCD module should be avoided.
- As the surface of the polarizer is very soft and easily scratched, use a soft dry cloth without chemicals for cleaning.
- Do not pull the interface connector in or out while the LCD module is operating.
- Put the module display side down on a flat horizontal plane.
- Handle connectors and cables with care.

(3) Cautions for the operation

- When the module is operating, do not lose CLK, ENAB signals. If any one of these signals is lost, the LCD panel would be damaged.
- Obey the supply voltage sequence. If wrong sequence is applied, the module would be damaged.

SPEC. NUMBER SXXX-XXXX	PRODUCT GROUP TFT-LCD	REV. 0	ISSUE DATE 2012.02. 07	PAGE 23 OF 28
---------------------------	--------------------------	-----------	---------------------------	------------------



PROPRIETARY NOTE

THIS SPECIFICATION IS THE PROPERTY OF BOE OT AND SHALL NOT BE REPRODUCED OR COPIED WITHOUT THE WRITTEN PERMISSION OF BOE OT AND MUST BE RETURNED TO BOE OT UPON ITS REQUEST

(4) Cautions for the atmosphere

- Dew drop atmosphere should be avoided.
- Do not store and/or operate the LCD module in a high temperature and/or humidity atmosphere. Storage in an electro-conductive polymer packing pouch and under relatively low temperature atmosphere is recommended.

(5) Cautions for the module characteristics

- Do not apply fixed pattern data signal to the LCD module at product aging.
- Applying fixed pattern for a long time may cause image sticking.

(6) Other cautions

- Do not disassemble and/or re-assemble LCD module.
- Do not re-adjust variable resistor or switch etc.
- When returning the module for repair or etc., Please pack the module not to be broken. We recommend to use the original shipping packages.

14.0 LABEL

(1) Product label



1 2 3 4 5 6 7

X	X	X	X	X	X	1	0	0	X	X	X	X	X	X	X	X
---	---	---	---	---	---	---	---	---	---	---	---	---	---	---	---	---

Type designation

No 5. Month (1, 2, 3, ..., 9, X, Y, Z)

No 1. Control Number

No 6. Product Identification (FG)

No 2. Rank / Grade

No 7. Serial Number

No 3. Line classification (BOE OT:A/BC)

No 4. Year (09 : 2009, 10: 2010, ...)

SPEC. NUMBER SXXX-XXXX	PRODUCT GROUP TFT-LCD	REV. 0	ISSUE DATE 2012.02. 07	PAGE 24 OF 28
---------------------------	--------------------------	-----------	---------------------------	------------------



PROPRIETARY NOTE

THIS SPECIFICATION IS THE PROPERTY OF BOE OT AND SHALL NOT BE REPRODUCED OR COPIED WITHOUT THE WRITTEN PERMISSION OF BOE OT AND MUST BE RETURNED TO BOE OT UPON ITS REQUEST

(2) High voltage caution label

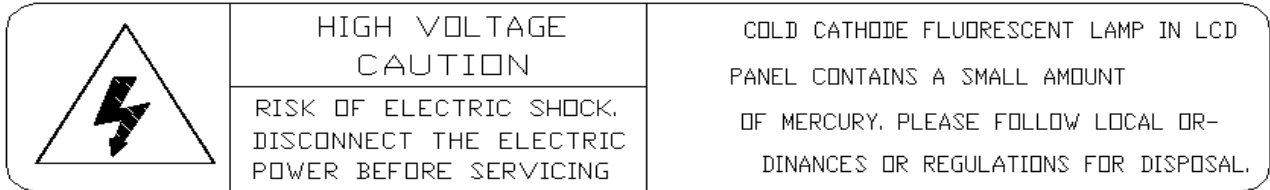

(3) Box label

Label Size: 110 mm (L) × 56 mm (W)

Contents

Model: BA104S01-100

Q`ty: Module Q`ty in one box

Serial No.: Box Serial No. See next figure for detail description.

Date: Packing Date

Internal use of Product

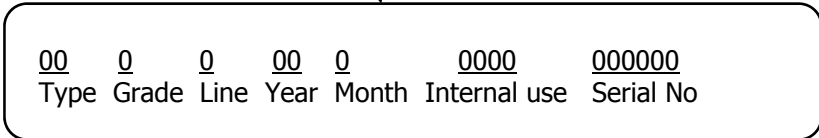

SPEC. NUMBER SXXX-XXXX	PRODUCT GROUP TFT-LCD	REV. 0	ISSUE DATE 2012.02.07	PAGE 25 OF 28
---------------------------	--------------------------	-----------	--------------------------	------------------



PROPRIETARY NOTE

THIS SPECIFICATION IS THE PROPERTY OF BOE OT AND SHALL NOT BE REPRODUCED OR COPIED WITHOUT THE WRITTEN PERMISSION OF BOE OT AND MUST BE RETURNED TO BOE OT UPON ITS REQUEST

15.0 PACKING INFORMATION

15.1 Packing order

TBD

SPEC. NUMBER SXXX-XXXX	PRODUCT GROUP TFT-LCD	REV. 0	ISSUE DATE 2012.02.07	PAGE 26 OF 28
---------------------------	--------------------------	-----------	--------------------------	------------------

PROPRIETARY NOTE

THIS SPECIFICATION IS THE PROPERTY OF BOE OT AND SHALL NOT BE REPRODUCED OR COPIED WITHOUT THE WRITTEN PERMISSION OF BOE OT AND MUST BE RETURNED TO BOE OT UPON ITS REQUEST

Figure 7. TFT-LCD Module Outline Dimensions (Rear view)

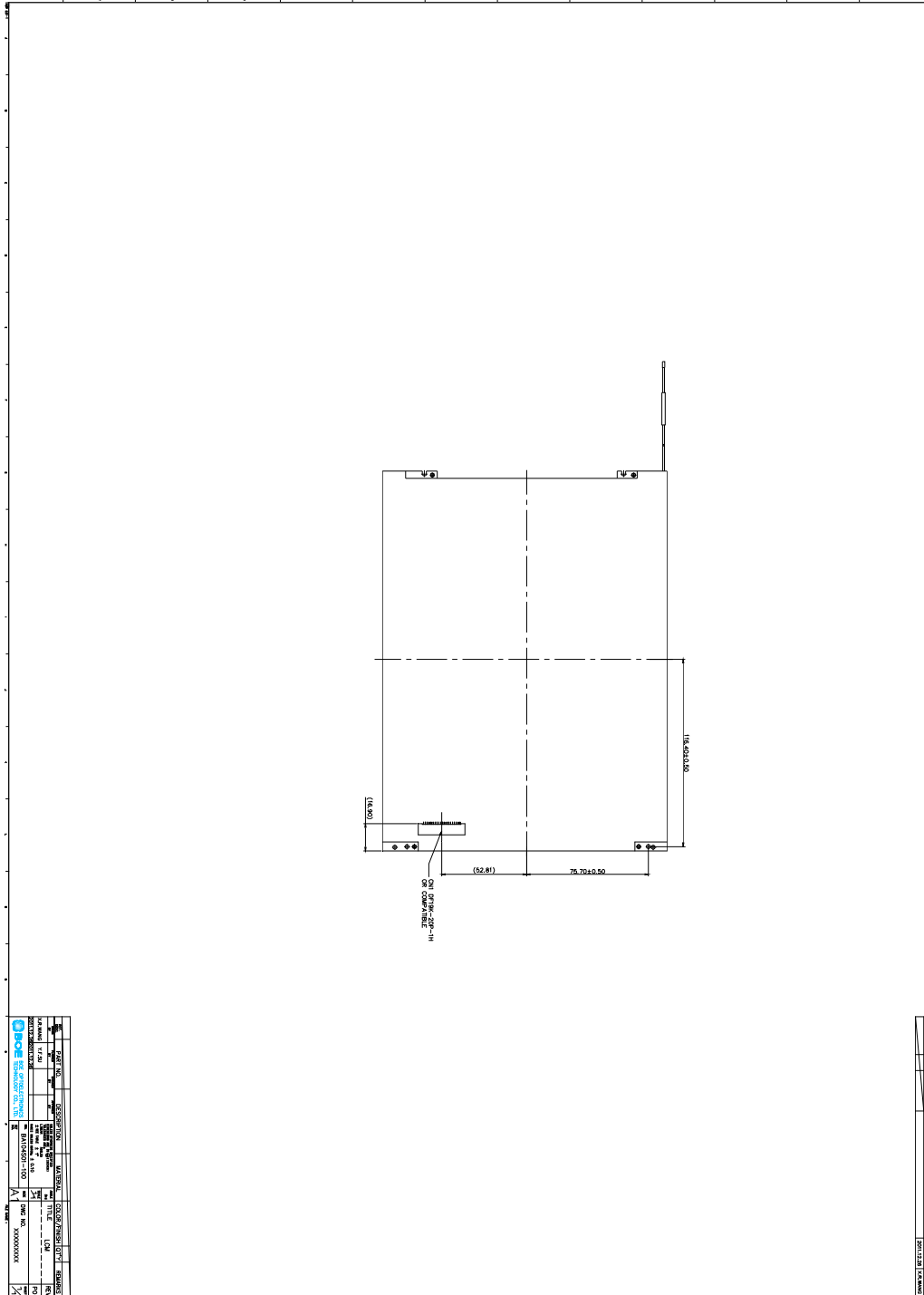

SPEC. NUMBER SXXX-XXXX	PRODUCT GROUP TFT-LCD	REV. 0	ISSUE DATE 2012.02. 07	PAGE 28 OF 28
---------------------------	--------------------------	-----------	---------------------------	------------------