

- Tentative Specification
- Preliminary Specification
- Approval Specification

MODEL NO.: M170EGE  
SUFFIX: L20

<b>Customer:</b>	
<b>APPROVED BY</b>	<b>SIGNATURE</b>
Name / Title _____	_____
Note	
<hr/> Please return 1 copy for your confirmation with your signature and comments.	

Approved By	Checked By	Prepared By
吳柏勳	邱千芳	劉潔

**CONTENTS**

<b>1. GENERAL DESCRIPTION .....</b>	<b>5</b>
1.1 OVERVIEW .....	5
1.2 GENERAL SPECIFICATIONS .....	5
<b>2. MECHANICAL SPECIFICATIONS .....</b>	<b>5</b>
<b>3. ABSOLUTE MAXIMUM RATINGS .....</b>	<b>6</b>
3.1 ABSOLUTE RATINGS OF ENVIRONMENT .....	6
3.2 ELECTRICAL ABSOLUTE RATINGS .....	6
3.2.1 TFT LCD MODULE .....	6
3.2.2 BACKLIGHT UNIT .....	7
<b>4. ELECTRICAL SPECIFICATIONS .....</b>	<b>7</b>
4.1 FUNCTION BLOCK DIAGRAM .....	7
4.2. INTERFACE CONNECTIONS .....	8
4.3 ELECTRICAL CHARACTERISTICS .....	9
4.3.1 LCD ELETRONICS SPECIFICATION .....	9
4.3.2 Vcc Power Dip Condition .....	12
4.3.3 BACKLIGHT UNIT (LED matrix is 12S4P) .....	12
4.3.4 LIGHTBAR Connector Pin Assignment .....	13
4.4 LVDS INPUT SIGNAL SPECIFICATIONS .....	14
4.4.1 LVDS DATA MAPPING TABLE .....	14
4.4.2 COLOR DATA INPUT ASSIGNMENT .....	15
4.5 DISPLAY TIMING SPECIFICATIONS .....	16
4.6 POWER ON/OFF SEQUENCE .....	18
<b>5. OPTICAL CHARACTERISTICS .....</b>	<b>19</b>
5.1 TEST CONDITIONS .....	19
5.2 OPTICAL SPECIFICATIONS .....	19
<b>6. RELIABILITY TEST ITEM .....</b>	<b>22</b>
<b>7. PACKING .....</b>	<b>23</b>
7.1 PACKING SPECIFICATIONS .....	23
7.2 PACKING METHOD .....	23
7.3 PALLET .....	24
<b>8. CMI MODULE LABEL .....</b>	<b>25</b>
<b>9. PRECAUTIONS .....</b>	<b>26</b>
9.1 ASSEMBLY AND HANDLING PRECAUTIONS .....	26
9.2 STORAGE PRECAUTIONS .....	27
9.3 OPERATION PRECAUTIONS .....	27

9.4 SAFETY PRECAUTIONS .....	27
9.5 SAFETY STANDARDS .....	27
9.6 OTHER .....	27
<b>Appendix. OUTLINE DRAWING .....</b>	<b>27</b>



## 1. GENERAL DESCRIPTION

### 1.1 OVERVIEW

M170EGE-L20 is a 17" TFT Liquid Crystal Display module with WLED Backlight unit and 32 pins 2ch-LVDS interface. This module supports 1280 x 1024 SXGA mode and can display up to 16.7M colors. The converter module for Backlight is not built in.

### 1.2 GENERAL SPECIFICATIONS

Item	Specification	Unit	Note
Screen Size	17" real diagonal	-	-
Driver Element	a-si TFT active matrix	-	-
Pixel Number	1280 x R.G.B. x 1024, SXGA resolution	pixel	-
Pixel Pitch	0.264 (H) x 0.264 (V)	mm	-
Pixel Arrangement	RGB vertical stripe	-	-
Display Colors	16.7M	color	-
Transmissive Mode	Normally white	-	-
Surface Treatment	AG type, 3H hard coating, Haze 25	-	-
Luminance, White	250nits (Typ.)	Cd/m2	-
Color Gamut	72% of NTSC(Typ.)	-	-
TCO	TCO 5.0 compliance	-	-
Power Consumption	Total 16.261 W (Max.) @ cell 5.0 W (Max.), BL11.261W (Max.)	-	(1)

Note (1) The specified power consumption : Total= cell (reference 4.3.1)+BL (reference 4.3.3)

## 2. MECHANICAL SPECIFICATIONS

Item	Min.	Typ.	Max.	Unit	Note	
Module Size	Horizontal (H)	358.0	358.5	359.0	mm	(1)
	Vertical (V)	296.0	296.5	297.0	mm	
	Thickness (T)	-	10.5	11.0	mm	
Bezel Area	Horizontal	341.7	341.9	342.1	mm	
	Vertical	274.2	274.4	274.6	mm	
Active Area	Horizontal	-	337.92	-	mm	
	Vertical	-	270.336	-	mm	
Weight	-	1500	1600	g		

Note (1) Please refer to the attached drawings for more information of front and back outline dimensions.

### 3. ABSOLUTE MAXIMUM RATINGS

#### 3.1 ABSOLUTE RATINGS OF ENVIRONMENT

Item	Symbol	Value		Unit	Note
		Min.	Max.		
Storage Temperature	TST	-20	60	°C	(1)
Operating Ambient Temperature	TOP	0	50	°C	(1), (2)

Note (1)

(a) 90 %RH Max. ( $T_a \leq 40$  °C).

(b) Wet-bulb temperature should be 39 °C Max. ( $T_a > 40$  °C).

(c) No condensation.

Note (2) The temperature of panel surface should be 0 °C min. and 60 °C max.

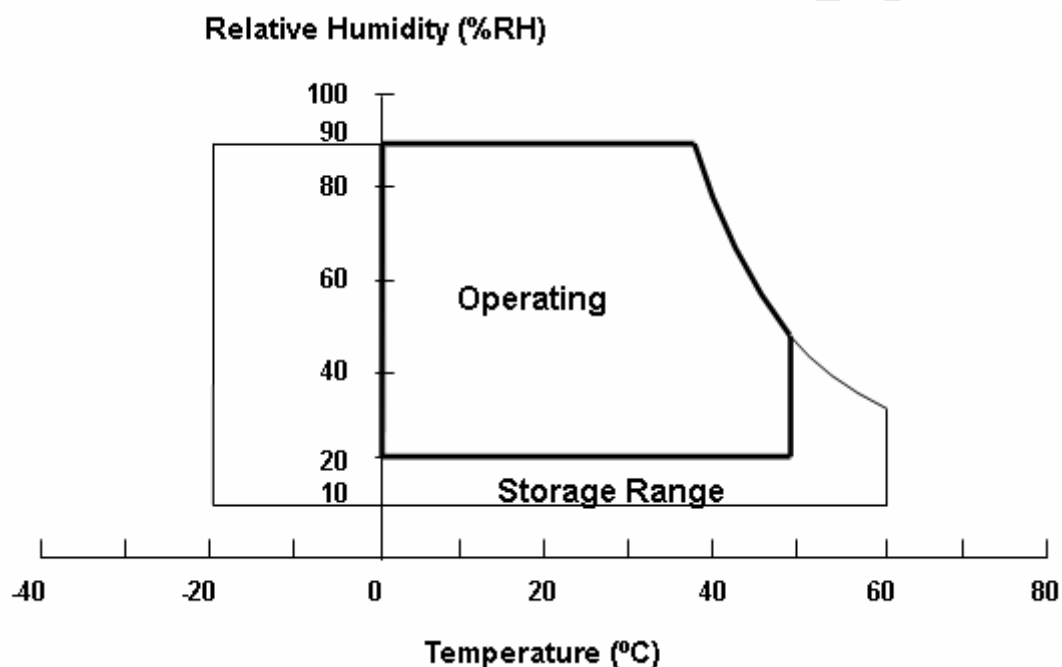

### 3.2 ELECTRICAL ABSOLUTE RATINGS

#### 3.2.1 TFT LCD MODULE

Item	Symbol	Value		Unit	Note
		Min.	Max.		
Power Supply Voltage	VCCS	-0.3	6.0	V	(1)
Logic Input Voltage	$V_{IN}$	-0.3	3.6	V	

### 3.2.2 BACKLIGHT UNIT

Item	Symbol	Value			Unit	Note
		Min.	Typ	Max.		
LED Forward Current Per Input Pin	$I_F$	0	65	69	mA	(1), (2) Duty=100%
LED Pulse Forward Current Per Input Pin	$I_P$	---	---	150	mA	(1), (2) Pulse Width $\leq 10$ msec. and Duty $\leq 30\%$

Note (1) Permanent damage to the device may occur if maximum values are exceeded. Function operation should be restricted to the conditions described under Normal Operating Conditions.

Note (2) Specified values are for input pin of LED light bar at  $T_a=25\pm 2$  °C (Refer to 4.3.3 and 4.3.4 for further information).

## 4. ELECTRICAL SPECIFICATIONS

### 4.1 FUNCTION BLOCK DIAGRAM

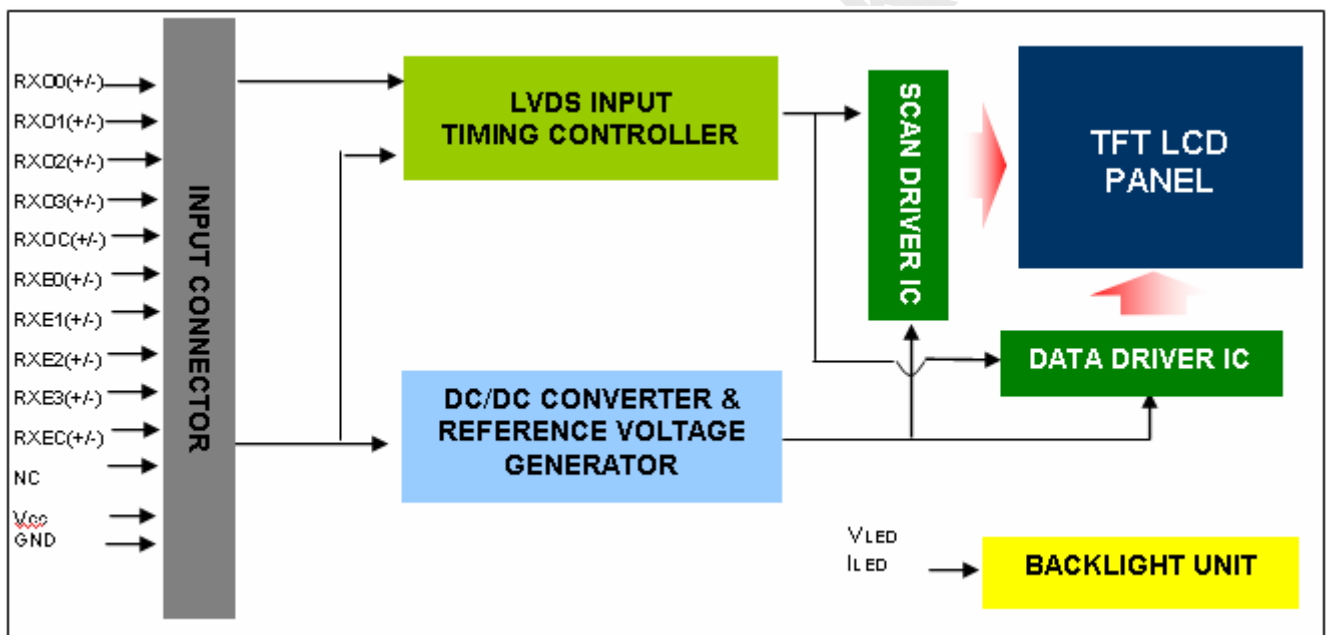

## 4.2. INTERFACE CONNECTIONS

### PIN ASSIGNMENT

Pin	Name	Description
1	GND	GND
2	RXO0-	Negative LVDS differential data input. Channel O0 (odd)
3	RXO0+	Positive LVDS differential data input. Channel O0 (odd)
4	RXO1-	Negative LVDS differential data input. Channel O1 (odd)
5	RXO1+	Positive LVDS differential data input. Channel O1 (odd)
6	RXO2-	Negative LVDS differential data input. Channel O2 (odd)
7	RXO2+	Positive LVDS differential data input. Channel O2 (odd)
8	GND	GND
9	RXOC-	Negative LVDS differential clock input. (odd)
10	RXOC+	Positive LVDS differential clock input. (odd)
11	RXO3-	Negative LVDS differential data input. Channel O3(odd)
12	RXO3+	Positive LVDS differential data input. Channel O3 (odd)
13	RXE0-	Negative LVDS differential data input. Channel E0 (even)
14	RXE0+	Positive LVDS differential data input. Channel E0 (even)
15	GND	GND
16	RXE1-	Negative LVDS differential data input. Channel E1 (even)
17	RXE1+	Positive LVDS differential data input. Channel E1 (even)
18	GND	GND
19	RXE2-	Negative LVDS differential data input. Channel E2 (even)
20	RXE2+	Positive LVDS differential data input. Channel E2 (even)
21	RXEC-	Negative LVDS differential clock input. (even)
22	RXEC+	Positive LVDS differential clock input. (even)
23	RXO3-	Negative LVDS differential data input. Channel O3(odd)
24	RXO3+	Positive LVDS differential data input. Channel O3 (odd)
25	GND	GND
26	NC	For LCD internal use only, Do not connect
27	NC	For LCD internal use only, Do not connect
28	NC	For LCD internal use only, Do not connect
29	Vcc	+5.0V power supply
30	Vcc	+5.0V power supply
31	Vcc	+5.0V power supply
32	GND	GND

Note (1) Connector Part No.: GS23302-0311R-7H (FOXCONN)

Note (2) User's connector Part No:

Mating Wire Cable Connector Part No.: FI-X30H(JAE) or FI-X30HL(JAE)

Mating FFC Cable Connector Part No.: 217007-013001 (P-TWO) or JF05X030-1 (JAE).

Note (3) The first pixel is odd.

Note (4) Input signal of even and odd clock should be the same timing.



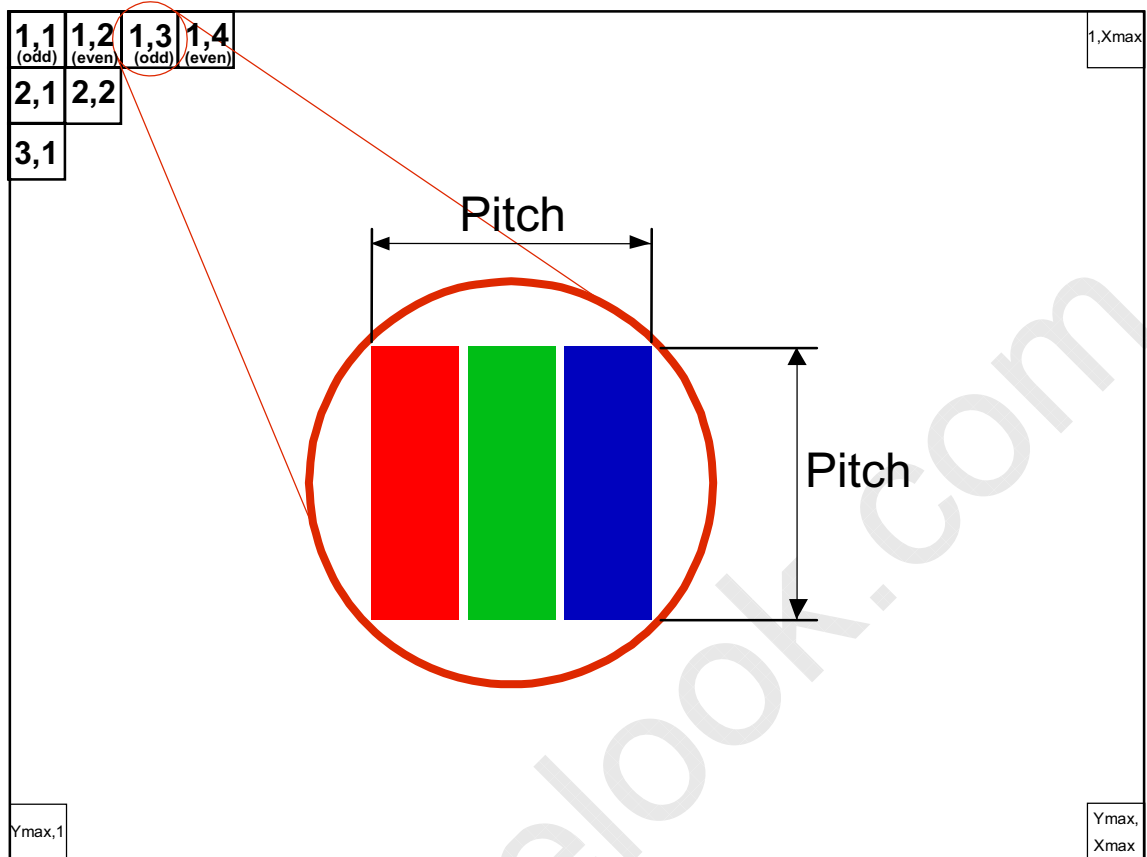

### 4.3 ELECTRICAL CHARACTERISTICS

#### 4.3.1 LCD ELETRONICS SPECIFICATION

Parameter	Symbol	Value			Unit	Note
		Min.	Typ.	Max.		
Power Supply Voltage	V <sub>CC</sub>	4.5	5	5.5	V	-
Ripple Voltage	V <sub>RP</sub>			300	mV	-
Rush Current	I <sub>RUSH</sub>			3	A	(2)
Power Supply Current	White		350	500	mA	(3)a
	Black		844	900	mA	(3)b
	Vertical Stripe		843	500	mA	(3)c
Power Consumption	PLCD		4.2	5.0	Watt	(4)
LVDS differential input voltage	V <sub>id</sub>	100		600	mV	(5)
LVDS common input voltage	V <sub>ic</sub>		1.2		V	(5)
Logic High Input Voltage	V <sub>IH</sub>			0.1	V	(5)
Logic Low Input Voltage	V <sub>IL</sub>	-0.1			V	(5)

Note (1) The ambient temperature is  $T_a = 25 \pm 2$  °C.

Note (2) Measurement Conditions:21

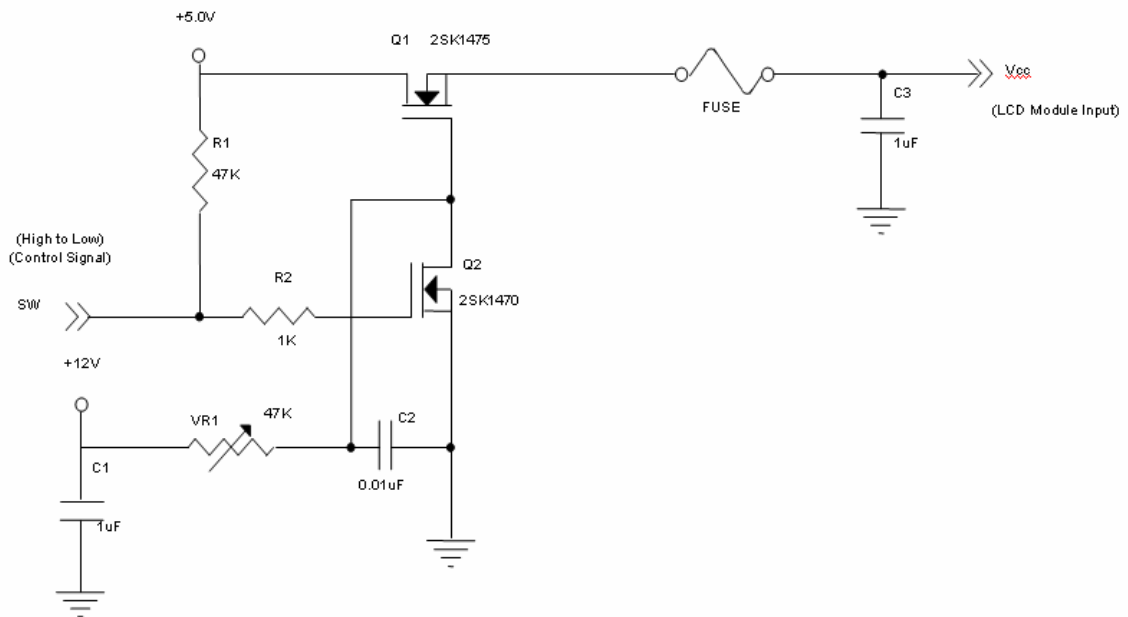

**Vcc rising time is 470μs**

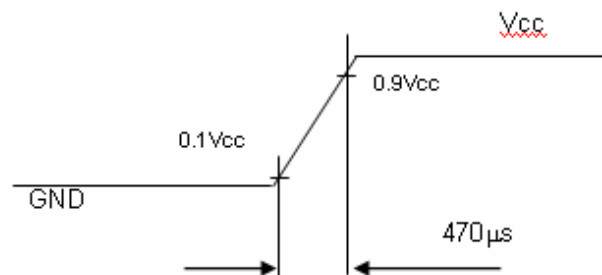

Note (3) The specified power supply current is under the conditions at  $V_{cc} = 5.0\text{ V}$ ,  $T_a = 25 \pm 2\text{ }^\circ\text{C}$ ,  $F_r = 75\text{ Hz}$ , whereas a power dissipation check pattern below is displayed.

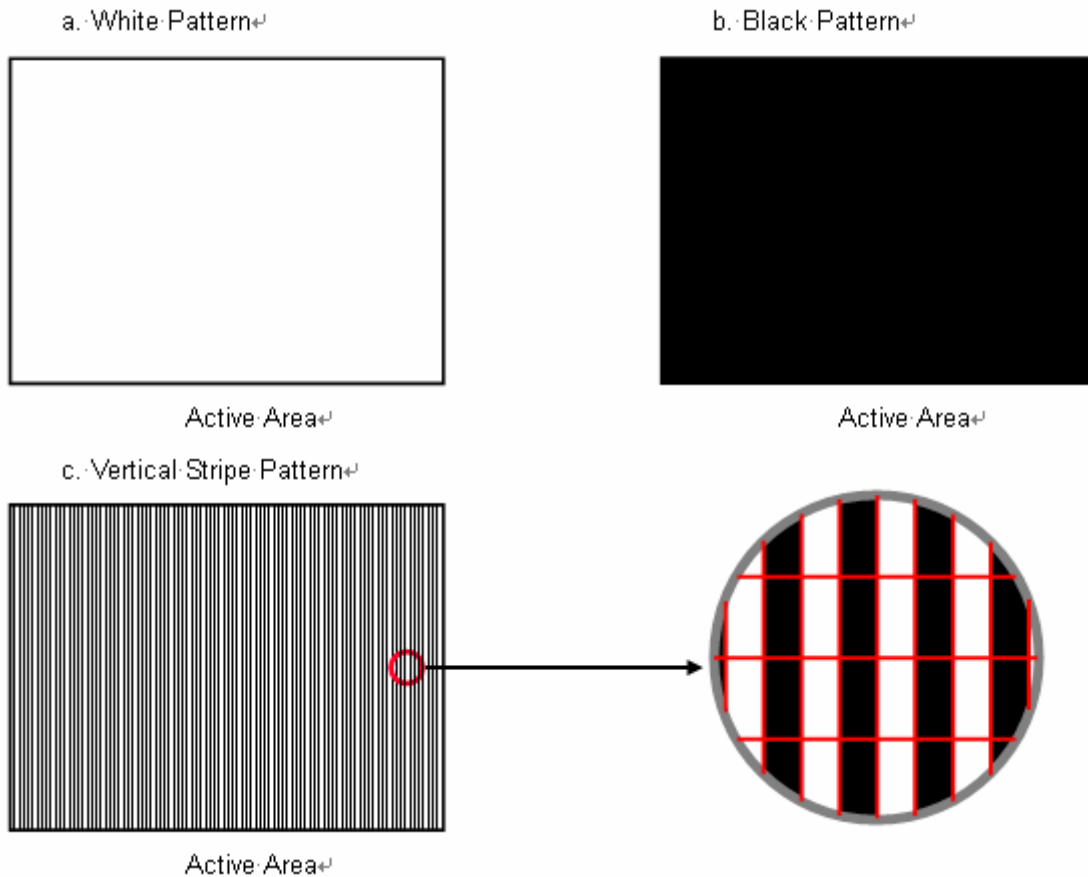

Note (4) The power consumption is specified at the pattern with the maximum current.

Note (5) VID waveform condition

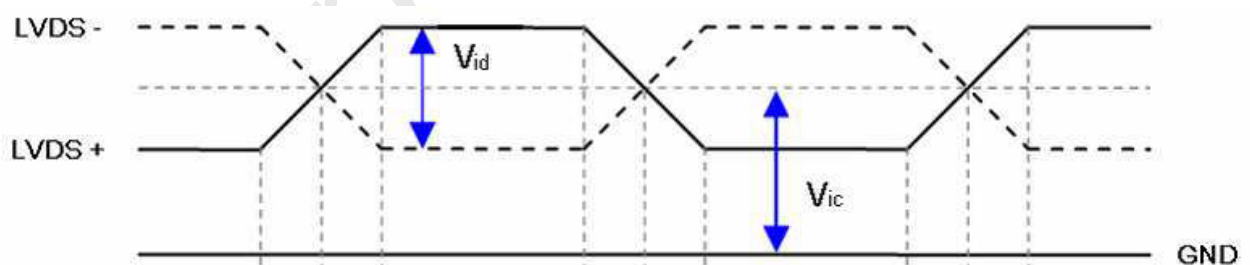

### 4.3.2 Vcc Power Dip Condition

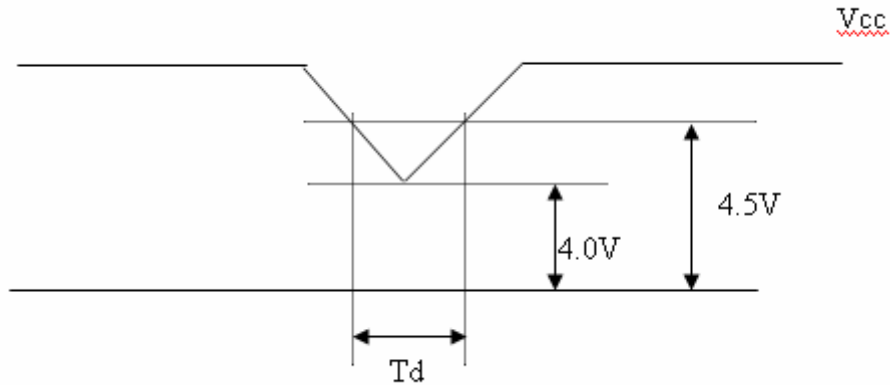

### 4.3.3 BACKLIGHT UNIT

Parameter	Symbol	Value			Unit	Note
		Min.	Typ.	Max.		
LED Light Bar Input Voltage Per Input Pin	VPIN	---	37.2	40.8	V	(1), Duty=100%, IPIN=65mA
LED Light Bar Current Per Input Pin	IPIN	---	65	69	mA	(1), (2) Duty=100%
LED Life Time	LLED	40000			Hrs	(3)
LED Light Bar Power Consumption	PBL	---	9.672	11.261	W	(1) Duty=100%, IPIN=65mA

Note (1) LED light bar input voltage and current are measured by utilizing a true RMS multimeter as shown below:

Note (2)  $PBL (Typ) = IPIN (Typ) \times VPIN (Typ) \times (4)$   $PBL (Max) = IPIN (Max) \times VPIN (Typ) \times (4)$   
input pins, LED light bar circuit is (12)Series, (4)Parallel.

Note (3) The lifetime of LED is defined as the time when LED packages continue to operate under the conditions at  $T_a = 25 \pm 2 \text{ }^\circ\text{C}$  and  $I = (65)\text{mA}$  (per chip) until the brightness becomes  $\leq 50\%$  of its original value.

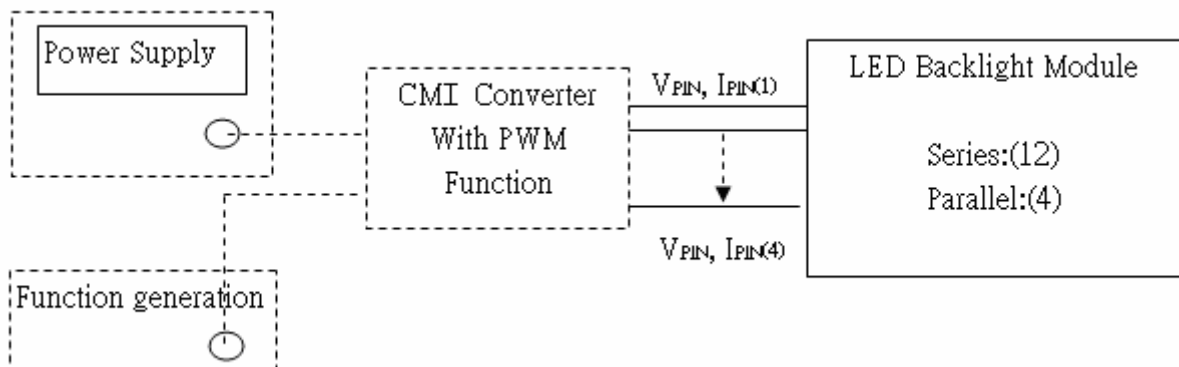

#### 4.3.4 LIGHTBAR Connector Pin Assignment

- (1) Connector: WM13-406-063N (FCN) or Compatible
- (2) L/B connector drawing

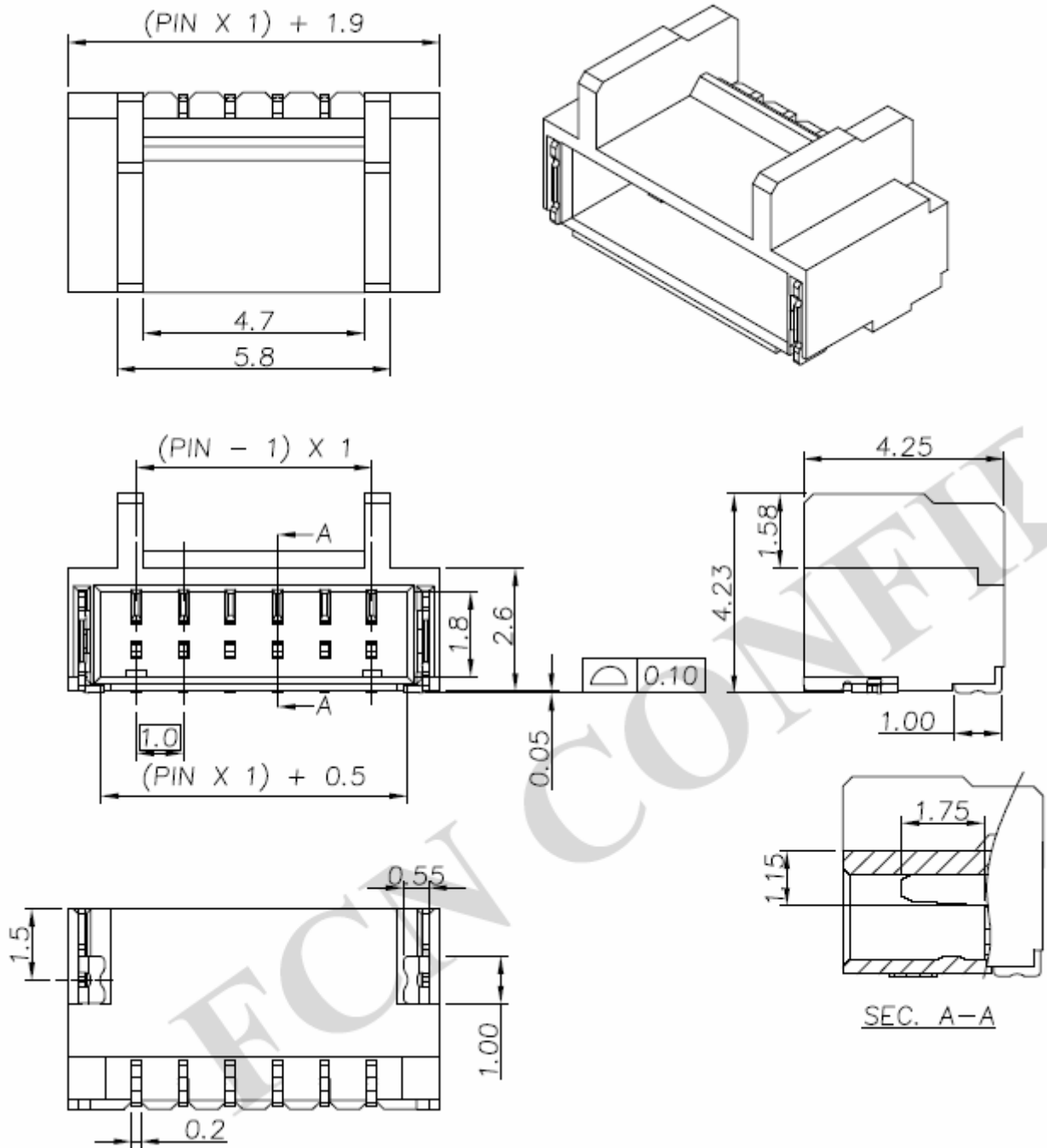

CN1

Pin number	Description
1	Cathode of LED string
2	Cathode of LED string
3	VLED
4	VLED
5	Cathode of LED string
6	Cathode of LED string

Note (1) User' s Mating Connector Part No.: CI1406SL000-NH (CviLux) or Compatible.

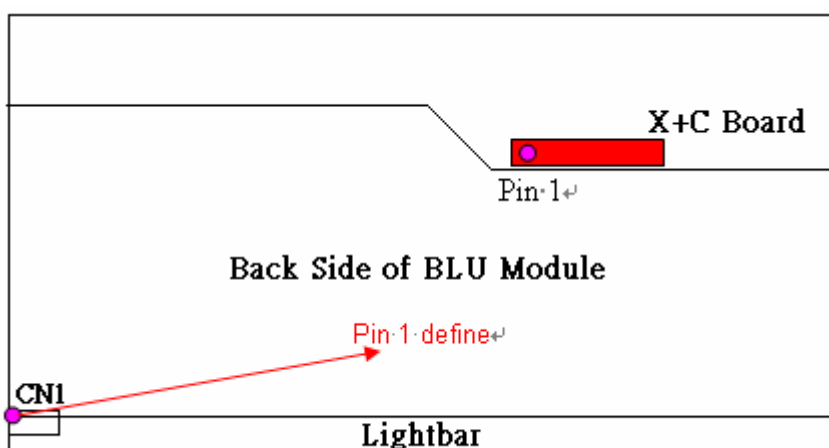

## 4.4 LVDS INPUT SIGNAL SPECIFICATIONS

### 4.4.1 LVDS DATA MAPPING TABLE

LVDS Channel O0	LVDS output	D7	D6	D4	D3	D2	D1	D0
	Data order	OG0	OR5	OR4	OR3	OR2	OR1	OR0
LVDS Channel O1	LVDS output	D18	D15	D14	D13	D12	D9	D8
	Data order	OB1	OB0	OG5	OG4	OG3	OG2	OG1
LVDS Channel O2	LVDS output	D26	D25	D24	D22	D21	D20	D19
	Data order	DE	NA	NA	OB5	OB4	OB3	OB2
LVDS Channel O3	LVDS output	D23	D17	D16	D11	D10	D5	D27
	Data order	NA	OB7	OB6	OG7	OG6	OR7	OR6
LVDS Channel E0	LVDS output	D7	D6	D4	D3	D2	D1	D0
	Data order	EG0	ER5	ER4	ER3	ER2	ER1	ER0
LVDS Channel E1	LVDS output	D18	D15	D14	D13	D12	D9	D8
	Data order	EB1	EB0	EG5	EG4	EG3	EG2	EG1
LVDS Channel E2	LVDS output	D26	D25	D24	D22	D21	D20	D19
	Data order	DE	NA	NA	EB5	EB4	EB3	EB2
LVDS Channel E3	LVDS output	D23	D17	D16	D11	D10	D5	D27
	Data order	NA	EB7	EB6	EG7	EG6	ER7	ER6

### 4.4.2 COLOR DATA INPUT ASSIGNMENT

The brightness of each primary color (red, green and blue) is based on the 8-bit gray scale data input for the color. The higher the binary input, the brighter the color. The table below provides the assignment of color versus data input.

Color		Data Signal																						
		Red								Green								Blue						
		R7	R6	R5	R4	R3	R2	R1	R0	G7	G6	G5	G4	G3	G2	G1	G0	B7	B6	B5	B4	B3	B2	B1
Basic Colors	Black	0	0	0	0	0	0	0	0	0	0	0	0	0	0	0	0	0	0	0	0	0	0	0
	Red	1	1	1	1	1	1	1	1	0	0	0	0	0	0	0	0	0	0	0	0	0	0	0
	Green	0	0	0	0	0	0	0	0	1	1	1	1	1	1	1	1	0	0	0	0	0	0	0
	Blue	0	0	0	0	0	0	0	0	0	0	0	0	0	0	0	0	1	1	1	1	1	1	1
	Cyan	0	0	0	0	0	0	0	0	1	1	1	1	1	1	1	1	1	1	1	1	1	1	1
	Magenta	1	1	1	1	1	1	1	1	0	0	0	0	0	0	0	0	1	1	1	1	1	1	1
	Yellow	1	1	1	1	1	1	1	1	1	1	1	1	1	1	1	1	0	0	0	0	0	0	0
	White	1	1	1	1	1	1	1	1	1	1	1	1	1	1	1	1	1	1	1	1	1	1	1
Gray Scale Of Red	Red(0) / Dark	0	0	0	0	0	0	0	0	0	0	0	0	0	0	0	0	0	0	0	0	0	0	
	Red(1)	0	0	0	0	0	0	0	1	0	0	0	0	0	0	0	0	0	0	0	0	0	0	
	Red(2)	0	0	0	0	0	0	1	0	0	0	0	0	0	0	0	0	0	0	0	0	0	0	
	⋮	⋮	⋮	⋮	⋮	⋮	⋮	⋮	⋮	⋮	⋮	⋮	⋮	⋮	⋮	⋮	⋮	⋮	⋮	⋮	⋮	⋮	⋮	
	⋮	⋮	⋮	⋮	⋮	⋮	⋮	⋮	⋮	⋮	⋮	⋮	⋮	⋮	⋮	⋮	⋮	⋮	⋮	⋮	⋮	⋮	⋮	
	Red(253)	1	1	1	1	1	1	0	1	0	0	0	0	0	0	0	0	0	0	0	0	0	0	
	Red(254)	1	1	1	1	1	1	1	0	0	0	0	0	0	0	0	0	0	0	0	0	0	0	
	Red(255)	1	1	1	1	1	1	1	1	0	0	0	0	0	0	0	0	0	0	0	0	0	0	
Gray Scale Of Green	Green(0) / Dark	0	0	0	0	0	0	0	0	0	0	0	0	0	0	0	0	0	0	0	0	0	0	
	Green(1)	0	0	0	0	0	0	0	0	0	0	0	0	0	0	1	0	0	0	0	0	0	0	
	Green(2)	0	0	0	0	0	0	0	0	0	0	0	0	0	1	0	0	0	0	0	0	0	0	
	⋮	⋮	⋮	⋮	⋮	⋮	⋮	⋮	⋮	⋮	⋮	⋮	⋮	⋮	⋮	⋮	⋮	⋮	⋮	⋮	⋮	⋮	⋮	
	⋮	⋮	⋮	⋮	⋮	⋮	⋮	⋮	⋮	⋮	⋮	⋮	⋮	⋮	⋮	⋮	⋮	⋮	⋮	⋮	⋮	⋮	⋮	
	Green(253)	0	0	0	0	0	0	0	0	1	1	1	1	1	1	0	1	0	0	0	0	0	0	
	Green(254)	0	0	0	0	0	0	0	0	1	1	1	1	1	1	1	0	0	0	0	0	0	0	
	Green(255)	0	0	0	0	0	0	0	0	1	1	1	1	1	1	1	1	0	0	0	0	0	0	
Gray Scale Of Blue	Blue(0) / Dark	0	0	0	0	0	0	0	0	0	0	0	0	0	0	0	0	0	0	0	0	0	0	
	Blue(1)	0	0	0	0	0	0	0	0	0	0	0	0	0	0	0	0	0	0	0	0	0	1	
	Blue(2)	0	0	0	0	0	0	0	0	0	0	0	0	0	0	0	0	0	0	0	0	0	1	
	⋮	⋮	⋮	⋮	⋮	⋮	⋮	⋮	⋮	⋮	⋮	⋮	⋮	⋮	⋮	⋮	⋮	⋮	⋮	⋮	⋮	⋮	⋮	
	⋮	⋮	⋮	⋮	⋮	⋮	⋮	⋮	⋮	⋮	⋮	⋮	⋮	⋮	⋮	⋮	⋮	⋮	⋮	⋮	⋮	⋮	⋮	
	Blue(253)	0	0	0	0	0	0	0	0	0	0	0	0	0	0	0	1	1	1	1	1	1	0	
	Blue(254)	0	0	0	0	0	0	0	0	0	0	0	0	0	0	0	1	1	1	1	1	1	0	
	Blue(255)	0	0	0	0	0	0	0	0	0	0	0	0	0	0	0	1	1	1	1	1	1	1	

Note (1) 0: Low Level Voltage, 1: High Level Voltage

### 4.5 DISPLAY TIMING SPECIFICATIONS

The input signal timing specifications are shown as the following table and timing diagram.

Signal	Item	Symbol	Min.	Typ.	Max.	Unit	Note
LVDS Clock	Frequency	Fc	45	54	69.3	MHz	-
	Period	Tc	14.43	18.52	22.22	ns	
	Input cycle to cycle jitter	T <sub>rdl</sub>	-0.02*TC	---	0.02*TC	ns	(1)
	Input Clock to data skew	TLVCCS	-0.02*TC	---	0.02*TC	ns	(2)
	Spread spectrum modulation range	F <sub>ckin_mod</sub>	0.97*FC	---	1.03*FC	MHz	(3)
	Spread spectrum modulation frequency	F <sub>SSM</sub>			200	KHz	
Vertical Display Term	Frame Rate	Fr	50	60	75	Hz	
	Total	Tv	1044	1066	1100	Th	Tv=Tvd+Tvb-
	Active Display	Tvd		1024		Th	-
	Blank	Tvb	20	42		Th	-
Horizontal Display Term	Total	Th	790	844	880	Tc	Th=Thd+Thb
	Active Display	Thd		640		Tc	-
	Blank	Thb	150	204		Tc	-

Note: Because this module is operated by DE only mode, Hsync and Vsync input signals are ignored.

#### INPUT SIGNAL TIMING DIAGRAM

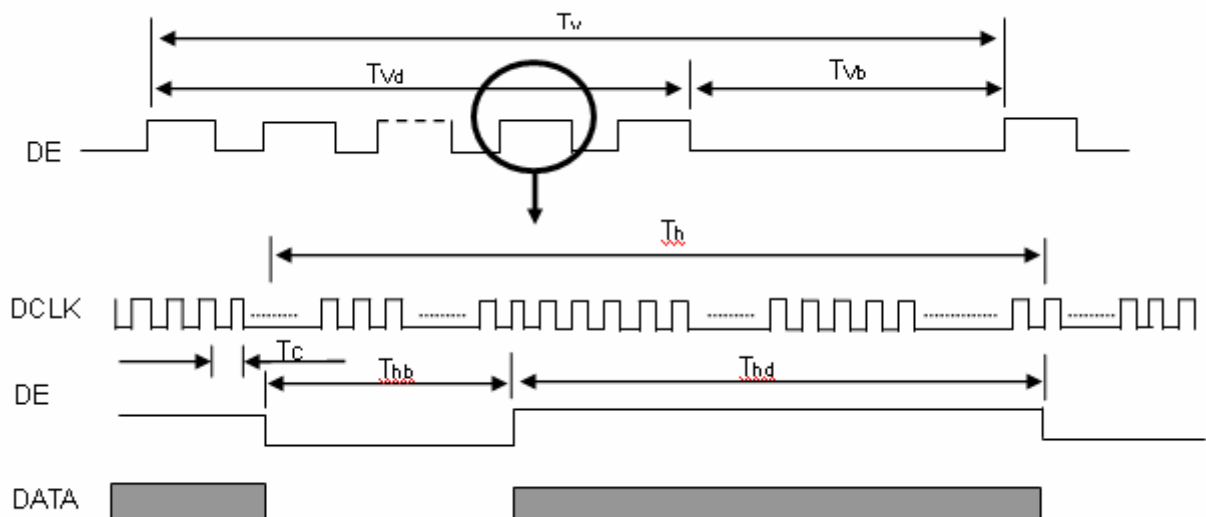



Note (1) The input clock cycle-to-cycle jitter is defined as below figures.  $Trcl = |T_1 - T_1'|$

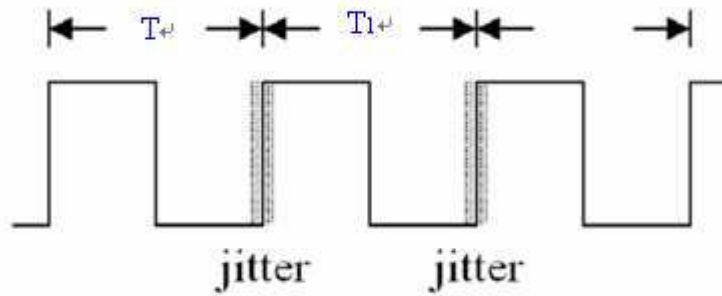

Note (2) Input Clock to data skew is defined as below figures.

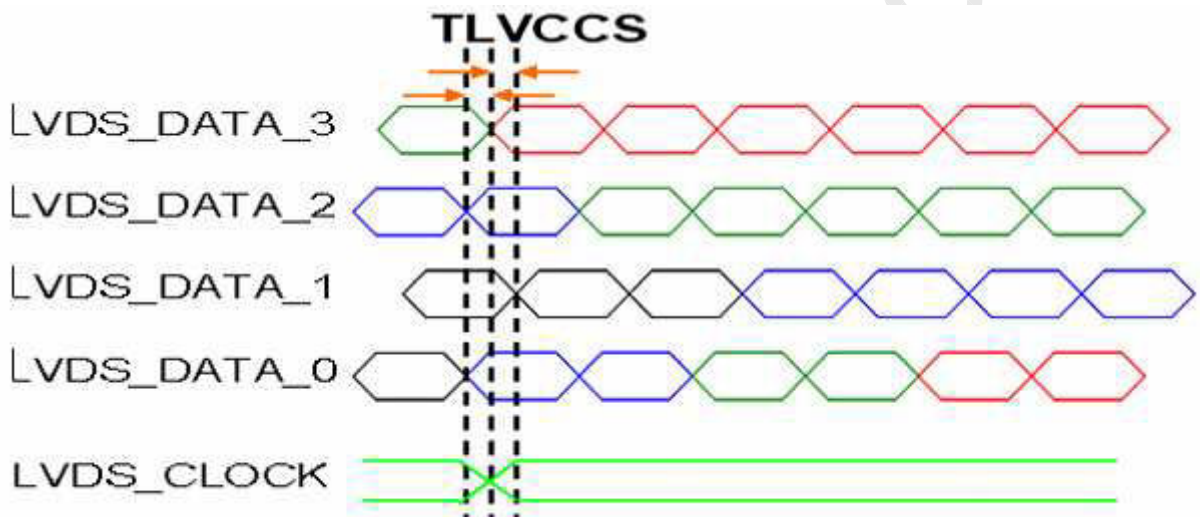

Note (3) The SSCG (Spread spectrum clock generator) is defined as below figures.

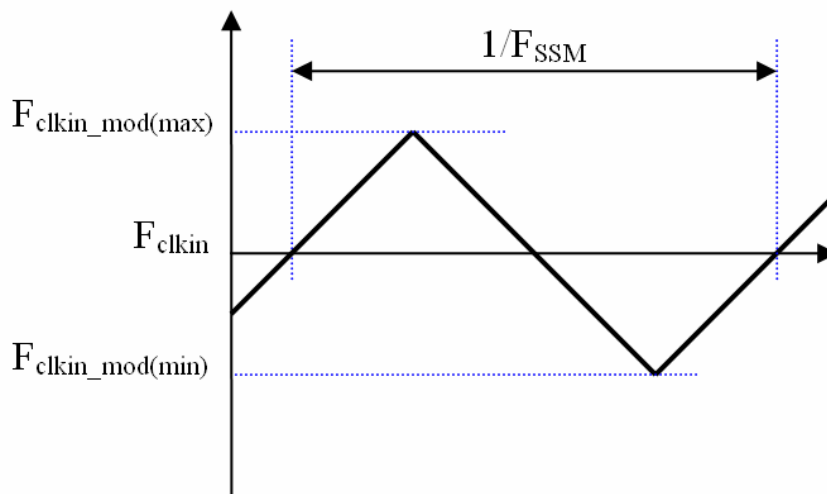

#### 4.6 POWER ON/OFF SEQUENCE

The power sequence specifications are shown as the following table and diagram.

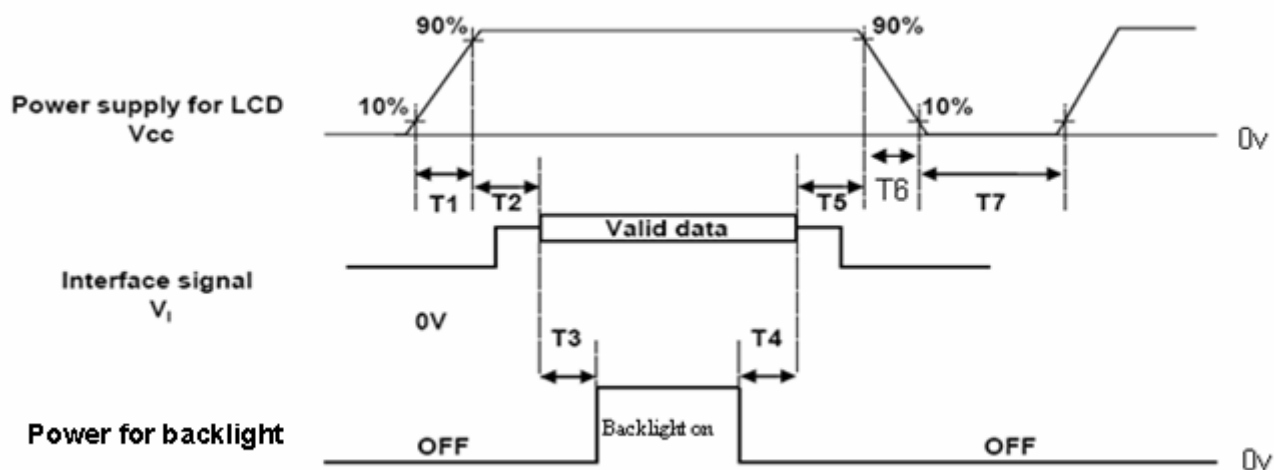

Timing Specifications:

Parameters	Values			Units
	Min	Typ.	Max	
T1	0.1		10	ms
T2	0	30	50	ms
T3	200	250		ms
T4	100	250		ms
T5		20	50	ms
T6	0.1		50	ms
T7	1000			ms

Note (1) The supply voltage of the external system for the module input should be the same as the definition of Vcc.

Note (2) When the backlight turns on before the LCD operation of the LCD turns off, the display may momentarily become abnormal screen.

Note (3) In case of VCC = off level, please keep the level of input signals on the low or keep a high impedance.

Note (4) T4 should be measured after the module has been fully discharged between power off and on period.

Note (5) Interface signal shall not be kept at high impedance when the power is on.

Note (6) CMI won't take any responsibility for the products which are damaged by the customers not following the Power Sequence.

Note (7) There might be slight electronic noise when LCD is turned off (even backlight unit is also off). To avoid this symptom, we suggest "Vcc falling timing" to follow "t6 spec".

## 5. OPTICAL CHARACTERISTICS

### 5.1 TEST CONDITIONS

Item	Symbol	Value	Unit
Ambient Temperature	Ta	25±2	°C
Ambient Humidity	Ha	50±10	%RH
Supply Voltage	V <sub>CC</sub>	12	V
Input Signal	According to typical value in "3. ELECTRICAL CHARACTERISTICS"		
LED Light Bar Input Current Per Input Pin	I <sub>PIN</sub>	65±1.9	mA <sub>DC</sub>
PWM Duty Ratio	D	100	%
LED Light Bar Test Converter	TEST01001 T2-D1		

### 5.2 OPTICAL SPECIFICATIONS

The relative measurement methods of optical characteristics are shown in 5.2. The following items should be measured under the test conditions described in 5.1 and stable environment shown in Note (5).

Item	Symbol	Condition	Min.	Typ.	Max.	Unit	Note	
Color Chromaticity (CIE 1931)	Red	Rx	$\theta_x=0^\circ, \theta_y=0^\circ$ <b>CS-2000</b> <b>R=G=B=255</b> <b>Gray scale</b>	Typ - 0.03	TBD	Typ + 0.03	-	(1), (5)
		Ry			TBD			
	Green	Gx			TBD			
		Gy			TBD			
	Blue	Bx			TBD			
		By			TBD			
	White	Wx			0.313			
		Wy			0.329			
Center Luminance of White (Center of Screen)	L <sub>c</sub>		200	250	-	cd/m <sup>2</sup>	(4), (5)	
Contrast Ratio	CR		700	1000	-	-	(2), (5)	
Response Time	T <sub>R</sub>	$\theta_x=0^\circ, \theta_y=0^\circ$	-	1	4	ms	(3)	
	T <sub>F</sub>		-	4	6			
White Variation	W	$\theta_x=0^\circ, \theta_y=0^\circ$	75			%	(5), (6)	
Viewing Angle	Horizontal	$\theta_x- + \theta_x+$	CR ≥ 10	150	170	-	Deg.	(1), (5)
	Vertical			$\theta_y- + \theta_y+$	140	160		
Viewing Angle	Horizontal	$\theta_x- + \theta_x+$	CR ≥ 5	160	178	---	Deg.	(1), (5)
	Vertical			$\theta_y- + \theta_y+$	150	170		

Note (1) Definition of Viewing Angle ( $\theta_x, \theta_y$ ):

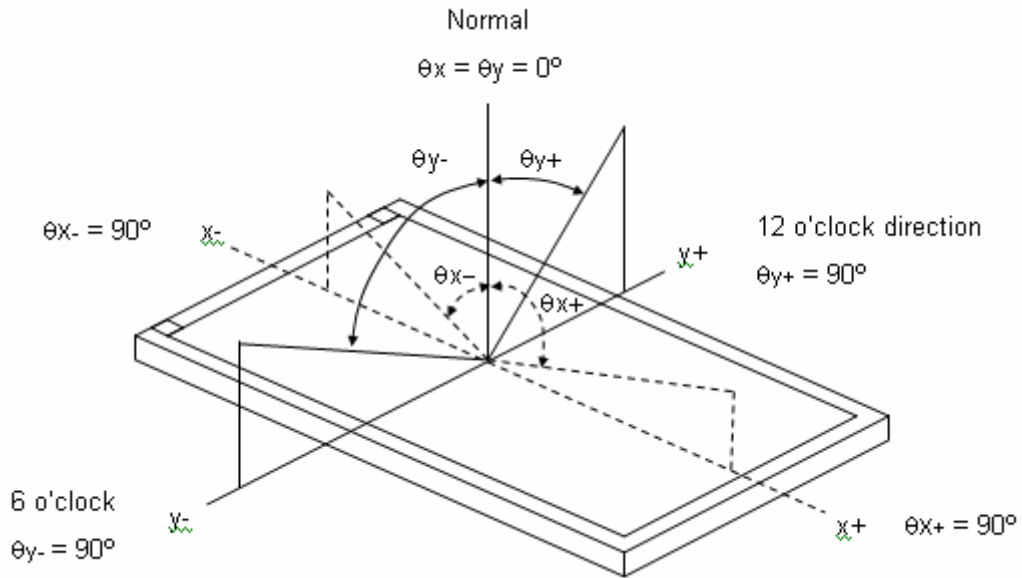

Note (2) Definition of Contrast Ratio (CR):

The contrast ratio can be calculated by the following expression.

$$\text{Contrast Ratio (CR)} = L_{255} / L_0$$

L255: Luminance of gray level 255

L 0: Luminance of gray level 0

$$\text{CR} = \text{CR} (5)$$

CR (X) is corresponding to the Contrast Ratio of the point X at Figure in Note (6).

Note (3) Definition of Response Time ( $T_R, T_F$ ):

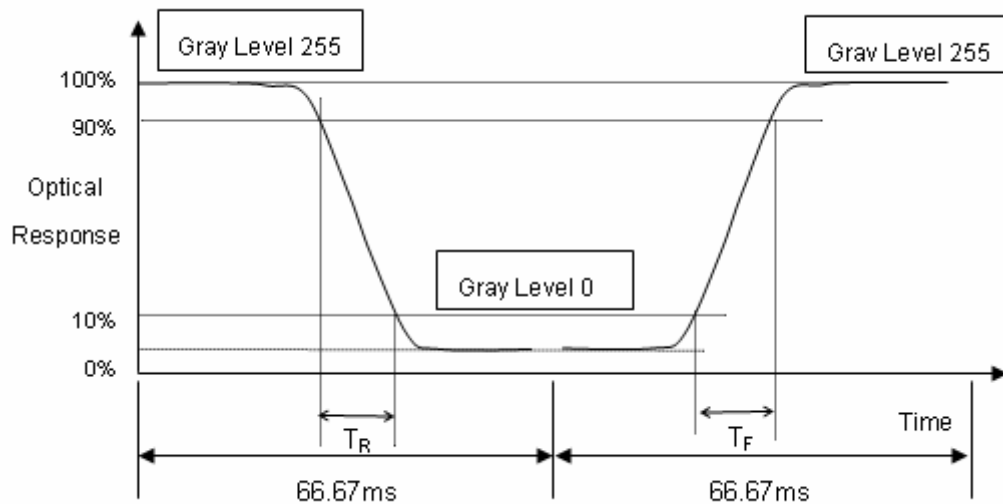

Note (4) Definition of Luminance of White ( $L_c$ ):

Measure the luminance of gray level 255 at center point

$$L_c = L(5)$$

$L(x)$  is corresponding to the luminance of the point X at Figure in Note (6).

Note (5) Measurement Setup:

The LCD module should be stabilized at given temperature for 40 minutes to avoid abrupt temperature change during measuring. In order to stabilize the luminance, the measurement should be executed after lighting Backlight for 40 minutes in a windless room.

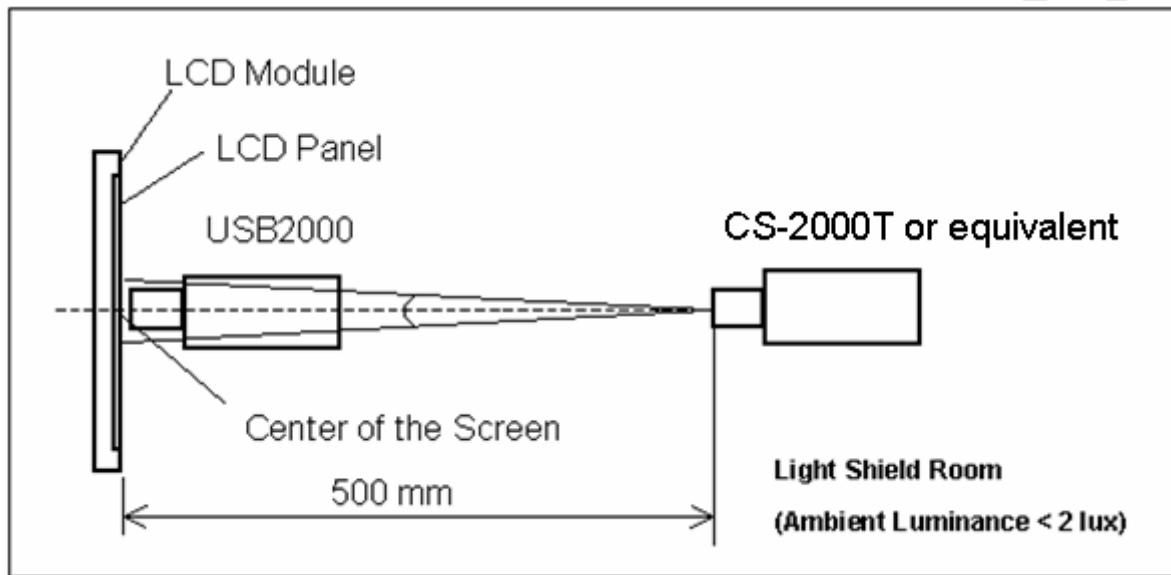

Note (6) Definition of White Variation ( $\delta W$ ):

Measure the luminance of gray level 255 at 9 points

$$\delta W = (\text{Minimum } [L(1) \sim L(9)] / \text{Maximum } [L(1) \sim L(9)]) * 100\%$$

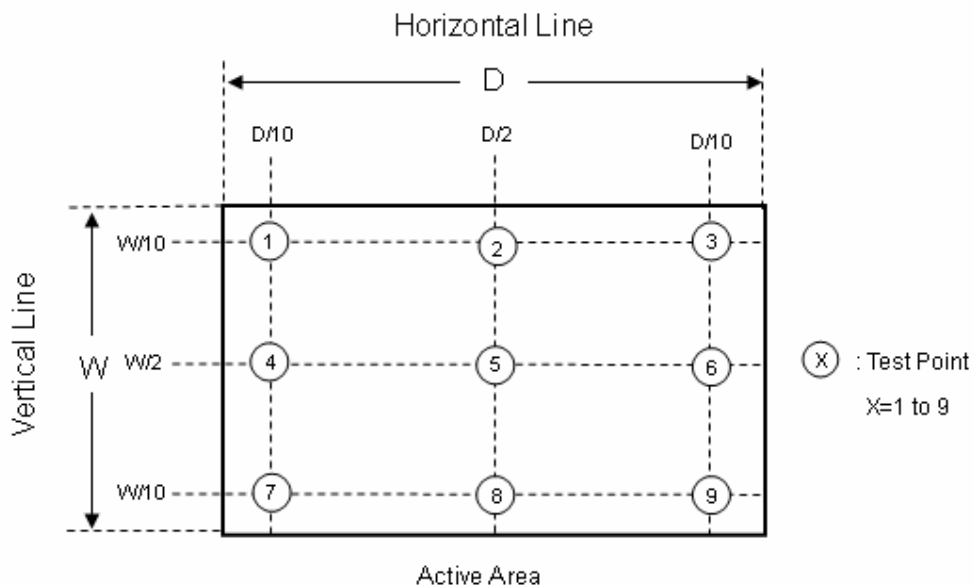

6. RELIABILITY TEST ITEM

Items	Required Condition	Note
Temperature Humidity Bias (THB)	Ta= 50°C , 80%RH, 240hours	
High Temperature Operation (HTO)	Ta= 50°C , 240hours	
Low Temperature Operation (LTO)	Ta= 0°C , 240hours	
High Temperature Storage (HTS)	Ta= 60°C , 240hours	
Low Temperature Storage (LTS)	Ta= -20°C , 240hours	
Vibration Test (Non-operation)	Acceleration: 1.5 G Wave: Half-sine Frequency: 10 - 300 Hz Sweep: 30 Minutes each Axis (X, Y, Z)	
Shock Test (Non-operation)	Acceleration: 50 G Wave: Half-sine Active Time: 11 ms Direction : ± X, ± Y, ± Z.(one time for each Axis)	
Thermal Shock Test (TST)	-20°C/30min , 60°C / 30min , 100 cycles	
On/Off Test	25°C , On/10sec , Off /10sec , 30,000 cycles	
ESD (Electro Static Discharge)	Contact Discharge: ± 8KV, 150pF(330Ω)	
	Air Discharge: ± 15KV, 150pF(330Ω)	
Altitude Test	Operation:10,000 ft / 24hours Non-Operation:30,000 ft / 24hours	

Note (1) criteria : Normal display image with no obvious non-uniformity and no line defect.

Note (2) Evaluation should be tested after storage at room temperature for more than two hour

Note (3) At testing Vibration and Shock, the fixture in holding the module has to be hard and rigid enough so that the module would not be twisted or bent by the fixture.

The fixing condition is shown as below:

At Room Temperature

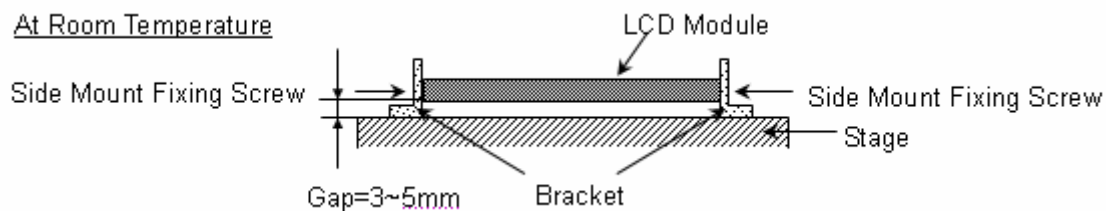

## 7. PACKING

### 7.1 PACKING SPECIFICATIONS

- (1) 7 LCD modules / 1 Box
- (2) Box dimensions: 448(L) X 322 (W) X 390(H) mm
- (3) Weight: approximately: 12kg (7 modules per box)

### 7.2 PACKING METHOD

(1) Carton Packing should have no failure in the following reliability test items.

Test Item	Test Conditions	Note
Vibration	ISTA STANDARD Random, Frequency Range: 1.47Grms X,Y,Z three axes (30min /axis), Frequency: 5Hz(0.015G <sup>2</sup> /Hz), 100Hz(0.015G <sup>2</sup> /Hz), 200Hz(0.0037G <sup>2</sup> /Hz)	Non Operation
Dropping Test	1 Corner , 3 Edge, 6 Face, 60cm	Non Operation

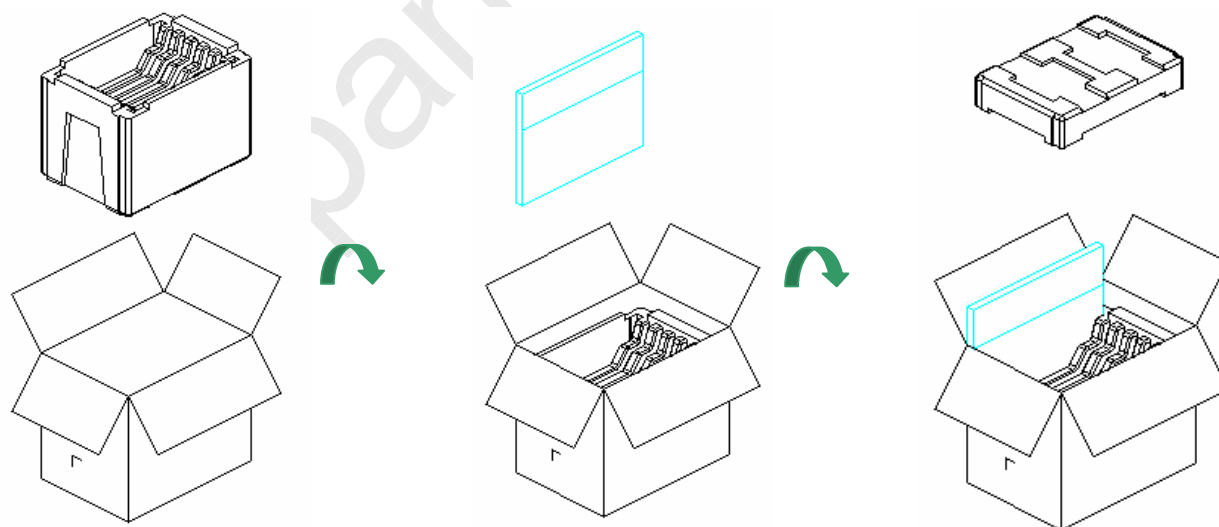
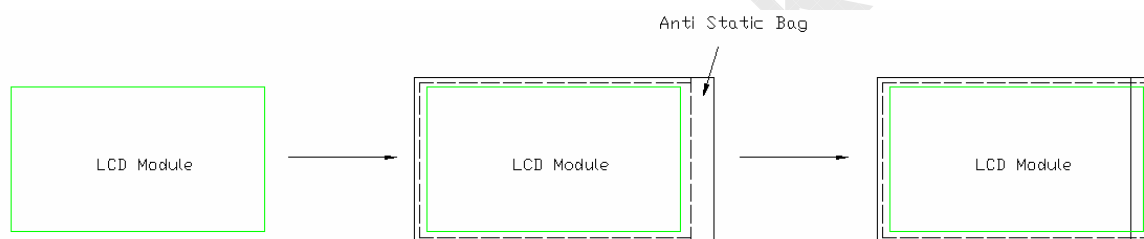

Figure. 7-1 Packing method

7.3 PALLET

For Sea/Land Transportation(20ft/40ft Container)

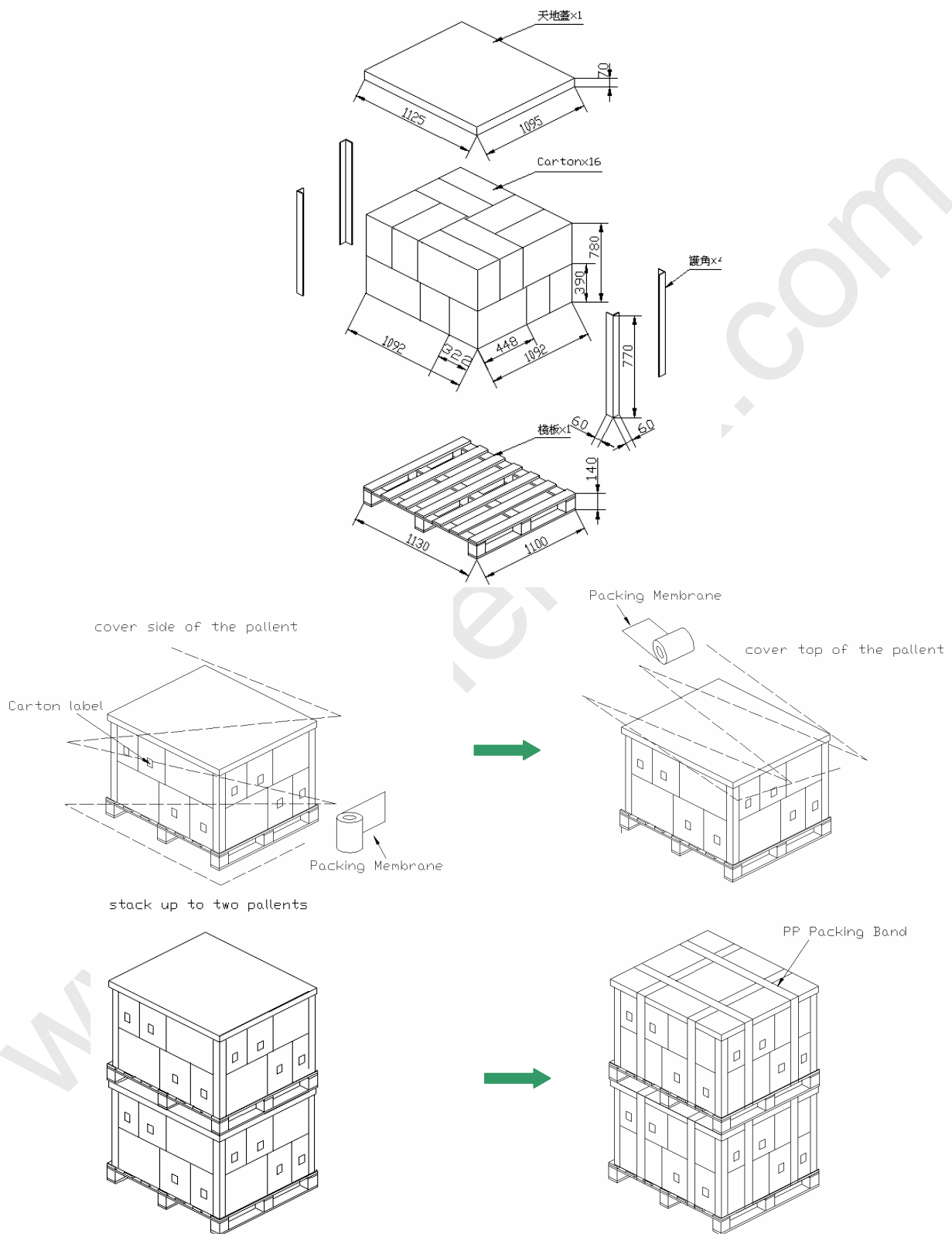

Figure. 7-2 Packing method



### 8. CMI MODULE LABEL

The barcode nameplate is pasted on each module as illustration, and its definitions are as following explanation.



(a) Model Name: M170EGE-L20

(b) CMI barcode definition:

Serial ID: Z<sub>1</sub> Z<sub>2</sub> Z<sub>3</sub> Z<sub>4</sub> Z<sub>5</sub> Z<sub>6</sub>--Z<sub>7</sub>--Z<sub>8</sub> Z<sub>9</sub> Z<sub>10</sub> Z<sub>11</sub> Z<sub>12</sub>

Code	Meaning	Description
Z <sub>1</sub>	internal use	-
Z <sub>2</sub> Z <sub>3</sub> Z <sub>4</sub>	Year ,Month ,Date	Year: 0~9, 2010=0, 2011=1, 2012=2, 2013=3... Month: 1~12=1, 2, 3, ~, 9, A, B, C Day: 1~31=1, 2, 3, ~, 9, A, B, C, ~, W, X, Y, exclude I, O, and U.
Z <sub>5</sub>	internal use	-
Z <sub>6</sub>	internal use	-
Z <sub>7</sub>	Code of grade	G: 1, 2, 3, 5, E
Z <sub>8</sub> Z <sub>9</sub> Z <sub>10</sub> Z <sub>11</sub> Z <sub>12</sub>	Serial No	Module manufacture sequence no

(c) Customer's barcode definition:

Serial ID: CM-H0E20-X-X-X-XX-L-XX-L-YMD-NNNN

Code	Meaning	Description
CM	Supplier code	CMI=CM
H0E20	Model number	M170EGE-L20= H0E20
X	Revision code	Non ZBD: 1,2,~,8,9 / ZBD: A~Z
X	Source driver IC code	Century=1, CLL=2, Demos=3, Epson=4, Fujitsu=5, Himax=6, Hitachi=7, Hynix=8, LDI=9, Matsushita=A, NEC=B, Novatec=C, OKI=D, Philips=E, Renasas=F, Samsung=G, Sanyo=H, Sharp=I, TI=J, Topro=K, Toshiba=L, Windbond=M, ILITEK=Q, Fiti=Y, None IC =Z
X	Gate driver IC code	
XX	Cell location	Tainan Taiwan=TN, Ningbo China=CN, Hsinchu Taiwan=SC
L	Cell line #	1,2,~,9,A,B,~,Y,Z
XX	Module location	Tainan, Taiwan=TN ; Ningbo China=NP, Shenzhen China=SH
L	Module line #	1,2,~,9,A,B,~,Y,Z
YMD	Year, month, day	Year: 0~9, 2001=1, 2002=2, 2003=3...2010=0, 2011=1, 2012=2... Month: 1~12=1, 2, 3, ~, 9, A, B, C Day: 1~31=1, 2, 3, ~, 9, A, B, C, ~, T, U, V
NNNN	Serial number	By LCD supplier

(d) FAB ID(UL Factory ID):

Region	Factory ID
TWCM I	GEMN
NBCMI	LEOO
NBCME	CANO
NHCM I	CAPG

## 9. PRECAUTIONS

### 9.1 ASSEMBLY AND HANDLING PRECAUTIONS

- (1) Do not apply rough force such as bending or twisting to the module during assembly.
- (2) To assemble or install module into user's system can be only in clean working areas. The dust and oil may cause electrical short or worsen the polarizer.
- (3) It's not permitted to have pressure or impulse on the module because the LCD panel and Backlight will be damaged.
- (4) Always follow the correct power sequence when LCD module is connecting and operating. This can prevent damage to the CMOS LSI chips during latch-up.
- (5) Do not pull the I/F connector in or out while the module is operating.
- (6) Do not disassemble the module.
- (7) Use a soft dry cloth without chemicals for cleaning, because the surface of polarizer is very soft and easily scratched.
- (8) It is dangerous that moisture come into or contacted the LCD module, because moisture may damage LCD module when it is operating.

- (9) High temperature or humidity may reduce the performance of module. Please store LCD module within the specified storage conditions.
- (10) When ambient temperature is lower than 10°C may reduce the display quality. For example, the response time will become slowly.

## 9.2 STORAGE PRECAUTIONS

- (1) Do not leave the module in high temperature, and high humidity for a long time. It is highly recommended to store the module with temperature from 0°C to 35°C and relative humidity of less than 70%
- (2) Do not store the TFT – LCD module in direct sunlight
- (3) The module should be stored in dark place. It is prohibited to apply sunlight or fluorescent light in storing

## 9.3 OPERATION PRECAUTIONS

- (1) The LCD product should be operated under normal condition.  
Normal condition is defined as below :  
Temperature : 20±15°C  
Humidity: 65±20%  
Display pattern : continually changing pattern(Not stationary)
- (2) If the product will be used in extreme conditions such as high temperature, high humidity, high altitude, display pattern or operation time etc... It is strongly recommended to contact CMI for application engineering advice. Otherwise, its reliability and function may not be guaranteed.

## 9.4 SAFETY PRECAUTIONS

- (1) If the liquid crystal material leaks from the panel, it should be kept away from the eyes or mouth. In case of contact with hands, skin or clothes, it has to be washed away thoroughly with soap.
- (2) After the module's end of life, it is not harmful in case of normal operation and storage.

## 9.5 SAFETY STANDARDS

The LCD module should be certified with safety regulations as follows:

- (1) UL60950-1 or updated standard.
- (2) IEC60950-1 or updated standard.

## 9.6 OTHER

When fixed patterns are displayed for a long time, remnant image is likely to occur.

## Appendix. OUTLINE DRAWING

I. ME Drawing

(1) Front view

