

- Tentative Specification
- Preliminary Specification
- Approval Specification

**MODEL NO.: V420H2**  
**SUFFIX: LE3**

<b>Customer:</b>	
<b>APPROVED BY</b>	<b>SIGNATURE</b>
Name / Title _____	_____
<b>Note</b>	
_____	
Please return 1 copy for your confirmation with your signature and comments.	

Approved By	Checked By	Prepared By
Chao-Chun Chung	Ken Wu	Peggi Chiu

CONTENTS

<b>1. GENERAL DESCRIPTION</b> .....	5
<b>1.1 OVERVIEW</b> .....	5
<b>1.2 FEATURES</b> .....	5
<b>1.3 APPLICATION</b> .....	5
<b>1.4 GENERAL SPECIFICATIONS</b> .....	5
<b>1.5 MECHANICAL SPECIFICATIONS</b> .....	5
<b>2.1 ABSOLUTE RATINGS OF ENVIRONMENT</b> .....	6
<b>2.2 PACKAGE STORAGE</b> .....	7
<b>2.3 ELECTRICAL ABSOLUTE RATINGS</b> .....	7
<b>2.3.1 TFT LCD MODULE</b> .....	7
<b>2.3.2 BACKLIGHT UNIT</b> .....	7
<b>3. ELECTRICAL CHARACTERISTICS</b> .....	8
<b>3.1 TFT LCD MODULE</b> .....	8
<b>3.2 BACKLIGHT CONVERTER UNIT</b> .....	11
<b>3.2.1 LED LIGHT BARCHARACTERISTICS</b> (Ta = 25 ± 2 °C).....	11
<b>3.2.2 CONVERTER CHARACTERISTICS</b> (Ta = 25 ± 2 °C).....	11
<b>3.2.3 CONVERTER INTERFACE CHARACTERISTICS</b> .....	12
<b>4. BLOCK DIAGRAM OF INTERFACE</b> .....	14
<b>4.1 TFT LCD MODULE</b> .....	14
<b>5. INTERFACE PIN CONNECTION</b> .....	15
<b>5.1 TFT LCD MODULE</b> .....	15
<b>5.2 BACKLIGHT UNIT</b> .....	19
<b>5.3 CONVERTER UNIT</b> .....	20
<b>5.4 BLOCK DIAGRAM OF INTERFACE</b> .....	21
<b>5.5 LVDS INTERFACE</b> .....	23
<b>6. INTERFACE TIMING</b> .....	26
<b>6.1 INPUT SIGNAL TIMING SPECIFICATIONS</b> .....	26
<b>6.2 POWER ON/OFF SEQUENCE</b> .....	28
<b>6.2 POWER ON/OFF SEQUENCE</b> .....	29
<b>7. OPTICAL CHARACTERISTICS</b> .....	30
<b>7.1 TEST CONDITIONS</b> .....	30
<b>7.2 OPTICAL SPECIFICATIONS</b> .....	31
<b>8. DEFINITION OF LABELS</b> .....	34
<b>8.1 CMO MODULE LABEL</b> .....	34
<b>9. PACKAGING</b> .....	35
<b>9.1 PACKING SPECIFICATIONS</b> .....	35
<b>9.2 PACKING METHOD</b> .....	35

<b>10. PRECAUTIONS</b> .....	37
<b>10.1 ASSEMBLY AND HANDLING PRECAUTIONS</b> .....	37
<b>10.2 SAFETY PRECAUTIONS</b> .....	37
<b>11. MECHANICAL CHARACTERISTICS</b> .....	38

REVISION HISTORY

Version	Date	Page(New)	Section	Description
Ver. 2.0	Jul 07, 2010	All	All	The specification was first issued.

## 1. GENERAL DESCRIPTION

### 1.1 OVERVIEW

V420H2- LE3 is a 42" TFT Liquid Crystal Display module with LED Backlight and 4ch-LVDS interface. This module supports 1920 x 1080 Full HDTV format and can display 1.07G colors ( 8-bit+ FRC). The converter module for backlight is built-in.

### 1.2 FEATURES

- High brightness (450 nits)
- Ultra-high contrast ratio (6000:1)
- Faster response time (gray to gray average 5.5 ms)
- High color saturation NTSC 72% (72%)
- Ultra wide viewing angle : 176(H)/176(V) (CR $\geq$ 20) with Super MVA technology
- DE (Data Enable) only mode
- LVDS (Low Voltage Differential Signaling) interface
- Color reproduction (nature color)
- Low color shift function

### 1.3 APPLICATION

- TFT LCD TVs
- Multi-Media Display

### 1.4 GENERAL SPECIFICATIONS

Item	Specification	Unit	Note
Active Area	930.24 (H) x 523.26 (V) (42" diagonal)	mm	(1)
Bezel Opening Area	937.24 (H) x 530.26 (V)	mm	
Driver Element	a-si TFT active matrix	-	
Pixel Number	1920 x R.G.B. x 1080	pixel	
Pixel Pitch (Sub Pixel)	0.1615 (H) x 0.4845 (V)	mm	
Pixel Arrangement	RGB vertical stripe	-	
Display Colors	1.07G	color	
Display Operation Mode	Transmissive mode / Normally Black	-	
Surface Treatment	Anti-Glare Coating (Haze 11%) Hard Coating (3H)	-	

### 1.5 MECHANICAL SPECIFICATIONS

Item	Min.	Typ.	Max.	Unit	Note
Module Size	Horizontal(H)	-	973.24	-	mm (1)
	Vertical(V)	-	566.26	-	mm (1)
	Depth(D)	-	10.8	-	mm
	Depth(D)	24.6	25.6	26.6	mm
Weight		8150			

Note (1) Please refer to the attached drawings for more information of front and back outline dimensions.

**2. ABSOLUTE MAXIMUM RATINGS**

**2.1 ABSOLUTE RATINGS OF ENVIRONMENT**

Item	Symbol	Value		Unit	Note
		Min.	Max.		
Storage Temperature	T <sub>ST</sub>	-20	+60	°C	(1)
Operating Ambient Temperature	T <sub>OP</sub>	0	+50	°C	(1), (2)
Shock (Non-Operating)	S <sub>NOF</sub>	-	35	G	(3), (5)
Vibration (Non-Operating)	V <sub>NOF</sub>	-	1.0	G	(4), (5)

Note (1) Temperature and relative humidity range is shown in the figure below.

- (a) 90 %RH Max. (Ta ≤ 40 °C).
- (b) Wet-bulb temperature should be 39 °C Max. (Ta > 40 °C).
- (c) No condensation.

Note (2) The maximum operating temperature is based on the test condition that the surface temperature of display area is less than or equal to 65 °C with LCD module alone in a temperature controlled chamber. Thermal management should be considered in final product design to prevent the surface temperature of display area from being over 65 °C. The range of operating temperature may degrade in case of improper thermal management in final product design.

Note (3) 11 ms, half sine wave, 1 time for ± X, ± Y, ± Z.

Note (4) 10 ~ 200 Hz, 10 min, 1 time each X, Y, Z.

Note (5) At testing Vibration and Shock, the fixture in holding the module has to be hard and rigid enough so that the module would not be twisted or bent by the fixture.

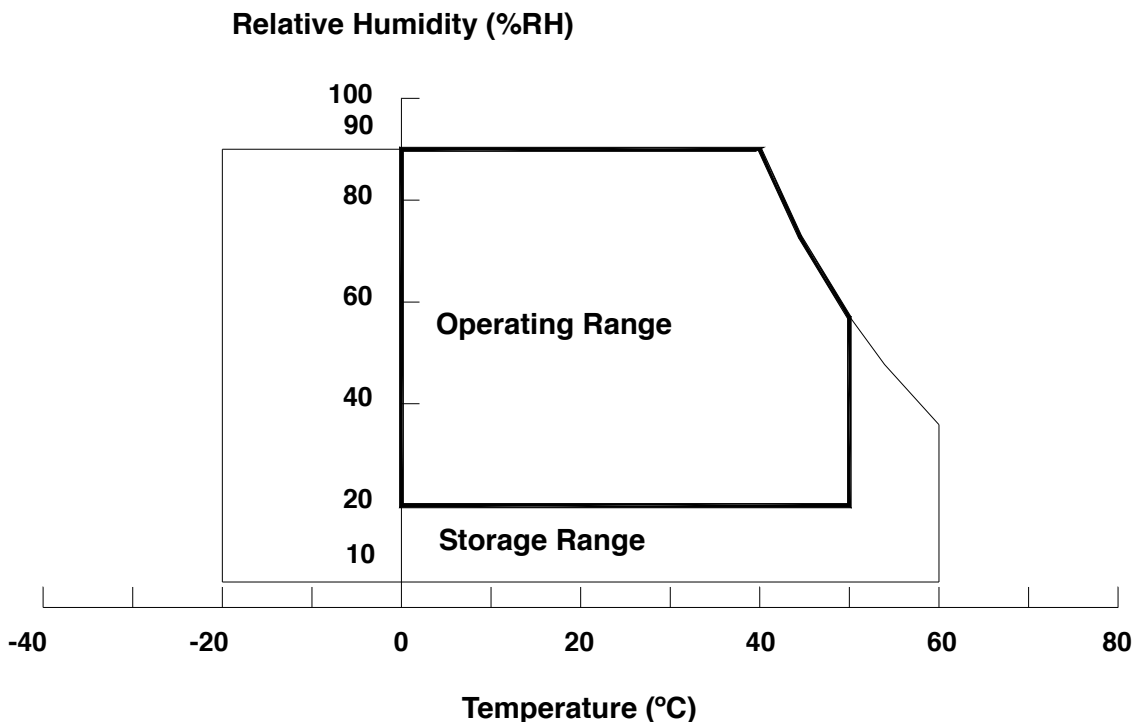

## 2.2 PACKAGE STORAGE

When storing modules as spares for a long time, the following precaution is necessary.

- (a) Do not leave the module in high temperature, and high humidity for a long time. It is highly recommended to store the module with temperature from 0 to 35°C at normal humidity without condensation.
- (b) The module shall be stored in dark place. Do not store the TFT-LCD module in direct sunlight or fluorescent light.

## 2.3 ELECTRICAL ABSOLUTE RATINGS

### 2.3.1 TFT LCD MODULE

Item	Symbol	Value		Unit	Note
		Min.	Max.		
Power Supply Voltage	V <sub>CC</sub>	-0.3	13.5	V	
Input Signal Voltage	V <sub>IN</sub>	-0.3	3.6	V	

### 2.3.2 BACKLIGHT UNIT

Item	Symbol	Test Condition	Min.	Type	Max.	Unit	Note
Light Bar Voltage	V <sub>W</sub>	Ta = 25 °C	-	-	60	V <sub>RMS</sub>	
Converter Input Voltage	V <sub>BL</sub>	-	0	-	30	V	
Control Signal Level	-	-	-0.3	-	7	V	

Note (1) Permanent damage to the device may occur if maximum values are exceeded. Functional operation should be restricted to the conditions described under normal operating conditions.

Note (2) No moisture condensation or freezing.

Note (3) The control signals include On/Off Control and Internal PWM Control.

### 3. ELECTRICAL CHARACTERISTICS

#### 3.1 TFT LCD MODULE

Ta = 25 ± 2 °C

Parameter	Symbol	Value			Unit	Note	
		Min.	Typ.	Max.			
Power Supply Voltage	V <sub>CC</sub>	10.8	12	13.2	V	(1)	
Rush Current	I <sub>RUSH</sub>	-	-	4.17	A	(2)	
Power Supply Current	White Pattern	-	-	1.27	A	(3)	
	Horizontal Stripe	-	-	1.32	A		
	Black Pattern	-	-	0.58	A		
LVDS interface	Differential Input High Threshold Voltage	V <sub>LVTH</sub>	+100	-	-	mV	(4)
	Differential Input Low Threshold Voltage	V <sub>LVTL</sub>	-	-	-100	mV	
	Common Input Voltage	V <sub>CM</sub>	1.0	1.2	1.4	V	
	Differential input voltage	V <sub>ID</sub>	200	-	600	mV	
	Terminating Resistor	R <sub>T</sub>	-	100	-	ohm	
CMOS interface	Input High Threshold Voltage	V <sub>IH</sub>	2.7	-	3.3	V	
	Input Low Threshold Voltage	V <sub>IL</sub>	0	-	0.7	V	

Note (1) The module should be always operated within above ranges.

Note (2) Measurement Conditions:



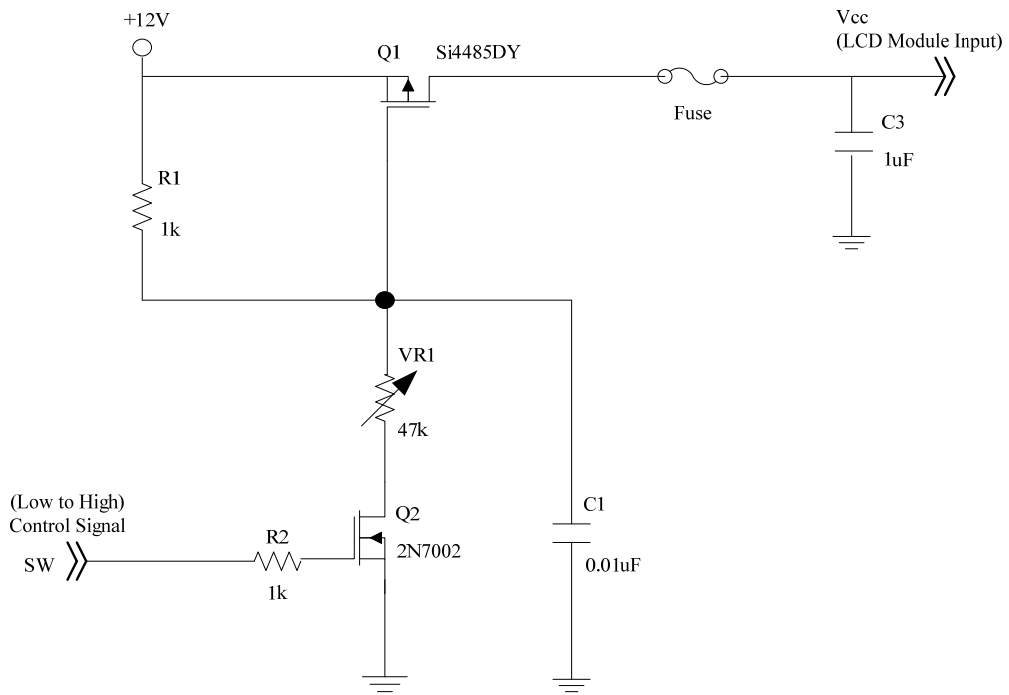

**Vcc rising time is 470us**

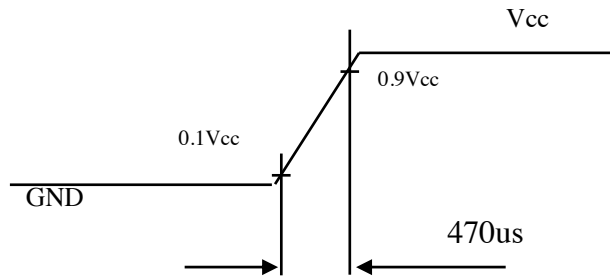

Note (3) The specified power supply current is under the conditions at  $V_{cc} = 12V$ ,  $T_a = 25 \pm 2 \text{ }^\circ\text{C}$ ,  $f_v = 120 \text{ Hz}$ , whereas a power dissipation check pattern below is displayed.

a. White Pattern



Active Area

b. Black Pattern



Active Area

c. Horizontal Pattern

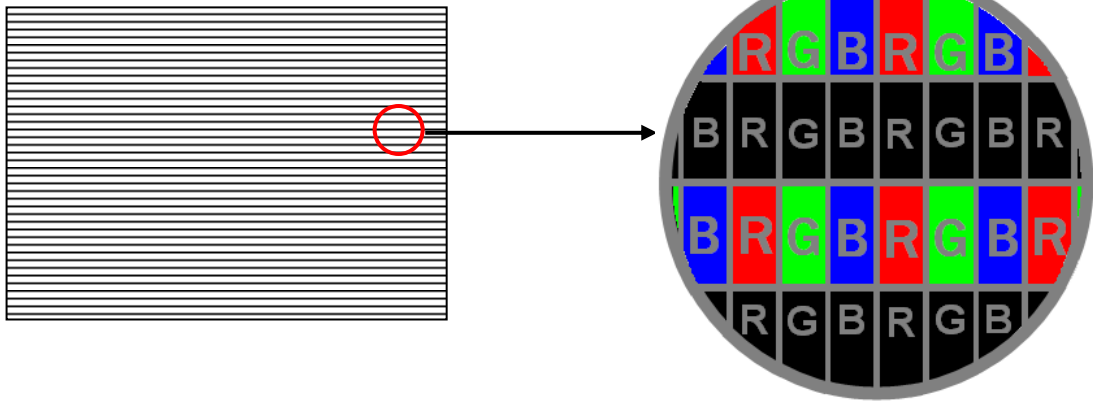

Note (4) The LVDS input characteristics are as follows:

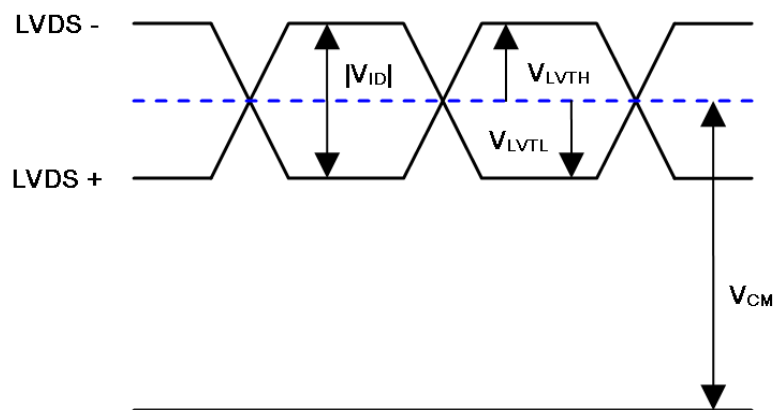

### 3.2 BACKLIGHT CONVERTER UNIT

#### 3.2.1 LED LIGHT BARCHARACTERISTICS (Ta = 25 ± 2 °C)

Parameter	Symbol	Value			Unit	Note
		Min.	Typ.	Max.		
Forward Voltage	V <sub>w</sub>	3.0		3.5	V <sub>RMS</sub>	I <sub>L</sub> =120.0mA
LED Current	I <sub>L</sub>	-	120		mA <sub>RMS</sub>	
Life time	-	30,000	-	-	Hrs	(1)

Note (1) The lifetime is defined as the time which luminance of the LED decays to 50% compared to the initial value, Operating condition: Continuous operating at Ta = 25±2°C, I<sub>L</sub> =120mA

#### 3.2.2 CONVERTER CHARACTERISTICS (Ta = 25 ± 2 °C)

Parameter	Symbol	Value			Unit	Note
		Min.	Typ.	Max.		
Power Consumption	P <sub>BL</sub>	-	95	100	W	(1),(2) I <sub>L</sub> = 120 mA
Converter Input Voltage	V <sub>BL</sub>	22.8	24.0	25.2	VDC	
Converter Input Current	I <sub>BL</sub>	-	3.96	4.17	A	Non Dimming
Rush current	I <sub>R</sub>	-	-	6.2	A	(3)
Dimming Frequency	FB	150	160	170	Hz	
Minimum Duty Ratio	DMIN	5	10	-	%	(4)

Note (1) The power supply capacity should be higher than the total converter power consumption P<sub>BL</sub>. Since the pulse width modulation (PWM) mode was applied for backlight dimming, the driving current changed as PWM duty on and off. The transient response of power supply should be considered for the changing loading when converter dimming.

Note (2) The measurement condition of Max. value is based on 42" backlight unit under input voltage 24V, average LED current 120 mA and lighting 1 hour later.

Note (3) The duration of rush current is about 30ms. Even though Inrush current is over the specified value, there is no problem if I<sup>2</sup>T of fuse Spec is satisfied.

Note (4) 5% minimum duty ratio is only valid for electrical operation.

### 3.2.3 CONVERTER INTERFACE CHARACTERISTICS

External dimming: 150Hz~170Hz, duty ratio: 10%~100%

Parameter		Symbol	Test Condition	Value			Unit	Note
				Min.	Typ.	Max.		
On/Off Control Voltage	ON	VBLON	—	2.0	—	5.0	V	
	OFF		—	0	—	0.8	V	
Internal PWM Control Voltage	MAX	VIPWM	—	3.15	—	3.45	V	maximum duty ratio
	MIN		—	—	0	—	V	minimum duty ratio
External PWM Control Voltage	HI	VEPWM	—	2.0	—	5.0	V	Duty on
	LO		—	0	—	0.8	V	Duty off
Status Signal	HI	Status	—	3.0	3.3	3.6	V	Normal
	LO		—	0	—	0.8	V	Abnormal
VBL Rising Time		Tr1	—	30	—	—	ms	10%-90%V <sub>BL</sub>
VBL Falling Time		Tf1	—	30	—	—	ms	
Control Signal Rising Time		Tr	—	—	—	100	ms	
Control Signal Falling Time		Tf	—	—	—	100	ms	
PWM Signal Rising Time		TPWMR	—	—	—	50	us	
PWM Signal Falling Time		TPWMF	—	—	—	50	us	
Input Impedance		Rin	—	1	—	—	MΩ	
PWM Delay Time		TPWM	—	100	—	—	ms	
BLON Delay Time	T <sub>on</sub>	—	—	300	—	—	ms	
	T <sub>on1</sub>	—	—	300	—	—	ms	
BLON Off Time		Toff	—	300	—	—	ms	

Note (1) The Dimming signal should be valid before backlight turns on by BLON signal. It is inhibited to change the internal/external PWM signal during backlight turn on period.

Note (2) The power sequence and control signal timing are shown in the following figure. For a certain reason, the converter has a possibility to be damaged with wrong power sequence and control signal timing.

Note (3) While system is turned ON or OFF, the power sequences must follow as below descriptions:

Turn ON sequence: VBL → PWM signal → BLON

Turn OFF sequence: BLOFF → PWM signal → VBL

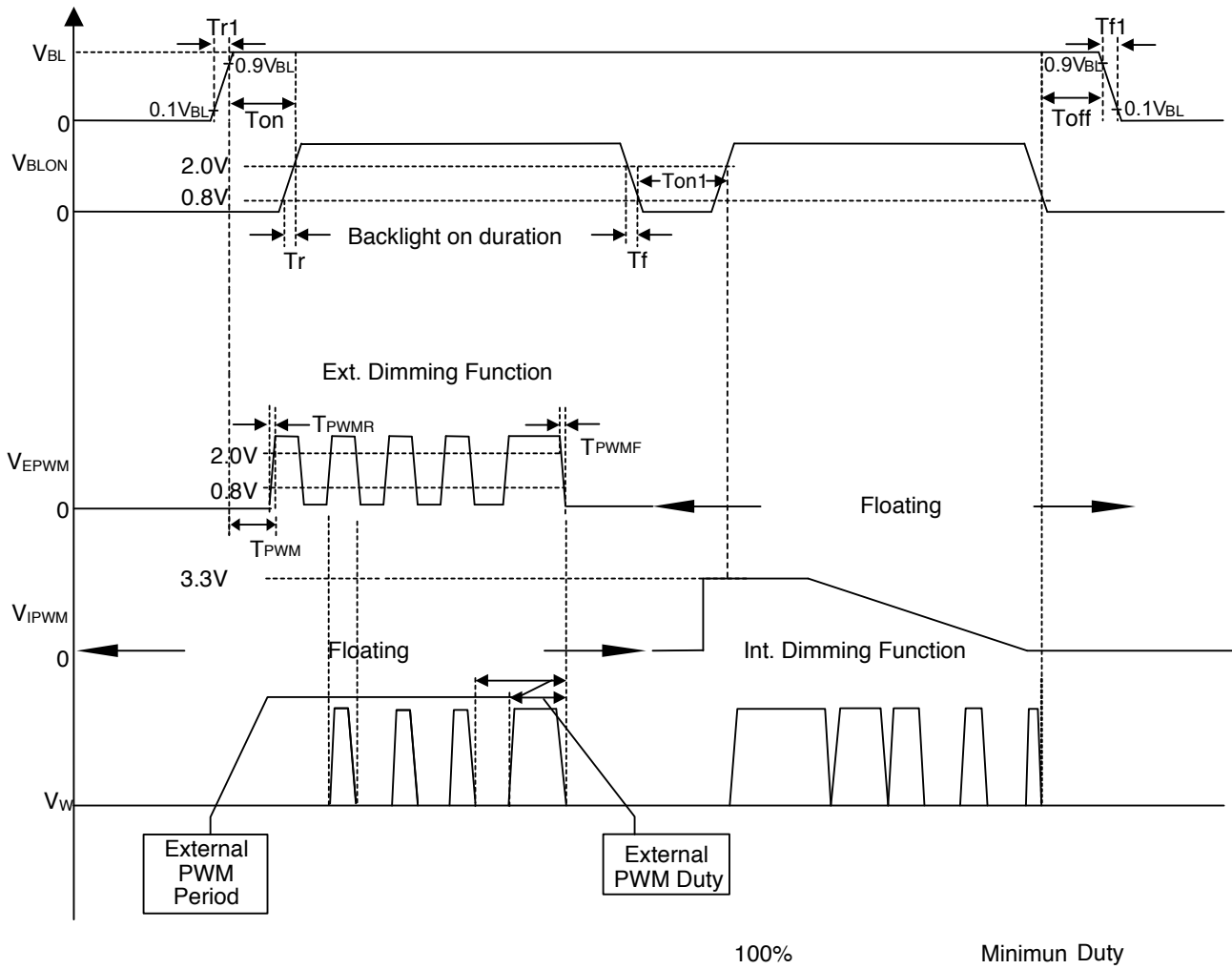

**4. BLOCK DIAGRAM OF INTERFACE**

**4.1 TFT LCD MODULE**

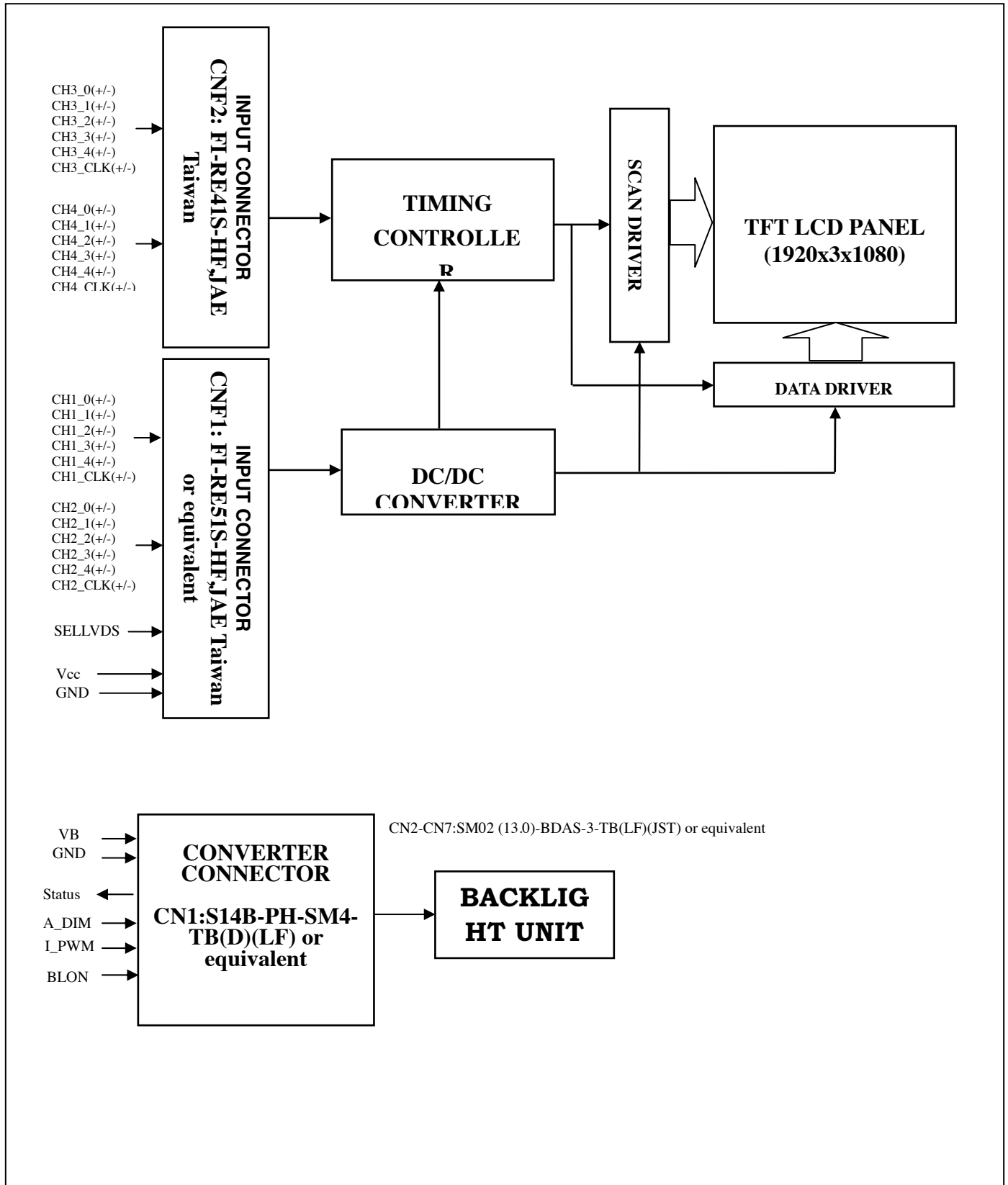

## 5. INTERFACE PIN CONNECTION

### 5.1 TFT LCD MODULE

CNF1 Connector Pin Assignment: (FI-RE51S-HF(JAE) or equivalent)

Pin	Name	Description	Note
1	GND	Ground	
2	N.C.	No Connection	(1)
3	N.C.	No Connection	(1)
4	N.C.	No Connection	(1)
5	N.C.	No Connection	(1)
6	N.C.	No Connection	(1)
7	SELLVDS	LVDS Data Format Selection	(2)
8	N.C.	No Connection	(1)
9	N.C.	No Connection	(1)
10	N.C.	No Connection	(1)
11	GND	Ground	
12	CH1[0]-	First pixel Negative LVDS differential data input. Pair 0	
13	CH1[0]+	First pixel Positive LVDS differential data input. Pair 0	
14	CH1[1]-	First pixel Negative LVDS differential data input. Pair 1	
15	CH1[1]+	First pixel Positive LVDS differential data input. Pair 1	
16	CH1[2]-	First pixel Negative LVDS differential data input. Pair 1 2	
17	CH1[2]+	First pixel Positive LVDS differential data input. Pair 2	
18	GND	Ground	
19	CH1CLK-	First pixel Negative LVDS differential clock input.	
20	CH1CLK+	First pixel Positive LVDS differential clock input.	
21	GND	Ground	
22	CH1[3]-	First pixel Negative LVDS differential data input. Pair 3	
23	CH1[3]+	First pixel Positive LVDS differential data input. Pair 3	
24	CH1[4]-	First pixel Negative LVDS differential data input. Pair 4	
25	CH1[4]+	First pixel Positive LVDS differential data input. Pair 4	
26	N.C.	No Connection	(1)
27	N.C.	No Connection	(1)
28	CH2[0]-	Second pixel Negative LVDS differential data input. Pair 0	

29	CH2[0]+	Second pixel Positive LVDS differential data input. Pair 0	
30	CH2[1]-	Second pixel Negative LVDS differential data input. Pair 1	
31	CH2[1]+	Second pixel Positive LVDS differential data input. Pair 1	
32	CH2[2]-	Second pixel Negative LVDS differential data input. Pair 2	
33	CH2[2]+	Second pixel Positive LVDS differential data input. Pair 2	
34	GND	Ground	
35	CH2CLK-	Second pixel Negative LVDS differential clock input.	
36	CH2CLK+	Second pixel Positive LVDS differential clock input.	
37	GND	Ground	
38	CH2[3]-	Second pixel Negative LVDS differential data input. Pair 3	
39	CH2[3]+	Second pixel Positive LVDS differential data input. Pair 3	
40	CH2[4]-	Second pixel Negative LVDS differential data input. Pair 4	
41	CH2[4]+	Second pixel Positive LVDS differential data input. Pair 4	
42	N.C.	No Connection	(1)
43	N.C.	No Connection	(1)
44	GND	Ground	
45	GND	Ground	
46	GND	Ground	
47	N.C.	No Connection	(1)
48	VCC	+12V power supply	
49	VCC	+12V power supply	
50	VCC	+12V power supply	
51	VCC	+12V power supply	

Note (1) LVDS connector pin order defined as follows

CNF2 Connector Pin Assignment (FI-RE41S-HF (JAE) or equivalent )

Pin	Name	Description	Note
1	GND	Ground	
2	N.C.	No Connection	(1)
3	N.C.	No Connection	(1)
4	N.C.	No Connection	(1)
5	N.C.	No Connection	(1)



6	N.C.	No Connection	(1)
7	N.C.	No Connection	(1)
8	N.C.	No Connection	(1)
9	GND	Ground	
10	CH3[0]-	Third pixel Negative LVDS differential data input. Pair 0	
11	CH3[0]+	Third pixel Positive LVDS differential data input. Pair 0	
12	CH3[1]-	Third pixel Negative LVDS differential data input. Pair 1	
13	CH3[1]+	Third pixel Positive LVDS differential data input. Pair 1	
14	CH3[2]-	Third pixel Negative LVDS differential data input. Pair 2	
15	CH3[2]+	Third pixel Positive LVDS differential data input. Pair 2	
16	GND	Ground	
17	CH3CLK-	Third pixel Negative LVDS differential clock input.	
18	CH3CLK+	Third pixel Positive LVDS differential clock input.	
19	GND	Ground	
20	CH3[3]-	Third pixel Negative LVDS differential data input. Pair 3	
21	CH3[3]+	Third pixel Positive LVDS differential data input. Pair 3	
22	CH3[4]-	Third pixel Negative LVDS differential data input. Pair 4	
23	CH3[4]+	Third pixel Positive LVDS differential data input. Pair 4	
24	N.C.	No Connection	(1)
25	N.C.	No Connection	(1)
26	CH4[0]-	Fourth pixel Negative LVDS differential data input. Pair 0	
27	CH4[0]+	Fourth pixel Positive LVDS differential data input. Pair 0	
28	CH4[1]-	Fourth pixel Negative LVDS differential data input. Pair 1	
29	CH4[1]+	Fourth pixel Positive LVDS differential data input. Pair 1	
30	CH4[2]-	Fourth pixel Negative LVDS differential data input. Pair 2	
31	CH4[2]+	Fourth pixel Positive LVDS differential data input. Pair 2	
32	GND	Ground	
33	CH4CLK-	Fourth pixel Negative LVDS differential clock input.	
34	CH4CLK+	Fourth pixel Positive LVDS differential clock input.	
35	GND	Ground	
36	CH4[3]-	Fourth pixel Negative LVDS differential data input. Pair 3	

37	CH4[3]+	Fourth pixel Positive LVDS differential data input. Pair 3	
38	CH4[4]-	Fourth pixel Negative LVDS differential data input. Pair 4	
39	CH4[4]+	Fourth pixel Positive LVDS differential data input. Pair 4	
40	N.C.	No Connection	(1)
41	N.C.	No Connection	(1)

Note (1) Reserved for internal use. Please leave it open.

Note (2) High=connect to +3.3V : JEIDA Format ; Low= connect to GND or Open : VESA Format.

Note (3)Interface optional pin has internal scheme as following diagram. Customer should keep the interface voltage level requirement as below.

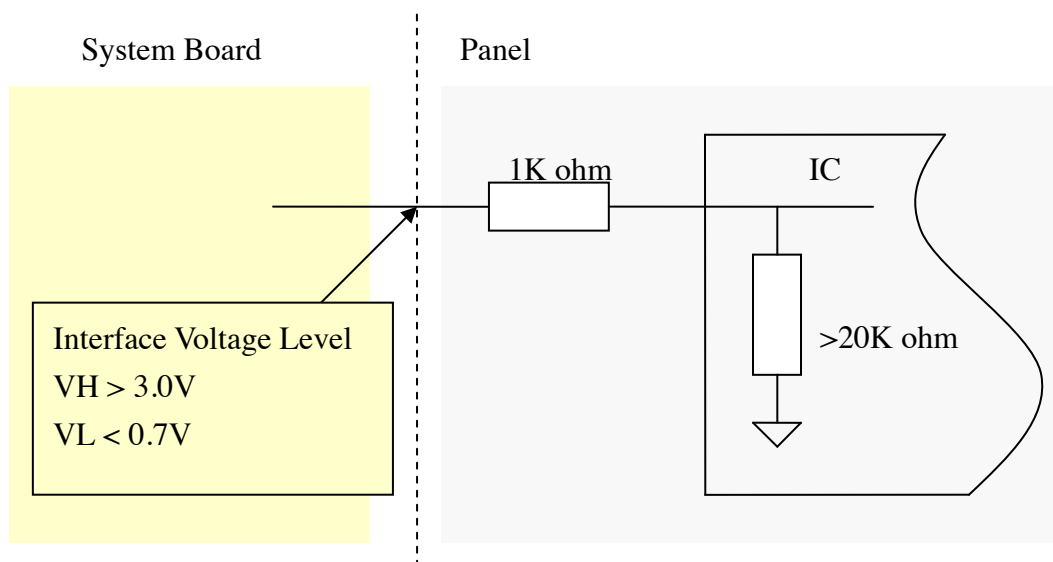

Note (4) LVDS 4-port Data Mapping

Port	Channel of LVDS	Data Stream
1st Port	First Pixel	1, 5, 9, .....1913, 1917
2nd Port	Second Pixel	2, 6, 10, ....1914, 1918
3rd Port	Third Pixel	3, 7, 11, ....1915, 1919
4th Port	Fourth Pixel	4, 8, 12, ....1916, 1920

## 5.2 BACKLIGHT UNIT

The pin configuration for the housing and leader wire is shown in the table below.

N2-CN7 (Housing): 51281-0994 (Molex) or equivalent

Pin No.	Symbol	Description
1	VLED	Positive of LED String
2	VLED	
3	NC	No Connection
4	NC	
5	NC	
6	VLED1-	Negative of LED String
7	VLED2-	
8	VLED3-	
9	VLED4-	
10	VLED5-	

Note (1) The backlight interface housing for high voltage side is a model 51281-0994, manufactured by Molex or equivalent. The mating header on converter part number is 51281-09

**5.3 CONVERTER UNIT**

CN1(Header): CI0114M1HR0-LF (CviiLux) or equivalent

Pin No.	Symbol	Description
1	VBL	+24V Power input
2		
3		
4		
5		
6	GND	Ground
7		
8		
9		
10		
11	STATUS	Normal (3.3V) Abnormal (0V)
12	E_PWM	External PWM control signal
13	I_PWM	Internal PWM control signal
14	BLON	Backlight on/off control

Notice:

#PIN 12:PWM Dimming Control (Use Pin 12) : Pin 13 must open.

#PIN 13:Analog Dimming Control (Use Pin 13) : 0V~3.3V and Pin 12 must open.

#Pin 13(I\_PWM) and Pin 12(E\_PWM) can not open in same period.

CN2 ~ CN5 : 51281-1094 (Molex) or E&T 7083K-F10N-00L

Pin No	Symbol	Feature
1	VLED5-	Negative of LED String
2	VLED4-	
3	VLED3-	
4	VLED2-	
5	VLED1-	
6	NC	No Connection
7	NC	
8	NC	
9	VLED+	Positive of LED String
10	VLED+	

5.4 BLOCK DIAGRAM OF INTERFACE

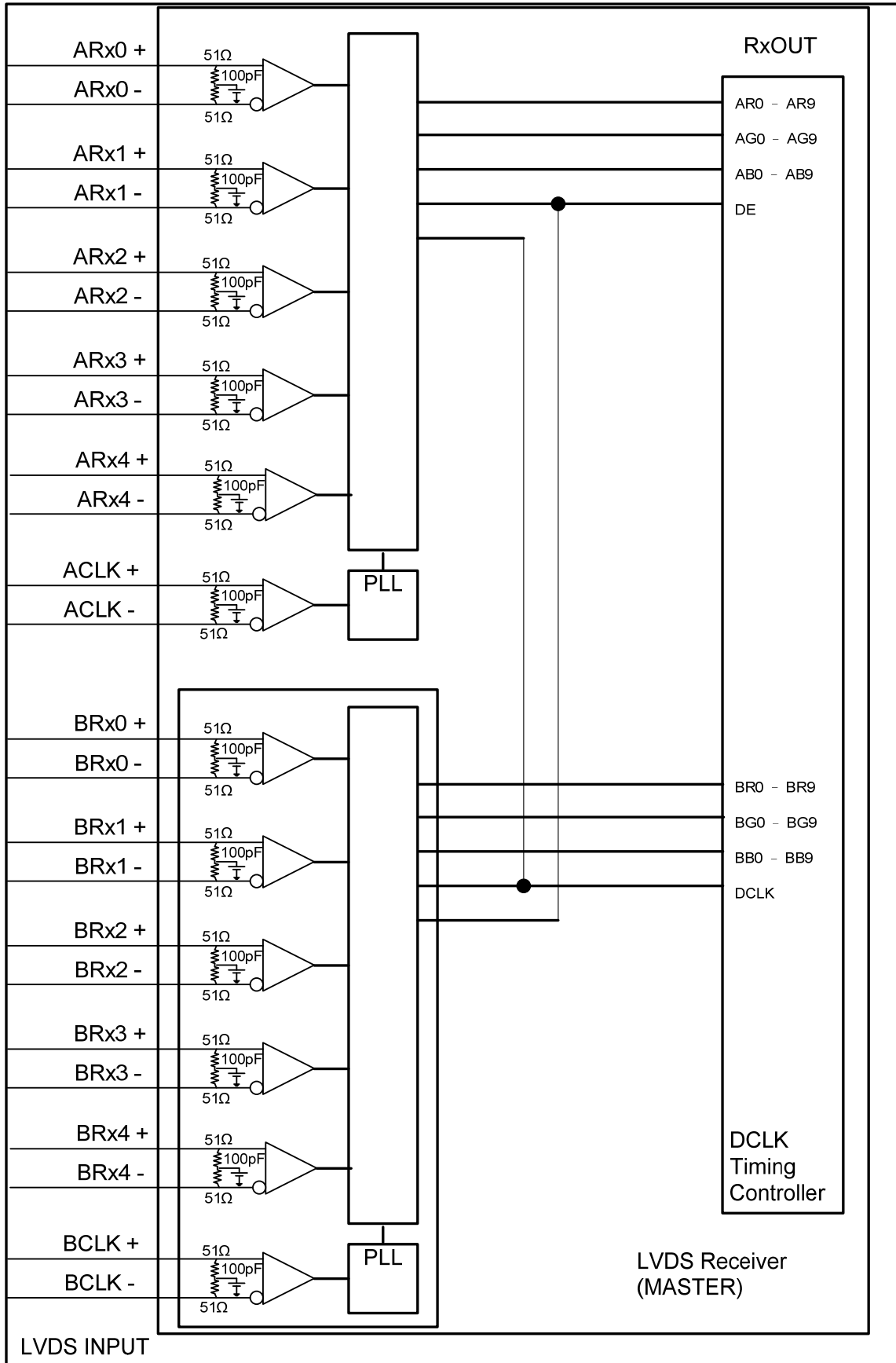

AR0~AR9: First pixel R data

AG0~AG9: First pixel G data

AB0~AB9: First pixel B data

BR0~BR9: Second pixel R data

BG0~BG9: Second pixel G data

BB0~BB9: Second pixel B data

DE: Data enable signal

DCLK: Data clock signal

The third and fourth pixel are followed the same rules.

CR0~CR9: Third pixel R data

CG0~CG9: Third pixel G data

CB0~CB9: Third pixel B data

DR0~DR9: Fourth pixel R data

DG0~DG9: Fourth pixel G data

DB0~DB9: Fourth pixel B data

Note (1) A ~ D channel are first, second, third and fourth pixel respectively.

Note (2) The system must have the transmitter to drive the module.

Note (3) LVDS cable impedance shall be 50 ohms per signal line or about 100 ohms per twist-pair line when it is used differentially.

5.5 LVDS INTERFACE

VESA Format : SELLVDS = L or Open

JEIDA Format : SELLVDS = H

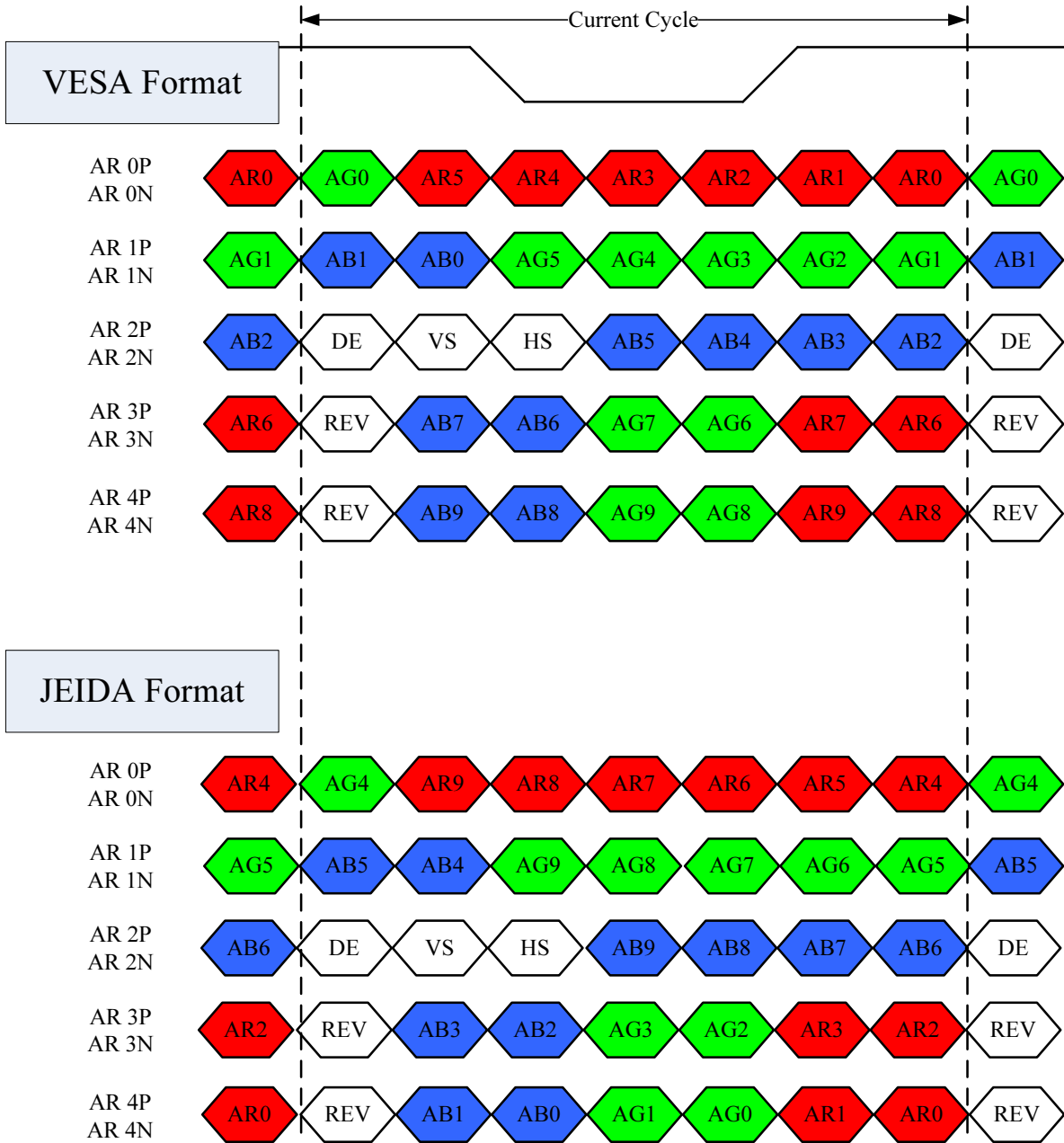

AR0~AR9: First Pixel R Data (9; MSB, 0; LSB)

AG0~AG9: First Pixel G Data (9; MSB, 0; LSB)

AB0~AB9: First Pixel B Data (9; MSB, 0; LSB)

DE : Data enable signal

DCLK : Data clock signal

RSV: Reserved

**5.6 COLOR DATA INPUT ASSIGNMENT**

The brightness of each primary color (red, green and blue) is based on the 10-bit gray scale data input for the color. The higher the binary input, the brighter the color. The table below provides the assignment of the color versus data input.

Color		Data Signal																											
		Red										Green										Blue							
		R9	R8	R7	R6	R5	R4	R3	R2	R1	R0	G9	G8	G7	G6	G5	G4	G3	G2	G1	G0	B9	B8	B7	B6	B5	B4	B3	B2
Basic Colors	Black	0	0	0	0	0	0	0	0	0	0	0	0	0	0	0	0	0	0	0	0	0	0	0	0	0	0	0	0
	Red	1	1	1	1	1	1	1	1	1	0	0	0	0	0	0	0	0	0	0	0	0	0	0	0	0	0	0	0
	Green	0	0	0	0	0	0	0	0	0	0	1	1	1	1	1	1	1	1	1	1	0	0	0	0	0	0	0	0
	Blue	0	0	0	0	0	0	0	0	0	0	0	0	0	0	0	0	0	0	0	0	1	1	1	1	1	1	1	1
	Cyan	0	0	0	0	0	0	0	0	0	0	1	1	1	1	1	1	1	1	1	1	1	1	1	1	1	1	1	1
	Magenta	1	1	1	1	1	1	1	1	1	0	0	0	0	0	0	0	0	0	0	0	1	1	1	1	1	1	1	1
	Yellow	1	1	1	1	1	1	1	1	1	1	1	1	1	1	1	1	1	1	1	1	0	0	0	0	0	0	0	0
	White	1	1	1	1	1	1	1	1	1	1	1	1	1	1	1	1	1	1	1	1	1	1	1	1	1	1	1	1
Gray Scale Of Red	Red (0) / Dark	0	0	0	0	0	0	0	0	0	0	0	0	0	0	0	0	0	0	0	0	0	0	0	0	0	0	0	
	Red (1)	0	0	0	0	0	0	0	0	1	0	0	0	0	0	0	0	0	0	0	0	0	0	0	0	0	0	0	
	Red (2)	0	0	0	0	0	0	0	0	1	0	0	0	0	0	0	0	0	0	0	0	0	0	0	0	0	0	0	
	:	:	:	:	:	:	:	:	:	:	:	:	:	:	:	:	:	:	:	:	:	:	:	:	:	:	:	:	
	:	:	:	:	:	:	:	:	:	:	:	:	:	:	:	:	:	:	:	:	:	:	:	:	:	:	:	:	
	Red (1021)	1	1	1	1	1	1	1	1	0	1	0	0	0	0	0	0	0	0	0	0	0	0	0	0	0	0	0	
	Red (1022)	1	1	1	1	1	1	1	1	1	0	0	0	0	0	0	0	0	0	0	0	0	0	0	0	0	0	0	
	Red (1023)	1	1	1	1	1	1	1	1	1	0	0	0	0	0	0	0	0	0	0	0	0	0	0	0	0	0	0	
Gray Scale Of Green	Green (0) / Dark	0	0	0	0	0	0	0	0	0	0	0	0	0	0	0	0	0	0	0	0	0	0	0	0	0	0	0	
	Green (1)	0	0	0	0	0	0	0	0	0	0	0	0	0	0	0	0	0	0	0	1	0	0	0	0	0	0	0	
	Green (2)	0	0	0	0	0	0	0	0	0	0	0	0	0	0	0	0	0	0	1	0	0	0	0	0	0	0	0	
	:	:	:	:	:	:	:	:	:	:	:	:	:	:	:	:	:	:	:	:	:	:	:	:	:	:	:	:	
	:	:	:	:	:	:	:	:	:	:	:	:	:	:	:	:	:	:	:	:	:	:	:	:	:	:	:	:	
	Green (1021)	0	0	0	0	0	0	0	0	0	0	1	1	1	1	1	1	1	1	0	1	0	0	0	0	0	0	0	
	Green (1022)	0	0	0	0	0	0	0	0	0	0	1	1	1	1	1	1	1	1	1	0	0	0	0	0	0	0	0	
	Green (1023)	0	0	0	0	0	0	0	0	0	0	1	1	1	1	1	1	1	1	1	0	0	0	0	0	0	0	0	
Gray Scale Of Blue	Blue (0) / Dark	0	0	0	0	0	0	0	0	0	0	0	0	0	0	0	0	0	0	0	0	0	0	0	0	0	0	0	
	Blue (1)	0	0	0	0	0	0	0	0	0	0	0	0	0	0	0	0	0	0	0	0	0	0	0	0	0	0	1	
	Blue (2)	0	0	0	0	0	0	0	0	0	0	0	0	0	0	0	0	0	0	0	0	0	0	0	0	0	1	0	
	:	:	:	:	:	:	:	:	:	:	:	:	:	:	:	:	:	:	:	:	:	:	:	:	:	:	:	:	
	:	:	:	:	:	:	:	:	:	:	:	:	:	:	:	:	:	:	:	:	:	:	:	:	:	:	:	:	
	Blue (1021)	0	0	0	0	0	0	0	0	0	0	0	0	0	0	0	0	0	0	0	1	1	1	1	1	1	1	0	



Blue (1022)	0	0	0	0	0	0	0	0	0	0	0	0	0	0	0	0	0	0	0	0	0	1	1	1	1	1	1	1	1	1	1	1	1	1	1	1	1	1	0	
Blue (1023)	0	0	0	0	0	0	0	0	0	0	0	0	0	0	0	0	0	0	0	0	0	0	1	1	1	1	1	1	1	1	1	1	1	1	1	1	1	1	1	1

Note (1) 0: Low Level Voltage, 1: High Level Voltage

## 6. INTERFACE TIMING

### 6.1 INPUT SIGNAL TIMING SPECIFICATIONS

(Ta = 25 ± 2 °C)

The input signal timing specifications are shown as the following table and timing diagram.

Signal	Item	Symbol	Min.	Typ.	Max.	Unit	Note
LVDS Receiver Clock	Frequency	$F_{clk_{in}}$ (=1/TC)	60	74.25	80	MHz	
	Input cycle to cycle jitter	$T_{rcj}$	-	-	200	ps	(3)
	Spread spectrum modulation range	$F_{clk_{in\_mod}}$	$F_{clk_{in}}-2\%$	-	$F_{clk_{in}}+2\%$	MHz	(4)
	Spread spectrum modulation frequency	$F_{SSM}$	-	-	200	KHz	
LVDS Receiver Data	Setup Time	$T_{lvsu}$	600	-	-	ps	(5)
	Hold Time	$T_{lvhd}$	600	-	-	ps	
Vertical Active Display Term	Frame Rate	$F_{r5}$	-	100	-	Hz	(6)
		$F_{r6}$	-	120	-	Hz	
	Total	$T_v$	1115	1125	1135	Th	$T_v=T_{vd}+T_{vb}$
	Display	$T_{vd}$	1080	1080	1080	Th	—
	Blank	$T_{vb}$	35	45	55	Th	—
Horizontal Active Display Term	Total	$T_h$	540	550	575	$T_c$	$T_h=T_{hd}+T_{hb}$
	Display	$T_{hd}$	480	480	480	$T_c$	—
	Blank	$T_{hb}$	60	70	95	$T_c$	—

Note (1) Since the module is operated in DE only mode, Hsync and Vsync input signals should be set to low logic level. Otherwise, this module would operate abnormally.

Note (2) Please make sure the range of pixel clock has follow the below equation:

$$F_{clk_{in}(max)} \geq F_{r6} \times T_v \times T_h$$

$$F_{r5} \times T_v \times T_h \geq F_{clk_{in}(min)}$$

**INPUT SIGNAL TIMING DIAGRAM**

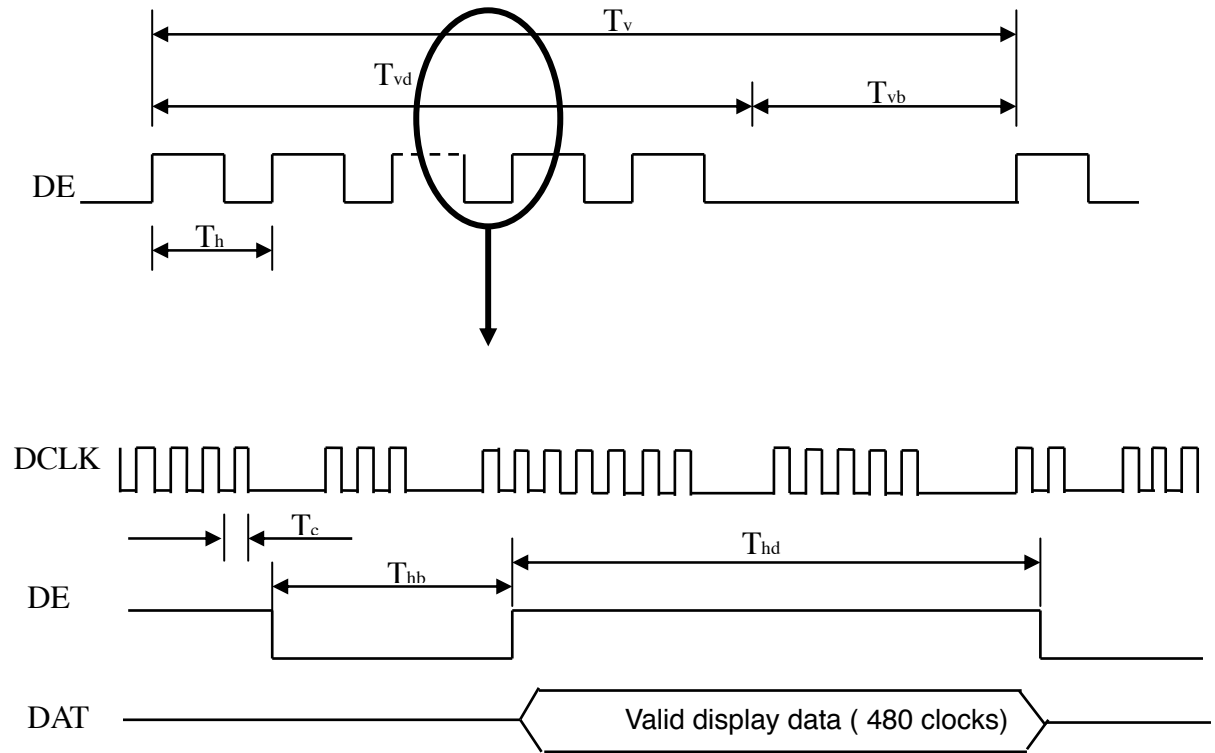

Note (3) The input clock cycle-to-cycle jitter is defined as below figures.  $Trcl = |T_1 - T_1|$

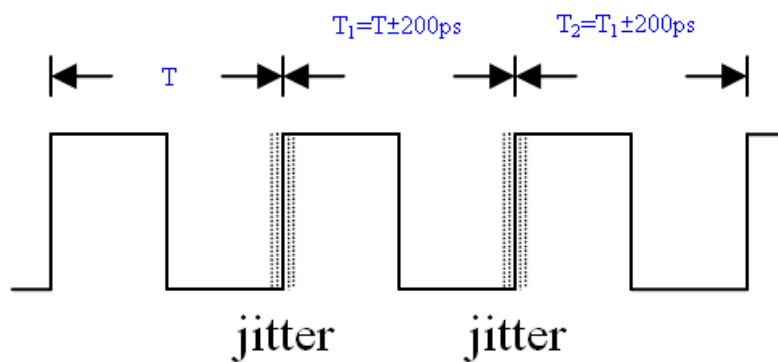

Note (4) The SSCG (Spread spectrum clock generator) is defined as below figures.

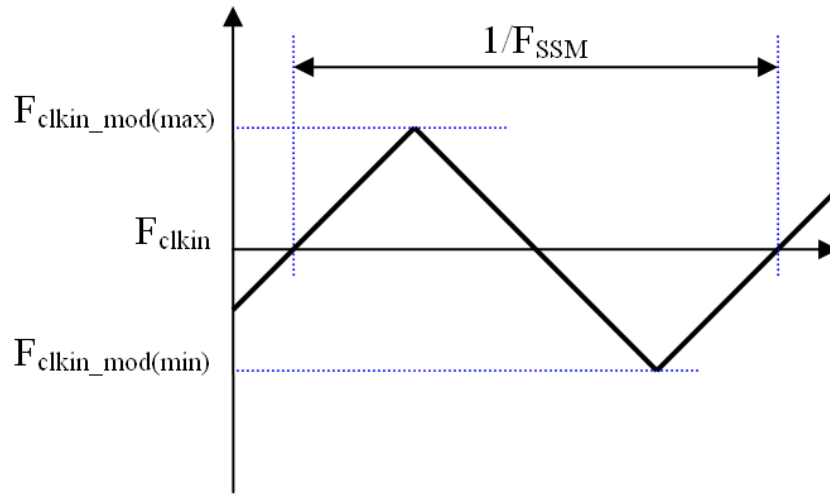

Note (5) The LVDS timing diagram and setup/hold time is defined and showing as the following figures.

**LVDS RECEIVER INTERFACE TIMING DIAGRAM**

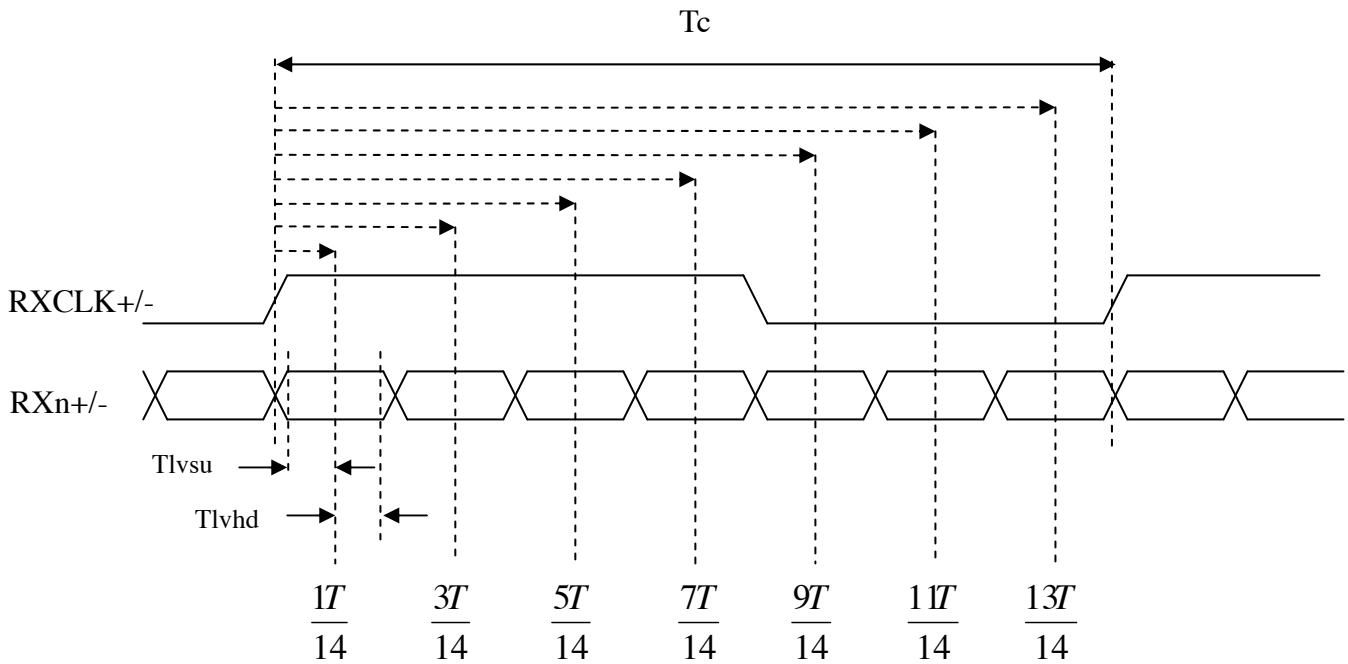

Note (6) (ODSEL) = H/L or open for 100/120Hz frame rate. Please refer to 5.1 for detail information

6.2 POWER ON/OFF SEQUENCE

(Ta = 25 ± 2 °C)

To prevent a latch-up or DC operation of LCD module, the power on/off sequence should be as the diagram below.

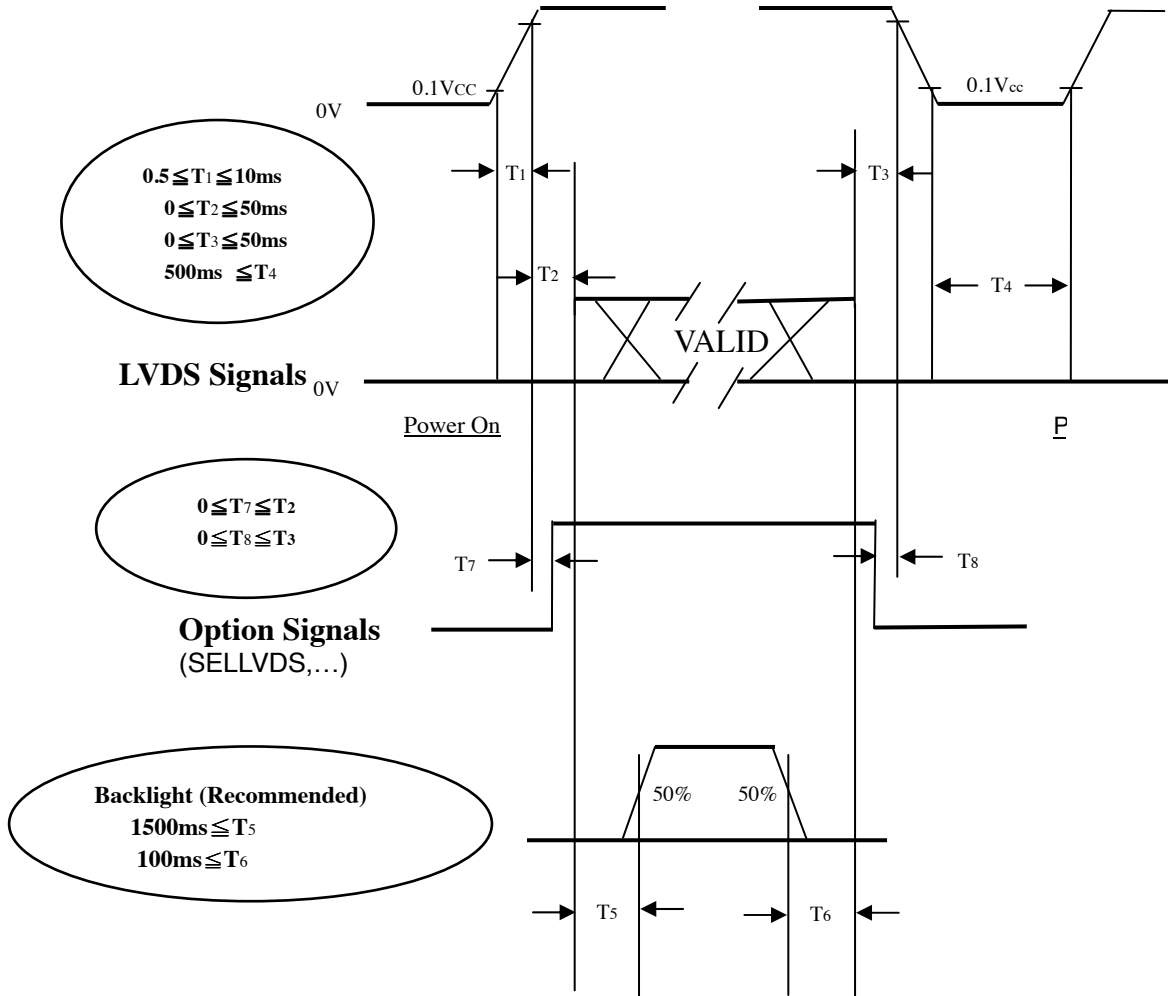

Power ON/OFF Sequence

Note (1) The supply voltage of the external system for the module input should follow the definition of Vcc.

Note (2) Apply the lamp voltage within the LCD operation range. When the backlight turns on before the LCD operation or the LCD turns off before the backlight turns off, the display may momentarily become abnormal screen.

Note (3) In case of Vcc is in off level, please keep the level of input signals on the low or high impedance. If T2 < 0, that maybe cause electrical overstress failure.

Note (4) T4 should be measured after the module has been fully discharged between power off and on period.

Note (5) Interface signal shall not be kept at high impedance when the power is on.

## 7. OPTICAL CHARACTERISTICS

### 7.1 TEST CONDITIONS

Item	Symbol	Value	Unit
Ambient Temperature	Ta	25±2	oC
Ambient Humidity	Ha	50±10	%RH
Supply Voltage	VCC	12	V
Input Signal	According to typical value in "3. ELECTRICAL CHARACTERISTICS"		
LED Current	IL	120	mA
Vertical Frame Rate	Fr	120	Hz

The LCD module should be stabilized at given temperature for 1 hour to avoid abrupt temperature change during measuring. In order to stabilize the luminance, the measurement should be executed after lighting backlight for 1 hour in a windless room.

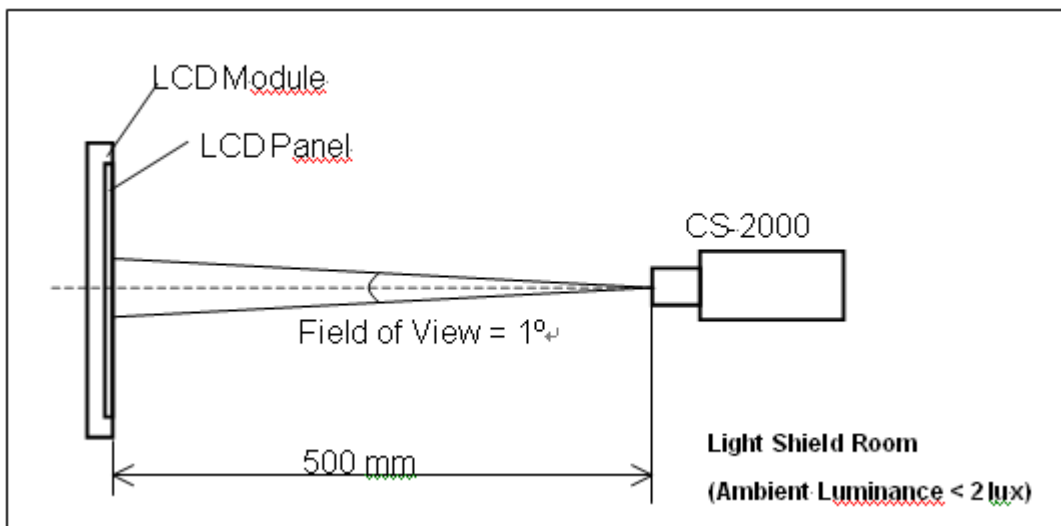

## 7.2 OPTICAL SPECIFICATIONS

The relative measurement methods of optical characteristics are shown in 7.2. The following items should be measured under the test conditions described in 7.1 and stable environment shown in 7.1.

Item		Symbol	Condition	Min.	Typ.	Max.	Unit	Note
Contrast Ratio		CR	$\theta_x=0^\circ, \theta_y=0^\circ$ Viewing angle at normal direction	4200	6000	-	-	Note (2)
Response Time		Gray to gray		-	5.5	10	ms	Note (3)
Center Luminance of White		LC		350	450	-	cd/m <sup>2</sup>	Note (4)
White Variation		$\delta W$		-	-	1.3	-	Note (6)
Cross Talk		CT		-	-	4	%	Note (5)
Color Chromaticity	Red	Rx		$\theta_x=0^\circ, \theta_y=0^\circ$ Viewing angle at normal direction	Typ. - 0.03	0.641	Typ+ 0.03	-
		Ry	0.324			-		
	Green	Gx	0.303			-		
		Gy	0.618			-		
	Blue	Bx	0.147			-		
		By	0.060			-		
	White	Wx	0.280			-		
		Wy	0.290			-		
	Color Gamut		C.G					72
Viewing Angle	Horizontal	$\theta_{x+}$	CR $\geq$ 20	80	88	-	Deg.	Note (1)
		$\theta_{x-}$		80	88	-		
	Vertical	$\theta_{Y+}$		80	88	-		
		$\theta_{Y-}$		80	88	-		

Note (1) Definition of Viewing Angle ( $\theta_x, \theta_y$ ):

Viewing angles are measured by Autronic Conoscope Cono-80.

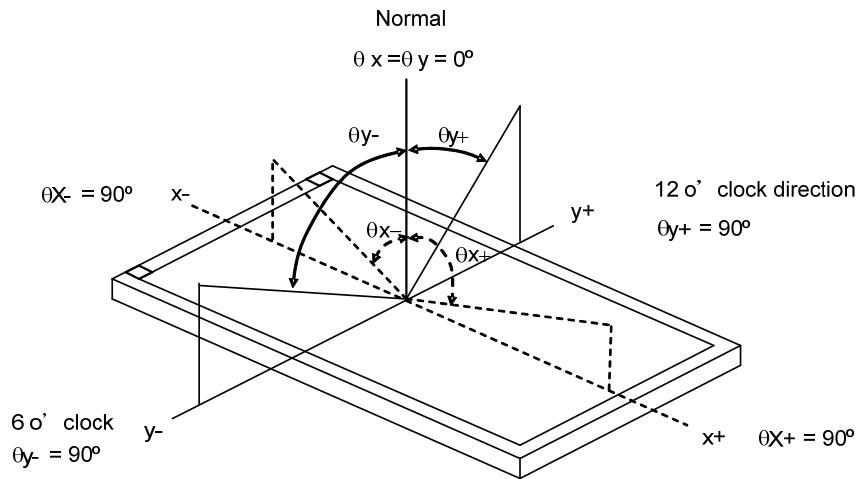

Note (2) Definition of Contrast Ratio (CR):

The contrast ratio can be calculated by the following expression.

$$\text{Contrast Ratio (CR)} = \frac{\text{Surface Luminance with all white pixels}}{\text{Surface Luminance with all black pixels}}$$

CR = CR (X), where CR (X) is corresponding to the Contrast Ratio of the point X at the figure in Note (6).

Note (3) Definition of Gray-to-Gray Switching Time:

**Optical Response**

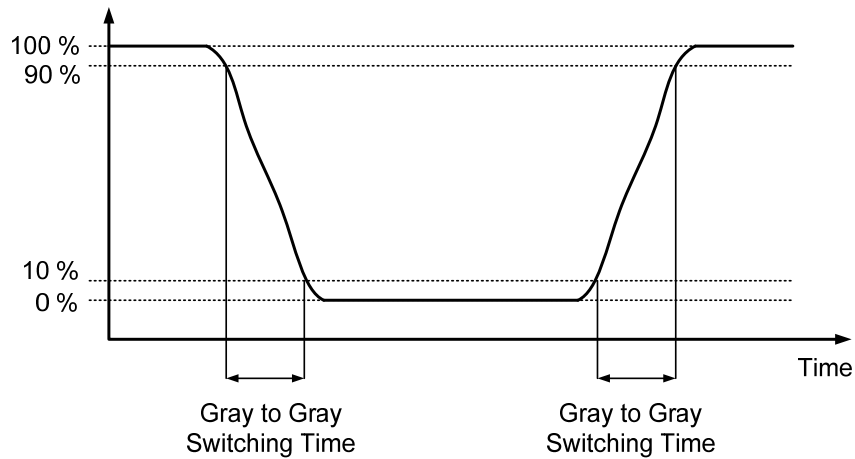

The driving signal means the signal of gray level 0, 252, 508, 764, and 1023.

Gray to gray average time means the average switching time of gray level 0, 252, 508, 764, and 1023. to each other.

Note (4) Definition of Luminance of White ( $L_C$ ):

Measure the luminance of gray level 1023. at center point and 5 points

$L_C = L (5)$ , where  $L (X)$  is corresponding to the luminance of the point X at the figure in Note (6).



Note (5) Definition of Cross Talk (CT):

$$CT = |Y_B - Y_A| / Y_A \times 100 (\%)$$

Where:

Y<sub>A</sub> = Luminance of measured location without gray level 0 pattern (cd/m<sup>2</sup>)

Y<sub>B</sub> = Luminance of measured location with gray level 0 pattern (cd/m<sup>2</sup>)

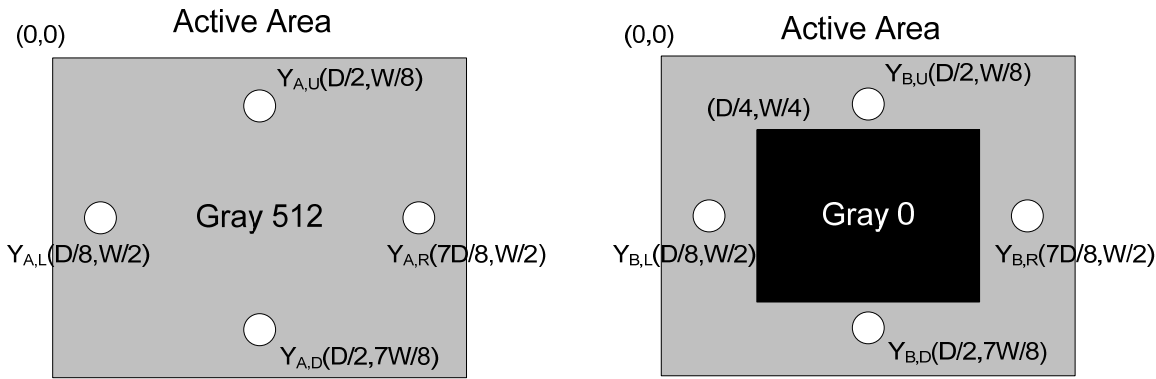

Note (6) Definition of White Variation ( $\delta W$ ):

Measure the luminance of gray level 1023 at 5 points

$$\delta W = \text{Maximum} [L(1), L(2), L(3), L(4), L(5)] / \text{Minimum} [L(1), L(2), L(3), L(4), L(5)]$$

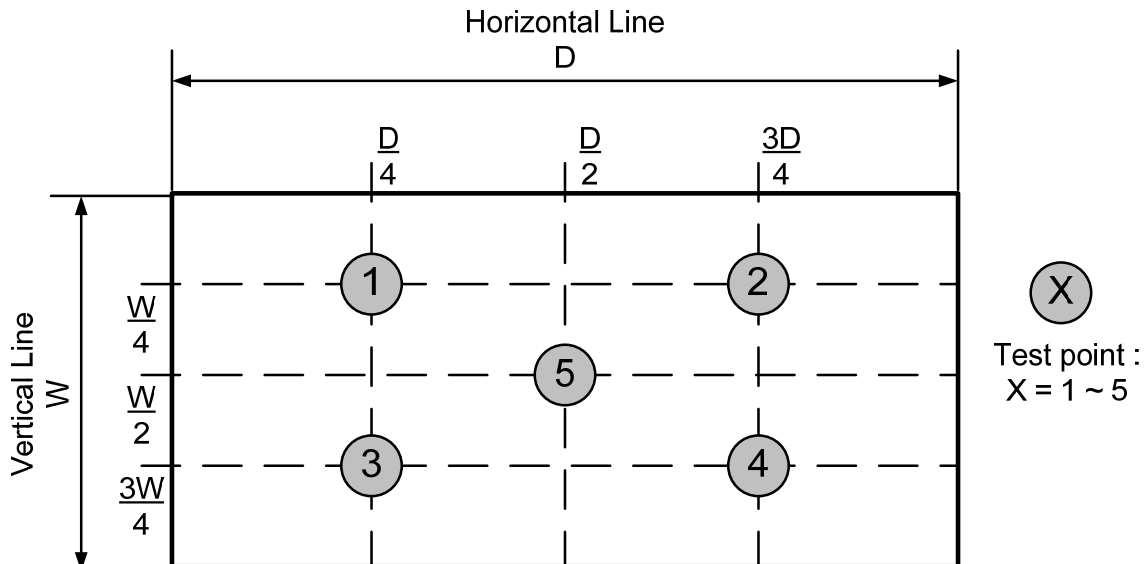

**8. DEFINITION OF LABELS**

**8.1 CMO MODULE LABEL**

The barcode nameplate is pasted on each module as illustration, and its definitions are as following explanation.

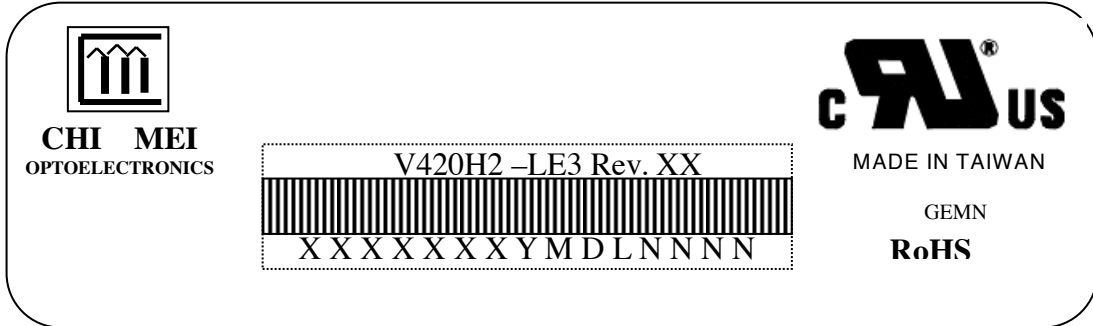

- (a) Model Name: V420H2-LE3
- (b) Revision: Rev. XX, for example: A0, A1... B1, B2... or C1, C2...etc.
- (c) Serial ID: XXXXXXXXYMDLNNNN

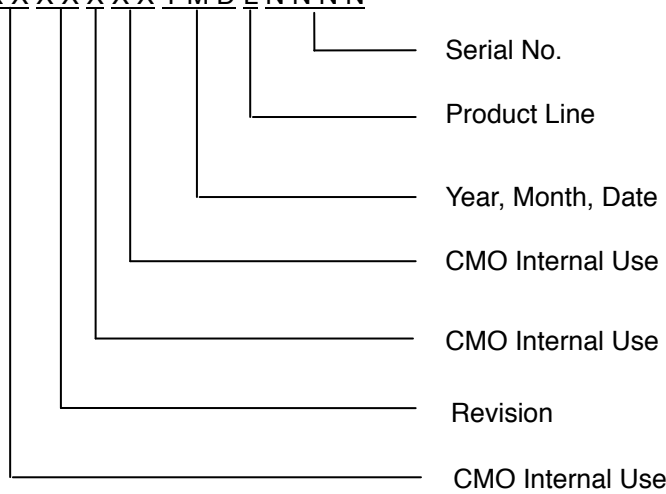

Serial ID includes the information as below:

- (a) Manufactured Date: Year: 2001=1, 2002=2, 2003=3, 2004=4...2010=0, 2011=1, 2012=2....  
 Month: 1~9, A~C, for Jan. ~ Dec.  
 Day: 1~9, A~Y, for 1<sup>st</sup> to 31<sup>st</sup>, exclude I ,O, and U.
- (b) Revision Code: Cover all the change
- (c) Serial No.: Manufacturing sequence of product
- (d) Product Line: 1 -> Line1, 2 -> Line 2, ...etc.

**9. PACKAGING**

**9.1 PACKING SPECIFICATIONS**

- (1) 5 LCD TV modules / 1 Box
- (2) Box dimensions : 1085(L)x296(W)x653(H)mm
- (3) Weight : Approx. 44 Kg(5 modules per carton)

**9.2 PACKING METHOD**

Figures 9-1 and 9-2 are the packing method

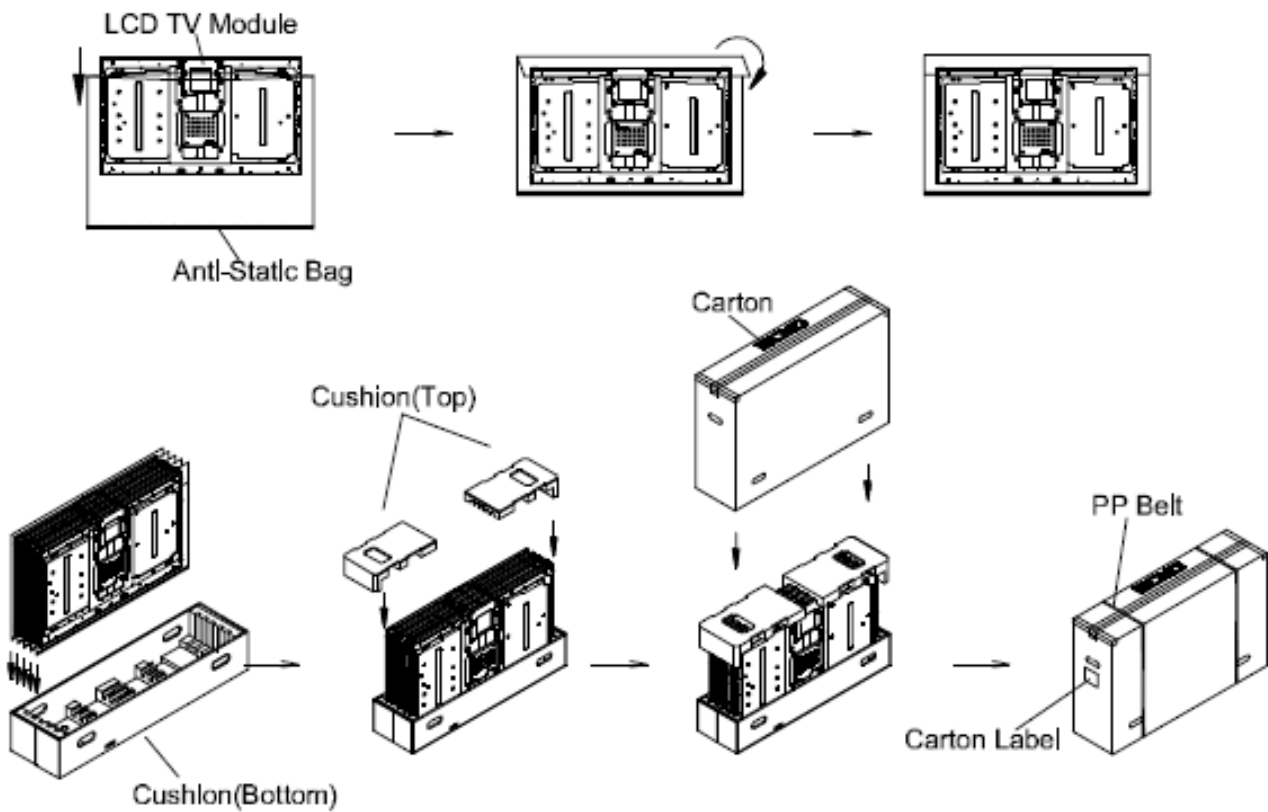

Figure.9-1 packing method

Sea / Land Transportation  
(40ft Container)

Air Transportation

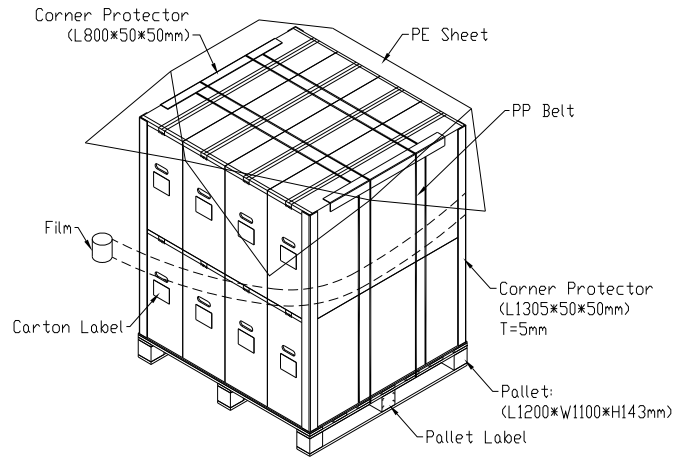
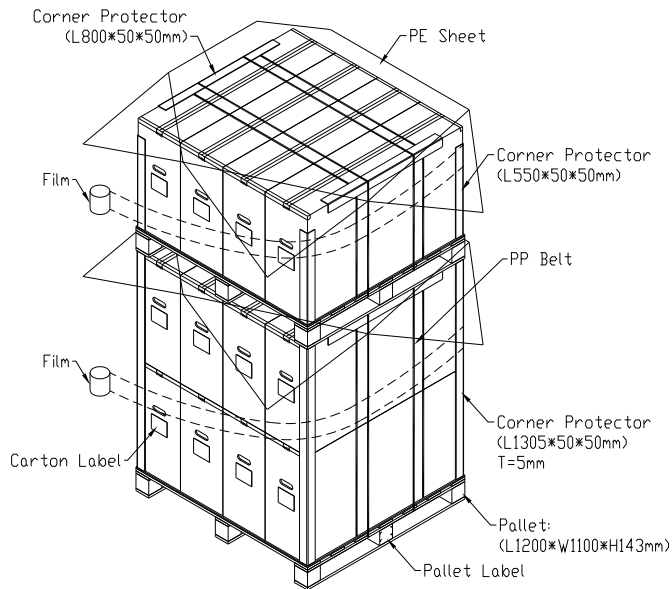

Figure.9-2 packing method

## 10. PRECAUTIONS

### 10.1 ASSEMBLY AND HANDLING PRECAUTIONS

- (1) Do not apply rough force such as bending or twisting to the module during assembly.
- (2) It is recommended to assemble or to install a module into the user's system in clean working areas. The dust and oil may cause electrical short or worsen the polarizer.
- (3) Do not apply pressure or impulse to the module to prevent the damage of LCD panel and backlight.
- (4) Always follow the correct power-on sequence when the LCD module is turned on. This can prevent the damage and latch-up of the CMOS LSI chips.
- (5) Do not plug in or pull out the I/F connector while the module is in operation.
- (6) Do not disassemble the module.
- (7) Use a soft dry cloth without chemicals for cleaning, because the surface of polarizer is very soft and easily scratched.
- (8) Moisture can easily penetrate into LCD module and may cause the damage during operation.
- (9) High temperature or humidity may deteriorate the performance of LCD module. Please store LCD modules in the specified storage conditions.
- (10) When ambient temperature is lower than 10°C, the display quality might be reduced. For example, the response time will become slow, and the starting voltage of LED light bar will be higher than that of room temperature.

### 10.2 SAFETY PRECAUTIONS

- (1) The startup voltage of a backlight is over 1000 Volts. It may cause an electrical shock while assembling with the converter. Do not disassemble the module or insert anything into the backlight unit.
- (2) If the liquid crystal material leaks from the panel, it should be kept away from the eyes or mouth. In case of contact with hands, skin or clothes, it has to be washed away thoroughly with soap.
- (3) After the module's end of life, it is not harmful in case of normal operation and storage.

11. MECHANICAL CHARACTERISTICS

