



Specification (tentative)

G12111-L01

30.7cm (12.1") - WXGA - MVA - LED

Version: 0.0

Date: June 2010

- CONTENTS -

REVISION HISTORY	-----	3
1. GENERAL DESCRIPTION	-----	4
1.1 OVERVIEW		
1.2 FEATURES		
1.3 APPLICATION		
1.4 GENERAL SPECIFICATIONS		
1.5 MECHANICAL SPECIFICATIONS		
2. ABSOLUTE MAXIMUM RATINGS	-----	5
2.1 ABSOLUTE RATINGS OF ENVIRONMENT		
2.2 ELECTRICAL ABSOLUTE RATINGS		
2.2.1 TFT LCD MODULE		
2.2.2 BACKLIGHT UNIT		
3. ELECTRICAL CHARACTERISTICS	-----	7
3.1 TFT LCD MODULE		
3.2 BACKLIGHT UNIT		
4. BLOCK DIAGRAM	-----	10
4.1 TFT LCD MODULE		
5. INPUT TERMINAL PIN ASSIGNMENT	-----	11
5.1 TFT LCD MODULE		
5.2 TIMING DIAGRAM OF LVDS INPUT SIGNAL		
5.3 COLOR DATA INPUT ASSIGNMENT		
5.4 EDID DATA STRUCTURE		
6. INTERFACE TIMING	-----	13
6.1 INPUT SIGNAL TIMING SPECIFICATIONS		
6.2 POWER ON/OFF SEQUENCE		
6.3 THE INPUT DATA FORMAT		
7. OPTICAL CHARACTERISTICS	-----	16
7.1 TEST CONDITIONS		
7.2 OPTICAL SPECIFICATIONS		
8. PRECAUTIONS	-----	19
8.1 HANDLING PRECAUTIONS		
8.2 STORAGE PRECAUTIONS		
8.3 OPERATION PRECAUTIONS		
9. PACKING	-----	20
9.1 PACKING SPECIFICATION		
9.2 PACKING METHOD		
10. DEFINITION OF LABELS	-----	21
10.1 CMI MODULE LABEL		
10.2 CARTON LABEL		
11. OUTLINE DIMENSION	-----	23

Version	Date	Page (New)	Section	Description
Ver 0.0	Jun. 02,'10	All	All	Tentative specification first issued.

1 GENERAL DESCRIPTION

1.1 OVERVIEW

G121I1-L01 is a 12.1" TFT Liquid Crystal Display module with LED Backlight unit and 30 pins LVDS interface. This module supports 1280 x 800 Wide-XGA MVA mode and can display 262,144 colors. The LED converter for Backlight is built in control board.

1.2 FEATURES

- MVA Type.
- WXGA (1280 x 800 pixels) resolution
- LED Backlight.
- Meet RoHS requirement
- 3.3V LVDS (Low Voltage Differential Signaling) interface

1.3 APPLICATION

- HMI

1.4 GENERAL SPECIFICATIONS

Item	Specification	Unit	Note
Active Area	261.12 (H) x 163.2 (V) (12.1" diagonal)	mm	(1)
Bezel Opening Area	265.10 (H) x 167.2 (V)	mm	
Driver Element	a-si TFT active matrix	-	-
Pixel Number	1280 x R.G.B. x 800	pixel	-
Pixel Pitch	0.204(H) x 0.204 (V)	mm	-
Pixel Arrangement	RGB vertical stripe	-	-
Display Colors	262,144	color	-
Transmissive Mode	Normally Black	-	-
Surface Treatment	Hard coating (3H), Anti-glare type	-	-

1.5 MECHANICAL SPECIFICATIONS

Item		Min.	Typ.	Max.	Unit	Note
Module Size	Horizontal(H)	277.5	278	278.5	mm	(1)
	Vertical(V)	183.5	184	184.5	mm	
	Depth(D)	7.5	8.0	8.5	mm	
Weight		TBD	TBD	TBD	g	

Note (1) Please refer to the attached drawings for more information of front and back outline dimensions.

2 ABSOLUTE MAXIMUM RATINGS

2.1 ABSOLUTE RATINGS OF ENVIRONMENT

Item	Symbol	Value		Unit	Note
		Min.	Max.		
Storage Temperature	T _{ST}	-20	+80	°C	(1)
Operating Ambient Temperature	T _{OP}	-10	+70	°C	(1), (2)
Shock (Non-Operating)	S _{NOP}	-	25/6	G/ms	(3), (5)
Vibration (Non-Operating)	V _{NOP}	-	1.0	G	(4), (5)

Note (1) (a) 90 %RH Max. (Ta ≤ 40 °C).

(b) Wet-bulb temperature should be 39 °C Max. (Ta > 40 °C).

(c) No condensation.

Note (2) The temperature of panel display surface area should be 0 °C Min. and 60 °C Max.

Relative Humidity (%RH)

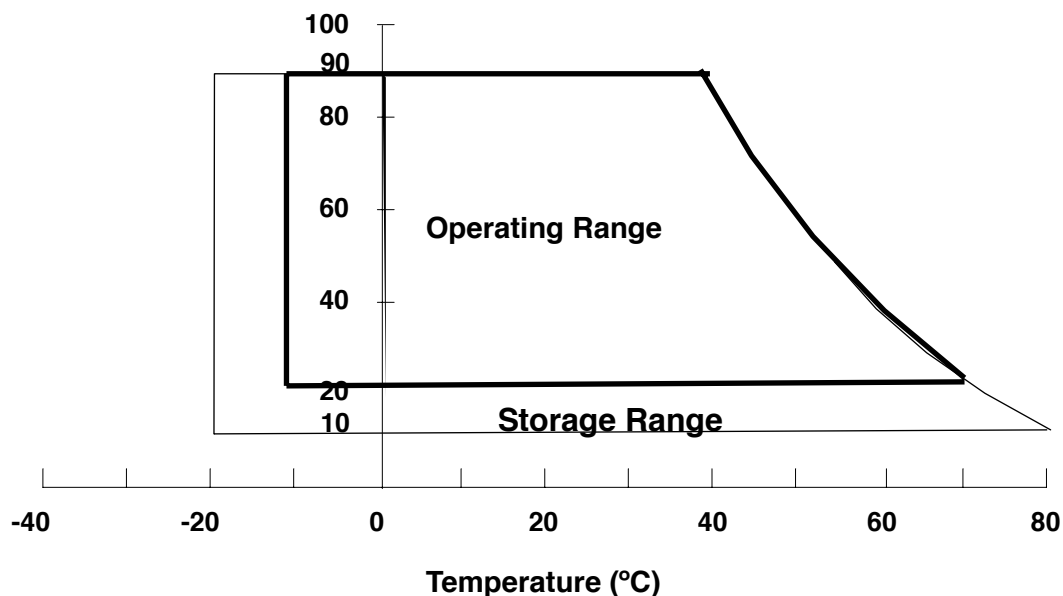

Note (3) 1 time for ± X, ± Y, ± Z. for Condition (25G / 6ms) is half Sine Wave,.

Note (4) 5- 9Hz: 3,5mm amplitude 9- 500Hz: 1g- each 10 cycles / axis (X,Y,Z); 1 octave / min.

Note (5) At testing Vibration and Shock, the fixture in holding the module has to be hard and rigid enough so that the module would not be twisted or bent by the fixture.

The fixing condition is shown as below:

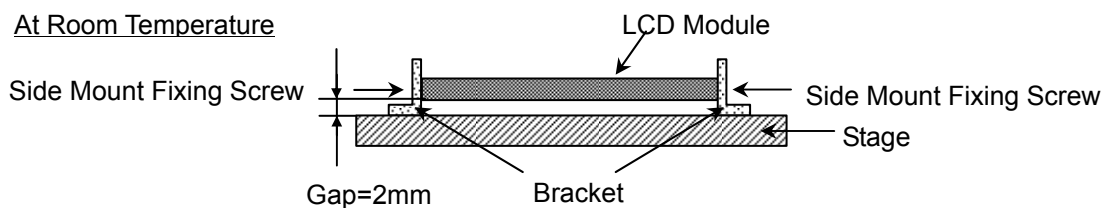

2.2 ELECTRICAL ABSOLUTE RATINGS

2.2.1 TFT LCD MODULE

Item	Symbol	Value		Unit	Note
		Min.	Max.		
Power Supply Voltage	V _{CC}	-0.3	+4.0	V	(1)
Logic Input Voltage	V _{IN}	-0.3	V _{CC} +0.3	V	

2.2.2 BACKLIGHT UNIT

Item	Value			Unit	Note
	Min	Typ.	Max.		
LED Converter Input voltage	10.8	12	13.2	V _{DC}	(1), (2)
LED Converter Input Current	-	TBD	-	mA _{DC}	

Note (1) Permanent damage to the device may occur if maximum values are exceeded. Function operation should be restricted to the conditions described under Normal Operating Conditions.

Note (2) Specified values are for LED (Refer to Section 3.2 for further information).

3 ELECTRICAL CHARACTERISTICS

3.1 TFT LCD MODULE

Parameter	Symbol	Value			Unit	Note
		Min.	Typ.	Max.		
Power Supply Voltage	V _{CC}	3.0	3.3	3.6	V	-
Permissible Ripple Voltage	V _{RP}	-	50	-	mV	-
Rush Current	I _{RUSH}	-	-	1.5	A	(2)
Initial Stage Current	I _{IS}	-	-	1.0	A	(2)
Power Supply Current	White	-	450	-	mA	(3)a
	Black	-	350	-	mA	(3)b
LVDS Differential Input High Threshold	V _{TH(LVDS)}	-	-	+100	mV	(5), V _{CM} =1.2V
LVDS Differential Input Low Threshold	V _{TL(LVDS)}	-100	-	-	mV	(5) V _{CM} =1.2V
LVDS Common Mode Voltage	V _{CM}	1.125	-	1.375	V	(5)
LVDS Differential Input Voltage	V _{ID}	100	-	600	mV	(5)
Terminating Resistor	R _T	-	100	-	Ohm	
Power per EBL WG	P _{EBL}	-	2.68	-	W	(4)

Note (1) The assembly should be always operated within above ranges.

Note (2) Measurement Conditions:

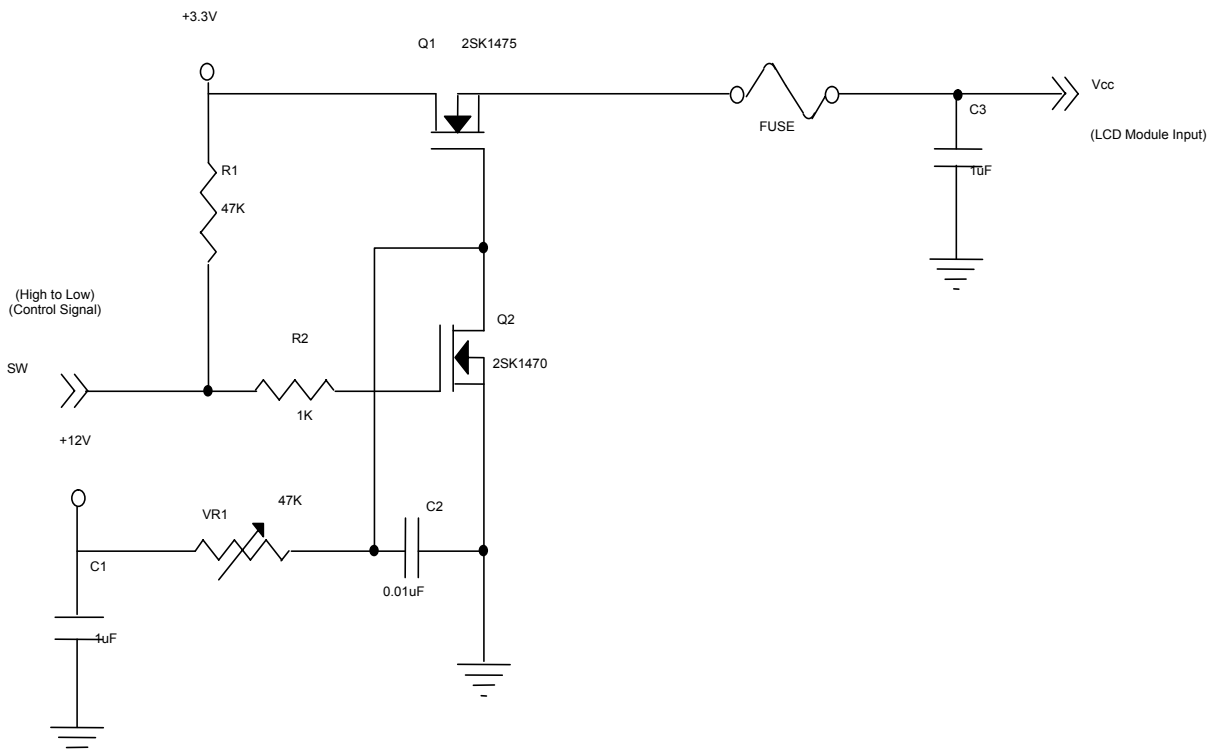

VCC rising time is 470us

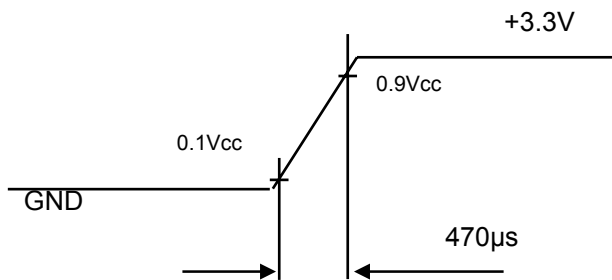

Note (3) The specified power supply current is under the conditions at V_{cc} = 3.3 V, T_a = 25 ± 2 °C, f_v = 60 Hz, whereas a power dissipation check pattern below is displayed.

a. White Pattern

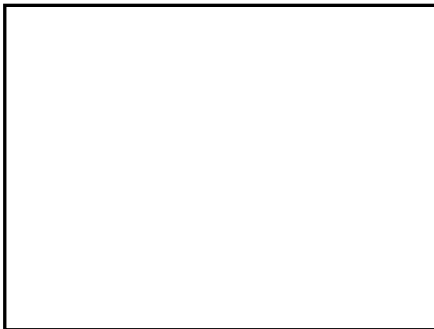

Active Area

b. Black Pattern

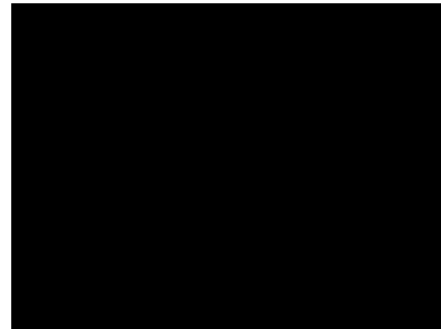

Active Area

c. Vertical Stripe Pattern

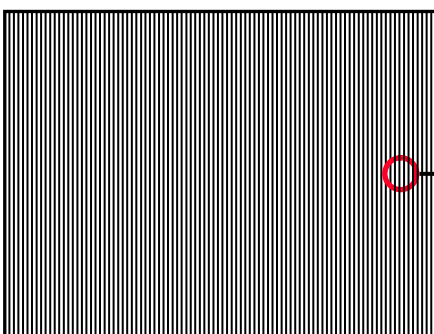

Active Area

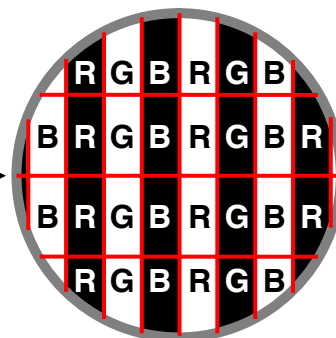

3.2 BACKLIGHT UNIT

$T_a = 25 \pm 2 \text{ }^\circ\text{C}$

Parameter	Symbol	Value			Unit	Note
		Min.	Typ.	Max.		
(LED Converter input voltage)	V_L	10.8	12	13.2	V_{DC}	(Duty 100%)
(LED light bar input current)	I_L	-	TBD	-	mA_{DC}	(Duty 100%)
LED Lightbar Voltage	V_f	-	35.2	-	V_{DC}	$I_f = 80 \text{ mA/EA}$
LED Current	I_f	-	80	-	mA	Per EA
Power Consumption	P_f	-	TBD	-	W	$I_f = 80 \text{ mA/EA}$
LED Life Time	L_{BL}	50000	-	-	Hrs	(1)

Note (1) LED current is measured by utilizing a high frequency current meter as shown below:

Note (2) The lifetime of LED is defined as the time when it continues to operate under the conditions at $T_a = 25 \pm 2 \text{ }^\circ\text{C}$ and $I_{LED} = 80\text{mA}_{DC}$ (LED forward current) until the brightness becomes $\leq 50\%$ of its original value.

Note (3) $P_L = I_o \times V_o$

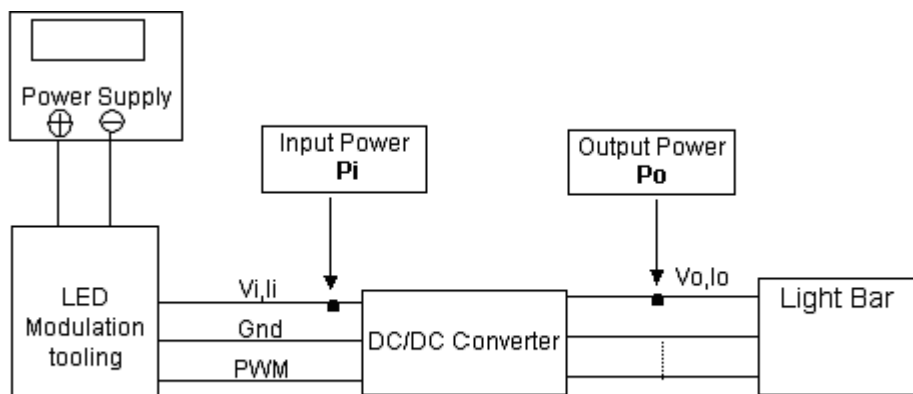

4 BLOCK DIAGRAM

4.1 TFT LCD MODULE

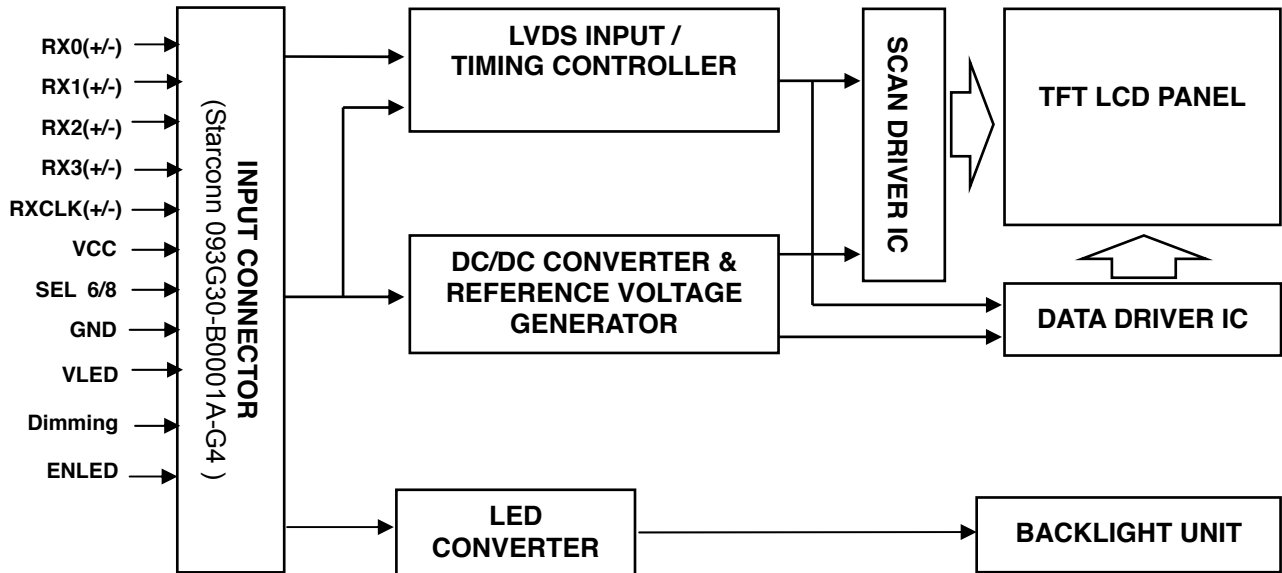

5 INPUT TERMINAL PIN ASSIGNMENT

5.1 TFT LCD MODULE

Pin No.	Symbol	Description	Note
1	12V	LED power	-
2	12V	LED power	-
3	12V	LED power	-
4	12V	LED power	-
5	ENLED	Enable pin	-
6	Dimming	Backlight Adjust	-
7	GND	Ground	-
8	GND	Ground	-
9	VCC	Power supply: +3.3V	-
10	VCC	Power supply: +3.3V	-
11	GND	Ground	-
12	GND	Ground	-
13	RX0-	Negative transmission data of pixel 0	-
14	RX0+	Positive transmission data of pixel 0	-
15	GND	Ground	-
16	RX1-	Negative transmission data of pixel 1	-
17	RX1+	Positive transmission data of pixel 1	-
18	GND	Ground	-
19	RX2-	Negative transmission data of pixel 2	-
20	RX2+	Positive transmission data of pixel 2	-
21	GND	Ground	-
22	RXCLK-	Negative of clock	-
23	RXCLK+	Positive of clock	-
24	GND	Ground	-
25	RX3-	Negative transmission data of pixel 3	-
26	RX3+	Positive transmission data of pixel 3	-
27	GND	Ground	-
28	SEL6/8	LVDS 6/8 bit select function control,	-2
		Low or NC → 8 bit Input Mode	
		High → 6bit Input Mode	
29	GND	Ground	-
30	GND	Ground	-

Note (1) Connector Part No.: Starconn 093G30-B0001A-G4

Note (2) "Low" stands for 0V. "High" stands for 3.3V

5.2 COLOR DATA INPUT ASSIGNMENT

The brightness of each primary color (red, green and blue) is based on the 6-bit gray scale data input for the color. The higher the binary input, the brighter the color. The table below provides the assignment of color versus data input.

Color		Data Signal																	
		Red						Green						Blue					
		R5	R4	R3	R2	R1	R0	G5	G4	G3	G2	G1	G0	B5	B4	B3	B2	B1	B0
Basic Colors	Black	0	0	0	0	0	0	0	0	0	0	0	0	0	0	0	0	0	0
	Red	1	1	1	1	1	1	0	0	0	0	0	0	0	0	0	0	0	0
	Green	0	0	0	0	0	0	1	1	1	1	1	1	0	0	0	0	0	0
	Blue	0	0	0	0	0	0	0	0	0	0	0	0	1	1	1	1	1	1
	Cyan	0	0	0	0	0	0	1	1	1	1	1	1	1	1	1	1	1	1
	Magenta	1	1	1	1	1	1	0	0	0	0	0	0	1	1	1	1	1	1
	Yellow	1	1	1	1	1	1	1	1	1	1	1	1	0	0	0	0	0	0
	White	1	1	1	1	1	1	1	1	1	1	1	1	1	1	1	1	1	1
Gray Scale Of Red	Red(0)/Dark	0	0	0	0	0	0	0	0	0	0	0	0	0	0	0	0	0	0
	Red(1)	0	0	0	0	0	1	0	0	0	0	0	0	0	0	0	0	0	0
	Red(2)	0	0	0	0	1	0	0	0	0	0	0	0	0	0	0	0	0	0
	:	:	:	:	:	:	:	:	:	:	:	:	:	:	:	:	:	:	:
	:	:	:	:	:	:	:	:	:	:	:	:	:	:	:	:	:	:	:
	:	:	:	:	:	:	:	:	:	:	:	:	:	:	:	:	:	:	:
	Red(61)	1	1	1	1	0	1	0	0	0	0	0	0	0	0	0	0	0	0
	Red(62)	1	1	1	1	1	0	0	0	0	0	0	0	0	0	0	0	0	0
Red(63)	1	1	1	1	1	1	0	0	0	0	0	0	0	0	0	0	0	0	
Gray Scale Of Green	Green(0)/Dark	0	0	0	0	0	0	0	0	0	0	0	0	0	0	0	0	0	0
	Green(1)	0	0	0	0	0	0	0	0	0	0	1	0	0	0	0	0	0	0
	Green(2)	0	0	0	0	0	0	0	0	0	0	1	0	0	0	0	0	0	0
	:	:	:	:	:	:	:	:	:	:	:	:	:	:	:	:	:	:	:
	:	:	:	:	:	:	:	:	:	:	:	:	:	:	:	:	:	:	:
	:	:	:	:	:	:	:	:	:	:	:	:	:	:	:	:	:	:	:
	Green(61)	0	0	0	0	0	0	1	1	1	1	0	1	0	0	0	0	0	0
	Green(62)	0	0	0	0	0	0	1	1	1	1	1	0	0	0	0	0	0	0
Green(63)	0	0	0	0	0	0	1	1	1	1	1	1	0	0	0	0	0	0	
Gray Scale Of Blue	Blue(0)/Dark	0	0	0	0	0	0	0	0	0	0	0	0	0	0	0	0	0	0
	Blue(1)	0	0	0	0	0	0	0	0	0	0	0	0	0	0	0	0	0	1
	Blue(2)	0	0	0	0	0	0	0	0	0	0	0	0	0	0	0	0	1	0
	:	:	:	:	:	:	:	:	:	:	:	:	:	:	:	:	:	:	:
	:	:	:	:	:	:	:	:	:	:	:	:	:	:	:	:	:	:	:
	:	:	:	:	:	:	:	:	:	:	:	:	:	:	:	:	:	:	:
	Blue(61)	0	0	0	0	0	0	0	0	0	0	0	0	1	1	1	1	0	1
	Blue(62)	0	0	0	0	0	0	0	0	0	0	0	0	1	1	1	1	1	0
Blue(63)	0	0	0	0	0	0	0	0	0	0	0	0	1	1	1	1	1	1	

Note (1) 0: Low Level Voltage, 1: High Level Voltage

6. INTERFACE TIMING

6.1 INPUT SIGNAL TIMING SPECIFICATIONS

The input signal timing specifications are shown as the following table and timing diagram.

Signal	Item	Symbol	Min.	Typ.	Max.	Unit	Note
DCLK	Frequency	1/Tc	67.45	71	74.55	MHz	-
DE	Vertical Total Time	TV	810	823	1000	TH	-
	Vertical Addressing Time	TVD	800	800	800	TH	-
	Horizontal Total Time	TH	1360	1440	1600	Tc	-
	Horizontal Addressing Time	THD	1280	1280	1280	Tc	-

INPUT SIGNAL TIMING DIAGRAM

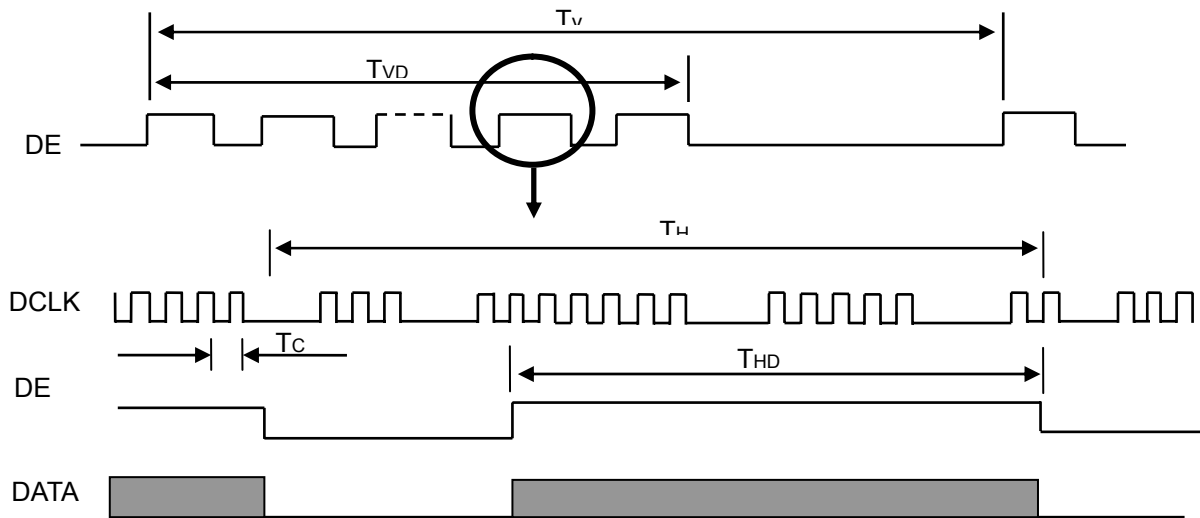

6.2 POWER ON/OFF SEQUENCE

To prevent a latch-up or DC operation of LCD assembly, the power on/off sequence should be as the diagram below.

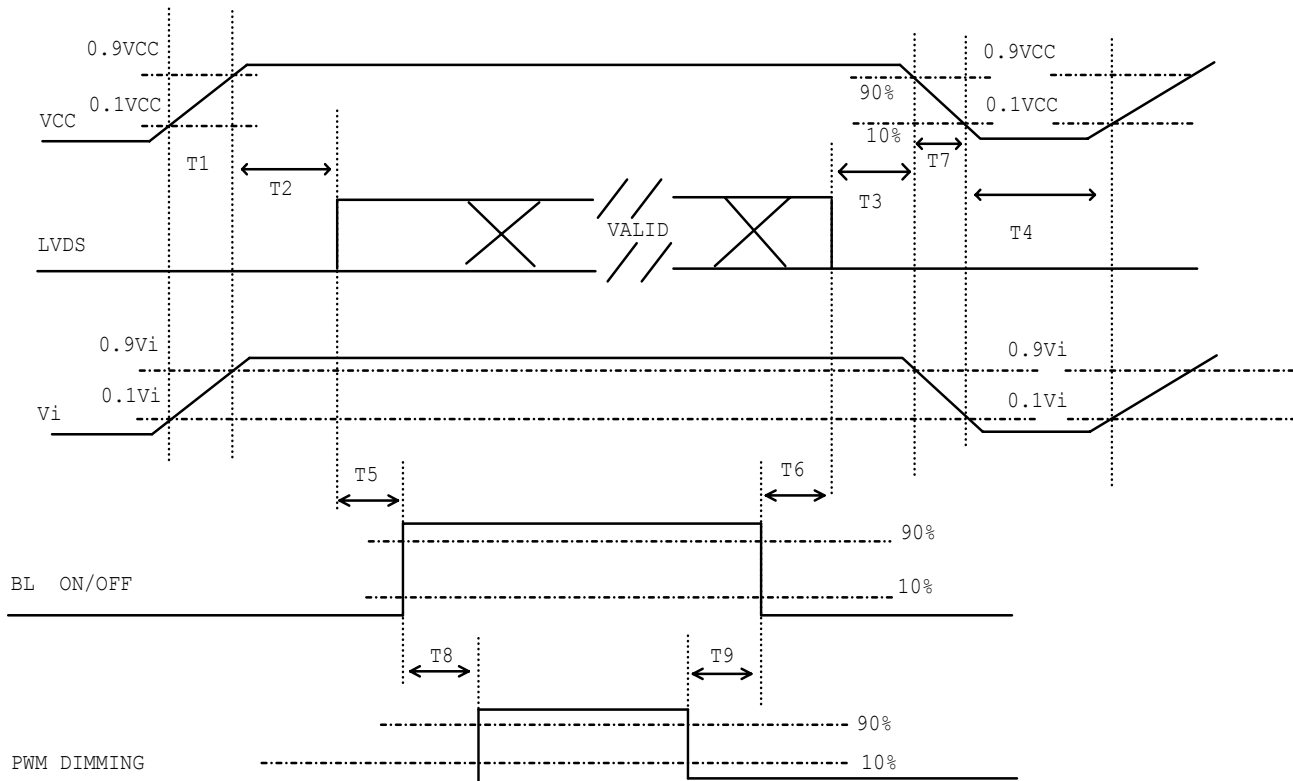

Power ON/OFF sequence

Note (1) Please avoid floating state of interface signal at invalid period.

Note (2) When the interface signal is invalid, be sure to pull down the power supply of LCD VCC to 0 V.

Note (3) The Backlight converter power must be turned on after the power supply for the logic and the interface signal is valid. The Backlight converter power must be turned off before the power supply for the logic and the interface signal is invalid.

Parameter	Value			Units
	Min	Typ	Max	
T1	0.5	---	10	ms
T2	0	---	50	ms
T3	0	---	50	ms
T4	500	---	---	ms
T5	200	---	---	ms
T6	20	---	---	ms
T7	5	---	300	ms
T8	10	---	---	ms
T9	10	---	---	ms

6.3 The Input Data Format

SEL 6/8="Low" or "NC" for 6 Bits LVDS



SEL 6/8="High" for 8 Bits LVDS



Note (1) R/G/B data 7: MSB, R/G/B data 0: LSB

Note (2) Please follow PSWG

Signal Name	Description	Remark
R7	Red Data 7 (MSB)	Red-pixel Data Each red pixel's brightness data consists of these 8 bits pixel data.
R6	Red Data 6	
R5	Red Data 5	
R4	Red Data 4	
R3	Red Data 3	
R2	Red Data 2	
R1	Red Data 1	
R0	Red Data 0 (LSB)	
G7	Green Data 7 (MSB)	Green-pixel Data Each green pixel's brightness data consists of these 8 bits pixel data.
G6	GreenData 6	
G5	GreenData 5	
G4	GreenData 4	
G3	GreenData 3	
G2	GreenData 2	
G1	GreenData 1	
G0	GreenData 0 (LSB)	
B7	Blue Data 7 (MSB)	Blue-pixel Data Each blue pixel's brightness data consists of these 8 bits pixel data.
B6	Blue Data 6	
B5	Blue Data 5	
B4	Blue Data 4	
B3	Blue Data 3	
B2	Blue Data 2	
B1	Blue Data 1	
B0	Blue Data 0 (LSB)	
RXCLKIN+ RXCLKIN-	LVDS Clock Input	
DE	Display Enable	
VS	Vertical Sync	
HS	Horizontal Sync	

7. OPTICAL CHARACTERISTICS

7.1 TEST CONDITIONS

Item	Symbol	Value	Unit
Ambient Temperature	T _a	25±2	°C
Ambient Humidity	H _a	50±10	%RH
Supply Voltage	V _{CC}	3.3	V
Input Signal	According to typical value in "3. ELECTRICAL CHARACTERISTICS"		
LED Light Bar Input Current	I _L	120	mA

The measurement methods of optical characteristics are shown in Section 7.2. The following items should be measured under the test conditions described in Section 7.1 and stable environment shown in Note (5).

7.2 OPTICAL SPECIFICATIONS

Item		Symbol	Condition	Min.	Typ.	Max.	Unit	Note		
Contrast Ratio		CR	$\theta_x=0^\circ, \theta_y=0^\circ$ Viewing Normal Angle	1000	1200	-	-	(2), (5)		
Response Time		T _R		-	15	20	ms	(3)		
		T _F		-	10	15	ms			
Luminance of White (5P)		L _{Ave}		300	400	-	cd/m ²	(4), (5)		
White Variation		δW		-	1.25	1.4	-	(5), (6)		
Color Chromaticity	Red	R _x		Viewing Normal Angle	Typ.- 0.05	Typ.+ 0.05	-	-	(1), (5)	
		R _y						0.565		-
	Green	G _x						0.352		-
		G _y						0.357		-
	Blue	B _x						0.581		-
		B _y	0.151					-		
	White	W _x	0.123					-		
		W _y	0.313					-		
Viewing Angle	Horizontal	θ_{x+}	CR≥10	80	88	-	Deg.	(1), (5)		
		θ_{x-}								
	Vertical	θ_{y+}								
		θ_{y-}								

Note (1) Definition of Viewing Angle (θ_x , θ_y):

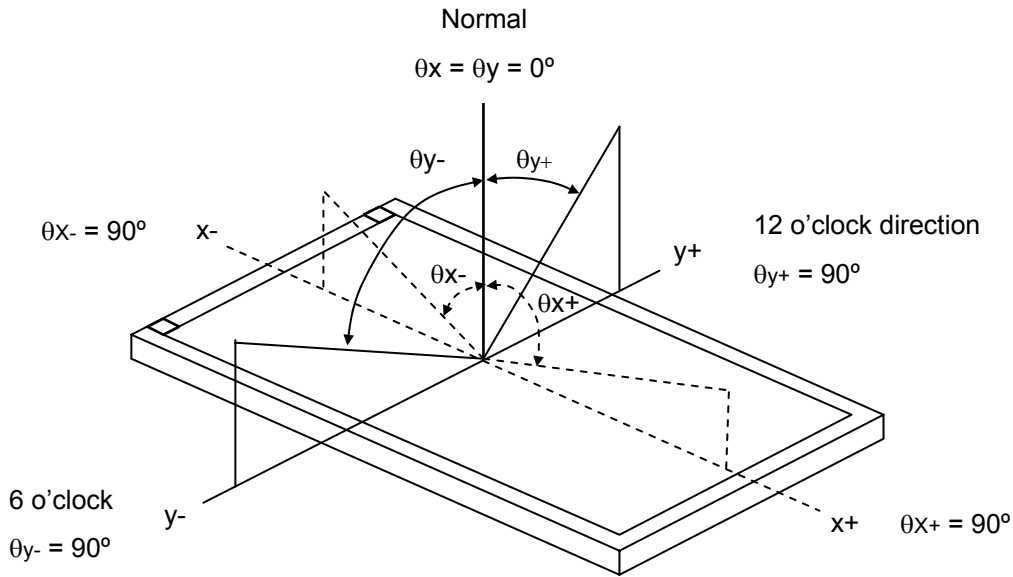

Note (2) Definition of Contrast Ratio (CR):

The contrast ratio can be calculated by the following expression.

$$\text{Contrast Ratio (CR)} = L_{63} / L_0$$

L63: Luminance of gray level 63

L 0: Luminance of gray level 0

$$\text{CR} = \text{CR} (5)$$

CR (X) is corresponding to the Contrast Ratio of the point X at Figure in Note (6).

Note (3) Definition of Response Time (T_R , T_F):

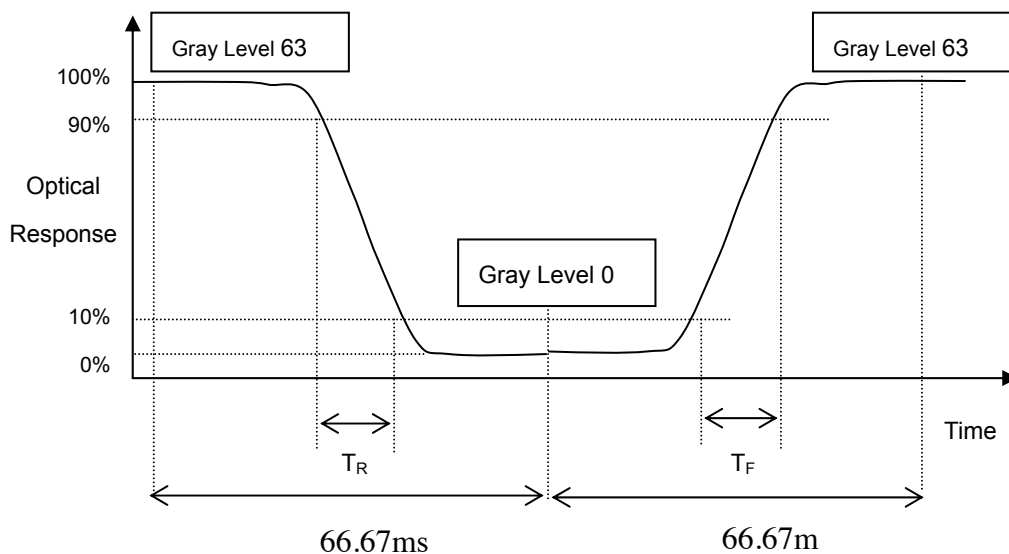

Note (4) Definition of Average Luminance of White (L_{AVE}):

Measure the luminance of gray level 63 at 5 points

$$L_{AVE} = [L(1) + L(2) + L(3) + L(4) + L(5)] / 5$$

$L(x)$ is corresponding to the luminance of the point X at Figure in Note (6).

Note (5) Measurement Setup:

The LCD module should be stabilized at given temperature for 15 minutes to avoid abrupt temperature change during measuring. In order to stabilize the luminance, the measurement should be executed after lighting Backlight for 15 minutes in a windless room.

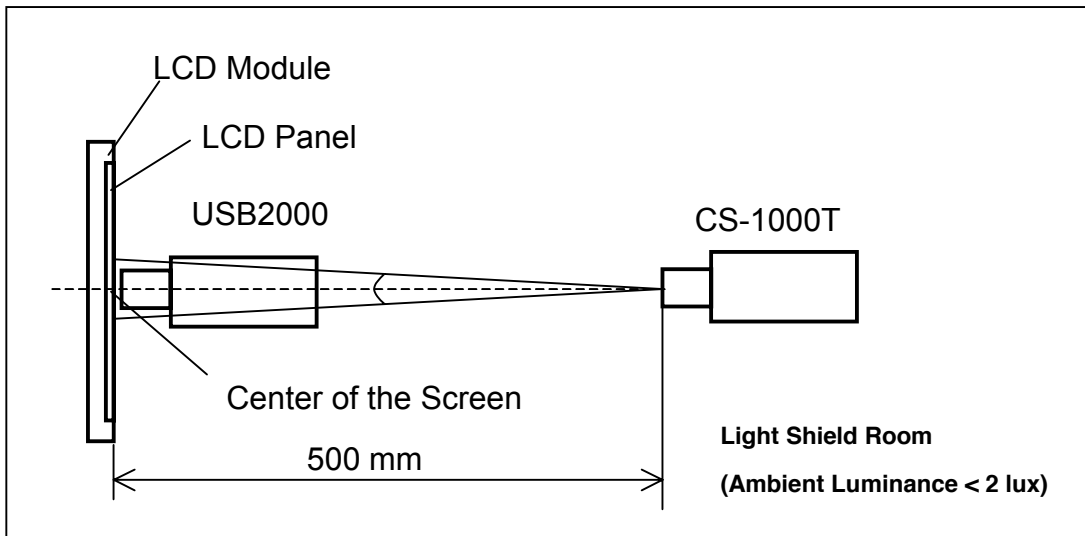

Note (6) Definition of White Variation (δW):

Measure the luminance of gray level 63 at 5 points

$$\delta W = \text{Maximum} [L(1), L(2), L(3), L(4), L(5)] / \text{Minimum} [L(1), L(2), L(3), L(4), L(5)]$$

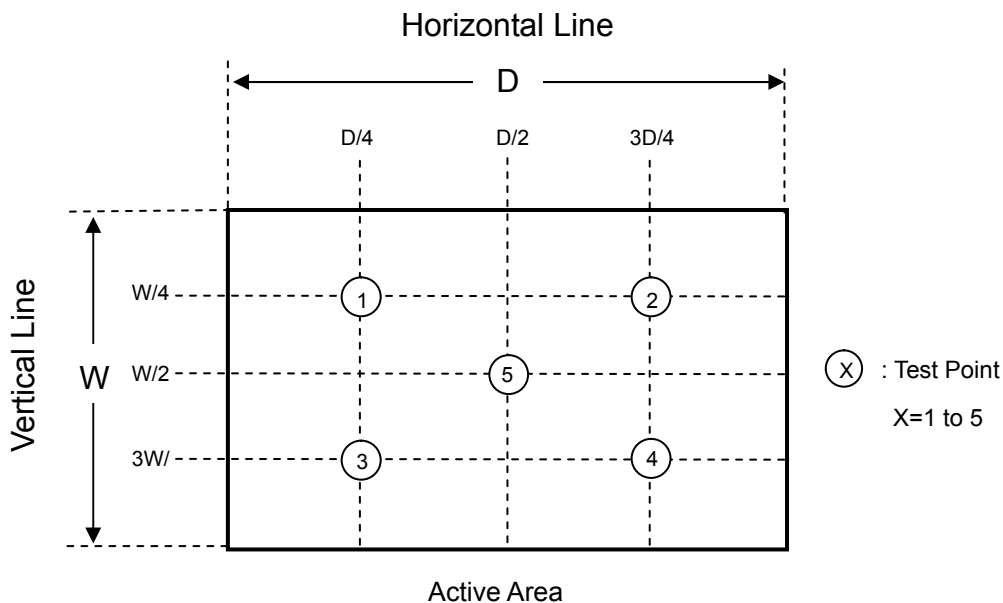

8. PRECAUTIONS

8.1 HANDLING PRECAUTIONS

- (1) The module should be assembled into the system firmly by using every mounting hole. Be careful not to twist or bend the module.
- (2) While assembling or installing modules, it can only be in the clean area. The dust and oil may cause electrical short or damage the polarizer.
- (3) Use fingerstalls or soft gloves in order to keep display clean during the incoming inspection and assembly process.
- (4) Do not press or scratch the surface harder than a HB pencil lead on the panel because the polarizer is very soft and easily scratched.
- (5) If the surface of the polarizer is dirty, please clean it by some absorbent cotton or soft cloth. Do not use Ketone type materials (ex. Acetone), Ethyl alcohol, Toluene, Ethyl acid or Methyl chloride. It might permanently damage the polarizer due to chemical reaction.
- (6) Wipe off water droplets or oil immediately. Staining and discoloration may occur if they left on panel for a long time.
- (7) If the liquid crystal material leaks from the panel, it should be kept away from the eyes or mouth. In case of contacting with hands, legs or clothes, it must be washed away thoroughly with soap.
- (8) Protect the module from static electricity, it may cause damage to the C-MOS Gate Array IC.
- (9) Do not disassemble the module.
- (10) Do not pull or fold the lamp wire.
- (11) Pins of I/F connector should not be touched directly with bare hands.

8.2 STORAGE PRECAUTIONS

- (1) High temperature or humidity may reduce the performance of module. Please store LCD module within the specified storage conditions.
- (2) It is dangerous that moisture come into or contacted the LCD module, because the moisture may damage LCD module when it is operating.
- (3) It may reduce the display quality if the ambient temperature is lower than 10 °C. For example, the response time will become slowly, and the starting voltage of lamp will be higher than the room temperature.

8.3 OPERATION PRECAUTIONS

- (1) Do not pull the I/F connector in or out while the module is operating.
- (2) Always follow the correct power on/off sequence when LCD module is connecting and operating. This can prevent the CMOS LSI chips from damage during latch-up.
- (3) The startup voltage of Backlight is approximately 1000 Volts. It may cause electrical shock while assembling with converter. Do not disassemble the module or insert anything into the Backlight unit.

8.4 OTHER PRECAUTIONS

- (1) When fixed patterns are displayed for a long time, remnant image is likely to occur.

9. PACKAGING

9.1 PACKING SPECIFICATIONS

- (1) 20pcs LCD modules / 1 Box
- (2) Box dimensions: 465 (L) X 362 (W) X 314 (H) mm
- (3) Weight: approximately 16Kg (20modules per box)

9.2 PACKING METHOD

- (1) Carton Packing should have no failure in the following reliability test items.

Test Item	Test Conditions	Note
Vibration	ISTA STANDARD Random, Frequency Range: 2 – 200 Hz Top & Bottom: 30 minutes (+Z), 10 min (-Z), Right & Left: 10 minutes (X) Back & Forth 10 minutes (Y)	Non Operation
Dropping Test	1 Angle, 3 Edge, 6 Face, 61 cm	Non Operation

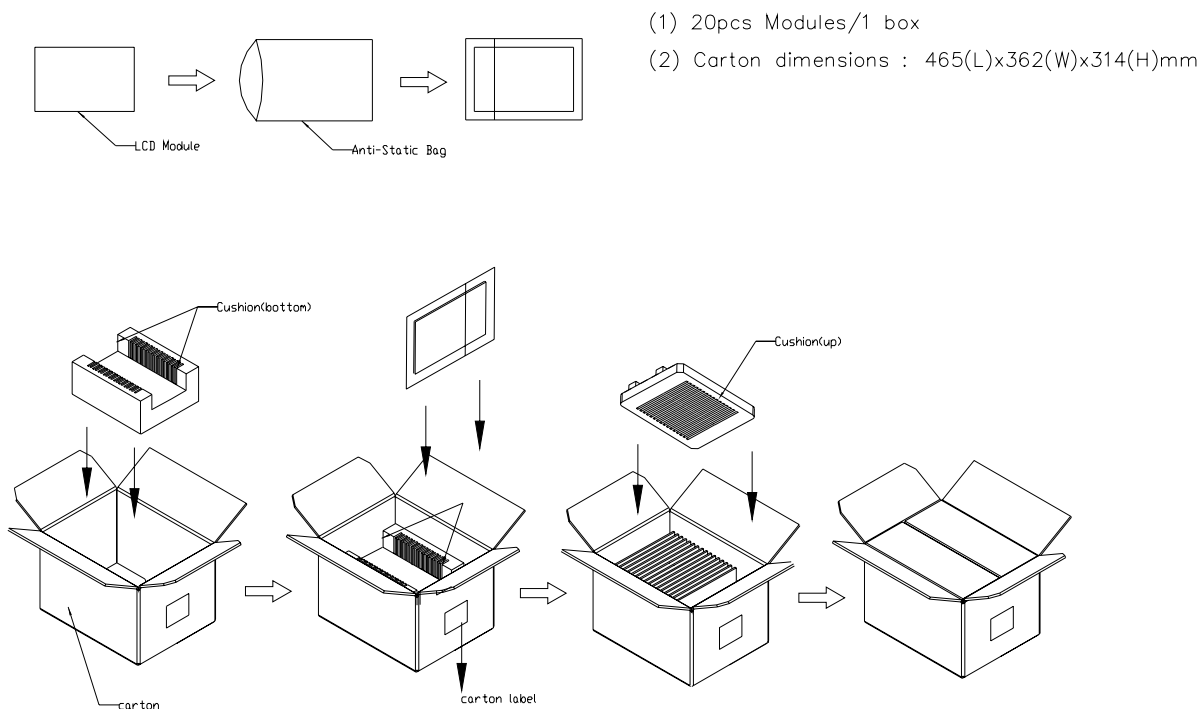
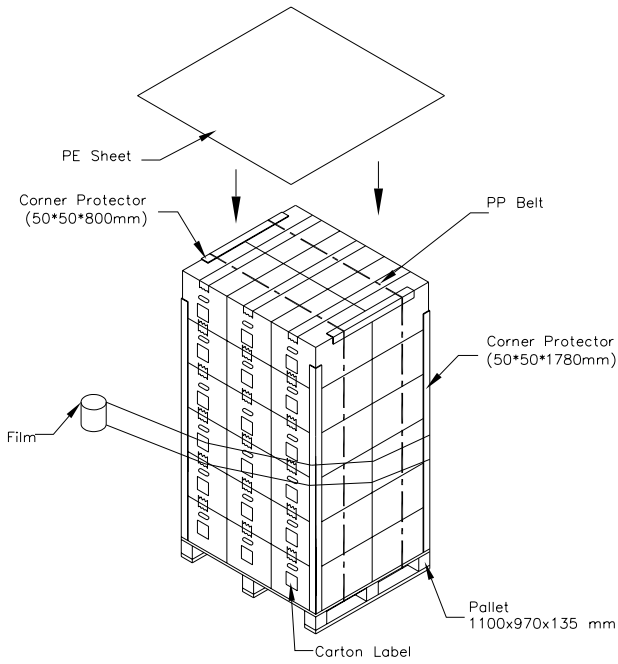

Figure. 9-1 Packing method

Sea / Land Transportation (40ft Container)



Air Transportation

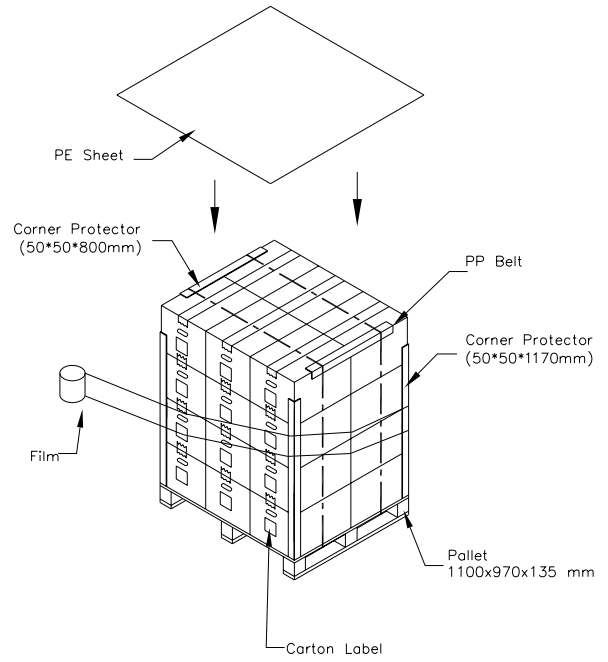

Figure. 9-2 Packing method
d

10. DEFINITION OF LABELS

10.1 CMO MODULE LABEL

The barcode nameplate is pasted on each module as illustration, and its definitions are as following explanation.



- (a) Model Name: G12111 - L01
- (b) Revision: Rev. XX, for example: A1, ..., C1, C2 ...etc.
- (c) Serial ID: XXXXXXYMDXXXX

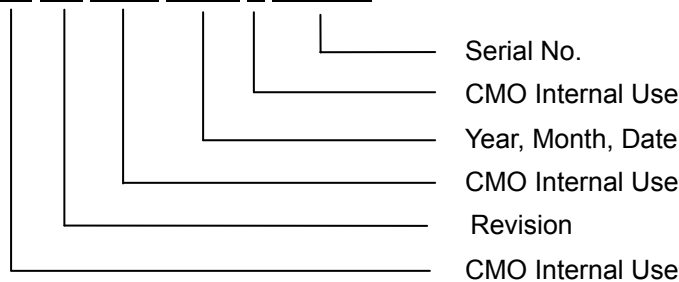

- (d) Production Location: MADE IN XXXX. XXXX stands for production location.
- (e) UL/CB logo: "LEOO" especially stands for panel manufactured by CMO Ningbo satisfying UL/CB requirement. "LEOO" is the CMO's UL factory code for Ningbo factory.

Serial ID includes the information as below:

- (a) Manufactured Date: Year: 1~9, for 2001~2009
 Month: 1~9, A~C, for Jan. ~ Dec.
 Day: 1~9, A~Y, for 1st to 31st, exclude I , O and U
- (b) Revision Code: cover all the change
- (c) Serial No.: Manufacturing sequence of product

HP CT label bar code definition:

- (a) C: Consistent display module code
- (b) AAAA: Consistent assembly code for this CMO model
- (c) 00: Revision code, begin from "01" and so on when version updated
- (d) DD: Production location code, VR stands for CMO Tainan, K5 stands for CMO NingBo
- (e) WW: production week
- (f) XXX: serial numbers

10.2 CARTON LABEL



CHI MEI OPTOELECTRONICS

PO.NO. _____

Part ID. _____

Model Name _____

Carton ID. _____ Quantities _____

Made in XXXX

GP
RoHS

- (a) P/N: Internal control
- (b) Model Name: G12111-L01
- (c) Production year and month: shown at left down corner
- (d) Production location: Made In XXXX. XXXX stands for production location.

11 Outline Dimension

