

TFT LCD Preliminary Specification

MODEL NO.: M156B1-L01

Customer: _____
Approved by: _____
Note: For Reference Only

Liquid Crystal Display Division	
QRA Division	OA Head Division
Approval	Approval

- CONTENTS -

REVISION HISTORY	3
1. GENERAL DESCRIPTION	4
1.1 OVERVIEW	
1.2 FEATURES	
1.3 APPLICATION	
1.4 GENERAL SPECIFICATIONS	
1.5 MECHANICAL SPECIFICATIONS	
2. ABSOLUTE MAXIMUM RATINGS	5
2.1 ABSOLUTE RATINGS OF ENVIRONMENT	
2.2 ELECTRICAL ABSOLUTE RATINGS	
2.2.1 TFT LCD MODULE	
2.2.2 BACKLIGHT UNIT	
3. ELECTRICAL CHARACTERISTICS	7
3.1.1 TFT LCD MODULE	
3.1.2 Vcc Power Dip Condition:	
3.2 BACKLIGHT UNIT	
4. BLOCK DIAGRAM.....	11
4.1 TFT LCD MODULE	
4.2 BACKLIGHT UNIT	
5. INPUT TERMINAL PIN ASSIGNMENT	12
5.1 TFT LCD MODULE	
5.2 LVDS DATA MAPPING TABLE	
5.3 BACKLIGHT UNIT	
5.4 COLOR DATA INPUT ASSIGNMENT	
6. INTERFACE TIMING	15
6.1 INPUT SIGNAL TIMING SPECIFICATIONS	
6.2 POWER ON/OFF SEQUENCE	
7. OPTICAL CHARACTERISTICS.....	17
7.1 TEST CONDITIONS	
7.2 OPTICAL SPECIFICATIONS	
8. PACKAGING	21
8.1 PACKING SPECIFICATIONS	
8.2 PACKING METHOD	
9. DEFINITION OF LABELS.....	23
10. PRECAUTIONS.....	24
10.1 ASSEMBLY AND HANDLING PRECAUTIONS	
10.2 SAFETY PRECAUTIONS	
11. MECHANICAL CHARACTERISTICS	25

REVISION HISTORY

Version	Date	Section	Description
Ver 1.0	Sep. 28, 07'	-	M156B1-L01 Preliminary specification was first issued.

1. GENERAL DESCRIPTION

1.1 OVERVIEW

M156B1-L01 is a 15.6" TFT Liquid Crystal Display module with 2 CCFL Backlight unit and 30pin 1ch-LVDS interface. This module supports 1366 x 768 WXGA mode and can display up to 16.7M colors. The inverter module for Backlight is not built in.

1.2 FEATURES

- Contrast ratio 500:1
- Response time 8ms.
- Brightness 250nits
- Color saturation NTSC 65%.
- WXGA (1366 x 768 pixels) resolution.
- DE (Data Enable) only mode.
- LVDS (Low Voltage Differential Signaling) interface.
- RoHS compliance.
- TCO'03 compliance.

1.3 APPLICATION

- TFT LCD Monitor

1.4 GENERAL SPECIFICATIONS

Item	Specification	Unit	Note
Active Area	344.232(H) × 193.536(V) (15.6" diagonal)	mm	(1)
Bezel Opening Area	347.5(H)×196.8(V)	mm	
Driver Element	a-Si TFT active matrix	-	-
Pixel Number	1366 x R.G.B. x 768	pixel	-
Pixel Pitch	0.252 (H) x 0.252 (V)	mm	-
Pixel Arrangement	RGB vertical stripe	-	-
Display Colors	16.7M	color	-
Transmissive Mode	Normally White	-	-
Surface Treatment	AG type, 3H hard coating, Haze 25	-	-

1.5 MECHANICAL SPECIFICATIONS

Item	Min.	Typ.	Max.	Unit	Note	
Module Size	Horizontal(H)	363.3	363.8	364.3	mm	(1)
	Vertical(V)	215.4	215.9	216.4	mm	
	Depth(D)	13.8	14.3	14.8	mm	
Weight	-	-	1300	g	-	

Note (1) Please refer to the attached drawings for more information of front and back outline dimensions.

2. ABSOLUTE MAXIMUM RATINGS

2.1 ABSOLUTE RATINGS OF ENVIRONMENT

Item	Symbol	Value		Unit	Note
		Min.	Max.		
Storage Temperature	T _{ST}	-20	60	°C	(1)
Operating Ambient Temperature	T _{OP}	0	50	°C	(1), (2)
Shock (Non-Operating)	S _{NOP}	-	50	G	(3), (5)
Vibration (Non-Operating)	V _{NOP}	-	1.5	G	(4), (5)

Note (1) Temperature and relative humidity range is shown in the figure below.

- (a) 90 %RH Max. ($T_a \leq 40$ °C).
- (b) Wet-bulb temperature should be 39 °C Max. ($T_a > 40$ °C).
- (c) No condensation.

Note (2) The temperature of panel display surface area should be 0 °C Min. and 60 °C Max.

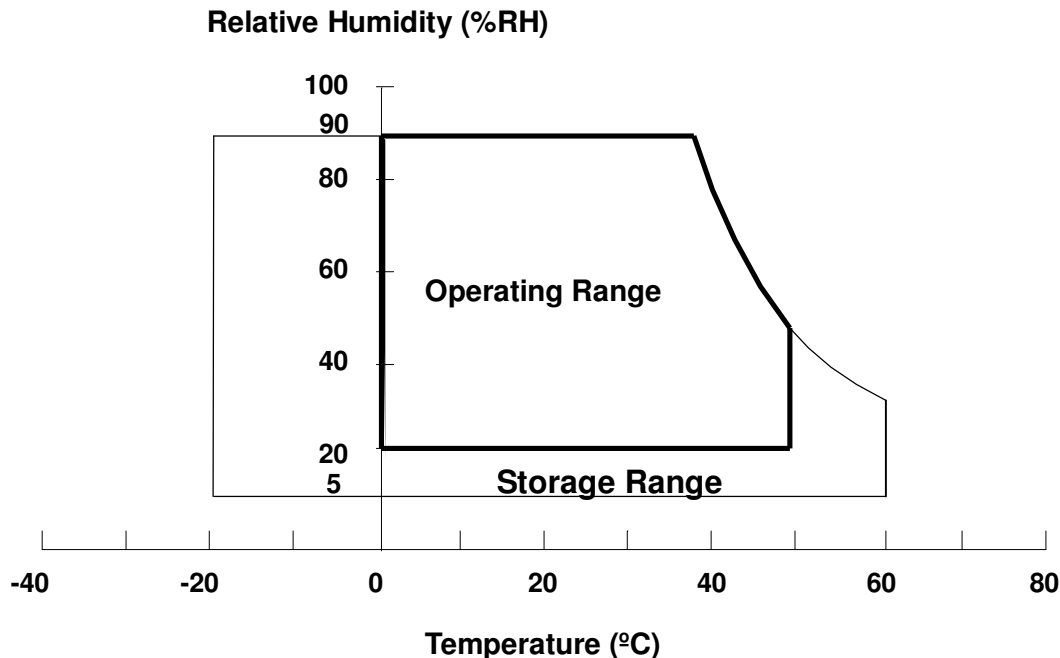

Note (3) 11ms, half sine wave, 1 time for $\pm X, \pm Y, \pm Z$.

Note (4) 10 ~ 300 Hz, 10min/cycle, 3 cycles each X, Y, Z.

Note (5) At testing Vibration and Shock, the fixture in holding the module has to be hard and rigid enough so that the module would not be twisted or bent by the fixture.

The fixing condition is shown as below:

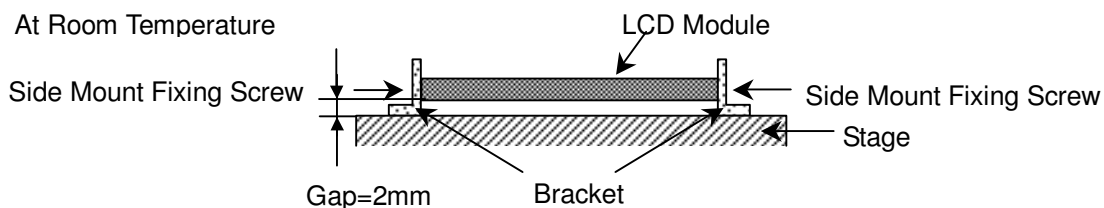

2.2 ELECTRICAL ABSOLUTE RATINGS

2.2.1 TFT LCD MODULE

Item	Symbol	Value		Unit	Note
		Min.	Max.		
Power Supply Voltage	Vcc	-0.3	+6.0	V	(1)

2.2.2 BACKLIGHT UNIT

Item	Symbol	Value		Unit	Note
		Min.	Max.		
Lamp Voltage	V_L	TBD	TBD	V_{RMS}	(1), (2)
Lamp Current	I_L	(3)	(8)	mA_{RMS}	(1), (2) also see page.10
Lamp Frequency	F_L	(50)	(60)	KHz	Note(7)

Note (1) Permanent damage to the device may occur if maximum values are exceeded. Function operation should be restricted to the conditions described under Normal Operating Conditions.

Note (2) Specified values are for lamp (Refer to 3.2 for further information).

3. ELECTRICAL CHARACTERISTICS

3.1.1 TFT LCD MODULE

Ta = 25 ± 2 °C

Parameter	Symbol	Value			Unit	Note
		Min.	Typ.	Max.		
Power Supply Voltage	V _{CC}	4.5	5.0	5.5	V	-
Ripple Voltage	V _{RP}	-	-	100	mV	-
Rush Current	I _{RUSH}			(1.5)	A	(2)
Power Supply Current	White	-	(0.3)	(0.35)	A	(3)a
	Black	-	(0.35)	(0.41)	A	(3)b
	Vertical Stripe	-	(0.4)	(0.43)	A	(3)c
LVDS differential input voltage	V _{id}	100	-	600	mV	
LVDS common input voltage	V _{ic}	-	1.2	-	V	

Note (1) The module should be always operated within above ranges.

Note (2) Measurement Conditions:

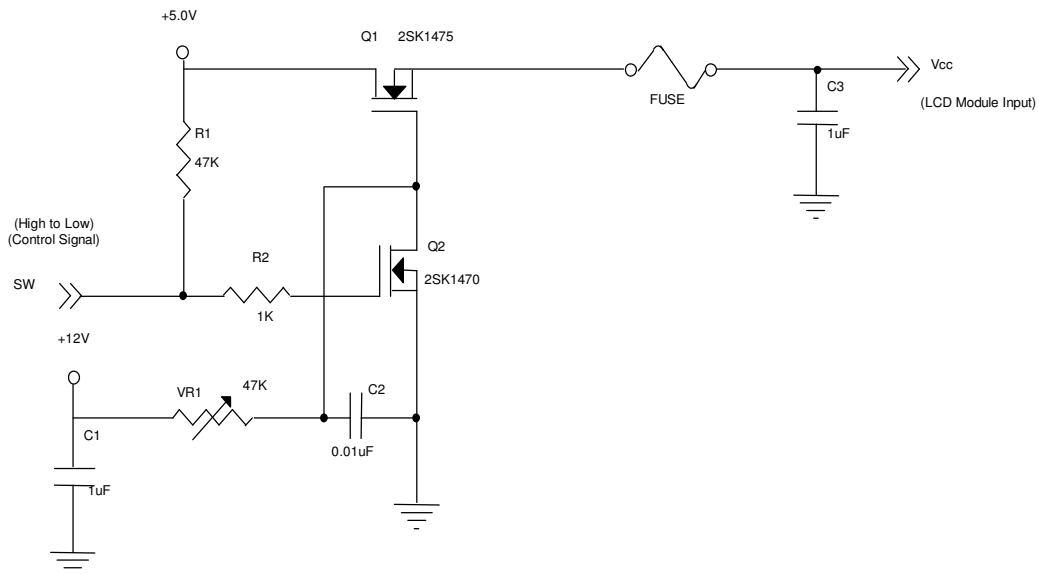

Vcc rising time is 470μs

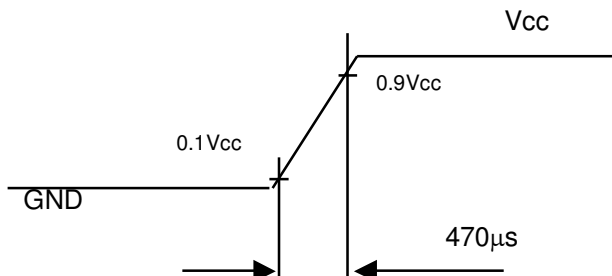

Note (3) The specified power supply current is under the conditions at $V_{cc} = 5.0\text{ V}$, $T_a = 25 \pm 2\text{ }^\circ\text{C}$, $f_v = 60\text{ Hz}$, whereas a power dissipation check pattern below is displayed.

a. White Pattern



Active Area

b. Black Pattern



Active Area

c. Vertical Stripe Pattern

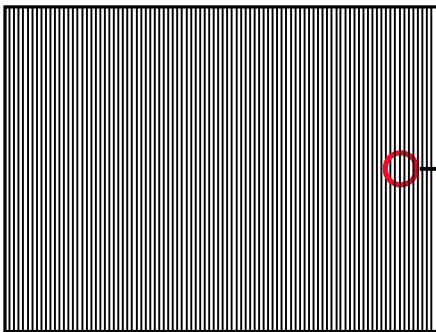

Active Area

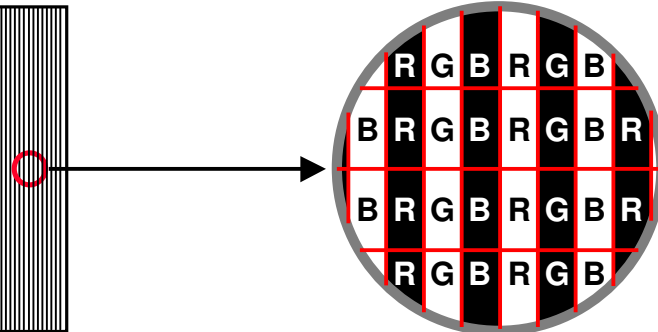

3.1.2 V_{cc} Power Dip Condition:

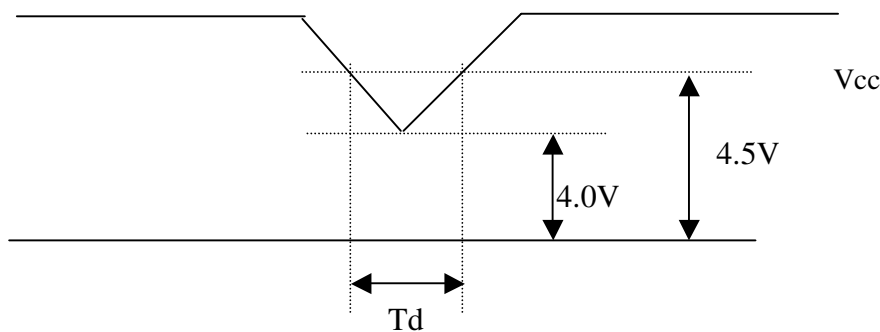

Dip condition: $4.0\text{V} \leq V_{cc} \leq 4.5\text{V}$, $T_d \leq 20\text{ms}$

3.2 BACKLIGHT UNIT

Ta = 25 ± 2 °C

Parameter	Symbol	Value			Unit	Note
		Min.	Typ.	Max.		
Lamp Input Voltage	V _L	(560)	(660)	(760)	V _{RMS}	I _L = 7.0 mA
Lamp Current	I _L	(3.0)	(7.0)	(8.0)	mA _{RMS}	(1)
Lamp Turn On Voltage	V _S			(1520 (0°C))	V _{RMS}	(2)
				(1490 (25°C))	V _{RMS}	(2)
Operating Frequency	F _L	(50)	(55)	(60)	KHz	(3)(7)
Lamp Life Time	L _{BL}	50,000			Hrs	(5), I _L = 7.0mA
Power Consumption	P _L		(9.24)		W	(4), I _L = 7.0 mA

Note (1) Lamp current is measured by current amplify & oscilloscope as shown below:

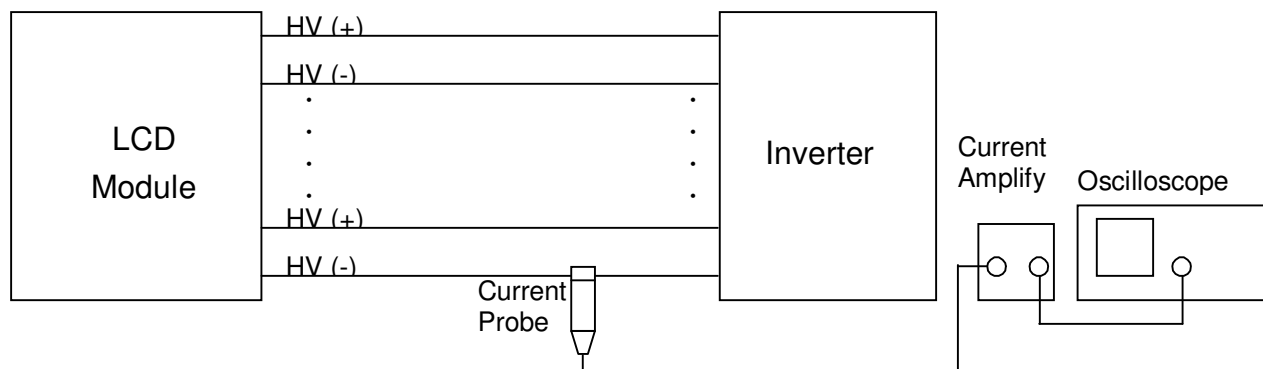

Measure equipment:
 Current Amplify: Tektronix TCPA300
 Current probe: Tektronix TCP312
 Oscilloscope: TDS3054B

Note (2) The voltage that must be larger than V_S should be applied to the lamp for more than 1 second after startup. Otherwise, the lamp may not be turned on normally.

Note (3) The lamp frequency may produce interference with horizontal synchronization frequency from the display, which might cause line flow on the display. In order to avoid interference, the lamp frequency should be detached from the horizontal synchronization frequency and its harmonics as far as possible.

Note (4) P_L = I_L × V_L × 2 (for 2 lamps)

Note (5) The lifetime of lamp can be defined as the time in which it continues to operate under the condition Ta = 25 ± 2 °C and I_L = 7.0 mA_{RMS} until one of the following events occurs:

(a) When the brightness becomes ≤ 50% of its original value.

(b) When the effective ignition length becomes ≤ 80% of its original value.

(The effective ignition length is a scope that luminance is over 80% of that at the center point.)

Note (6) The waveform of the voltage output of inverter must be area-symmetric and the design of the inverter must have specifications for the modularized lamp. The performance of the Backlight, such as lifetime or brightness, is greatly influenced by the characteristics of the DC-AC inverter for the lamp. All the parameters of an inverter should be carefully designed to avoid producing too much current leakage from high voltage output of the inverter. When designing or ordering the

inverter please make sure that a poor lighting caused by the mismatch of the Backlight and the inverter (miss-lighting, flicker, etc.) never occurs. If the above situation is confirmed, the module should be operated in the same manners when it is installed in your instrument.

The output of the inverter must have symmetrical (negative and positive) voltage waveform and symmetrical current waveform. (Unsymmetrical ratio is less than 10%) Please do not use the inverter which has unsymmetrical voltage and unsymmetrical current and spike wave. Lamp frequency may produce interface with horizontal synchronous frequency and as a result this may cause beat on the display. Therefore lamp frequency shall be as away possible from the horizontal synchronous frequency and from its harmonics in order to prevent interference.

Requirements for a system inverter design, which is intended to have a better display performance, a better power efficiency and a more reliable lamp. It shall help increase the lamp lifetime and reduce its leakage current.

- a. The asymmetry rate of the inverter waveform should be 10% below;
- b. The distortion rate of the waveform should be within $\sqrt{2} \pm 10\%$;
- c. The ideal sine wave form shall be symmetric in positive and negative polarities

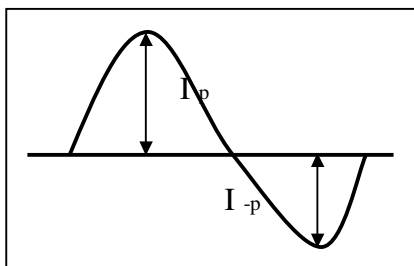

* Asymmetry rate:

$$\frac{|I_p - I_{-p}|}{I_{rms}} * 100\%$$

* Distortion rate

$$I_p \text{ (or } I_{-p}) / I_{rms}$$

Note (7) 50~60KHz, the frequency range can guarantee the optical and electrical characteristics; 40~80KHz the frequency range will not effect the Lifetime and reliability characteristics.

4. BLOCK DIAGRAM

4.1 TFT LCD MODULE

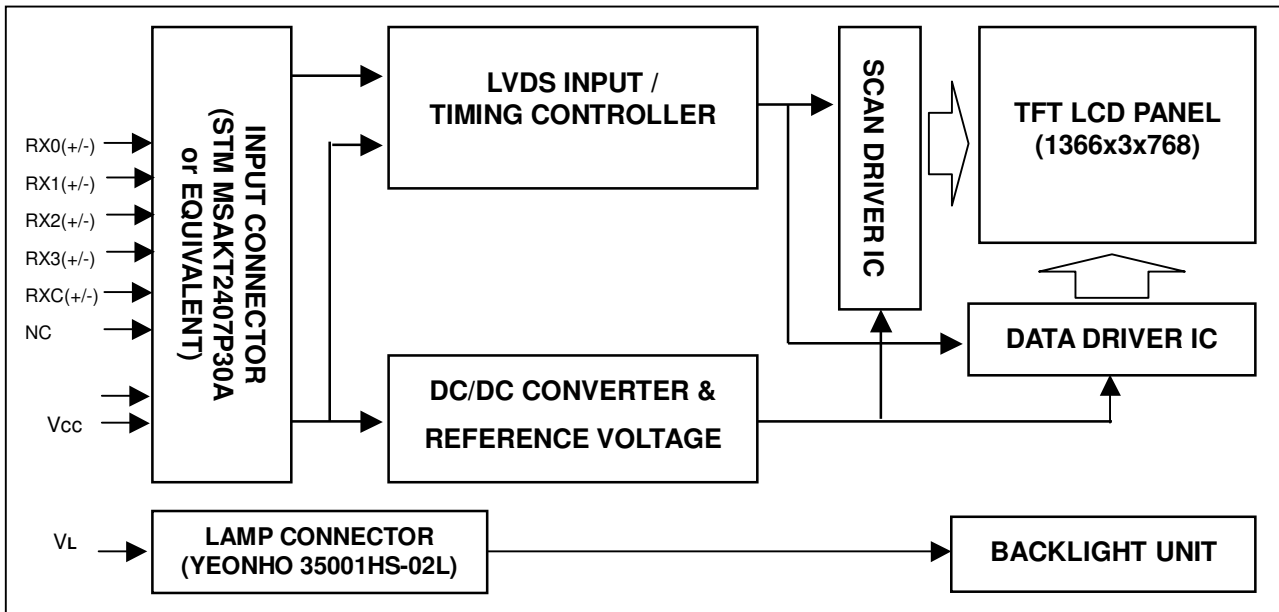

4.2 BACKLIGHT UNIT

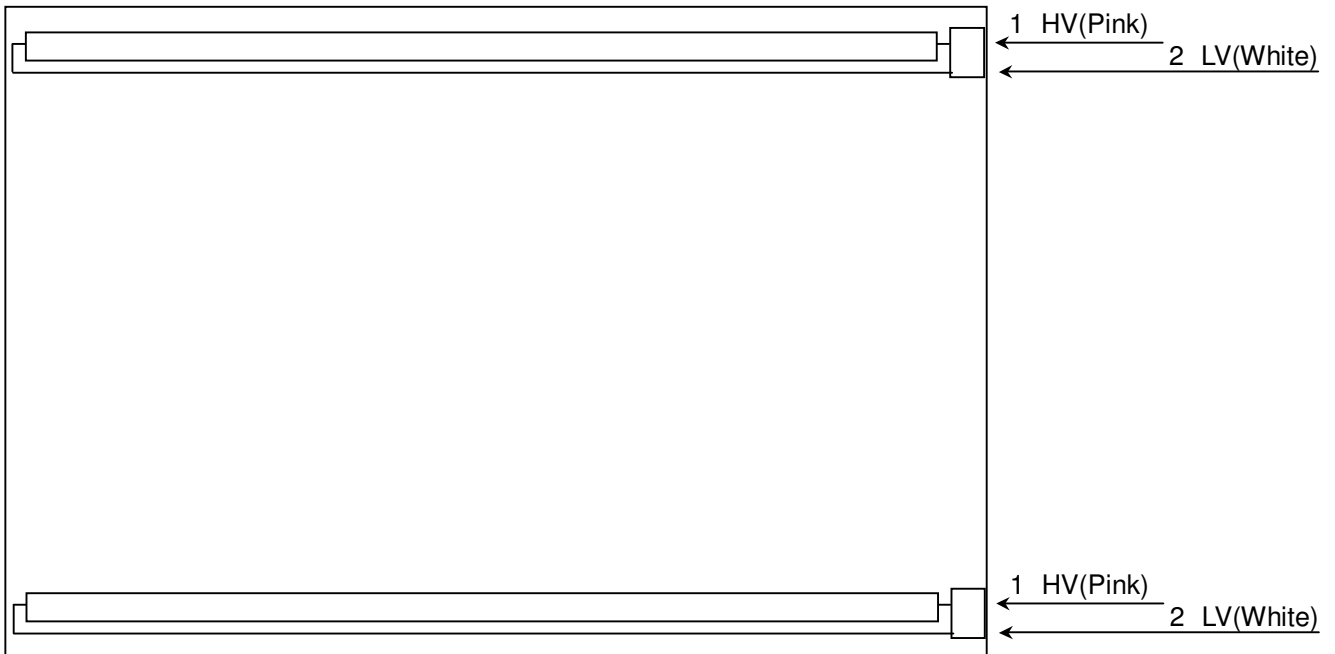

5. INPUT TERMINAL PIN ASSIGNMENT

5.1 TFT LCD MODULE

Pin	Name	Description
1	NC	Not connection, this pin should be open.
2	NC	Not connection, this pin should be open.
3	NC	Not connection, this pin should be open.
4	GND	Ground
5	RX0-	Negative LVDS differential data input. Channel 0
6	RX0+	Positive LVDS differential data input. Channel 0
7	GND	Ground
8	RX1-	Negative LVDS differential data input. Channel 1
9	RX1+	Positive LVDS differential data input. Channel 1
10	GND	Ground
11	RX2-	Negative LVDS differential data input. Channel 2
12	RX2+	Positive LVDS differential data input. Channel 2
13	GND	Ground
14	RXCLK-	Negative LVDS differential clock input.
15	RXCLK+	Positive LVDS differential clock input.
16	GND	Ground
17	RX3-	Negative LVDS differential data input. Channel 3
18	RX3+	Positive LVDS differential data input. Channel 3
19	GND	Ground
20	NC	Not connection, this pin should be open.
21	NC	Not connection, this pin should be open.
22	NC	Reserved. (For internal test used)
23	GND	Ground
24	GND	Ground
25	GND	Ground
26	VCC	+5.0V power supply
27	VCC	+5.0V power supply
28	VCC	+5.0V power supply
29	VCC	+5.0V power supply
30	VCC	+5.0V power supply

Note (1) Connector Part No.: STM MSAKT2407P30A or STARCONN 093G30-B0001A

5.2 LVDS mapping table

LVDS Channel 0	LVDS output	D7	D6	D4	D3	D2	D1	D0
	Data order	G0	R5	R4	R3	R2	R1	R0
LVDS Channel 1	LVDS output	D18	D15	D14	D13	D12	D9	D8
	Data order	B1	B0	G5	G4	G3	G2	G1
LVDS Channel 2	LVDS output	D26	D25	D24	D22	D21	D20	D19
	Data order	DE	NA	NA	B5	B4	B3	B2
LVDS Channel 3	LVDS output	D23	D17	D16	D11	D10	D5	D27
	Data order	NA	B7	B6	G7	G6	R7	R6

5.3 BACKLIGHT UNIT:

Pin	Symbol	Description	Remark
1	HV	High Voltage	Pink
2	LV	Low Voltage	White

Note (1) Connector Part No.: YEONHO 20015HS-04LB or equivalent

5.4 COLOR DATA INPUT ASSIGNMENT

The brightness of each primary color (red, green and blue) is based on the 8-bit gray scale data input for the color. The higher the binary input, the brighter the color. The table below provides the assignment of color versus data input.

Color		Data Signal																						
		Red								Green								Blue						
		R7	R6	R5	R4	R3	R2	R1	R0	G7	G6	G5	G4	G3	G2	G1	G0	B7	B6	B5	B4	B3	B2	B1
Basic Colors	Black	0	0	0	0	0	0	0	0	0	0	0	0	0	0	0	0	0	0	0	0	0	0	0
	Red	1	1	1	1	1	1	1	1	0	0	0	0	0	0	0	0	0	0	0	0	0	0	0
	Green	0	0	0	0	0	0	0	0	1	1	1	1	1	1	1	1	0	0	0	0	0	0	0
	Blue	0	0	0	0	0	0	0	0	0	0	0	0	0	0	0	0	1	1	1	1	1	1	1
	Cyan	0	0	0	0	0	0	0	0	1	1	1	1	1	1	1	1	1	1	1	1	1	1	1
	Magenta	1	1	1	1	1	1	1	1	0	0	0	0	0	0	0	0	1	1	1	1	1	1	1
	Yellow	1	1	1	1	1	1	1	1	1	1	1	1	1	1	1	1	0	0	0	0	0	0	0
	White	1	1	1	1	1	1	1	1	1	1	1	1	1	1	1	1	1	1	1	1	1	1	1
Gray Scale Of Red	Red(0) / Dark	0	0	0	0	0	0	0	0	0	0	0	0	0	0	0	0	0	0	0	0	0	0	
	Red(1)	0	0	0	0	0	0	0	1	0	0	0	0	0	0	0	0	0	0	0	0	0	0	
	Red(2)	0	0	0	0	0	0	1	0	0	0	0	0	0	0	0	0	0	0	0	0	0	0	
	:	:	:	:	:	:	:	:	:	:	:	:	:	:	:	:	:	:	:	:	:	:	:	
	:	:	:	:	:	:	:	:	:	:	:	:	:	:	:	:	:	:	:	:	:	:	:	
	:	:	:	:	:	:	:	:	:	:	:	:	:	:	:	:	:	:	:	:	:	:	:	
	Red(253)	1	1	1	1	1	1	0	1	0	0	0	0	0	0	0	0	0	0	0	0	0	0	
	Red(254)	1	1	1	1	1	1	1	0	0	0	0	0	0	0	0	0	0	0	0	0	0	0	
Red(255)	1	1	1	1	1	1	1	1	0	0	0	0	0	0	0	0	0	0	0	0	0	0		
Gray Scale Of Green	Green(0) / Dark	0	0	0	0	0	0	0	0	0	0	0	0	0	0	0	0	0	0	0	0	0	0	
	Green(1)	0	0	0	0	0	0	0	0	0	0	0	0	0	0	1	0	0	0	0	0	0	0	
	Green(2)	0	0	0	0	0	0	0	0	0	0	0	0	0	1	0	0	0	0	0	0	0	0	
	:	:	:	:	:	:	:	:	:	:	:	:	:	:	:	:	:	:	:	:	:	:	:	
	:	:	:	:	:	:	:	:	:	:	:	:	:	:	:	:	:	:	:	:	:	:	:	
	:	:	:	:	:	:	:	:	:	:	:	:	:	:	:	:	:	:	:	:	:	:	:	
	Green(253)	0	0	0	0	0	0	0	1	1	1	1	1	1	0	1	0	0	0	0	0	0	0	
	Green(254)	0	0	0	0	0	0	0	1	1	1	1	1	1	1	0	0	0	0	0	0	0	0	
Green(255)	0	0	0	0	0	0	0	1	1	1	1	1	1	1	1	0	0	0	0	0	0	0		
Gray Scale Of Blue	Blue(0) / Dark	0	0	0	0	0	0	0	0	0	0	0	0	0	0	0	0	0	0	0	0	0	0	
	Blue(1)	0	0	0	0	0	0	0	0	0	0	0	0	0	0	0	0	0	0	0	0	0	1	
	Blue(2)	0	0	0	0	0	0	0	0	0	0	0	0	0	0	0	0	0	0	0	0	0	1	
	:	:	:	:	:	:	:	:	:	:	:	:	:	:	:	:	:	:	:	:	:	:	:	
	:	:	:	:	:	:	:	:	:	:	:	:	:	:	:	:	:	:	:	:	:	:	:	
	:	:	:	:	:	:	:	:	:	:	:	:	:	:	:	:	:	:	:	:	:	:	:	
	Blue(253)	0	0	0	0	0	0	0	0	0	0	0	0	0	0	1	1	1	1	1	1	1	0	
	Blue(254)	0	0	0	0	0	0	0	0	0	0	0	0	0	0	1	1	1	1	1	1	1	0	
Blue(255)	0	0	0	0	0	0	0	0	0	0	0	0	0	0	1	1	1	1	1	1	1	1		

Note (1) 0: Low Level Voltage, 1: High Level Voltage

6. INTERFACE TIMING

6.1 INPUT SIGNAL TIMING SPECIFICATIONS

The input signal timing specifications are shown as the following table and timing diagram.

Signal	Item	Symbol	Min.	Typ.	Max.	Unit	Note
LVDS Clock	Frequency	F_c	50.0	(76)	(85)	MHz	-
	Period	T_c	-	13.0	-	ns	-
	High Time	T_{ch}	-	4/7	-	T_c	-
	Low Time	T_{cl}	-	3/7	-	T_c	-
LVDS Data	Setup Time	T_{lvs}	600	-	-	ps	-
	Hold Time	T_{lvh}	600	-	-	ps	-
Vertical Active Display Term	Frame Rate	F_r	40	60	(75)	Hz	$T_v = T_{vd} + T_{vb}$
	Total	T_v	(778)	(806)	(888)	T_h	-
	Display	T_{vd}	768	768	768	T_h	-
	Blank	T_{vb}	$T_v - T_{vd}$	(38)	$T_v - T_{vd}$	T_h	-
Horizontal Active Display Term	Total	T_h	(1446)	(1560)	(1936)	T_c	$T_h = T_{hd} + T_{hb}$
	Display	T_{hd}	1366	1366	1366	T_c	-
	Blank	T_{hb}	$T_h - T_{hd}$	(194)	$T_h - T_{hd}$	T_c	-

Note: Because this module is operated by DE only mode, Hsync and Vsync input signals should be set to low logic level or ground. Otherwise, this module would operate abnormally.

INPUT SIGNAL TIMING DIAGRAM

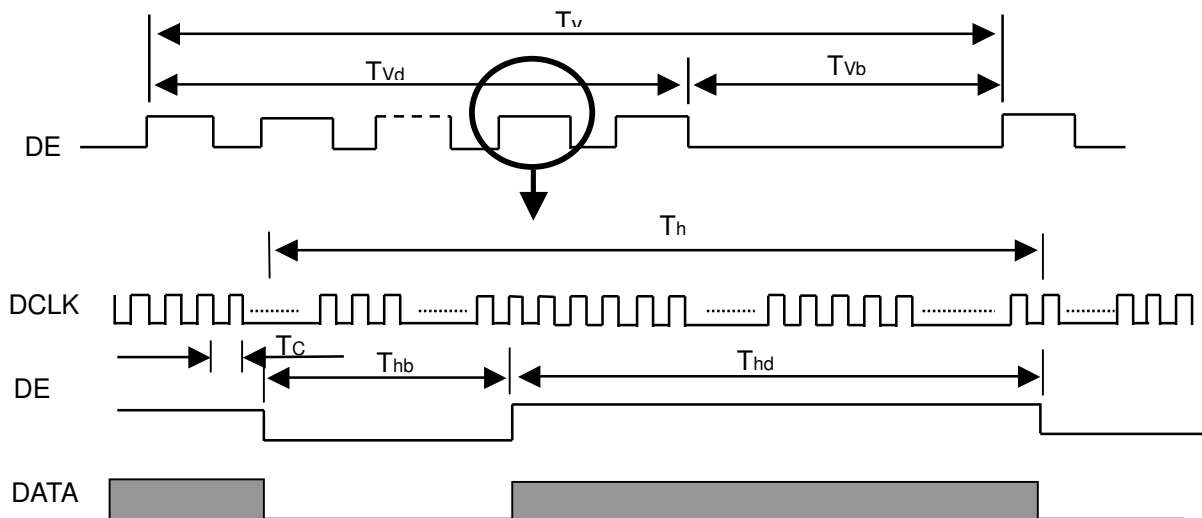

6.2 POWER ON/OFF SEQUENCE

To prevent a latch-up or DC operation of LCD module, the power on/off sequence should be as the diagram below.

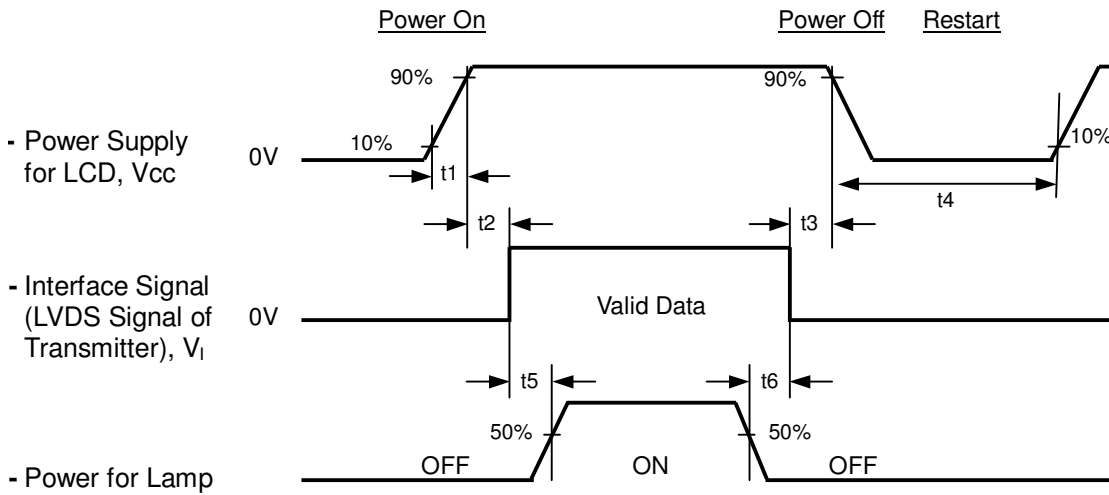

Timing Specifications:

- $0.5 < t1 \leq 10 \text{ msec}$
- $0 < t2 \leq 50 \text{ msec}$
- $0 < t3 \leq 50 \text{ msec}$
- $t4 \geq 500 \text{ msec}$
- $t5 \geq 450 \text{ msec}$
- $t6 \geq 90 \text{ msec}$

7. OPTICAL CHARACTERISTICS

7.1 TEST CONDITIONS

Item	Symbol	Value	Unit
Ambient Temperature	T _a	25±2	°C
Ambient Humidity	H _a	50±10	%RH
Supply Voltage	V _{CC}	5V	V
Input Signal	According to typical value in "3. ELECTRICAL CHARACTERISTICS"		
Lamp Current	I _L	(7.0)	mA
Inverter Operating Frequency	F _L	(55±5)	KHz
Inverter	(Darfon VK12164.101)		

7.2 OPTICAL SPECIFICATIONS

The relative measurement methods of optical characteristics are shown in 7.2. The following items should be measured under the test conditions described in 7.1 and stable environment shown in Note (5).

Item	Symbol	Condition	Min.	Typ.	Max.	Unit	Note	
Color Chromaticity (CIE 1931)	Red	$\theta_x=0^\circ, \theta_y=0^\circ$ CS-1000T	Typ - 0.03	0.637	Typ + 0.03	-	(1), (5)	
								Ry
	Green							Gx
								Gy
	Blue							Bx
								By
	White							Wx
								Wy
Center Luminance of White (Center of Screen)	L _c		(210)	250	-	cd/m ²	(4), (5)	
Contrast Ratio	CR		(350)	(500)	-	-	(2), (5)	
Response Time	T _R	$\theta_x=0^\circ, \theta_y=0^\circ$	-	(2)	(4)	ms	(3), (7)	
	T _F		-	(6)	(12)			
	T _{GIG AVE}		-	-	-			
White Variation	δW	$\theta_x=0^\circ, \theta_y=0^\circ$ USB2000	-	(1.4)	(1.5)	-	(5), (6)	
Viewing Angle	Horizontal	CR ≥ 10 BM5A	40	45	-	Deg.	(1), (5)	
			40	45	-			
	Vertical		15	20	-			
			40	45	-			

Note (1) Definition of Viewing Angle (θ_x, θ_y):

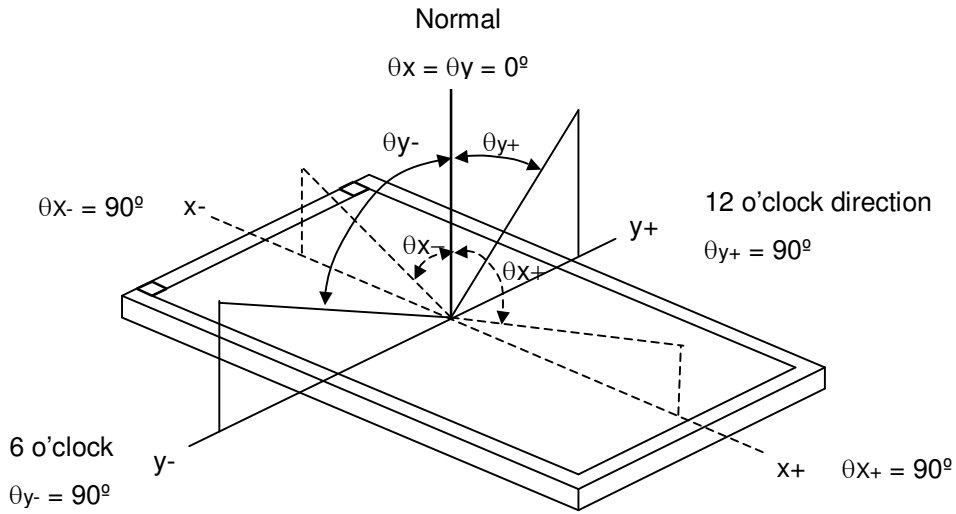

Note (2) Definition of Contrast Ratio (CR):

The contrast ratio can be calculated by the following expression.

$$\text{Contrast Ratio (CR)} = L_{255} / L_0$$

L255: Luminance of gray level 255

L 0: Luminance of gray level 0

$$\text{CR} = \text{CR} (1)$$

CR (X) is corresponding to the Contrast Ratio of the point X at Figure in Note (6).

Note (3) Definition of Response Time (T_R, T_F):

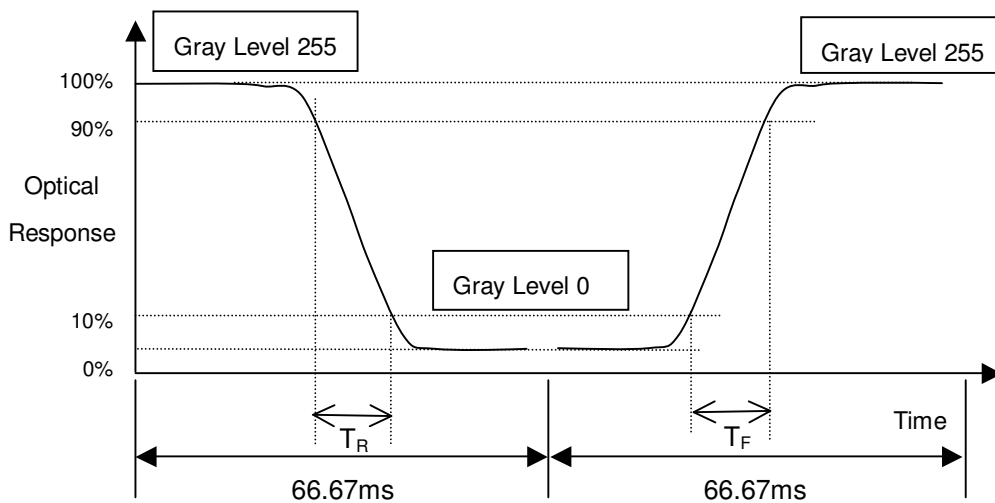

Note (4) Definition of Luminance of White (L_c):

Measure the luminance of gray level 255 at center point

$$L_c = L(1)$$

$L(x)$ is corresponding to the luminance of the point X at Figure in Note (6).

Note (5) Measurement Setup:

The LCD module should be stabilized at given temperature for 20 minutes to avoid abrupt temperature change during measuring. In order to stabilize the luminance, the measurement should be executed after lighting Backlight for 20 minutes in a windless room.

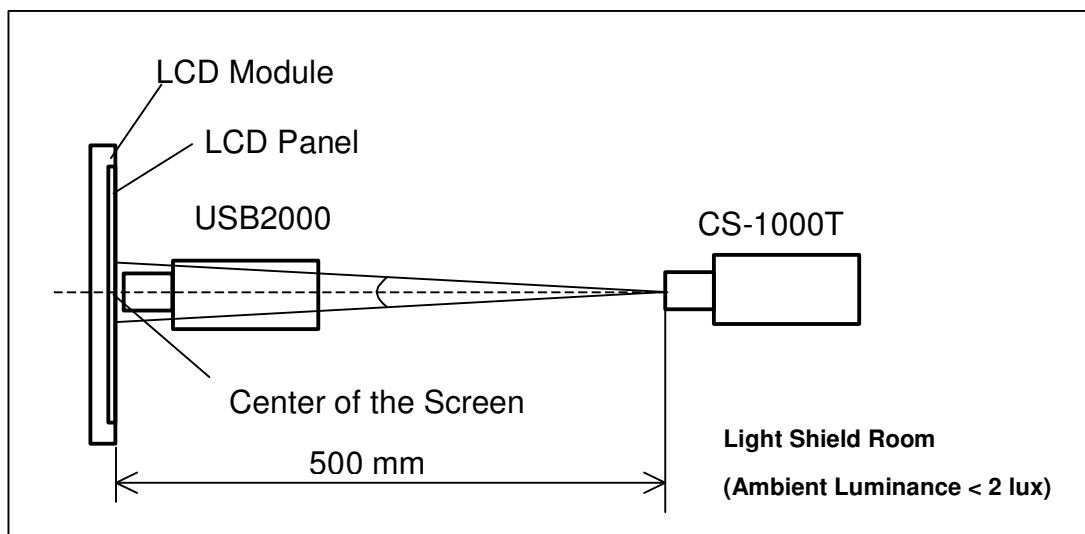

Note (6) Definition of White Variation (δW):

Measure the luminance of gray level 255 at 13 points

$$\delta W = \frac{\text{Maximum [L(1), L(2), L(3), L(4), L(5), L(6), L(7), L(8), L(9), L(10), L(11), L(12), L(13)]}}{\text{Minimum [L(1), L(2), L(3), L(4), L(5), L(6), L(7), L(8), L(9), L(10), L(11), L(12), L(13)]}}$$

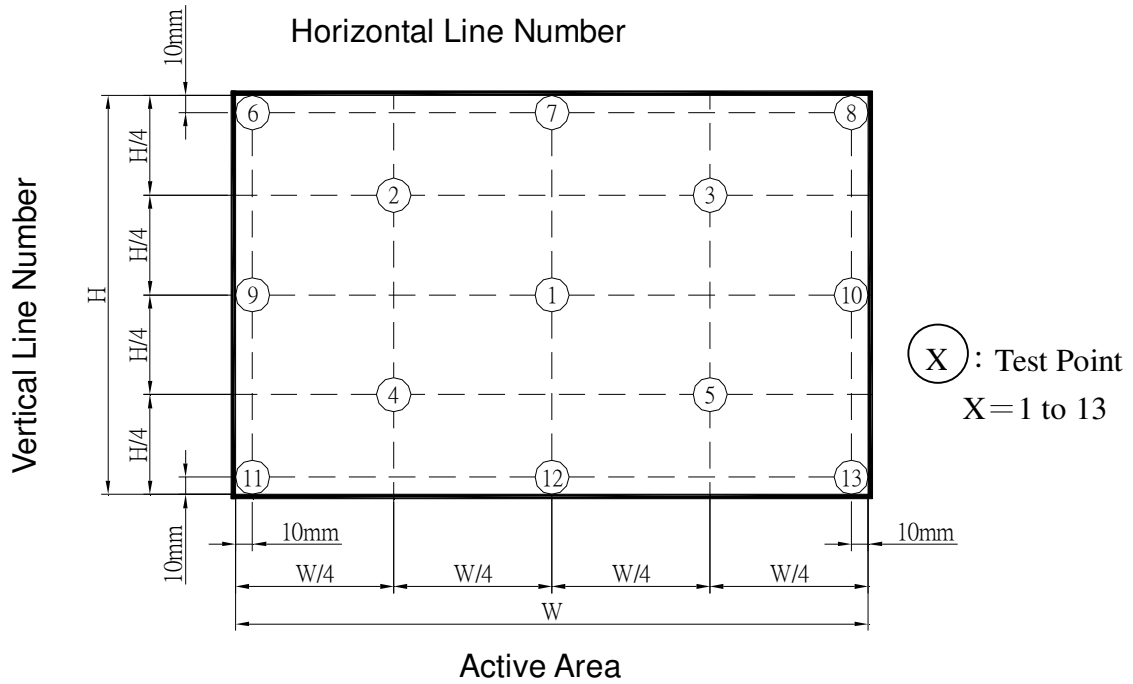

Note (7) Definition of Response Time (T_{GTG_AVE}):

T_{GTG_AVE} is defined as the total average response time for "Gray To Gray".

The Gray to Gray response time is defined as the following chart.

Gray to Gray		Target Gray								
		G0	G32	G64	G96	G128	G160	G192	G224	G255
Initial Gray	G0									
	G32									
	G64									
	G96									
	G128									
	G160									
	G192									
	G224									
	G255									

8. PACKAGING :

8.1 PACKING SPECIFICATIONS

- (1) 10 LCD modules / 1 Box
- (2) Box dimensions: 489(L) X 382(W) X 330(H) mm
- (3) Weight: approximately 15.7Kg (10 modules per box)

8.2 PACKING METHOD

- (1) Carton Packing should have no failure in the following reliability test items.

Test Item	Test Conditions	Note
Vibration	ISTA STANDARD Random, Frequency Range: 1 – 200 Hz Top & Bottom: 30 minutes (+Z), 10 min (-Z), Right & Left: 10 minutes (X) Back & Forth 10 minutes (Y)	Non Operation
Dropping Test	1 Angle, 3 Edge, 6 Face, 60cm	Non Operation

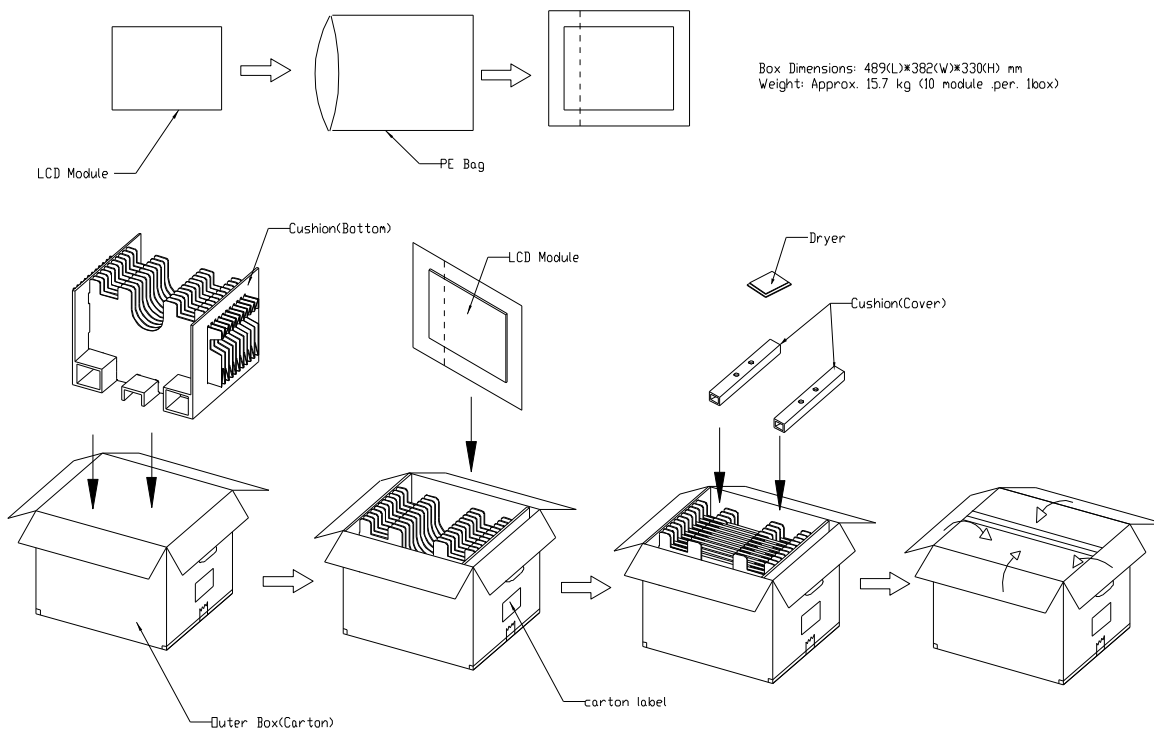

Figure. 8-1 Packing method

Sea and land transportation

Sea and land transportation

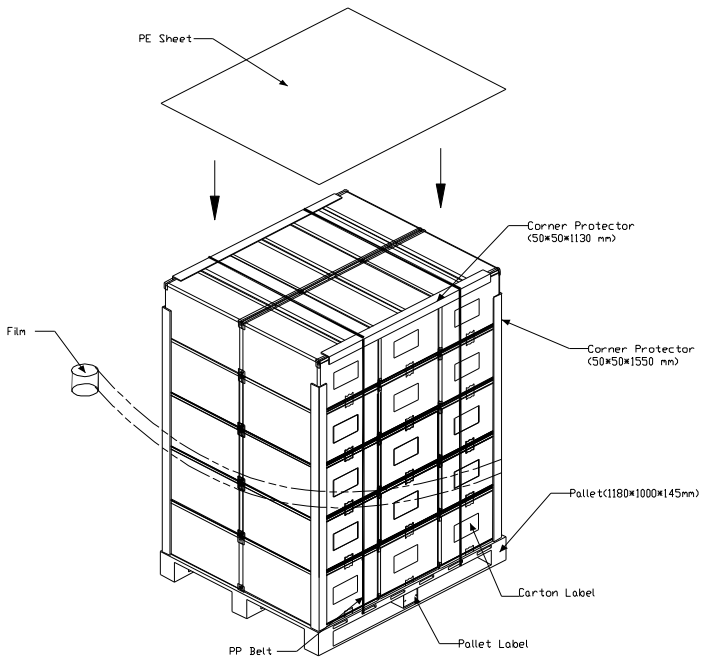

Figure. 8-2 Packing method

Air transportation

Air transportation

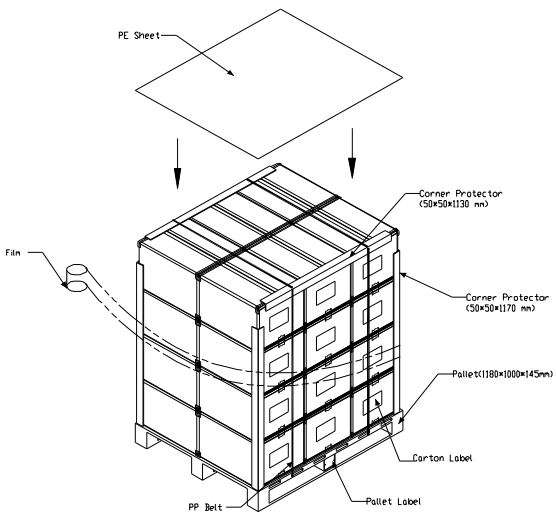

Figure. 8-3 Packing method

9. DEFINITION OF LABELS

9.1 CMO MODULE LABEL

The barcode nameplate is pasted on each module as illustration, and its definitions are as following explanation.



- (a) Model Name: M156B1-L01
- (b) Revision: Rev. XX, for example: A0, A1... B1, B2... or C1, C2...etc.
- (c) CMO barcode definition:

Serial ID: XX-XX-X-XX-YMD-L-NNNN

Code	Meaning	Description
XX	CMO internal use	-
XX	Revision	Cover all the change
X	CMO internal use	-
XX	CMO internal use	-
YMD	Year, month, day	Year: 2001=1, 2002=2, 2003=3, 2004=4... Month: 1~12=1, 2, 3, ~, 9, A, B, C Day: 1~31=1, 2, 3, ~, 9, A, B, C, ~, W, X, Y, exclude I, O, and U.
L	Product line #	Line 1=1, Line 2=2, Line 3=3, ...
NNNN	Serial number	Manufacturing sequence of product

- (d) Customer's barcode definition:

Serial ID: CM-15B11-X-X-X-XX-L-XX-L-YMD-NNNN

Code	Meaning	Description
CM	Supplier code	CMO=CM
15B11	Model number	M156B1-L01 = 15B11
X	Revision code	Non ZBD: 1,~,9,0 / ZBD: A~Z
X	Source driver IC code	Century=1, CLL=2, Demos=3, Epson=4, Fujitsu=5, Himax=6, Hitachi=7, Hynix=8, LDI=9, Matsushita=A, NEC=B, Novatec=C, OKI=D, Philips=E, Renesas=F, Samsung=G, Sanyo=H, Sharp=I, TI=J, Topro=K, Toshiba=L, Windbond=M
X	Gate driver IC code	
XX	Cell location	Tainan Taiwan=TN, Ningbo China=NP
L	Cell line #	1~12=0~C
XX	Module location	Tainan Taiwan=TN, Ningbo China=NP
L	Module line #	1~12=0~C
YMD	Year, month, day	Year: 2001=1, 2002=2, 2003=3, 2004=4... Month: 1~12=1, 2, 3, ~, 9, A, B, C Day: 1~31=1, 2, 3, ~, 9, A, B, C, ~, T, U, V
NNNN	Serial number	By LCD supplier

10. PRECAUTIONS

10.1 ASSEMBLY AND HANDLING PRECAUTIONS

- (1) Do not apply rough force such as bending or twisting to the module during assembly.
- (2) To assemble or install module into user's system can be only in clean working areas. The dust and oil may cause electrical short or worsen the polarizer.
- (3) It's not permitted to have pressure or impulse on the module because the LCD panel and Backlight will be damaged.
- (4) Always follow the correct power sequence when LCD module is connecting and operating. This can prevent damage to the CMOS LSI chips during latch-up.
- (5) Do not pull the I/F connector in or out while the module is operating.
- (6) Do not disassemble the module.
- (7) Use a soft dry cloth without chemicals for cleaning, because the surface of polarizer is very soft and easily scratched.
- (8) It is dangerous that moisture come into or contacted the LCD module, because moisture may damage LCD module when it is operating.
- (9) High temperature or humidity may reduce the performance of module. Please store LCD module within the specified storage conditions.
- (10) When ambient temperature is lower than 10°C may reduce the display quality. For example, the response time will become slowly, and the starting voltage of CCFL will be higher than room temperature.

10.2 SAFETY PRECAUTIONS

- (1) The startup voltage of Backlight is approximately 1000 Volts. It may cause electrical shock while assembling with inverter. Do not disassemble the module or insert anything into the Backlight unit.
- (2) If the liquid crystal material leaks from the panel, it should be kept away from the eyes or mouth. In case of contact with hands, skin or clothes, it has to be washed away thoroughly with soap.
- (3) After the module's end of life, it is not harmful in case of normal operation and storage.

