



## TFT LCD Approval Specification

# MODEL NO.: M170E5-L09

Customer : \_\_\_\_\_

Approved by : \_\_\_\_\_

Note :

Liquid Crystal Display Division	
QRA Division.	OA Head Division.
Approval	Approval
	

- CONTENTS -

REVISION HISTORY	-----	3
1. GENERAL DESCRIPTION	-----	4
1.1 OVERVIEW		
1.2 FEATURES		
1.3 APPLICATION		
1.4 GENERAL SPECIFICATIONS		
1.5 MECHANICAL SPECIFICATIONS		
2. ABSOLUTE MAXIMUM RATINGS	-----	5
2.1 ABSOLUTE RATINGS OF ENVIRONMENT		
2.2 ELECTRICAL ABSOLUTE RATINGS		
2.2.1 TFT LCD MODULE		
2.2.2 BACKLIGHT UNIT		
3. ELECTRICAL CHARACTERISTICS	-----	7
3.1 TFT LCD MODULE		
3.2 BACKLIGHT UNIT		
4. BLOCK DIAGRAM	-----	11
4.1 TFT LCD MODULE		
4.2 BACKLIGHT UNIT		
5. INPUT TERMINAL PIN ASSIGNMENT	-----	12
5.1 TFT LCD MODULE		
5.2 BACKLIGHT UNIT		
5.3 TIMING DIAGRAM OF LVDS INPUT SIGNAL		
5.4 COLOR DATA INPUT ASSIGNMENT		
6. INTERFACE TIMING	-----	15
6.1 INPUT SIGNAL TIMING SPECIFICATIONS		
6.2 POWER ON/OFF SEQUENCE		
7. OPTICAL CHARACTERISTICS	-----	17
7.1 TEST CONDITIONS		
7.2 OPTICAL SPECIFICATIONS		
8. PACKAGING	-----	23
8.1 PACKING SPECIFICATIONS		
8.2 PACKING METHOD		
9. DEFINITION OF LABELS	-----	25
10. PRECAUTIONS	-----	26
10.1 ASSEMBLY AND HANDLING PRECAUTIONS		
10.2 SAFETY PRECAUTIONS		
11. MECHANICAL CHARACTERISTICS	-----	27

**REVISION HISTORY**

Version	Date	Section	Description
Ver. 1.0	Nov, 10 '04	-	M170E5-L09 Specifications was first issued .
Ver. 2.0	Mar., 8 '05	6.2	Change T1 range from $0.0\text{ms} \leq T1 \leq 10\text{ms}$ to $0.5\text{ms} \leq T1 \leq 10\text{ms}$
		8.2	Change package method drawing
Ver. 2.1	Mar., 18 '05	7.2	To modify "Response time" value in "Optical specification table".
Ver. 2.2	Apr., 01 '05	3.2	To modify "Operating Frequency" value in "Lamp specification table".
		7.1	To modify "Inverter Driving Frequency" value in "Test Condition table".
		7.1	To modify "Inverter type" in "Test Condition table".
		7.2	To modify "By" value in "Optical specifications table".
		7.2	To modify description and drawing in "Note(3)".
		7.2	To modify description and drawing in "Note(6)".
Ver. 2.3	Apr., 14 '05	1.5	To modify "Weight" value in Mechanical specifications.
Ver. 2.4	Apr., 19 '05	6.2	To modify "T5" range from $450\text{ms} \leq T5$ to $200\text{ms} \leq T5$ in PowerOn/Off sequence!
Ver. 2.5	May, 11 '05	3.1	To delete the last row in "TFT LCD module" table.
		3.1	To modify "Power supply Current" value in "TFT LCD MODULE" table.
		4.1	To delete the "SELLVDS" word in "TFT LCD Module" sketch.
		5.1	To delete the 28 <sup>th</sup> row in "TFT LCD Module" 1 <sup>st</sup> table and the first row in 2 <sup>nd</sup> table.
		9.1	To modify label drawing and description method.

## 1. GENERAL DESCRIPTION

### 1.1 OVERVIEW

The M170E5-L09 model is a 17.0" TFT-LCD module with a 4-CCFL Backlight Unit and a 30-pin 2ch-LVDS interface. This module supports 1280 x 1024 SXGA mode and displays 16.2M colors. The inverter module for the Backlight Unit is not built in.

### 1.2 FEATURES

- Wide viewing angle
- High contrast ratio
- Fast response time
- High color saturation (EBU Like Specifications)
- SXGA (1280 x 1024 pixels) resolution
- DE (Data Enable) only mode
- LVDS (Low Voltage Differential Signaling) interface

### 1.3 APPLICATION

- TFT LCD Monitor

### 1.4 GENERAL SPECIFICATIONS

Item	Specification	Unit	Note
Active Area	337.92 (H) x 270.34 (V) (17.0" diagonal)	mm	(1)
Bezel Opening Area	341.9 (H) x 274.4 (V)	mm	
Driver Element	a-si TFT active matrix	-	-
Pixel Number	1280 x R.G.B. x 1024	pixel	-
Pixel Pitch	0.264 (H) x 0.264 (V)	mm	-
Pixel Arrangement	RGB vertical stripe	-	-
Display Colors	16.2M	color	-
Transmissive Mode	Normally white	-	-
Surface Treatment	Hard coating (3H), AG (Haze 25%)	-	-

### 1.5 MECHANICAL SPECIFICATIONS

Item	Min.	Typ.	Max.	Unit	Note	
Module Size	Horizontal(H)	358.0	358.5	359.0	mm	(1)
	Vertical(V)	296.0	296.5	297.0	mm	
	Depth(D)	-	17.0	17.5	mm	
Weight	-	2180	2200	g	-	
I/F connector mounting position	The mounting inclination of the connector makes the screen center within $\pm 0.5\text{mm}$ as the horizontal.				(2)	

Note (1) Please refer to the attached drawings for more information of front and back outline dimensions.

(2) Connector mounting position

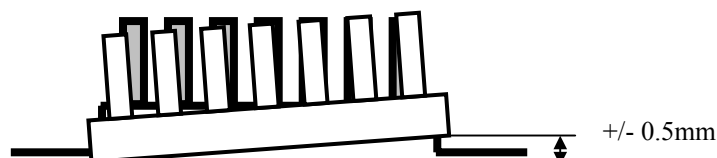

## 2. ABSOLUTE MAXIMUM RATINGS

### 2.1 ABSOLUTE RATINGS OF ENVIRONMENT

Item	Symbol	Value		Unit	Note
		Min.	Max.		
Storage Temperature	T <sub>ST</sub>	-20	+60	°C	(1)
Operating Ambient Temperature	T <sub>OP</sub>	0	+50	°C	(1), (2)
Shock (Non-Operating)	S <sub>NOP</sub>	-	50	G	(3), (5)
Vibration (Non-Operating)	V <sub>NOP</sub>	-	1.5	G	(4), (5)

Note (1) Temperature and relative humidity range is shown in the figure below.

(a) 90 %RH Max. (Ta ≤ 40 °C).

(b) Wet-bulb temperature should be 39 °C Max. (Ta > 40 °C).

(c) No condensation.

Note (2) The temperature of panel surface should be 0 °C Min. and 60 °C Max.

Note (3) 11ms, half-sine wave, 1 time for ± X, ± Y, ± Z.

Note (4) 10 ~ 300 Hz, sweep rate 10 min / cycle , 30 min for X,Y,Z axis

Note (5) Upon the Vibration and Shock tests, the fixture used to hold the module must be firm and rigid enough to prevent the module from twisting or bending by the fixture.

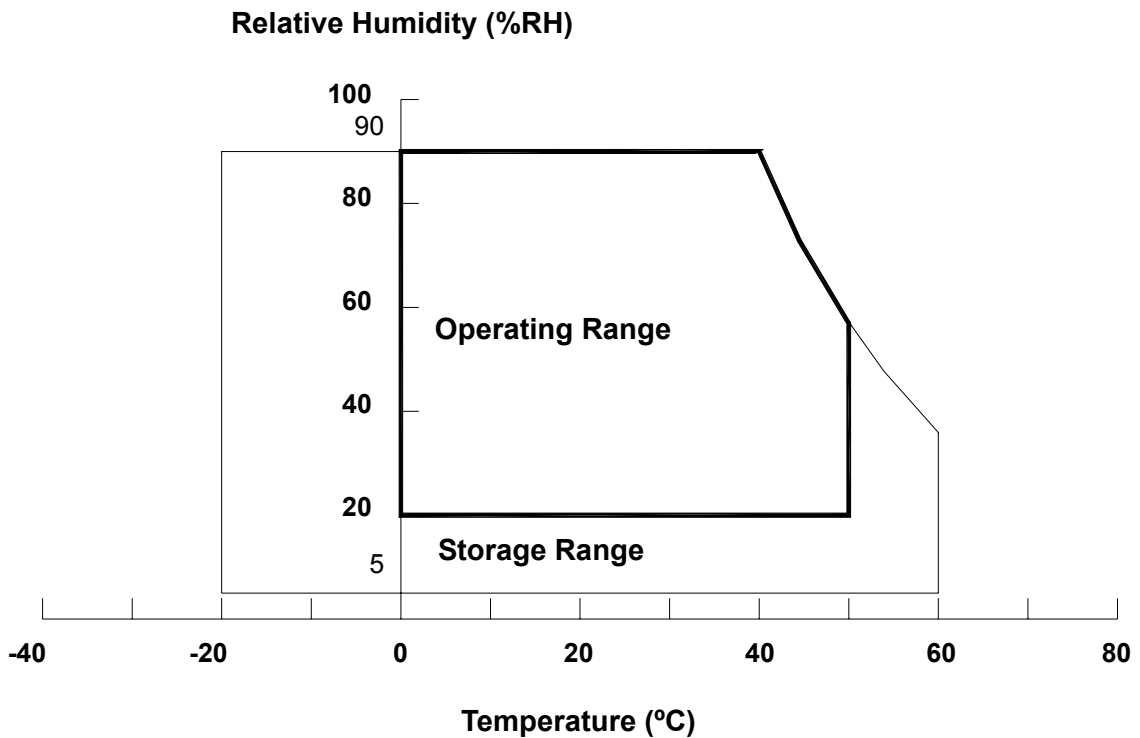

## 2.2 ELECTRICAL ABSOLUTE RATINGS

### 2.2.1 TFT LCD MODULE

Item	Symbol	Value		Unit	Note
		Min.	Max.		
Power Supply Voltage	V <sub>CC</sub>	-0.3	+6.0	V	(1)
Logic Input Voltage	V <sub>IN</sub>	-0.3	4.3	V	

### 2.2.2 BACKLIGHT UNIT

Item	Symbol	Value		Unit	Note
		Min.	Max.		
Lamp Voltage	V <sub>L</sub>	-	2.5K	V <sub>RMS</sub>	(1), (2), I <sub>L</sub> = 6.5 mA
Lamp Current	I <sub>L</sub>	-	7.5	mA <sub>RMS</sub>	
Lamp Frequency	F <sub>L</sub>	-	80	KHZ	(1), (2)

Note (1) Permanent damage might occur if the module is operated at conditions exceeding the maximum values.

Note (2) Specified values are for lamp (Refer to 3.2 for further information).

### 3. ELECTRICAL CHARACTERISTICS

#### 3.1 TFT LCD MODULE

Ta = 25 ± 2 °C

Parameter	Symbol	Value			Unit	Note
		Min.	Typ.	Max.		
Power Supply Voltage	Vcc	4.5	5.0	5.5	V	-
Ripple Voltage	V <sub>RP</sub>	-	--	100	mV	-
Rush Current	I <sub>RUSH</sub>	-	--	3.8	A	(2)
Power Supply Current	White	-	470	660	mA	(3)a
	Black	-	810	1130	mA	(3)b
	f <sub>V</sub> = 75Hz, Vcc=4.5V	-	-	1400	mA	(4)
LVDS differential input voltage	V <sub>id</sub>	-100	-	+100	mV	
LVDS common input voltage	V <sub>ic</sub>	--	1.2	--	V	

Note (1) The module is recommended to operate within specification ranges listed above for normal function.

Note (2) Measurement Conditions:

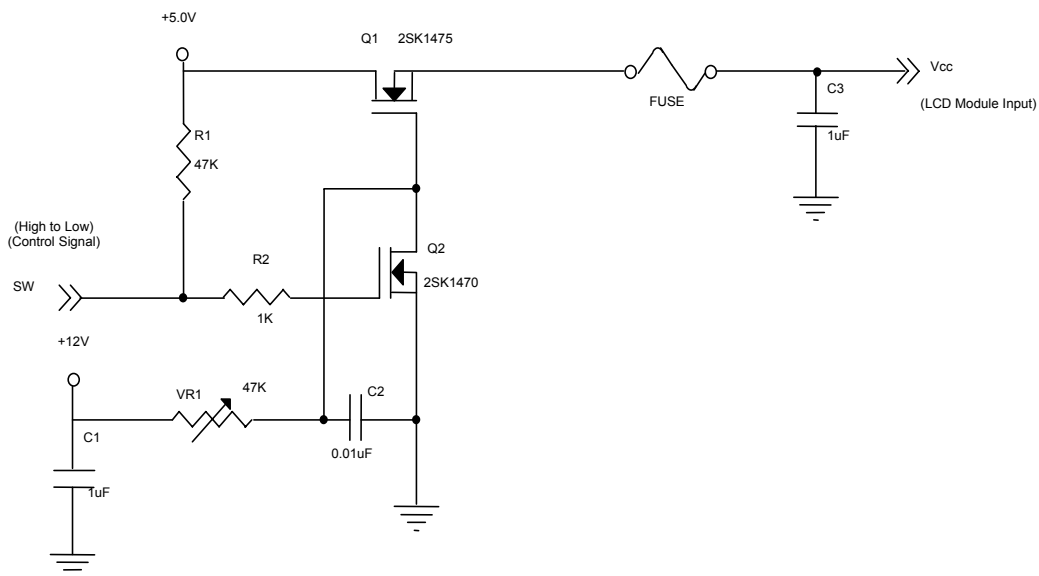

**Vcc rising time is 470μs**

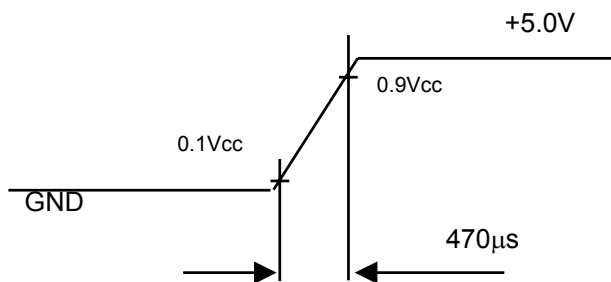

Note (3) The specified power supply current is under the conditions at  $V_{cc} = 5.0\text{ V}$ ,  $T_a = 25 \pm 2\text{ }^\circ\text{C}$ ,  $f_v = 60\text{ Hz}$ , whereas a power dissipation check pattern below is displayed.

a. White Pattern



Active Area

b. Black Pattern



Active Area

Note (4) The specified power supply current is under the conditions at  $V_{cc} = 4.5\text{ V}$ ,  $T_a = 25 \pm 2\text{ }^\circ\text{C}$ ,  $f_v = 75\text{ Hz}$ , whereas a power dissipation check pattern (Black Pattern) below is displayed.

Black Pattern

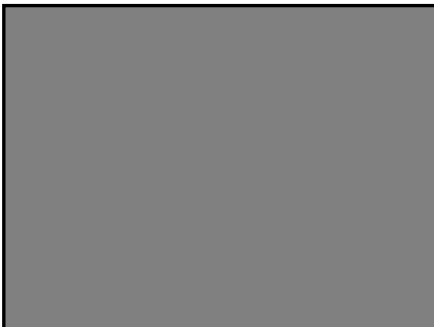

Active Area



### 3.2 BACKLIGHT UNIT

Parameter	Symbol	Value			Unit	Note
		Min.	Typ.	Max.		
Lamp Input Voltage	$V_L$	585	650	715	$V_{RMS}$	$I_L = 6.5 \text{ mA}$
Lamp Current	$I_L$	2.0	6.5	7.0	$\text{mA}_{RMS}$	(1)
Lamp Turn On Voltage	$V_S$	-	-	1260(25 °C)	$V_{RMS}$	(2)
		-	-	1500 (0 °C)	$V_{RMS}$	(2)
Operating Frequency	$F_L$	40	60	80	KHz	(3)
Lamp Life Time	$L_{BL}$	40,000	50,000	-	Hrs	(5) $I_L = 6.5 \text{ mA}$
Power Consumption	$P_L$	-	16.9	-	W	(4), $I_L = 6.5 \text{ mA}$

Note (1) Lamp current is measured by utilizing high-frequency current meters as shown below:

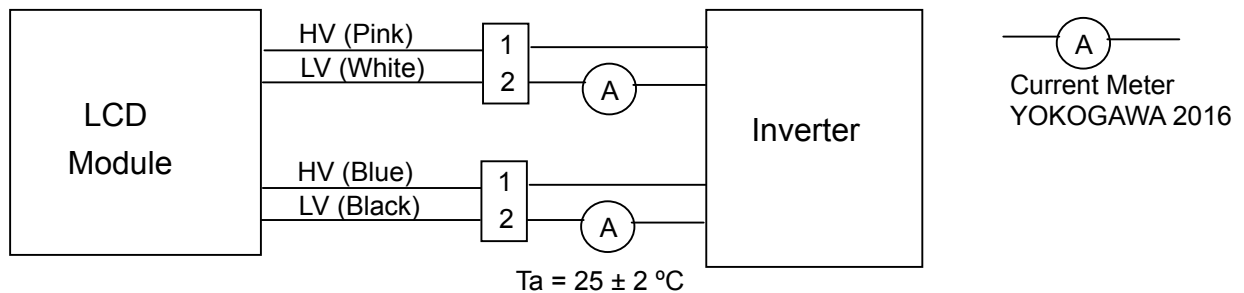

Note (2) The voltage shown above should be applied to the lamp for more than 1 second after startup. Otherwise, the lamp may not be turned on normally.

Note (3) The lamp frequency may produce interference with horizontal synchronization frequency from the display, which might cause line flow on the display. In order to avoid interference, the lamp frequency should be detached from the horizontal synchronization frequency and its harmonics as far as possible.

Note (4)  $P_L = I_L \times V_L$

Note (5) The lifetime of lamp can be defined as the time in which it continues to operate under the condition  $T_a = 25 \pm 2 \text{ }^\circ\text{C}$  and  $I_L = 2.0 \sim 6.5 \text{ mA}_{RMS}$  until one of the following events occurs:

- (a) When the brightness becomes or lower than 50% of its original value.
- (b) When the effective ignition length becomes or lowers than 80% of its original value. (Effective ignition length is defined as an area that has less than 70% brightness compared to the brightness in the center point.)

Note (6) The waveform of the voltage output of inverter must be area-symmetric and the design of the inverter must have specifications for the modularized lamp. The performance of the Backlight, such as lifetime or brightness, is greatly influenced by the characteristics of the DC-AC inverter for the lamp. All the parameters of an inverter should be carefully designed to avoid producing too much current leakage from high voltage output of the inverter. When designing or ordering the inverter please make sure that a poor lighting caused by the mismatch of the Backlight and the inverter (miss-lighting, flicker, etc.) never occurs. If the above situation is confirmed, the module should be operated in the same manners when it is installed in your instrument.

The output of the inverter must have symmetrical (negative and positive) voltage waveform and symmetrical current waveform. (Unsymmetrical ratio is less than 10%) Please do not use the inverter which has unsymmetrical voltage and unsymmetrical current and spike wave. Lamp frequency may produce interface with horizontal synchronous frequency and as a result this may cause beat on the display. Therefore lamp frequency shall be as away possible from the horizontal synchronous frequency and from its harmonics in order to prevent interference.

Requirements for a system inverter design, which is intended to have a better display performance, a better power efficiency and a more reliable lamp. It shall help increase the lamp lifetime and reduce its leakage current.

- a. The asymmetry rate of the inverter waveform should be 10% below;
- b. The distortion rate of the waveform should be within  $\sqrt{2} \pm 10\%$ ;
- c. The ideal sine wave form shall be symmetric in positive and negative polarities.

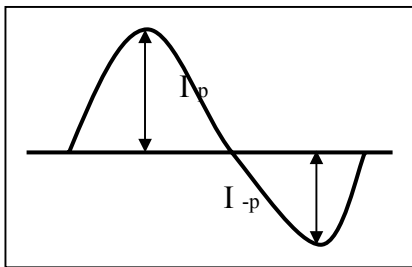

\* Asymmetry rate:

$$| I_p - I_{-p} | / I_{rms} * 100\%$$

\* Distortion rate

$$I_p \text{ (or } I_{-p}) / I_{rms}$$

## 4. BLOCK DIAGRAM

### 4.1 TFT LCD MODULE

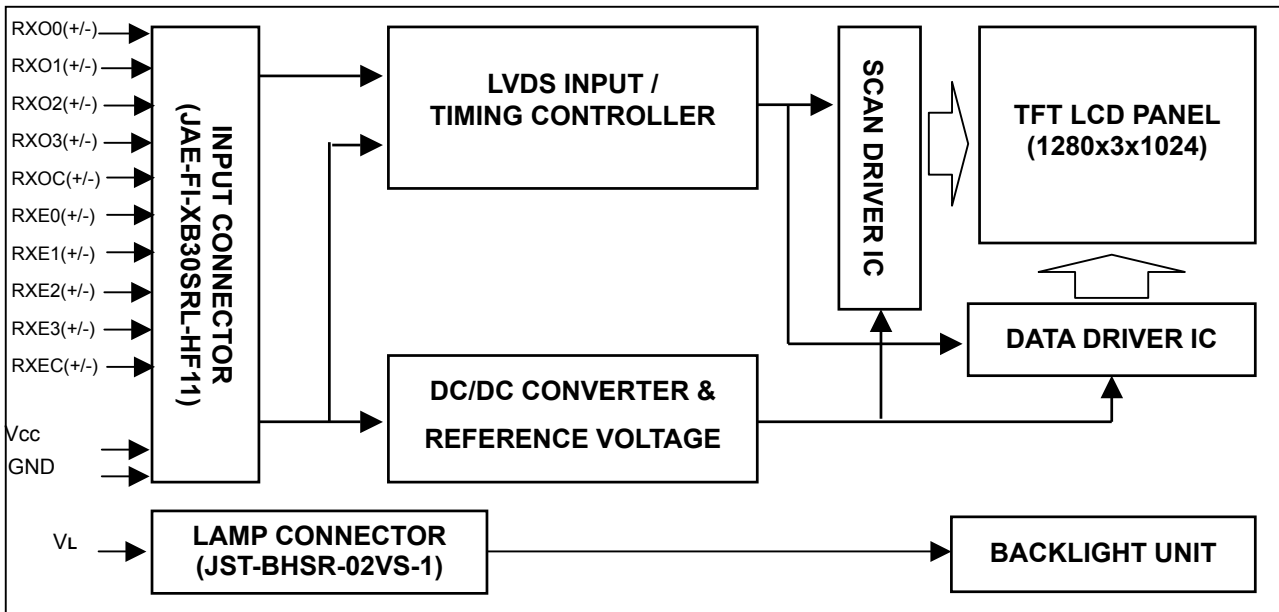

### 4.2 BACKLIGHT UNIT

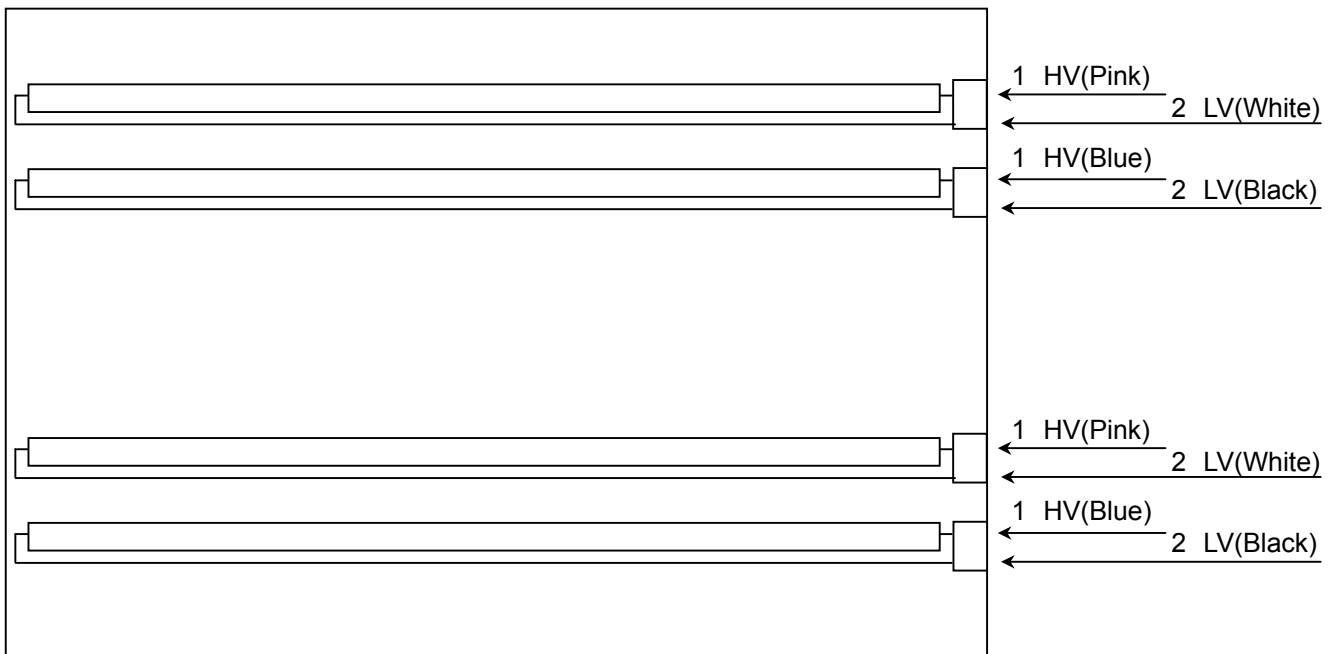

## 5. INPUT TERMINAL PIN ASSIGNMENT

### 5.1 TFT LCD MODULE

Pin	Name	Description
1	RXO0-	Negative LVDS differential data input. Channel O0 (odd)
2	RXO0+	Positive LVDS differential data input. Channel O0 (odd)
3	RXO1-	Negative LVDS differential data input. Channel O1 (odd)
4	RXO1+	Positive LVDS differential data input. Channel O1 (odd)
5	RXO2-	Negative LVDS differential data input. Channel O2 (odd)
6	RXO2+	Positive LVDS differential data input. Channel O2 (odd)
7	GND	Ground
8	RXOC-	Negative LVDS differential clock input. (odd)
9	RXOC+	Positive LVDS differential clock input. (odd)
10	RXO3-	Negative LVDS differential data input. Channel O3(odd)
11	RXO3+	Positive LVDS differential data input. Channel O3 (odd)
12	RXE0-	Negative LVDS differential data input. Channel E0 (even)
13	RXE0+	Positive LVDS differential data input. Channel E0 (even)
14	GND	Ground
15	RXE1-	Negative LVDS differential data input. Channel E1 (even)
16	RXE1+	Positive LVDS differential data input. Channel E1 (even)
17	GND	Ground
18	RXE2-	Negative LVDS differential data input. Channel E2 (even)
19	RXE2+	Positive LVDS differential data input. Channel E2 (even)
20	RXEC-	Negative LVDS differential clock input. (even)
21	RXEC+	Positive LVDS differential clock input. (even)
22	RXE3-	Negative LVDS differential data input. Channel E3 (even)
23	RXE3+	Positive LVDS differential data input. Channel E3 (even)
24	GND	Ground
25	TEST	Test pin should be tied to ground.
26	NC	Not connection.
28	VCC	+5.0V power supply
29	VCC	+5.0V power supply
30	VCC	+5.0V power supply

Note (1) Connector Part No.: FI-XB30SRL-HF11 (JAE).

Note (2) Mating Connector Part No.: FI-X30H; FI-X30C\*; FI-X30M\*; FI-X30HL (-T), FI-X30C\*L (-T) [JAE]

Note (3) The first pixel is odd.

Note (4) Input signal of even and odd clock should be the same timing.

LVDS Channel E0	LVDS output	D7	D6	D4	D3	D2	D1	D0
	Data order	EG0	ER5	ER4	ER3	ER2	ER1	ER0
LVDS Channel E1	LVDS output	D18	D15	D14	D13	D12	D9	D8
	Data order	EB1	EB0	EG5	EG4	EG3	EG2	EG1
LVDS Channel E2	LVDS output	D26	D25	D24	D22	D21	D20	D19
	Data order	DE	NA	NA	EB5	EB4	EB3	EB2
LVDS Channel E3	LVDS output	D23	D17	D16	D11	D10	D5	D27
	Data order	NA	EB7	EB6	EG7	EG6	ER7	ER6
LVDS Channel O0	LVDS output	D7	D6	D4	D3	D2	D1	D0
	Data order	OG0	OR5	OR4	OR3	OR2	OR1	OR0
LVDS Channel O1	LVDS output	D18	D15	D14	D13	D12	D9	D8
	Data order	OB1	OB0	OG5	OG4	OG3	OG2	OG1
LVDS Channel O2	LVDS output	D26	D25	D24	D22	D21	D20	D19
	Data order	DE	NA	NA	OB5	OB4	OB3	OB2
LVDS Channel O3	LVDS output	D23	D17	D16	D11	D10	D5	D27
	Data order	NA	OB7	OB6	OG7	OG6	OR7	OR6

## 5.2 BACKLIGHT UNIT

Pin	Symbol	Description	Remark
1	HV	High Voltage	Pink
2	LV	Low Voltage	White
1	HV	High Voltage	Blue
2	LV	Low Voltage	Black

Note (1) Connector Part No.: JST-BHSR-02VS-1 or equivalent

Note (2) User's connector Part No.: JST-SM02B-BHSS-1-TB (JST) or equivalent

## 5.3 COLOR DATA INPUT ASSIGNMENT

The brightness of each primary color (red, green and blue) is based on the 8-bit gray scale data input for the color. The higher the binary input, the brighter the color. The table below provides the assignment of color versus data input.

Color		Data Signal																							
		Red								Green								Blue							
		R7	R6	R5	R4	R3	R2	R1	R0	G7	G6	G5	G4	G3	G2	G1	G0	B7	B6	B5	B4	B3	B2	B1	B0
Basic Colors	Black	0	0	0	0	0	0	0	0	0	0	0	0	0	0	0	0	0	0	0	0	0	0	0	0
	Red	1	1	1	1	1	1	1	1	0	0	0	0	0	0	0	0	0	0	0	0	0	0	0	0
	Green	0	0	0	0	0	0	0	0	1	1	1	1	1	1	1	1	0	0	0	0	0	0	0	0
	Blue	0	0	0	0	0	0	0	0	0	0	0	0	0	0	0	0	1	1	1	1	1	1	1	1
	Cyan	0	0	0	0	0	0	0	0	1	1	1	1	1	1	1	1	1	1	1	1	1	1	1	1
	Magenta	1	1	1	1	1	1	1	1	0	0	0	0	0	0	0	0	1	1	1	1	1	1	1	1
	Yellow	1	1	1	1	1	1	1	1	1	1	1	1	1	1	1	1	0	0	0	0	0	0	0	0
	White	1	1	1	1	1	1	1	1	1	1	1	1	1	1	1	1	1	1	1	1	1	1	1	1
Gray Scale Of Red	Red(0) / Dark	0	0	0	0	0	0	0	0	0	0	0	0	0	0	0	0	0	0	0	0	0	0	0	0
	Red(1)	0	0	0	0	0	0	0	1	0	0	0	0	0	0	0	0	0	0	0	0	0	0	0	0
	Red(2)	0	0	0	0	0	0	1	0	0	0	0	0	0	0	0	0	0	0	0	0	0	0	0	0
	⋮	⋮	⋮	⋮	⋮	⋮	⋮	⋮	⋮	⋮	⋮	⋮	⋮	⋮	⋮	⋮	⋮	⋮	⋮	⋮	⋮	⋮	⋮	⋮	⋮
	⋮	⋮	⋮	⋮	⋮	⋮	⋮	⋮	⋮	⋮	⋮	⋮	⋮	⋮	⋮	⋮	⋮	⋮	⋮	⋮	⋮	⋮	⋮	⋮	⋮
	Red(253)	1	1	1	1	1	1	0	1	0	0	0	0	0	0	0	0	0	0	0	0	0	0	0	0
	Red(254)	1	1	1	1	1	1	1	0	0	0	0	0	0	0	0	0	0	0	0	0	0	0	0	0
	Red(255)	1	1	1	1	1	1	1	1	0	0	0	0	0	0	0	0	0	0	0	0	0	0	0	0
Gray Scale Of Green	Green(0) / Dark	0	0	0	0	0	0	0	0	0	0	0	0	0	0	0	0	0	0	0	0	0	0	0	0
	Green(1)	0	0	0	0	0	0	0	0	0	0	0	0	0	0	1	0	0	0	0	0	0	0	0	0
	Green(2)	0	0	0	0	0	0	0	0	0	0	0	0	0	1	0	0	0	0	0	0	0	0	0	0
	⋮	⋮	⋮	⋮	⋮	⋮	⋮	⋮	⋮	⋮	⋮	⋮	⋮	⋮	⋮	⋮	⋮	⋮	⋮	⋮	⋮	⋮	⋮	⋮	⋮
	⋮	⋮	⋮	⋮	⋮	⋮	⋮	⋮	⋮	⋮	⋮	⋮	⋮	⋮	⋮	⋮	⋮	⋮	⋮	⋮	⋮	⋮	⋮	⋮	⋮
	Green(253)	0	0	0	0	0	0	0	1	1	1	1	1	1	1	0	1	0	0	0	0	0	0	0	0
	Green(254)	0	0	0	0	0	0	0	1	1	1	1	1	1	1	0	0	0	0	0	0	0	0	0	0
	Green(255)	0	0	0	0	0	0	0	1	1	1	1	1	1	1	1	1	0	0	0	0	0	0	0	0
Gray Scale Of Blue	Blue(0) / Dark	0	0	0	0	0	0	0	0	0	0	0	0	0	0	0	0	0	0	0	0	0	0	0	0
	Blue(1)	0	0	0	0	0	0	0	0	0	0	0	0	0	0	0	0	0	0	0	0	0	0	0	1
	Blue(2)	0	0	0	0	0	0	0	0	0	0	0	0	0	0	0	0	0	0	0	0	0	0	1	0
	⋮	⋮	⋮	⋮	⋮	⋮	⋮	⋮	⋮	⋮	⋮	⋮	⋮	⋮	⋮	⋮	⋮	⋮	⋮	⋮	⋮	⋮	⋮	⋮	⋮
	⋮	⋮	⋮	⋮	⋮	⋮	⋮	⋮	⋮	⋮	⋮	⋮	⋮	⋮	⋮	⋮	⋮	⋮	⋮	⋮	⋮	⋮	⋮	⋮	⋮
	Blue(253)	0	0	0	0	0	0	0	0	0	0	0	0	0	0	0	0	1	1	1	1	1	1	0	1
	Blue(254)	0	0	0	0	0	0	0	0	0	0	0	0	0	0	0	0	1	1	1	1	1	1	1	0
	Blue(255)	0	0	0	0	0	0	0	0	0	0	0	0	0	0	0	0	1	1	1	1	1	1	1	1

Note (1) 0: Low Level Voltage, 1: High Level Voltage

## 6. INTERFACE TIMING

### 6.1 INPUT SIGNAL TIMING SPECIFICATIONS

The input signal timing specifications are shown as the following table and timing diagram.

Signal	Item	Symbol	Min.	Typ.	Max.	Unit	Note
LVDS Clock	Frequency	Fc	-	54	67.5	MHz	-
	Period	Tc	14.8	18.5	-	ns	-
	High Time	Tch	-	4/7	-	Tc	-
	Low Time	Tcl	-	3/7	-	Tc	-
LVDS Data	Setup Time	Tlvs	600	-	-	ps	-
	Hold Time	Tlvh	600	-	-	ps	-
Vertical Active Display Term	Frame Rate	Fr	56	60	75	Hz	Tv=Tvd+Tvb
	Total	Tv	1034	1066	1274	Th	-
	Display	Tvd	1024	1024	1024	Th	-
	Blank	Tvb	Tv-Tvd	42	Tv-Tvd	Th	-
Horizontal Active Display Term	Total	Th	690	844	960	Tc	Th=Thd+Thb
	Display	Thd	640	640	640	Tc	-
	Blank	Thb	Th-Thd	204	Th-Thd	Tc	-

Note : (1) Because this module is operated by DE only mode, Hsync and Vsync input signals should be set to low logic level or ground. Otherwise, this module would operate abnormally.

### INPUT SIGNAL TIMING DIAGRAM

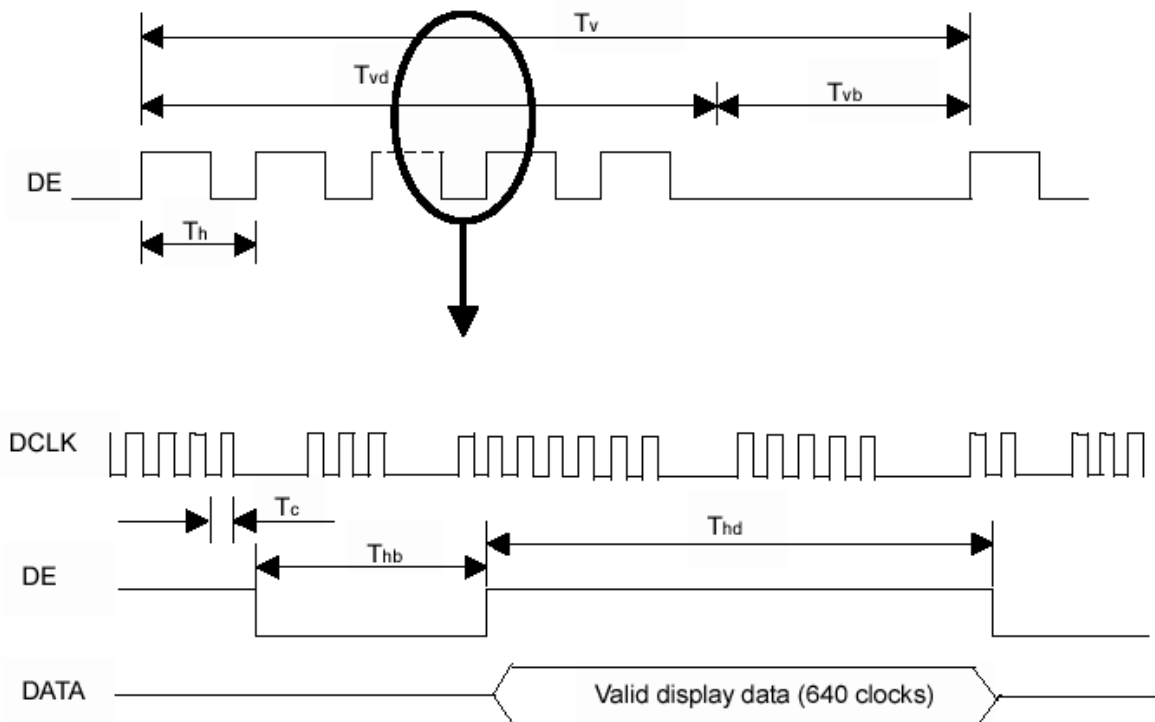

## 6.2 POWER ON/OFF SEQUENCE

To prevent a latch-up or DC operation of LCD module, the power on/off sequence should follow the conditions shown in the following diagram.

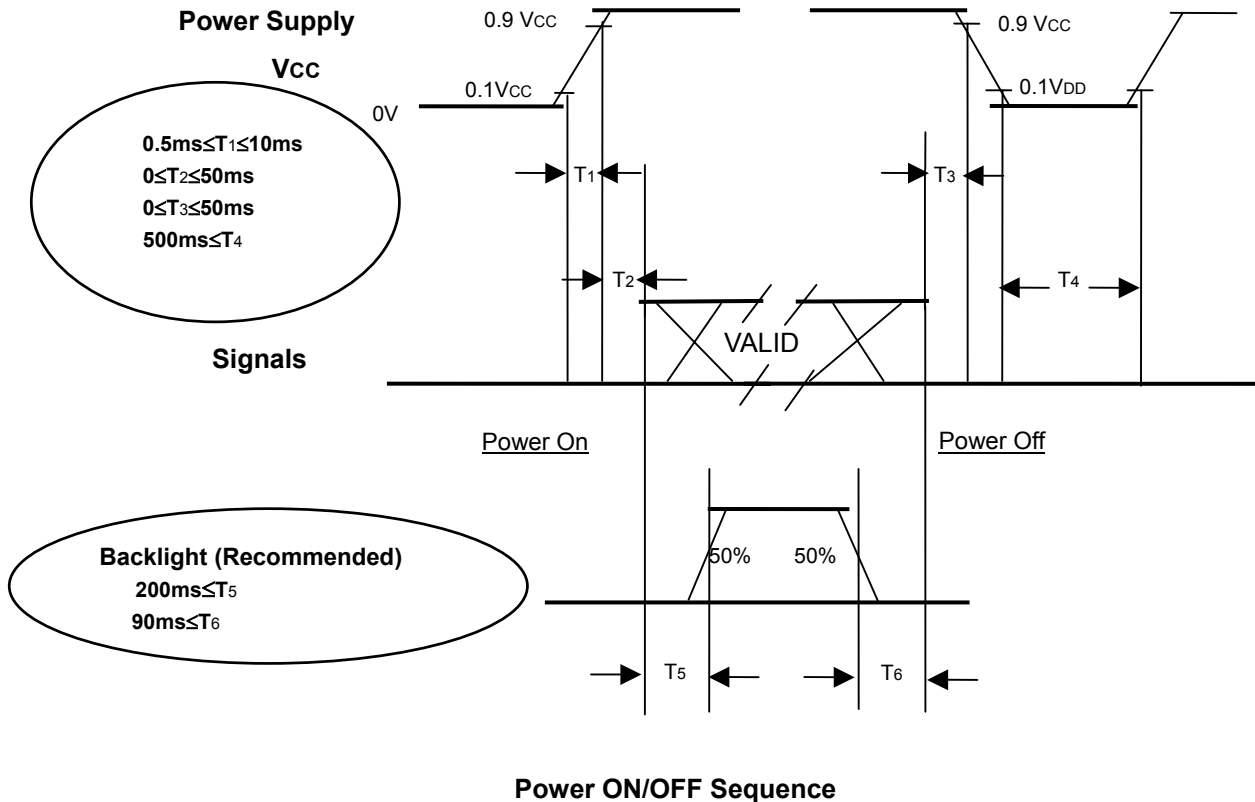

Note.

- (1) The supply voltage of the external system for the module input should be the same as the definition of V<sub>CC</sub>.
- (2) Please apply the lamp voltage within the LCD operation range. When the backlight turns on before the LCD operation of the LCD turns off, the display may, instantly, function abnormally.
- (3) In case of V<sub>CC</sub> = off level, please keep the level of input signals on the low or keep a high impedance.
- (4) T<sub>4</sub> should be measured after the module has been fully discharged between power on/off periods.
- (5) Interface signal shall not be kept at high impedance when the power is on.



## 7. OPTICAL CHARACTERISTICS

### 7.1 TEST CONDITIONS

Item	Symbol	Value	Unit
Ambient Temperature	Ta	25±2	°C
Ambient Humidity	Ha	50±10	%RH
Supply Voltage	V <sub>CC</sub>	5.0	V
Input Signal	According to typical value in "3. ELECTRICAL CHARACTERISTICS"		
Inverter Current	I <sub>L</sub>	6.5	mA
Inverter Driving Frequency	F <sub>L</sub>	60	KHz
Inverter	SUMIDA H05-5307		

### 7.2 OPTICAL SPECIFICATIONS

The relative measurement methods of optical characteristics are shown in 7.2. The following items should be measured under the test conditions described in 7.1 and stable environment shown in Note (6).

Item	Symbol	Condition	Min.	Typ.	Max.	Unit	Note					
Color Chromaticity	Red	$\theta_x=0^\circ, \theta_y=0^\circ$ CS-1000	Typ - 0.03	0.645	Typ + 0.03	-	(1), (6)					
				0.348		-						
	Green			0.280		-						
				0.605		-						
	Blue			0.142		-						
				0.069		-						
	White			0.313		-						
				0.329		-						
	Center Luminance of White			L <sub>C</sub>				230	300	---	cd/m <sup>2</sup>	(4), (6)
	Contrast Ratio			CR				400	500	---	-	(2), (6)
Response Time	T <sub>R</sub>	$\theta_x=0^\circ, \theta_y=0^\circ$	---	2	7	ms	(3)					
	T <sub>F</sub>			6	11	ms						
White Variation	$\delta W$	$\theta_x=0^\circ, \theta_y=0^\circ$	---	1.25	1.33	-	(6), (7)					
Cross Talk	CT	BM-5A	---	---	2.0	%	(5), (6)					
Viewing Angle	Horizontal	CR≥10 BM-5A	65	75	---	Deg.	(1), (6)					
				75	---							
	Vertical			60	70			---				
				50	60			---				
TCO'99 Luminance Uniformity (Angular-dependent)	L <sub>R</sub>	-	-	-	1.7	-	(8)					
TCO'99 Luminance Contrast (Angular-dependent)	C <sub>m</sub>	-	0.5	-	-	-	(9)					

Note (1) Definition of Viewing Angle ( $\theta_x, \theta_y$ ):

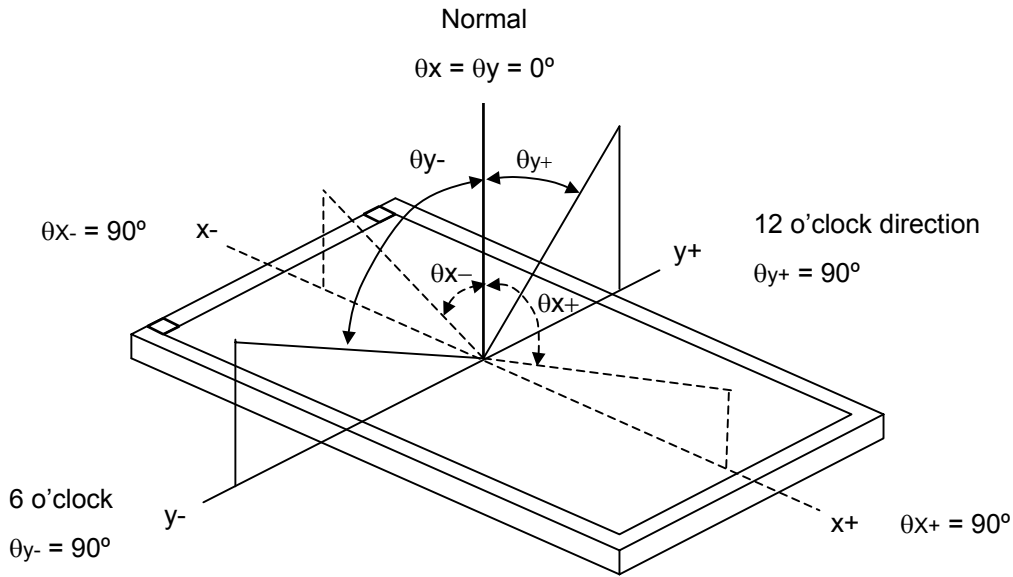

Note (2) Definition of Contrast Ratio (CR):

The contrast ratio can be calculated by the following expression.

$$\text{Contrast Ratio (CR)} = L_{255} / L_0$$

L255: Luminance of gray level 255

L 0: Luminance of gray level 0

$$\text{CR} = \text{CR} (5)$$

CR (X) is corresponding to the Contrast Ratio of the point X at Figure in Note (7).

Note (3) Definition of Response Time ( $T_R, T_F$ ) and measurement method:

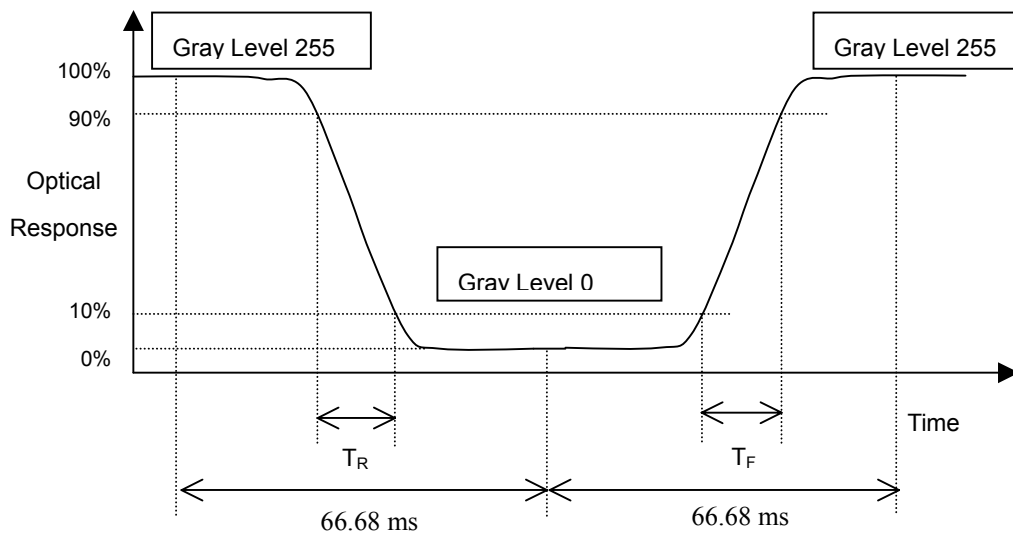

Note (4) Definition of Luminance of White ( $L_C$ ):

Measure the luminance of gray level 255 at center point

$$L_C = L(5)$$

$L(x)$  is corresponding to the luminance of the point X at Figure in Note (7).

Note (5) Definition of Cross Talk (CT):

$$CT = |Y_B - Y_A| / Y_A \times 100 (\%)$$

Where:

$Y_A$  = Luminance of measured location without gray level 0 pattern ( $cd/m^2$ )

$Y_B$  = Luminance of measured location with gray level 0 pattern ( $cd/m^2$ )

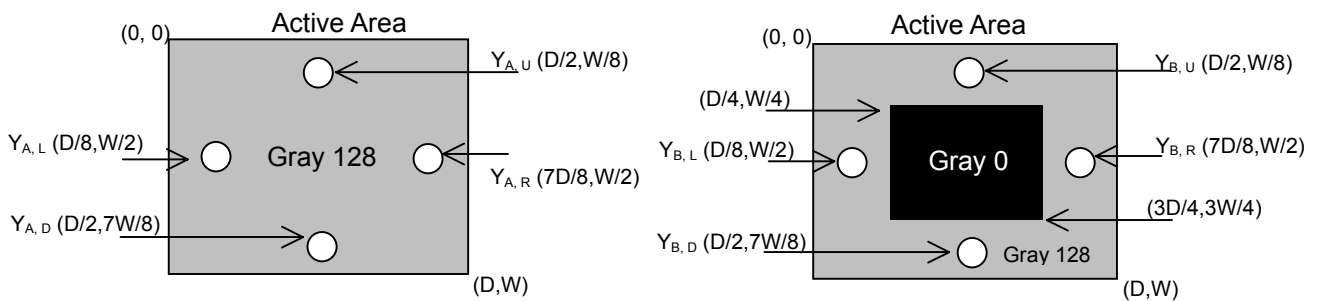

Note (6) Measurement Setup:

The LCD module should be stabilized at given temperature for 20 minutes to avoid abrupt temperature change during measuring. In order to stabilize the luminance, the measurement should be executed after lighting Backlight for 20 minutes in a windless room.

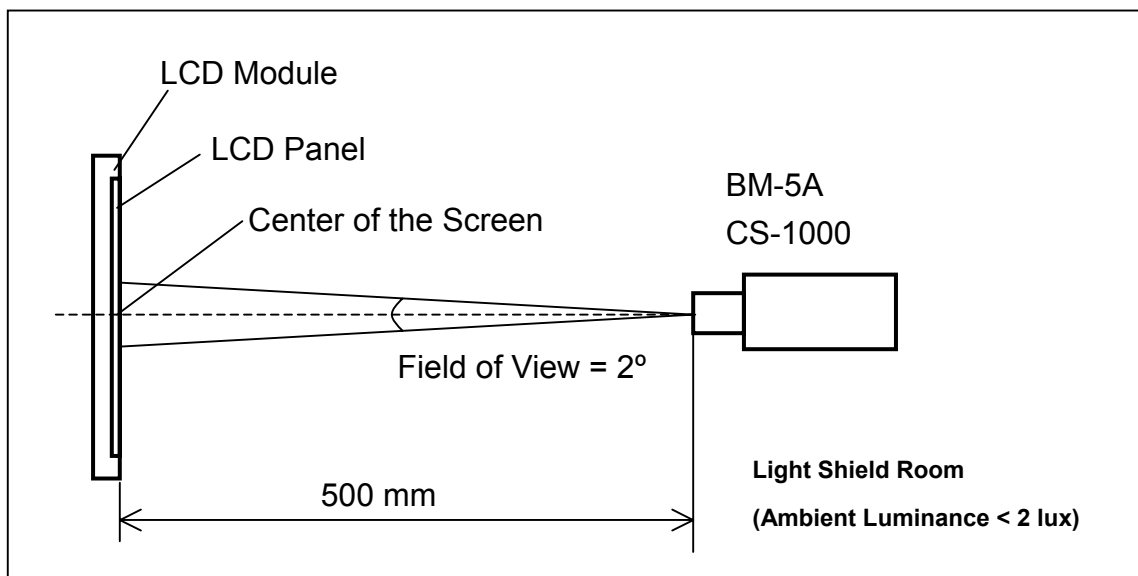

Note (7) Definition of White Variation ( $\delta W$ ):

Measure the luminance of gray level 255 at 9 points

$$\delta W = \frac{\text{Maximum [L (1), L (2), L (3), L (4), L (5), L (6), L (7), L (8), L (9)]}}{\text{Minimum [L (1), L (2), L (3), L (4), L (5), L (6), L (7), L (8), L (9)]}}$$

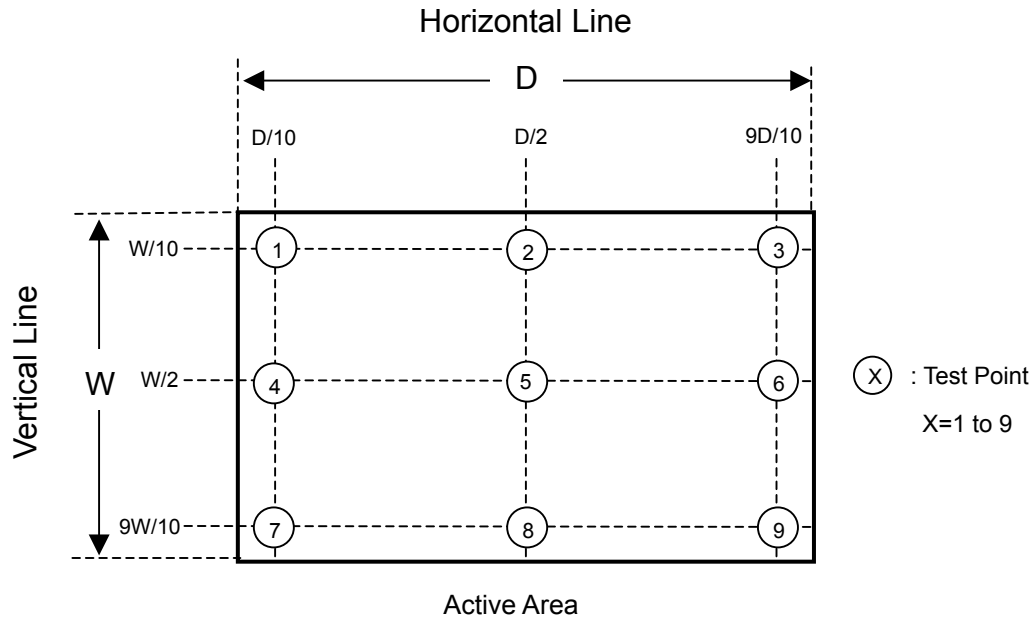

Note (8) Definition of TCO 99 Luminance Uniformity (Angular-dependent) (LR):

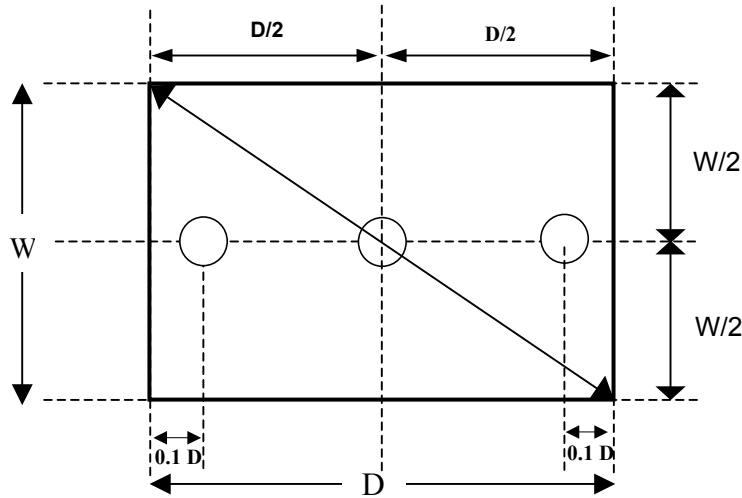

Luminance is measured at the center measurement position “C” on the LCD panel. The optical axis of the luminance meter shall be aligned with the normal of the panel surface. The measuring distance between the photometer and the surface of the panel is defined as:

$$Md \text{ (cm)} = \text{diagonal of the panel (cm)} \times 1.5 \quad \text{with minimum distance 50 cm.}$$

The panel is rotated around a vertical axis which passes the center of the display by changing the azimuthally angle to  $+30^\circ$ . The distance between the panel and the photometer remains unchanged and the measured point is exact the same as the previous measured point.

The photometer is then rotated by changing its azimuthally angle with the fixed distance to the panel. Luminance at points “L” and “R” are given:

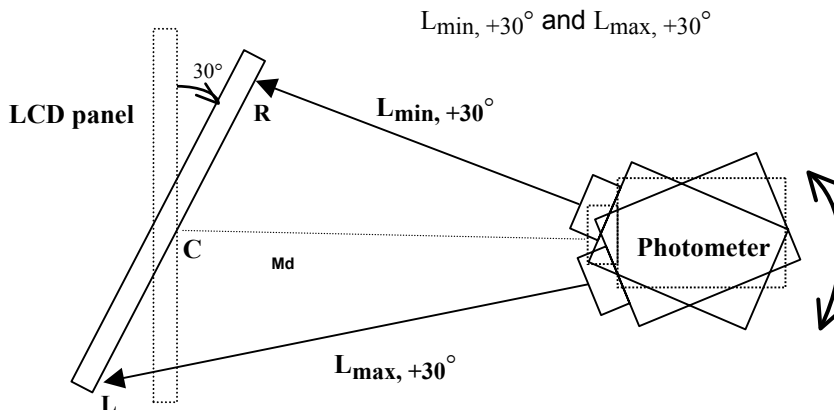

The LCD panel is then rotated to another azimuthally angle to  $-30^\circ$ ; and  $L_{\min, -30^\circ}$  and  $L_{\max, -30^\circ}$  are obtained by using the same procedure.

The Luminance Uniformity (LR) is calculated as follow:

$$LR = ((L_{\max, +30^\circ} / L_{\min, +30^\circ}) + (L_{\max, -30^\circ} / L_{\min, -30^\circ})) / 2.$$

Note (9) Definition of TCO 99 Luminance Contrast (Angular-dependent) (Cm):

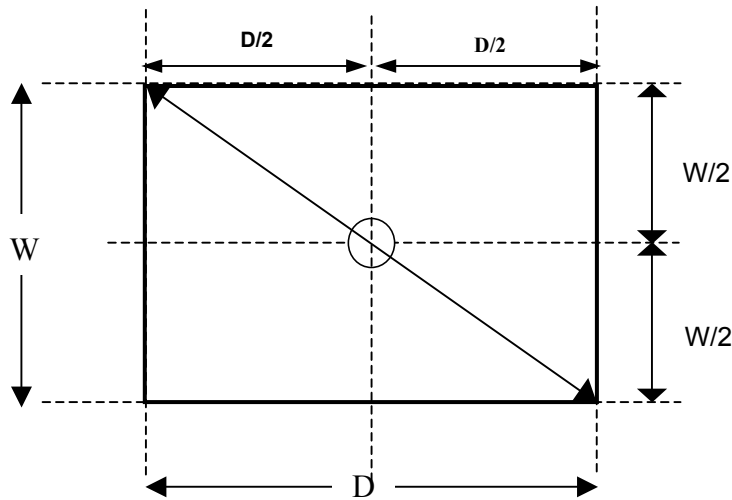

Luminance contrast is measured at the center point of the LCD panel "C" along with the normal of the display with the same distance described in Note 13. The display is then rotated around the vertical axis by changing its azimuthally axis to +30°; and this gives:

$$L_{255 \text{ G.L.}, +30^\circ} \text{ and } L_{0 \text{ G.L.}, +30^\circ}$$

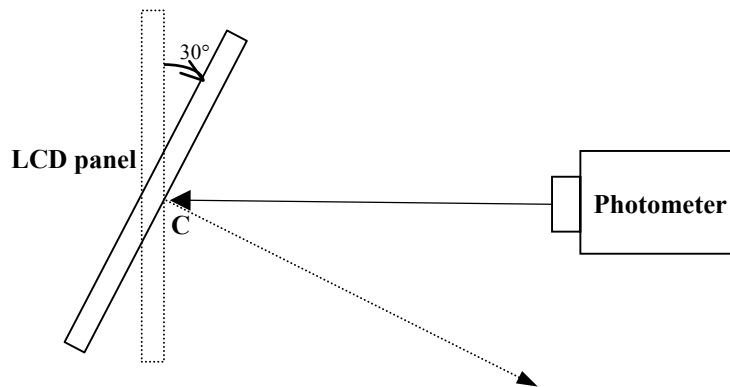

The LCD panel is then rotated to azimuthally angle to -30°; and  $L_{0 \text{ G.L.}, -30^\circ}$  and  $L_{255 \text{ G.L.}, -30^\circ}$  are obtained by using the same procedure. The Luminance Contrast (Cm) is calculated:

$$C_m = (L_{255 \text{ G.L.}} - L_{0 \text{ G.L.}}) / (L_{255 \text{ G.L.}} + L_{0 \text{ G.L.}})$$

For both +30° and -30°. The lower value for Cm is reported.

## 8. PACKAGING

### 8.1 PACKING SPECIFICATIONS

- (1) 5 LCD modules / 1 Box
- (2) Box dimensions: 537(L) X 316(W) X 462(H) mm
- (3) Weight: approximately 12Kg (5 modules per box)

### 8.2 PACKING METHOD

- (1) Carton Packing should have no failure in the following reliability test items.

Test Item	Test Conditions	Note
Vibration	ISTA STANDARD Random, Frequency Range: 1 – 200 Hz Top & Bottom: 30 minutes (+Z), 10 min (-Z), Right & Left: 10 minutes (X) Back & Forth 10 minutes (Y)	Non Operation
Dropping Test	1 Angle, 3 Edge, 6 Face, 60cm	Non Operation

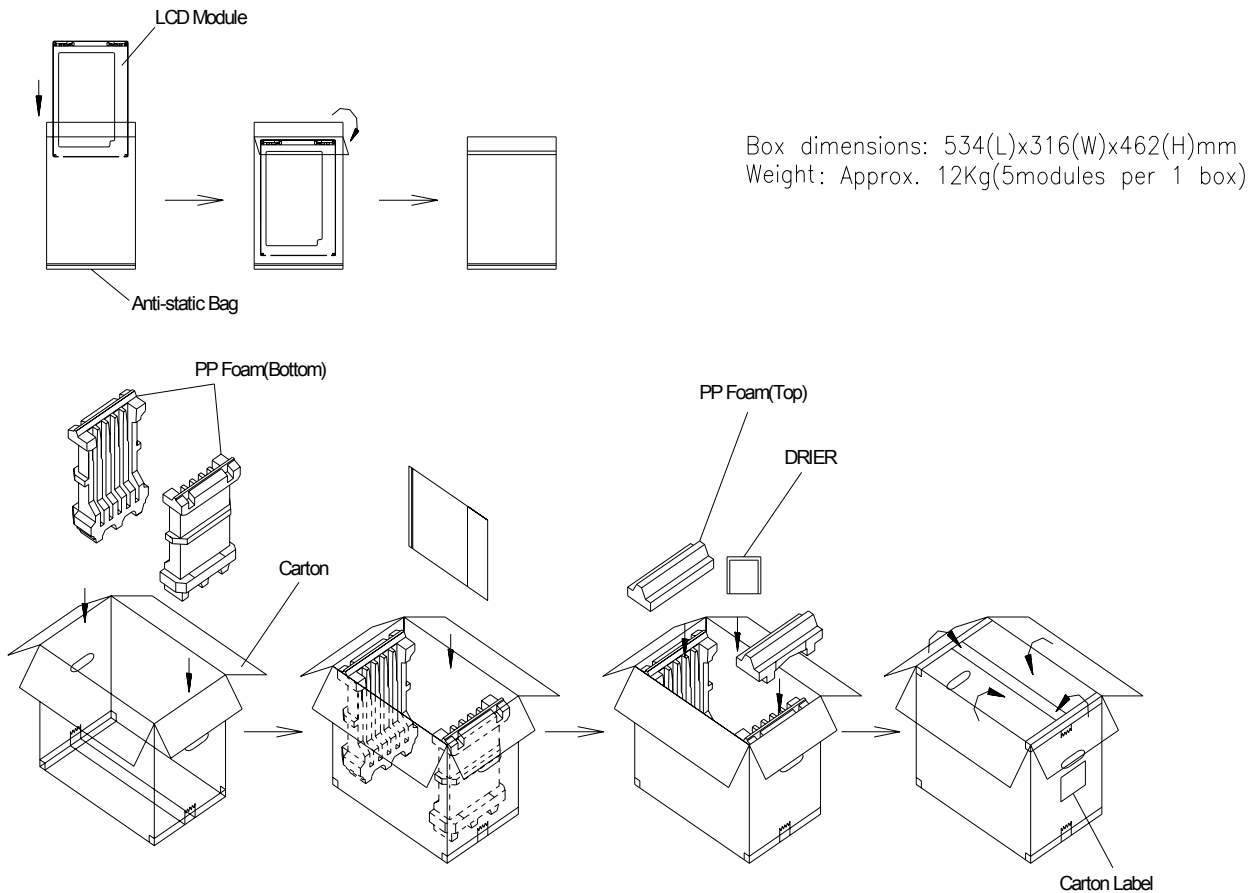

**Figure. 8-1 Packing method**

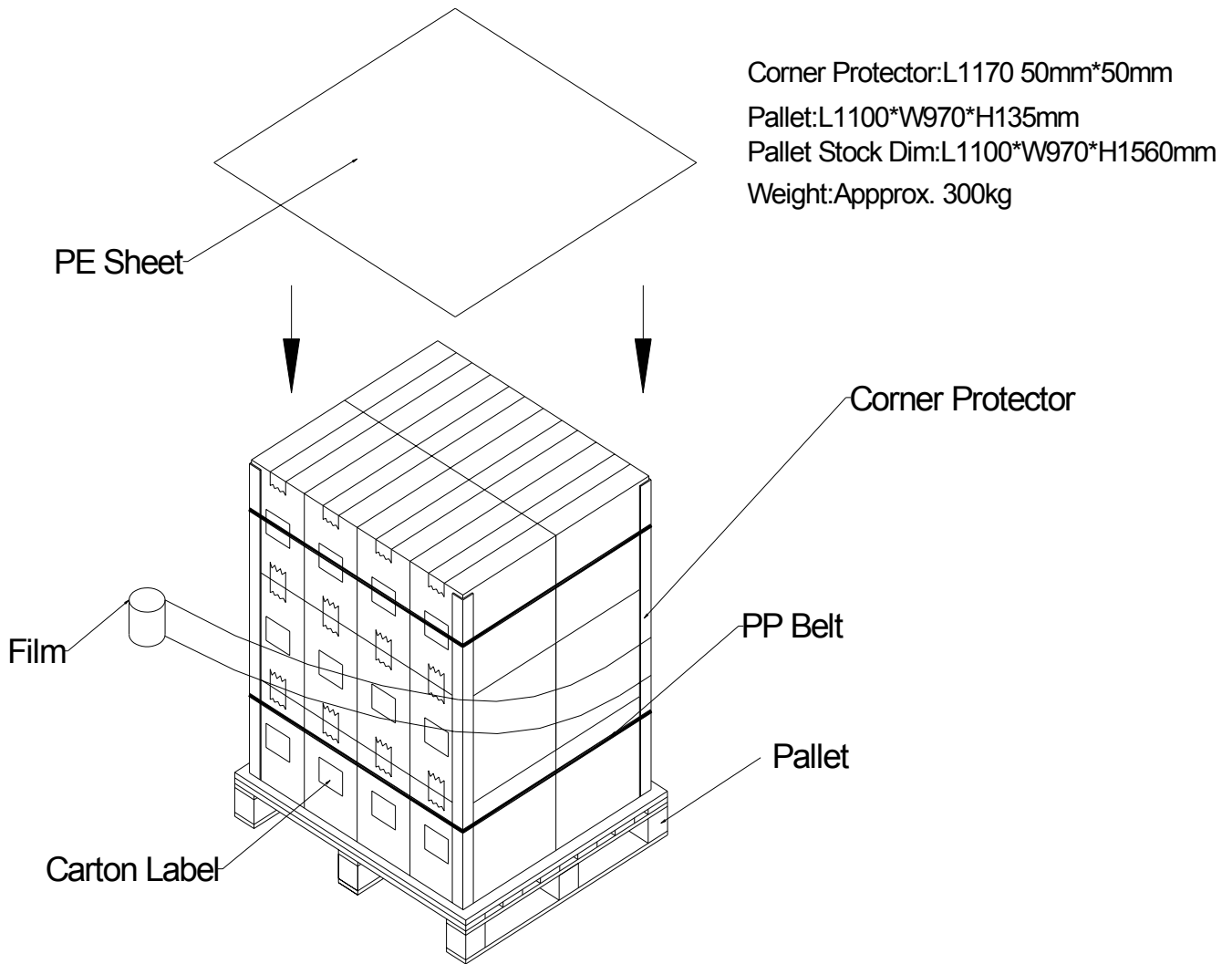

**Figure. 8-2 Packing method**



## 9. DEFINITION OF LABELS

### 9.1 CMO MODULE LABEL

The barcode nameplate is pasted on each module as illustration, and its definitions are as following explanation.



- (a) Model Name: M170E5-L09
- (b) Revision: Rev. XX, for example: A0, A1... B1, B2... or C1, C2...etc.
- (c) CMO barcode definition:

Serial ID: XX-XX-X-XX-YMD-L-NNNN

Code	Meaning	Description
XX	CMO internal use	-
XX	Revision	Cover all the change
X	CMO internal use	-
YMD	Year, month, day	Year: 2001=1, 2002=2, 2003=3, 2004=4... Month: 1~12=1, 2, 3, ~, 9, A, B, C Day: 1~31=1, 2, 3, ~, 9, A, B, C, ~, W, X, Y, exclude I, O, U.
L	Product line #	Line 1=1, Line 2=2, Line 3=3, ...etc.
NNNN	Serial number	Manufacturing sequence of product

## 10. PRECAUTIONS

### 10.1 ASSEMBLY AND HANDLING PRECAUTIONS

- (1) Do not apply rough force such as bending or twisting to the module during assembly.
- (2) To assemble or install module into user's system can be only in clean working areas. The dust and oil may cause electrical short or worsen the polarizer.
- (3) It's not permitted to have pressure or impulse on the module because the LCD panel and Backlight will be damaged.
- (4) Always follow the correct power sequence when LCD module is connecting and operating. This can prevent damage to the CMOS LSI chips during latch-up.
- (5) Do not pull the I/F connector in or out while the module is operating.
- (6) Do not disassemble the module.
- (7) Use a soft dry cloth without chemicals for cleaning, because the surface of polarizer is very soft and easily scratched.
- (8) It is dangerous that moisture come into or contacted the LCD module, because moisture may damage LCD module when it is operating.
- (9) High temperature or humidity may reduce the performance of module. Please store LCD module within the specified storage conditions.
- (10) When ambient temperature is lower than 10°C may reduce the display quality. For example, the response time will become slowly, and the starting voltage of CCFL will be higher than room temperature.

### 10.2 SAFETY PRECAUTIONS

- (1) The startup voltage of Backlight is approximately 1000 Volts. It may cause electrical shock while assembling with inverter. Do not disassemble the module or insert anything into the Backlight unit.
- (2) If the liquid crystal material leaks from the panel, it should be kept away from the eyes or mouth. In case of contact with hands, skin or clothes, it has to be washed away thoroughly with soap.
- (3) After the module's end of life, it is not harmful in case of normal operation and storage.

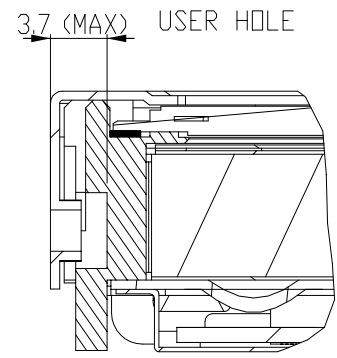

SECTION A-A  
SCALE 4.000

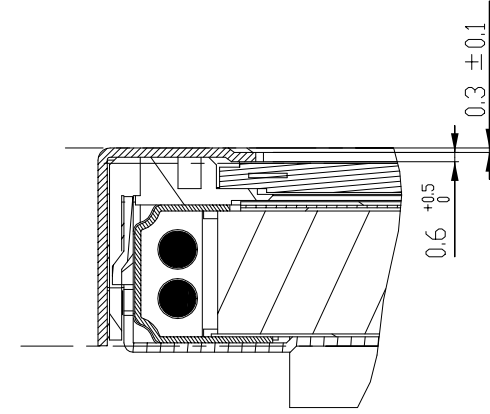

SECTION V-V  
SCALE 4.000

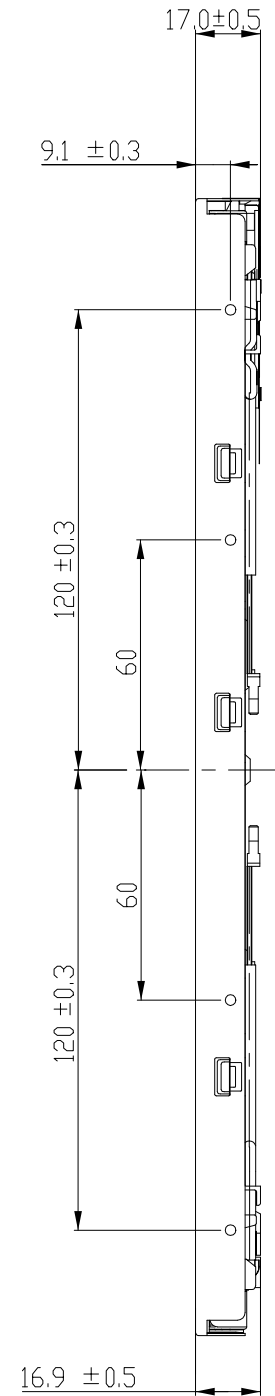
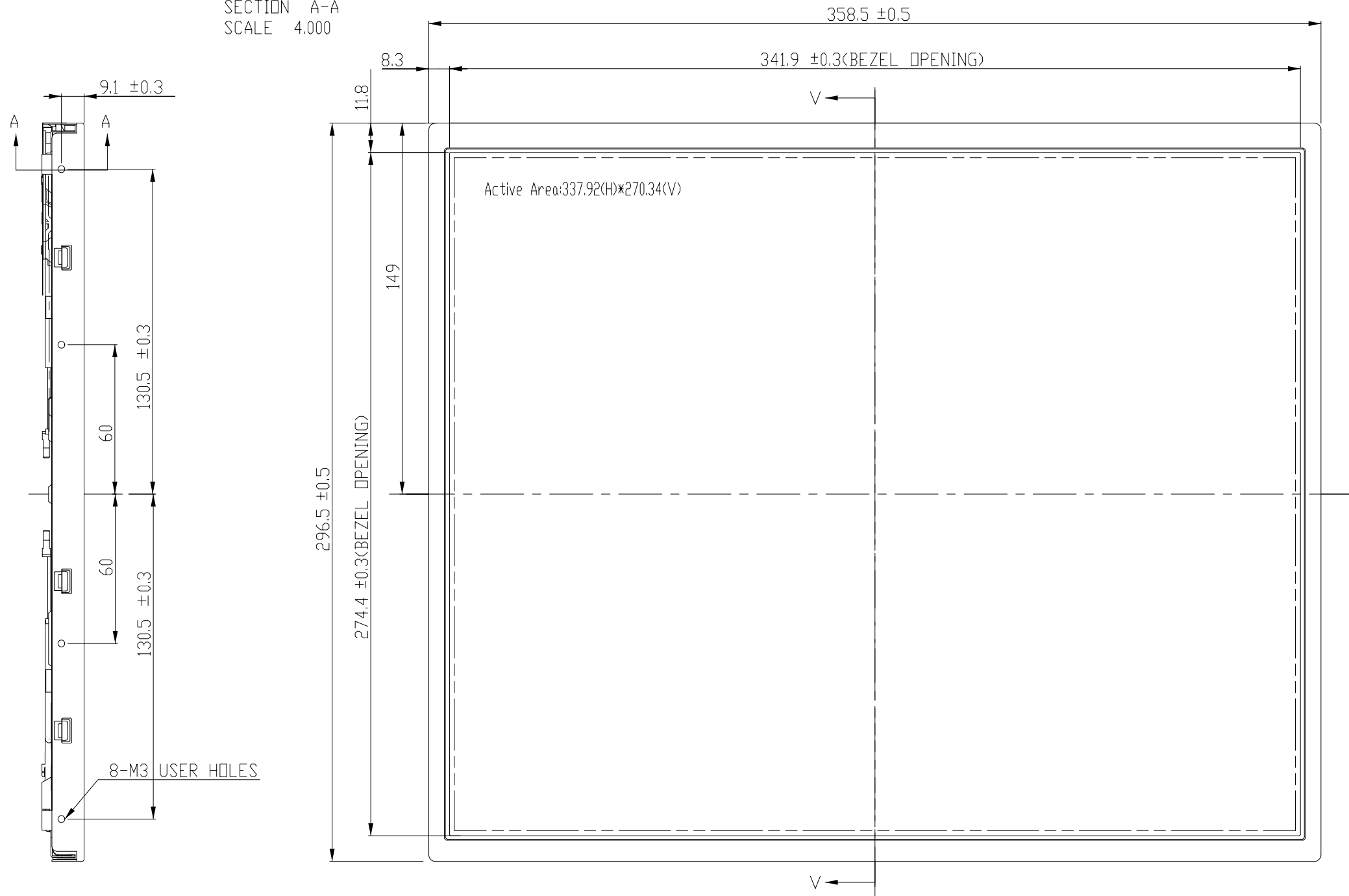

NOTES:  
1.GENERAL TOLERANCE:±0.3  
2.THE TORQUE FOR SIDE MOUNT SCREWS: 5kg-cm(Max.)

TITLE ASSY_MODULE_M170E5-L09 (MHOE509901)		2D REV.	
Approved JEMMY CHANG		3D REV.1.11+	
Checked ROCKY YANG	Drawing No. M170641201	Part No. TBD	
Drawer ICE RED	Material TBD	Sheet 1 / 2	AI
Designer ICE RED	Date 26-Mar-2005	Scale 1.000	Unitmm
CHI MEI OPTOELECTRONICS CORP.		ALL RIGHTS RESERVED, COPYING FORBIDDEN.	

Mark	Description	Date	Changed_By	Approved_By	ECN No.	Remark
1						
2						
3						
4						

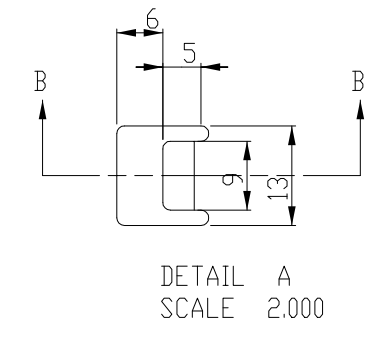
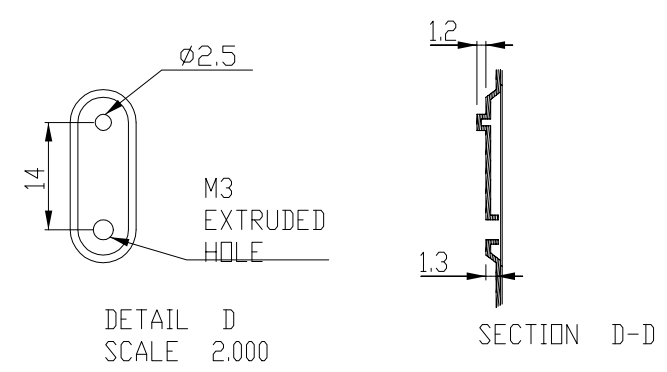
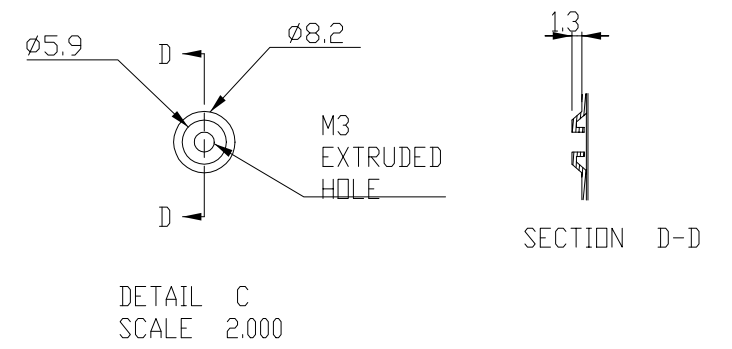
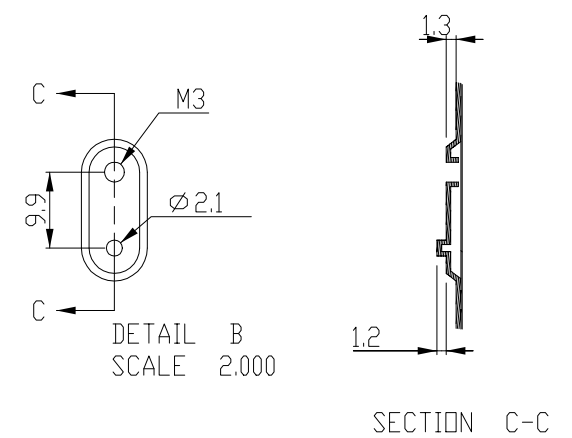
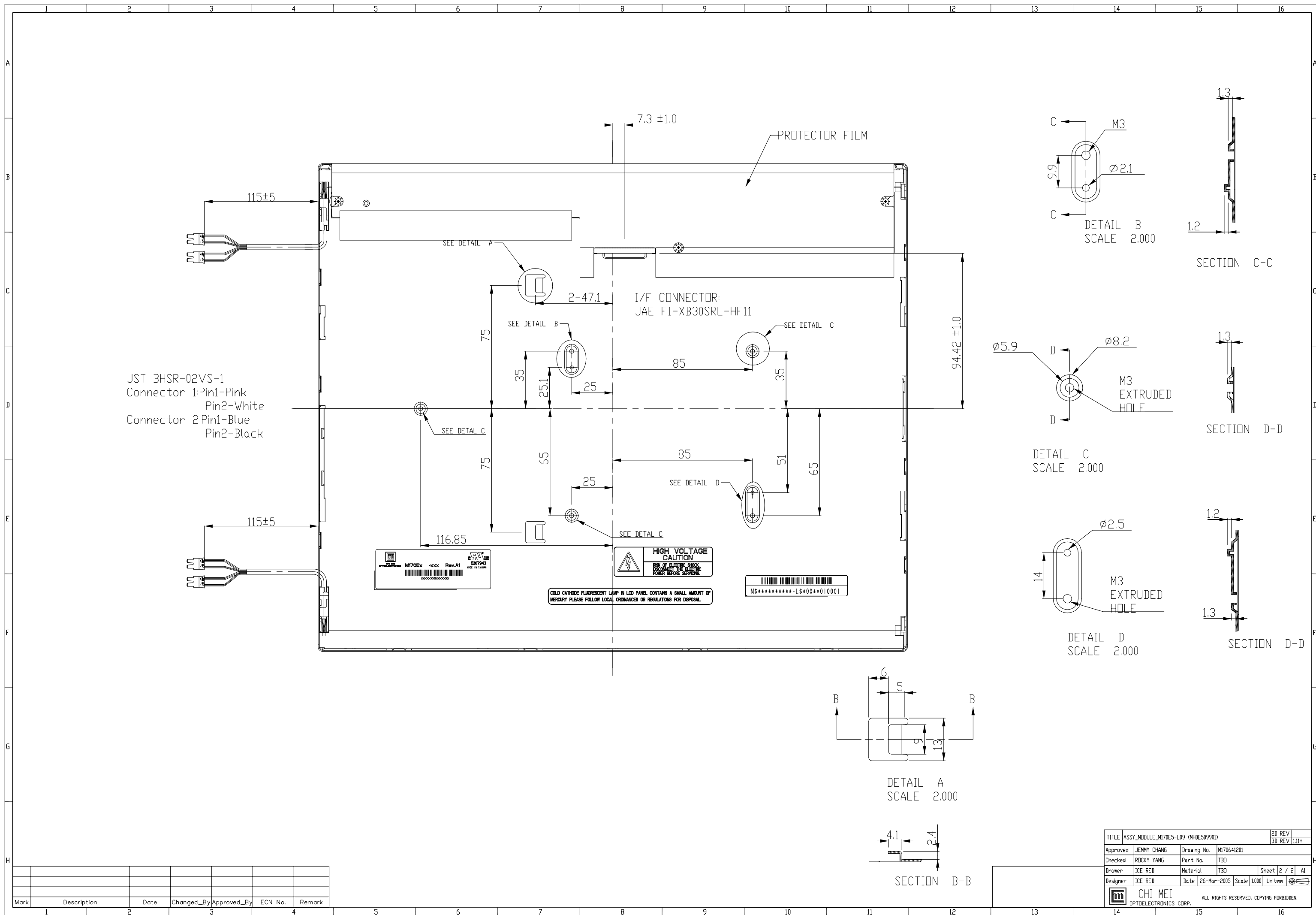

TITLE		ASSY_MODULE_M170E5-L09 (MH0E509901)		2D REV.	
Approved		JEMMY CHANG		3D REV.	1.11+
Checked	ROCKY YANG	Drawing No.	M170641201		
Drawer	ICE RED	Part No.	TBD	Sheet	2 / 2 AI
Designer	ICE RED	Date	26-Mar-2005	Scale	1.000
CHI MEI		OPTOELECTRONICS CORP.			
ALL RIGHTS RESERVED, COPYING FORBIDDEN.					

Mark	Description	Date	Changed_By	Approved_By	ECN No.	Remark
1						
2						
3						
4						