

TFT LCD Tentative Specification

MODEL NO.: M190A1-L0F

Customer: _____

Approved by: _____

Note:

- CONTENTS -

| | |
|--|-------|
| REVISION HISTORY | 3 |
| 1. GENERAL DESCRIPTION | 4 |
| 1.1 OVERVIEW | |
| 1.2 FEATURES | |
| 1.3 APPLICATION | |
| 1.4 GENERAL SPECIFICATIONS | |
| 1.5 MECHANICAL SPECIFICATIONS | |
| 2. ABSOLUTE MAXIMUM RATINGS | 5 |
| 2.1 ABSOLUTE RATINGS OF ENVIRONMENT | |
| 2.2 ELECTRICAL ABSOLUTE RATINGS | |
| 2.2.1 TFT LCD MODULE | |
| 2.2.2 BACKLIGHT UNIT | |
| 3. ELECTRICAL CHARACTERISTICS | 7 |
| 3.1.1 TFT LCD MODULE | |
| 3.1.2 Vcc Power Dip Condition | |
| 3.2 BACKLIGHT UNIT | |
| 4. BLOCK DIAGRAM..... | 11 |
| 4.1 TFT LCD MODULE | |
| 4.2 BACKLIGHT UNIT | |
| 5. INPUT TERMINAL PIN ASSIGNMENT | 12 |
| 5.1 TFT LCD MODULE | |
| 5.2 LVDS DATA MAPPING TABLE | |
| 5.3 BACKLIGHT UNIT | |
| 5.4 COLOR DATA INPUT ASSIGNMENT | |
| 6. INTERFACE TIMING | 15 |
| 6.1 INPUT SIGNAL TIMING SPECIFICATIONS | |
| 6.2 POWER ON/OFF SEQUENCE | |
| 7. OPTICAL CHARACTERISTICS..... | 17 |
| 7.1 TEST CONDITIONS | |
| 7.2 OPTICAL SPECIFICATIONS | |
| 8. PACKAGING | 20 |
| 8.1 PACKING SPECIFICATIONS | |
| 8.2 PACKING METHOD | |
| 9. DEFINITION OF LABELS..... | 22~23 |
| 10. PRECAUTIONS..... | 23 |
| 10.1 ASSEMBLY AND HANDLING PRECAUTIONS | |
| 10.2 SAFETY PRECAUTIONS | |
| 11. MECHANICAL CHARACTERISTICS..... | 24 |

REVISION HISTORY

| | Date | Section | Description |
|-----|---------------|----------------|---|
| 0.0 | Sep., 22, 08' | All | M190A1-L0F Specifications was first issued. |

1. GENERAL DESCRIPTION

1.1 OVERVIEW

M190A1-L0F is a 19" wide TFT Liquid Crystal Display module with 2 CCFL Backlight unit and 30 pins 2ch-LVDS interface. This module supports 1440 x 900 WXGA+ mode and can display 16.7M colors. The inverter module for Backlight is not built in.

1.2 FEATURES

- Super Wide viewing angle.
- Super High contrast ratio
- Super fast response time
- High color saturation
- WXGA+ (1440 x 900 pixels) resolution
- DE (Data Enable) only mode
- LVDS (Low Voltage Differential Signaling) interface
- RoHS Compliance

1.3 APPLICATION

- TFT LCD Monitor

1.4 GENERAL SPECIFICATIONS

| Item | Specification | Unit | Note |
|--------------------------|---|-------|------|
| Diagonal Size | 481.4 (18.95" diagonal) | mm | |
| Active Area | 408.24 (H) x 255.15 (V) | mm | (1) |
| Bezel Opening Area | 412.24 (H) x 259.15 (V) | mm | |
| Driver Element | a-si TFT active matrix | - | - |
| Pixel Number | 1440 x R.G.B. x 900 | pixel | - |
| Pixel Pitch | 0.2835 (H) x 0.2835 (V) | mm | - |
| Pixel Arrangement | RGB vertical stripe | - | - |
| Display Colors | 16.7M | color | - |
| Transmissive Mode | Normally White | - | - |
| Color Saturation | 72%NTSC (typ.) | | |
| Surface Treatment | Hard coating (3H), Anti-glare (Haze 25) | - | - |
| Module Power Consumption | 14.3 | Watt | (2) |

1.5 MECHANICAL SPECIFICATIONS

| Item | Min. | Typ. | Max. | Unit | Note | |
|-------------|---------------|-------|------|-------|------|-----|
| Module Size | Horizontal(H) | 427.5 | 428 | 428.5 | mm | (1) |
| | Vertical(V) | 277.5 | 278 | 278.5 | mm | |
| | Depth(D) | - | 16.2 | 16.7 | mm | |
| Weight | - | 2050 | 2200 | g | - | |

Note (1) Please refer to the attached drawings for more information of front and back outline dimensions.

Note (2) Please refer to sec.3.1 & 3.2 for more information of power consumption

2. ABSOLUTE MAXIMUM RATINGS

2.1 ABSOLUTE RATINGS OF ENVIRONMENT

| Item | Symbol | Value | | Unit | Note |
|-------------------------------|------------------|-------|------|------|----------|
| | | Min. | Max. | | |
| Storage Temperature | T _{ST} | -20 | +60 | °C | (1) |
| Operating Ambient Temperature | T _{OP} | 0 | +50 | °C | (1), (2) |
| Shock (Non-Operating) | S _{NOP} | - | 50 | G | (3), (5) |
| Vibration (Non-Operating) | V _{NOP} | - | 1.5 | G | (4), (5) |

Note (1) Temperature and relative humidity range is shown in the figure below.

(a) 90 %RH Max. ($T_a \leq 40$ °C).

(b) Wet-bulb temperature should be 39 °C Max. ($T_a > 40$ °C).

(c) No condensation.

Note (2) The temperature of panel display surface area should be 0 °C Min. and 60 °C Max.

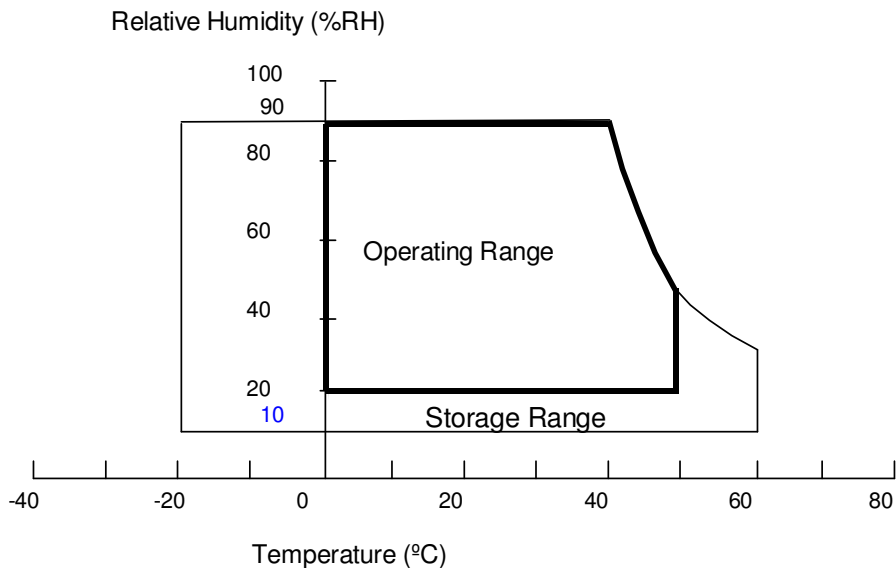

Note (3) 50G/11ms, half sine wave, 1 time for $\pm X$, $\pm Y$, $\pm Z$.

Note (4) 10 ~ 300 Hz, 10min/cycle, 3 cycles each X, Y, Z.

Note (5) At testing Vibration and Shock, the fixture in holding the module has to be hard and rigid enough so that the module would not be twisted or bent by the fixture.

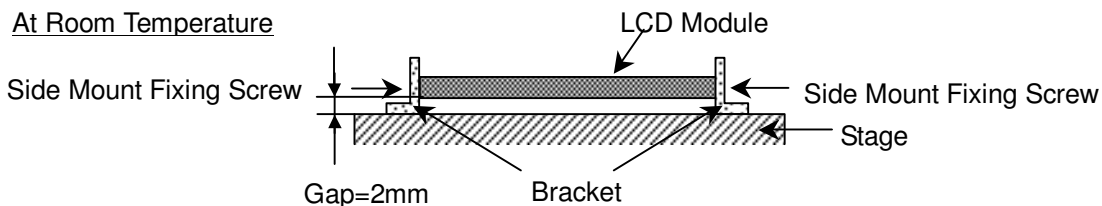

2.2 ELECTRICAL ABSOLUTE RATINGS

2.2.1 TFT LCD MODULE

| Item | Symbol | Value | | Unit | Note |
|----------------------|--------|-------|------|------|------|
| | | Min. | Max. | | |
| Power Supply Voltage | Vcc | -0.3 | +6.0 | V | (1) |

2.2.2 BACKLIGHT UNIT

| Item | Symbol | Value | | Unit | Note |
|----------------|--------|-------|------|------------|-------------------------|
| | | Min. | Max. | | |
| Lamp Voltage | V_L | - | 2.0K | V_{RMS} | (1), (2), $I_L = 7.5mA$ |
| Lamp Current | I_L | - | 8.0 | mA_{RMS} | (1), (2) |
| Lamp Frequency | F_L | - | 80 | KHz | |

Note (1) Permanent damage to the device may occur if maximum values are exceeded. Function operation should be restricted to the conditions described under Normal Operating Conditions.

Note (2) Specified values are for lamp (Refer to 3.2 for further information).

3. ELECTRICAL CHARACTERISTICS

3.1 TFT LCD MODULE

Ta = 25 ± 2 °C

| Parameter | Symbol | Value | | | Unit | Note |
|---------------------------------|-------------------|-------|------|------|------|------|
| | | Min. | Typ. | Max. | | |
| Power Supply Voltage | V _{CC} | 4.5 | 5.0 | 5.5 | V | - |
| Ripple Voltage | V _{RP} | - | - | 100 | mV | - |
| Rush Current | I _{RUSH} | - | - | 3 | A | (2) |
| Power Supply Current | White | - | 0.38 | 0.46 | A | (3)a |
| | Black | - | 0.58 | 0.69 | A | (3)b |
| | Vertical Stripe | - | 0.56 | 0.67 | A | (3)c |
| Power Consumption | PL _{CD} | | 2.9 | | Watt | (4) |
| LVDS differential input voltage | V _{id} | 100 | - | 600 | mV | |
| LVDS common input voltage | V _{ic} | - | 1.2 | - | V | |

Note (1) The module should be always operated within above ranges.

Note (2) Measurement Conditions:

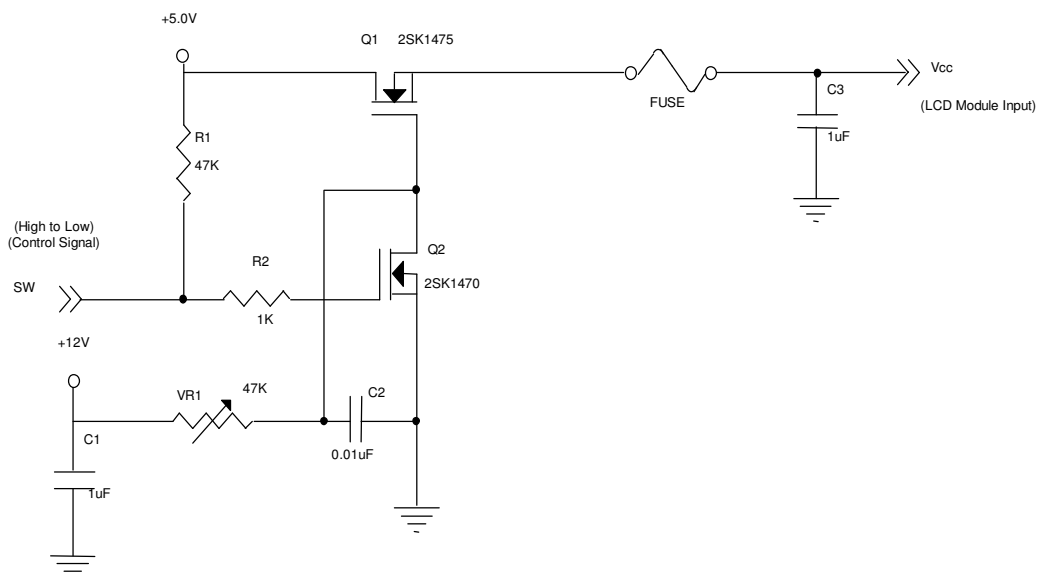

Vcc rising time is 470μs

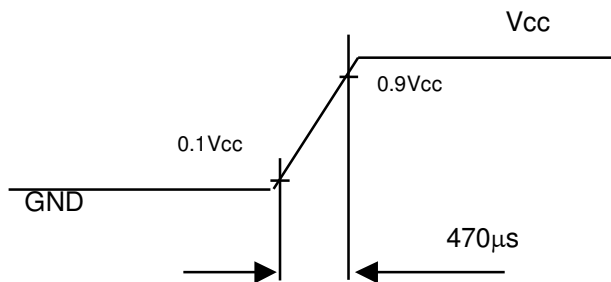

Note (3) The specified power supply current is under the conditions at $V_{cc} = 5.0\text{ V}$, $T_a = 25 \pm 2\text{ }^\circ\text{C}$, $f_v = 60\text{ Hz}$, whereas a power dissipation check pattern below is displayed.

a. White Pattern



Active Area

b. Black Pattern



Active Area

c. Vertical Stripe Pattern

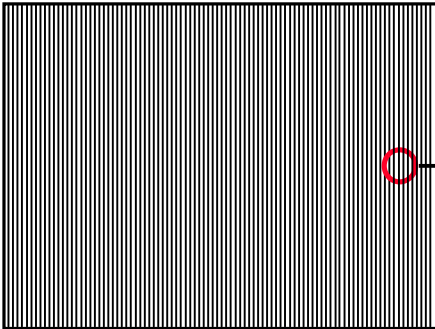

Active Area

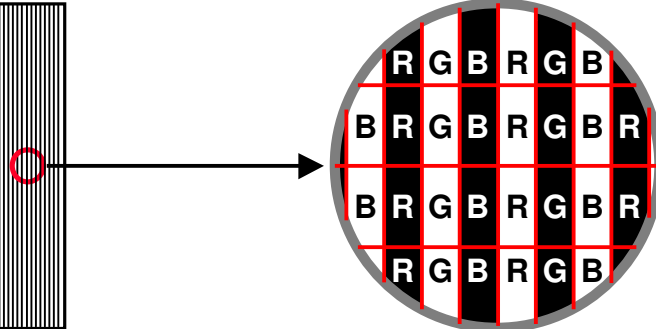

Note (4) The power consumption is specified at the pattern with the maximum current

3.2 V_{cc} POWER DIP CONDITION:

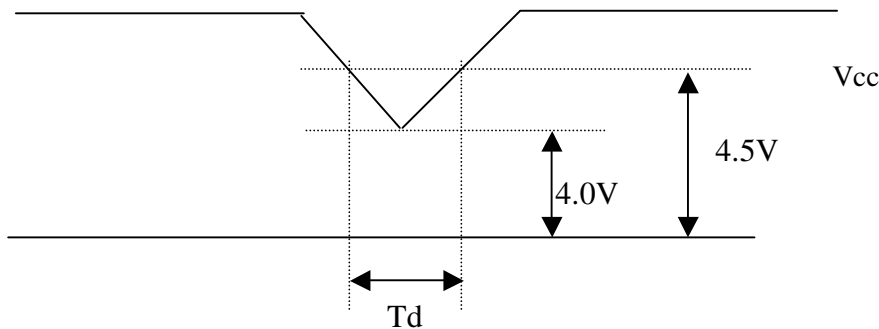

Dip condition: $4.0\text{V} \leq V_{cc} \leq 4.5\text{V}$, $T_d \leq 20\text{ms}$

3.3 BACKLIGHT UNIT

Ta = 25 ± 2 °C

| Parameter | Symbol | Value | | | Unit | Note |
|----------------------|-----------------|---------|--------|------------|-------------------|------------------------------|
| | | Min. | Typ. | Max. | | |
| Lamp Input Voltage | V _L | 684 | 760 | 836 | V _{RMS} | I _L = 7.5 mA |
| Lamp Current | I _L | 2.0 | 7.5 | 8.0 | mA _{RMS} | (1) |
| Lamp Turn On Voltage | V _S | --- | --- | 1500(25°C) | V _{RMS} | (2) |
| | | --- | --- | 1710(0°C) | V _{RMS} | (2) |
| Operating Frequency | F _L | 40 | --- | 80 | KHz | (3) |
| Lamp Life Time | L _{BL} | (30000) | --- | --- | Hrs | (5) |
| Power Consumption | P _L | --- | (11.4) | --- | W | (4), I _L = 7.5 mA |

Note (1) Lamp current is measured by utilizing high frequency current meters as shown below:

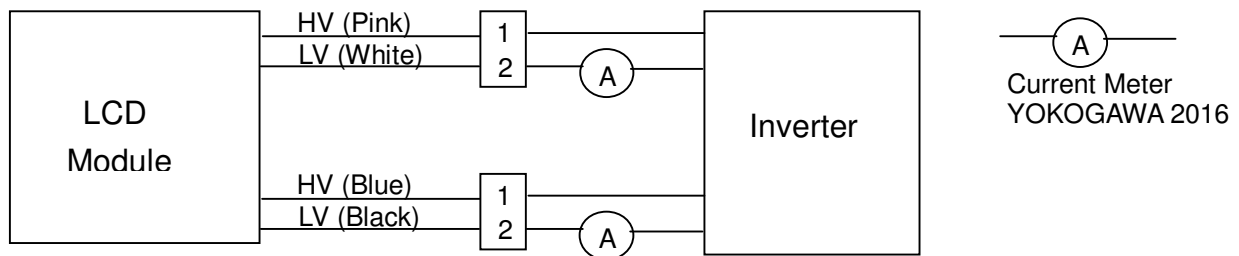

Note (2) The voltage shown above should be applied to the lamp for more than 1 second after startup. Otherwise the lamp may not be turned on.

Note (3) The lamp frequency may produce interference with horizontal synchronous frequency from the display, and this may cause line flow on the display. In order to avoid interference, the lamp frequency should be detached from the horizontal synchronous frequency and its harmonics as far as possible.

Note (4) $P_L = I_L \times V_L \times 2$ CCFLs

Note (5) The lifetime of lamp can be defined as the time in which it continues to operate under the condition Ta = 25 ± 2 °C and I_L = 6.0 mA rms until one of the following events occurs:

- (a) When the brightness becomes or lower than 50% of its original value.
- (b) When the effective ignition length becomes or lower than 80% of its original value. (Effective ignition length is defined as an area that has higher than 70% brightness compared to the brightness in the center point.)

Note (6) The waveform of the voltage output of inverter must be area-symmetric and the design of the inverter must have specifications for the modularized lamp. The performance of the Backlight, such as lifetime or brightness, is greatly influenced by the characteristics of the DC-AC inverter for the lamp. All the parameters of an inverter should be carefully designed to avoid producing too much current leakage from high voltage output of the inverter. When designing or ordering the inverter please make sure that a poor lighting caused by the mismatch of the Backlight and the inverter (miss-lighting, flicker, etc.) never occurs. If the above situation is confirmed, the module

should be operated in the same manners when it is installed in your instrument.

The output of the inverter must have symmetrical (negative and positive) voltage waveform and symmetrical current waveform. (Unsymmetrical ratio is less than 10%) Please do not use the inverter which has unsymmetrical voltage and unsymmetrical current and spike wave. Lamp frequency may produce interface with horizontal synchronous frequency and as a result this may cause beat on the display. Therefore lamp frequency shall be as away possible from the horizontal synchronous frequency and from its harmonics in order to prevent interference.

Requirements for a system inverter design, which is intended to have a better display performance, a better power efficiency and a more reliable lamp. It shall help increase the lamp lifetime and reduce its leakage current.

- a. The asymmetry rate of the inverter waveform should be 10% below;
- b. The distortion rate of the waveform should be within $\sqrt{2} \pm 10\%$;
- c. The ideal sine wave form shall be symmetric in positive and negative polarities.

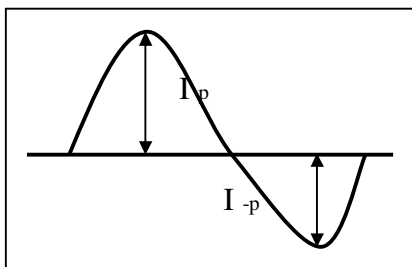

* Asymmetry rate:

$$\frac{|I_p - I_{-p}|}{I_{rms}} * 100\%$$

* Distortion rate

$$I_p \text{ (or } I_{-p}) / I_{rms}$$

4. BLOCK DIAGRAM

4.1 TFT LCD MODULE

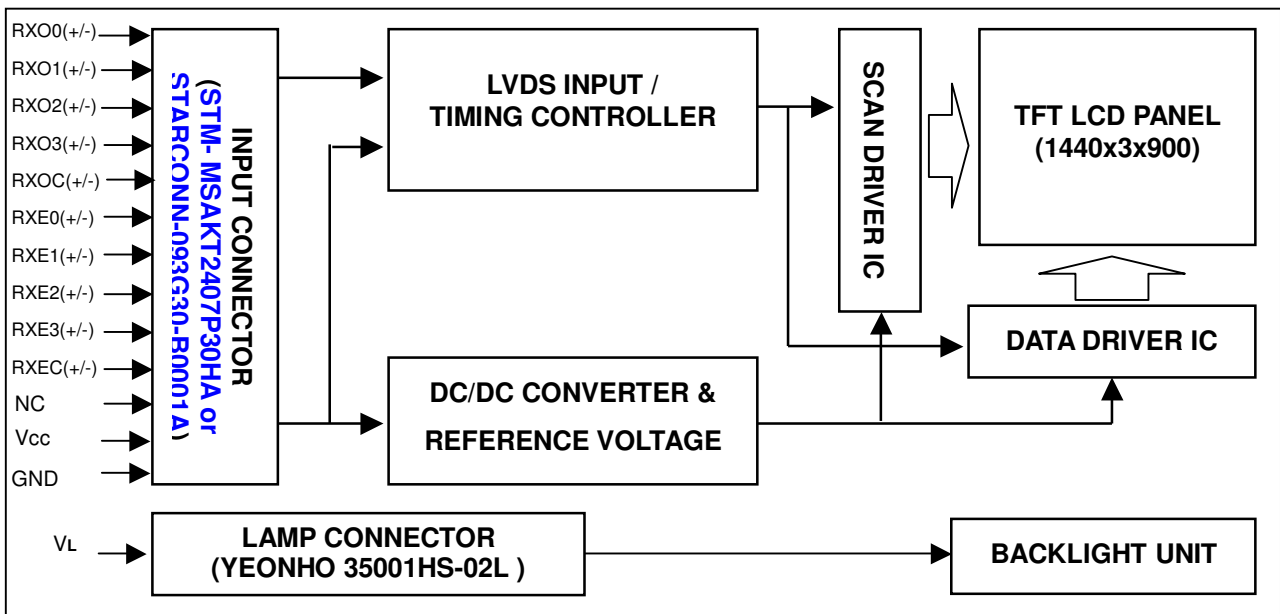

4.2 BACKLIGHT UNIT

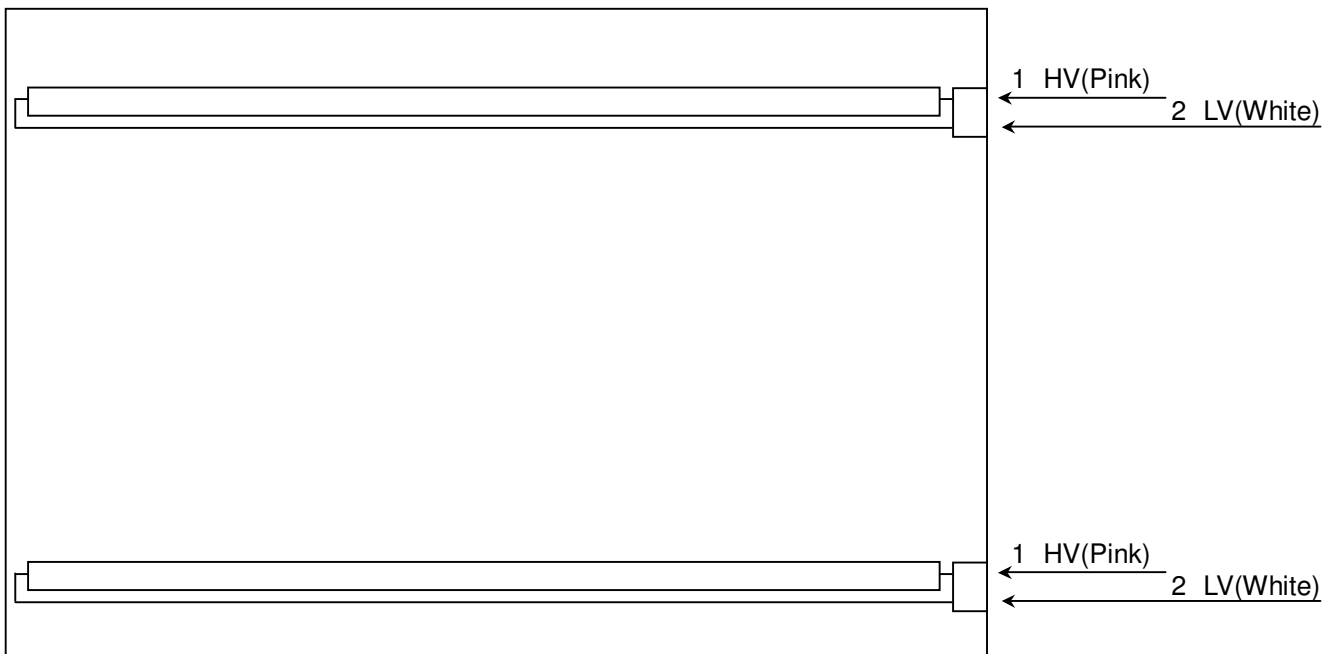

Note: On the same side, the same-polarity lamp voltage design for lamps is recommended.

5. INPUT TERMINAL PIN ASSIGNMENT

5.1 TFT LCD MODULE

| Pin | Name | Description |
|-----|-------|--|
| 1 | RXO0- | Negative LVDS differential data input. Channel O0 (odd) |
| 2 | RXO0+ | Positive LVDS differential data input. Channel O0 (odd) |
| 3 | RXO1- | Negative LVDS differential data input. Channel O1 (odd) |
| 4 | RXO1+ | Positive LVDS differential data input. Channel O1 (odd) |
| 5 | RXO2- | Negative LVDS differential data input. Channel O2 (odd) |
| 6 | RXO2+ | Positive LVDS differential data input. Channel O2 (odd) |
| 7 | GND | Ground |
| 8 | RXOC- | Negative LVDS differential clock input. (odd) |
| 9 | RXOC+ | Positive LVDS differential clock input. (odd) |
| 10 | RXO3- | Negative LVDS differential data input. Channel O3(odd) |
| 11 | RXO3+ | Positive LVDS differential data input. Channel O3 (odd) |
| 12 | RXE0- | Negative LVDS differential data input. Channel E0 (even) |
| 13 | RXE0+ | Positive LVDS differential data input. Channel E0 (even) |
| 14 | GND | Ground |
| 15 | RXE1- | Negative LVDS differential data input. Channel E1 (even) |
| 16 | RXE1+ | Positive LVDS differential data input. Channel E1 (even) |
| 17 | GND | Ground |
| 18 | RXE2- | Negative LVDS differential data input. Channel E2 (even) |
| 19 | RXE2+ | Positive LVDS differential data input. Channel E2 (even) |
| 20 | RXEC- | Negative LVDS differential clock input. (even) |
| 21 | RXEC+ | Positive LVDS differential clock input. (even) |
| 22 | RXE3- | Negative LVDS differential data input. Channel E3 (even) |
| 23 | RXE3+ | Positive LVDS differential data input. Channel E3 (even) |
| 24 | GND | Ground |
| 25 | NC | Not connection, this pin should be open. |
| 26 | NC | Not connection, this pin should be open. |
| 27 | NC | Not connection, this pin should be open. |
| 28 | VCC | +5.0V power supply |
| 29 | VCC | +5.0V power supply |
| 30 | VCC | +5.0V power supply |

Note (1) Connector Part No.: [STM-MSAKT2407P30HA](#) or [STARCONN-093G30-B0001A](#).

Note (2) The first pixel is odd.

Note (3) Input signal of even and odd clock should be the same timing.

5.2 LVDS DATA MAPPING TABLE

| | | | | | | | | |
|-----------------|-------------|-----|-----|-----|-----|-----|-----|-----|
| LVDS Channel O0 | LVDS output | D7 | D6 | D4 | D3 | D2 | D1 | D0 |
| | Data order | OG0 | OR5 | OR4 | OR3 | OR2 | OR1 | OR0 |
| LVDS Channel O1 | LVDS output | D18 | D15 | D14 | D13 | D12 | D9 | D8 |
| | Data order | OB1 | OB0 | OG5 | OG4 | OG3 | OG2 | OG1 |
| LVDS Channel O2 | LVDS output | D26 | D25 | D24 | D22 | D21 | D20 | D19 |
| | Data order | DE | NA | NA | OB5 | OB4 | OB3 | OB2 |
| LVDS Channel O3 | LVDS output | D23 | D17 | D16 | D11 | D10 | D5 | D27 |
| | Data order | NA | OB7 | OB6 | OG7 | OG6 | OR7 | OR6 |
| LVDS Channel E0 | LVDS output | D7 | D6 | D4 | D3 | D2 | D1 | D0 |
| | Data order | EG0 | ER5 | ER4 | ER3 | ER2 | ER1 | ER0 |
| LVDS Channel E1 | LVDS output | D18 | D15 | D14 | D13 | D12 | D9 | D8 |
| | Data order | EB1 | EB0 | EG5 | EG4 | EG3 | EG2 | EG1 |
| LVDS Channel E2 | LVDS output | D26 | D25 | D24 | D22 | D21 | D20 | D19 |
| | Data order | DE | NA | NA | EB5 | EB4 | EB3 | EB2 |
| LVDS Channel E3 | LVDS output | D23 | D17 | D16 | D11 | D10 | D5 | D27 |
| | Data order | NA | EB7 | EB6 | EG7 | EG6 | ER7 | ER6 |

5.3 BACKLIGHT UNIT

| Pin | Symbol | Description | Remark |
|-----|--------|--------------|--------|
| 1 | HV | High Voltage | Pink |
| 2 | LV | Low Voltage | White |

| | | | |
|---|----|--------------|-------|
| 1 | HV | High Voltage | Blue |
| 2 | LV | Low Voltage | Black |

Note (1) Connector Part No.: YEONHO 35001 HS-02L or equivalent

Note (2) User's connector Part No.: YEONHO 35001 WR-02L or equivalent

5.4 COLOR DATA INPUT ASSIGNMENT

The brightness of each primary color (red, green and blue) is based on the 8-bit gray scale data input for the color. The higher the binary input, the brighter the color. The table below provides the assignment of color versus data input.

| Color | | Data Signal | | | | | | | | | | | | | | | | | | | | | | | |
|---------------------|-----------------|-------------|----|----|----|----|----|----|----|-------|----|----|----|----|----|----|----|------|----|----|----|----|----|----|----|
| | | Red | | | | | | | | Green | | | | | | | | Blue | | | | | | | |
| | | R7 | R6 | R5 | R4 | R3 | R2 | R1 | R0 | R7 | R6 | G5 | G4 | G3 | G2 | G1 | G0 | R7 | R6 | B5 | B4 | B3 | B2 | B1 | B0 |
| Basic Colors | Black | 0 | 0 | 0 | 0 | 0 | 0 | 0 | 0 | 0 | 0 | 0 | 0 | 0 | 0 | 0 | 0 | 0 | 0 | 0 | 0 | 0 | 0 | 0 | 0 |
| | Red | 1 | 1 | 1 | 1 | 1 | 1 | 1 | 1 | 0 | 0 | 0 | 0 | 0 | 0 | 0 | 0 | 0 | 0 | 0 | 0 | 0 | 0 | 0 | 0 |
| | Green | 0 | 0 | 0 | 0 | 0 | 0 | 0 | 0 | 1 | 1 | 1 | 1 | 1 | 1 | 1 | 1 | 0 | 0 | 0 | 0 | 0 | 0 | 0 | 0 |
| | Blue | 0 | 0 | 0 | 0 | 0 | 0 | 0 | 0 | 0 | 0 | 0 | 0 | 0 | 0 | 0 | 0 | 1 | 1 | 1 | 1 | 1 | 1 | 1 | 1 |
| | Cyan | 0 | 0 | 0 | 0 | 0 | 0 | 0 | 0 | 1 | 1 | 1 | 1 | 1 | 1 | 1 | 1 | 1 | 1 | 1 | 1 | 1 | 1 | 1 | 1 |
| | Magenta | 1 | 1 | 1 | 1 | 1 | 1 | 1 | 1 | 0 | 0 | 0 | 0 | 0 | 0 | 0 | 0 | 1 | 1 | 1 | 1 | 1 | 1 | 1 | 1 |
| | Yellow | 1 | 1 | 1 | 1 | 1 | 1 | 1 | 1 | 1 | 1 | 1 | 1 | 1 | 1 | 1 | 1 | 0 | 0 | 0 | 0 | 0 | 0 | 0 | 0 |
| | White | 1 | 1 | 1 | 1 | 1 | 1 | 1 | 1 | 1 | 1 | 1 | 1 | 1 | 1 | 1 | 1 | 1 | 1 | 1 | 1 | 1 | 1 | 1 | 1 |
| Gray Scale Of Red | Red(0) / Dark | 0 | 0 | 0 | 0 | 0 | 0 | 0 | 0 | 0 | 0 | 0 | 0 | 0 | 0 | 0 | 0 | 0 | 0 | 0 | 0 | 0 | 0 | 0 | 0 |
| | Red(1) | 0 | 0 | 0 | 0 | 0 | 0 | 0 | 1 | 0 | 0 | 0 | 0 | 0 | 0 | 0 | 0 | 0 | 0 | 0 | 0 | 0 | 0 | 0 | 0 |
| | Red(2) | 0 | 0 | 0 | 0 | 0 | 0 | 1 | 0 | 0 | 0 | 0 | 0 | 0 | 0 | 0 | 0 | 0 | 0 | 0 | 0 | 0 | 0 | 0 | 0 |
| | ⋮ | ⋮ | ⋮ | ⋮ | ⋮ | ⋮ | ⋮ | ⋮ | ⋮ | ⋮ | ⋮ | ⋮ | ⋮ | ⋮ | ⋮ | ⋮ | ⋮ | ⋮ | ⋮ | ⋮ | ⋮ | ⋮ | ⋮ | ⋮ | ⋮ |
| | ⋮ | ⋮ | ⋮ | ⋮ | ⋮ | ⋮ | ⋮ | ⋮ | ⋮ | ⋮ | ⋮ | ⋮ | ⋮ | ⋮ | ⋮ | ⋮ | ⋮ | ⋮ | ⋮ | ⋮ | ⋮ | ⋮ | ⋮ | ⋮ | ⋮ |
| | Red(253) | 1 | 1 | 1 | 1 | 1 | 1 | 0 | 1 | 0 | 0 | 0 | 0 | 0 | 0 | 0 | 0 | 0 | 0 | 0 | 0 | 0 | 0 | 0 | 0 |
| | Red(254) | 1 | 1 | 1 | 1 | 1 | 1 | 1 | 0 | 0 | 0 | 0 | 0 | 0 | 0 | 0 | 0 | 0 | 0 | 0 | 0 | 0 | 0 | 0 | 0 |
| | Red(255) | 1 | 1 | 1 | 1 | 1 | 1 | 1 | 1 | 0 | 0 | 0 | 0 | 0 | 0 | 0 | 0 | 0 | 0 | 0 | 0 | 0 | 0 | 0 | 0 |
| Gray Scale Of Green | Green(0) / Dark | 0 | 0 | 0 | 0 | 0 | 0 | 0 | 0 | 0 | 0 | 0 | 0 | 0 | 0 | 0 | 0 | 0 | 0 | 0 | 0 | 0 | 0 | 0 | 0 |
| | Green(1) | 0 | 0 | 0 | 0 | 0 | 0 | 0 | 0 | 0 | 0 | 0 | 0 | 0 | 0 | 0 | 1 | 0 | 0 | 0 | 0 | 0 | 0 | 0 | 0 |
| | Green(2) | 0 | 0 | 0 | 0 | 0 | 0 | 0 | 0 | 0 | 0 | 0 | 0 | 0 | 0 | 1 | 0 | 0 | 0 | 0 | 0 | 0 | 0 | 0 | 0 |
| | ⋮ | ⋮ | ⋮ | ⋮ | ⋮ | ⋮ | ⋮ | ⋮ | ⋮ | ⋮ | ⋮ | ⋮ | ⋮ | ⋮ | ⋮ | ⋮ | ⋮ | ⋮ | ⋮ | ⋮ | ⋮ | ⋮ | ⋮ | ⋮ | ⋮ |
| | ⋮ | ⋮ | ⋮ | ⋮ | ⋮ | ⋮ | ⋮ | ⋮ | ⋮ | ⋮ | ⋮ | ⋮ | ⋮ | ⋮ | ⋮ | ⋮ | ⋮ | ⋮ | ⋮ | ⋮ | ⋮ | ⋮ | ⋮ | ⋮ | ⋮ |
| | Green(253) | 0 | 0 | 0 | 0 | 0 | 0 | 0 | 0 | 1 | 1 | 1 | 1 | 1 | 1 | 0 | 1 | 0 | 0 | 0 | 0 | 0 | 0 | 0 | 0 |
| | Green(254) | 0 | 0 | 0 | 0 | 0 | 0 | 0 | 0 | 1 | 1 | 1 | 1 | 1 | 1 | 0 | 0 | 0 | 0 | 0 | 0 | 0 | 0 | 0 | 0 |
| | Green(255) | 0 | 0 | 0 | 0 | 0 | 0 | 0 | 0 | 1 | 1 | 1 | 1 | 1 | 1 | 1 | 0 | 0 | 0 | 0 | 0 | 0 | 0 | 0 | 0 |
| Gray Scale Of Blue | Blue(0) / Dark | 0 | 0 | 0 | 0 | 0 | 0 | 0 | 0 | 0 | 0 | 0 | 0 | 0 | 0 | 0 | 0 | 0 | 0 | 0 | 0 | 0 | 0 | 0 | 0 |
| | Blue(1) | 0 | 0 | 0 | 0 | 0 | 0 | 0 | 0 | 0 | 0 | 0 | 0 | 0 | 0 | 0 | 0 | 0 | 0 | 0 | 0 | 0 | 0 | 0 | 1 |
| | Blue(2) | 0 | 0 | 0 | 0 | 0 | 0 | 0 | 0 | 0 | 0 | 0 | 0 | 0 | 0 | 0 | 0 | 0 | 0 | 0 | 0 | 0 | 0 | 1 | 0 |
| | ⋮ | ⋮ | ⋮ | ⋮ | ⋮ | ⋮ | ⋮ | ⋮ | ⋮ | ⋮ | ⋮ | ⋮ | ⋮ | ⋮ | ⋮ | ⋮ | ⋮ | ⋮ | ⋮ | ⋮ | ⋮ | ⋮ | ⋮ | ⋮ | ⋮ |
| | ⋮ | ⋮ | ⋮ | ⋮ | ⋮ | ⋮ | ⋮ | ⋮ | ⋮ | ⋮ | ⋮ | ⋮ | ⋮ | ⋮ | ⋮ | ⋮ | ⋮ | ⋮ | ⋮ | ⋮ | ⋮ | ⋮ | ⋮ | ⋮ | ⋮ |
| | Blue(253) | 0 | 0 | 0 | 0 | 0 | 0 | 0 | 0 | 0 | 0 | 0 | 0 | 0 | 0 | 0 | 1 | 1 | 1 | 1 | 1 | 1 | 1 | 0 | 1 |
| | Blue(254) | 0 | 0 | 0 | 0 | 0 | 0 | 0 | 0 | 0 | 0 | 0 | 0 | 0 | 0 | 0 | 1 | 1 | 1 | 1 | 1 | 1 | 1 | 1 | 0 |
| | Blue(255) | 0 | 0 | 0 | 0 | 0 | 0 | 0 | 0 | 0 | 0 | 0 | 0 | 0 | 0 | 0 | 1 | 1 | 1 | 1 | 1 | 1 | 1 | 1 | 1 |

Note (1) 0: Low Level Voltage, 1: High Level Voltage

6. INTERFACE TIMING

6.1 INPUT SIGNAL TIMING SPECIFICATIONS

The input signal timing specifications are shown as the following table and timing diagram.

| Signal | Item | Symbol | Min. | Typ. | Max. | Unit | Note |
|--------------------------------|------------|-----------|----------------|------|----------------|-------|-------------------------|
| LVDS Clock | Frequency | F_c | 40 | 44.5 | 61 | MHz | - |
| | Period | T_c | 16.4 | 22.5 | 25 | ns | - |
| | High Time | T_{ch} | - | 4/7 | - | T_c | - |
| | Low Time | T_{cl} | - | 3/7 | - | T_c | - |
| LVDS Data | Setup Time | T_{lvs} | 600 | - | - | ps | - |
| | Hold Time | T_{lvh} | 600 | - | - | ps | - |
| Vertical Active Display Term | Frame Rate | F_r | 47 | 60 | 75 | Hz | $T_v = T_{vd} + T_{vb}$ |
| | Total | T_v | 905 | 926 | 1200 | T_h | - |
| | Display | T_{vd} | 900 | 900 | 900 | T_h | - |
| | Blank | T_{vb} | $T_v - T_{vd}$ | 26 | $T_v - T_{vd}$ | T_h | - |
| Horizontal Active Display Term | Total | T_h | 770 | 800 | 960 | T_c | $T_h = T_{hd} + T_{hb}$ |
| | Display | T_{hd} | 720 | 720 | 720 | T_c | - |
| | Blank | T_{hb} | $T_h - T_{hd}$ | 80 | $T_h - T_{hd}$ | T_c | - |

Note: Because this module is operated by DE only mode, Hsync and Vsync input signals should be set to low logic level or ground. Otherwise, this module would operate abnormally.

INPUT SIGNAL TIMING DIAGRAM

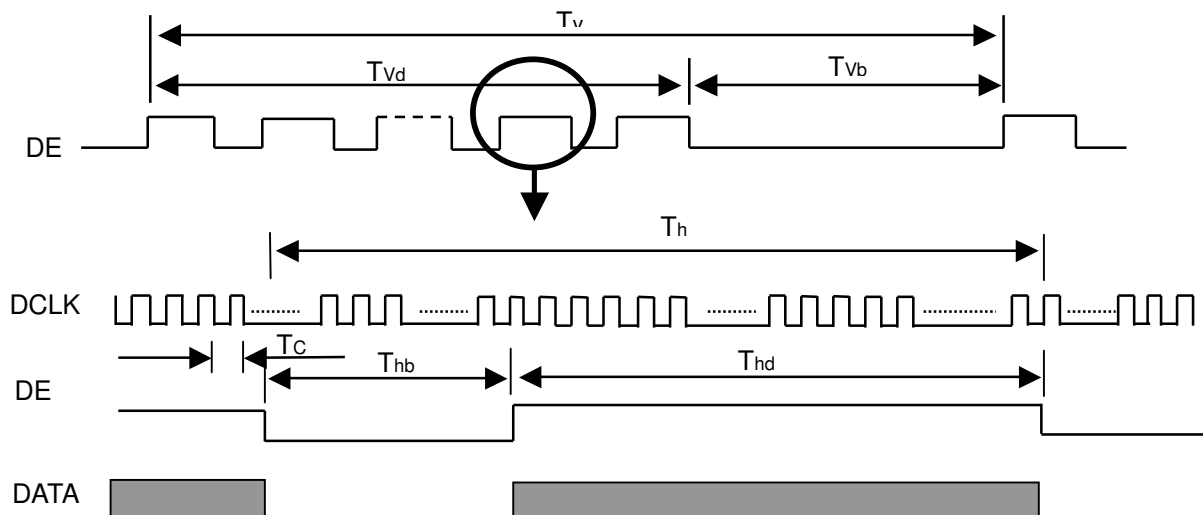

6.2 POWER ON/OFF SEQUENCE

To prevent a latch-up or DC operation of LCD module, the power on/off sequence should be as the diagram below.

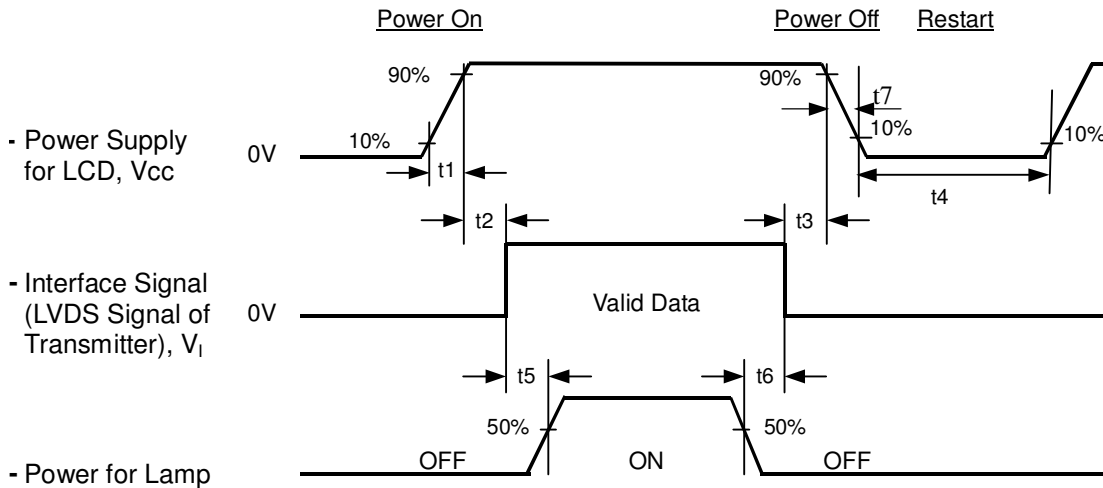

Timing Specifications:

- $0.5 < t1 \leq 10$ msec
- $0 < t2 \leq 50$ msec
- $0 < t3 \leq 50$ msec
- $t4 \geq 500$ msec
- $t5 \geq 450$ msec
- $t6 \geq 90$ msec
- $5 \leq t7 \leq 100$ msec

Note.

- (1) The supply voltage of the external system for the module input should be the same as the definition of Vcc.
- (2) Apply the lamp voltage within the LCD operation range. When the backlight turns on before the LCD operation of the LCD turns off before the backlight turns off, the display may momentarily become abnormal screen.
- (3) In case of VCC = off level, please keep the level of input signals on the low or keep a high impedance.
- (4) T4 should be measured after the module has been fully discharged between power off and on period.
- (5) Interface signal shall not be kept at high impedance when the power is on.

The company will not guarantee or compensate for the product damage caused by not following the Power Sequence

7. OPTICAL CHARACTERISTICS

7.1 TEST CONDITIONS

| Item | Symbol | Value | Unit |
|------------------------------|---|-------|------|
| Ambient Temperature | Ta | 25±2 | °C |
| Ambient Humidity | Ha | 50±10 | %RH |
| Supply Voltage | V _{CC} | 5.0 | V |
| Input Signal | According to typical value in "3. ELECTRICAL CHARACTERISTICS" | | |
| Lamp Current | I _L | (7.5) | mA |
| Inverter Operating Frequency | F _L | 55 | KHz |
| Inverter | Darfon VK.13165.101 | | |

7.2 OPTICAL SPECIFICATIONS

The relative measurement methods of optical characteristics are shown in 7.2. The following items should be measured under the test conditions described in 7.1 and stable environment shown in Note (5).

| Item | Symbol | Condition | Min. | Typ. | Max. | Unit | Note | |
|---------------------------|----------------|--|---------------|---------|---------------|-------------------|----------|----------|
| Color Chromaticity | Red | $\theta_x=0^\circ, \theta_y=0^\circ$ CS-1000T | Typ - 0.03 | (0.647) | Typ + 0.03 | | (1), (5) | |
| | | | | (0.334) | | | | |
| | Green | | | (0.284) | | | | |
| | | | | (0.607) | | | | |
| | Blue | | | (0.151) | | | | |
| | | | | (0.071) | | | | |
| | White | | | 0.313 | | | | |
| | | | | 0.329 | | | | |
| Center Luminance of White | L _C | | (230) | 300 | --- | cd/m ² | (4), (5) | |
| Contrast Ratio | CR | | 630 | 1000 | --- | - | (2), (5) | |
| Response Time | T _R | $\theta_x=0^\circ, \theta_y=0^\circ$ | --- | 1.5 | 6.5 | ms | (3) | |
| | T _F | | | 3.5 | 8.5 | ms | | |
| White Variation | δW | $\theta_x=0^\circ, \theta_y=0^\circ$ | --- | 1.3 | 1.5 | - | (5), (6) | |
| Viewing Angle | Horizontal | CR ≥ 10 | | 75 | 85 | --- | Deg. | (1), (5) |
| | | | | 75 | 85 | --- | | |
| | Vertical | | | 70 | 80 | --- | | |
| | | | | 70 | 80 | --- | | |

Note (1) Definition of Viewing Angle (θ_x, θ_y):

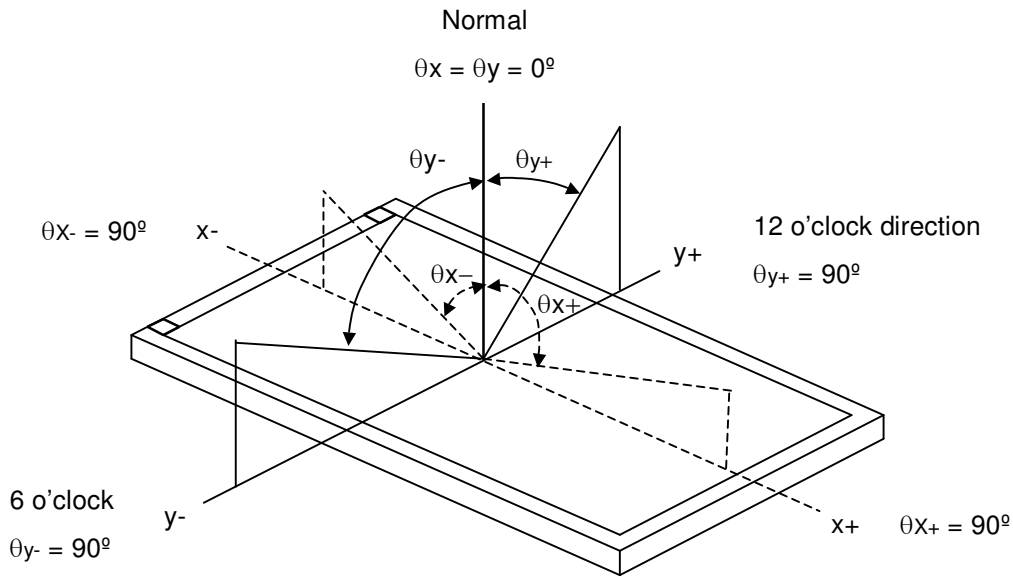

Note (2) Definition of Contrast Ratio (CR):

The contrast ratio can be calculated by the following expression.

$$\text{Contrast Ratio (CR)} = L_{255} / L_0$$

L255: Luminance of gray level 255

L 0: Luminance of gray level 0

$$CR = CR(1)$$

CR (X) is corresponding to the Contrast Ratio of the point X at Figure in Note (6).

Note (3) Definition of Response Time (T_R, T_F):

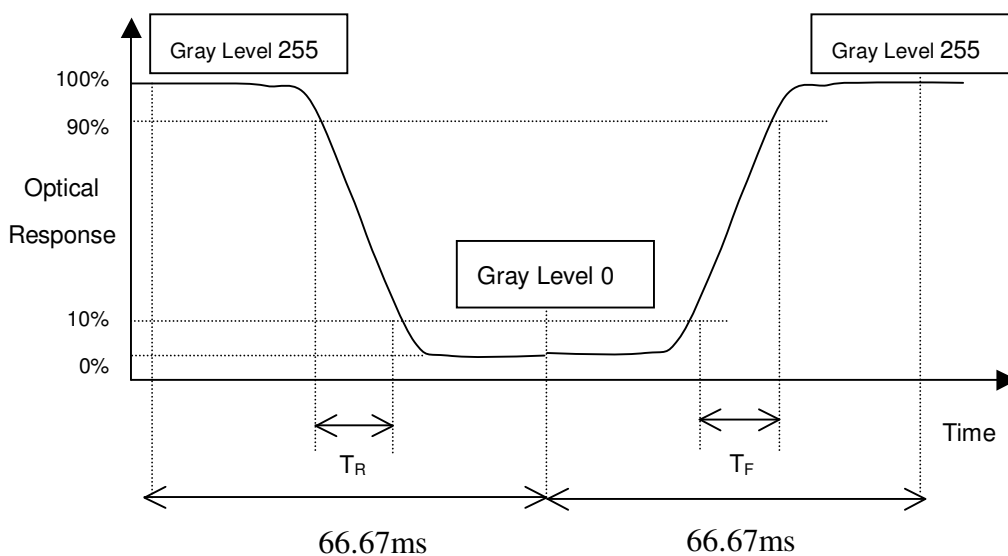

Note (4) Definition of Luminance of White (L_C):

Measure the luminance of gray level 255 at center point

$$L_C = L(1)$$

$L(x)$ is corresponding to the luminance of the point X at Figure in Note (6).

Note (5) Measurement Setup:

The LCD module should be stabilized at given temperature for 40 minutes to avoid abrupt temperature change during measuring. In order to stabilize the luminance, the measurement should be executed after lighting Backlight for 40 minutes in a windless room.

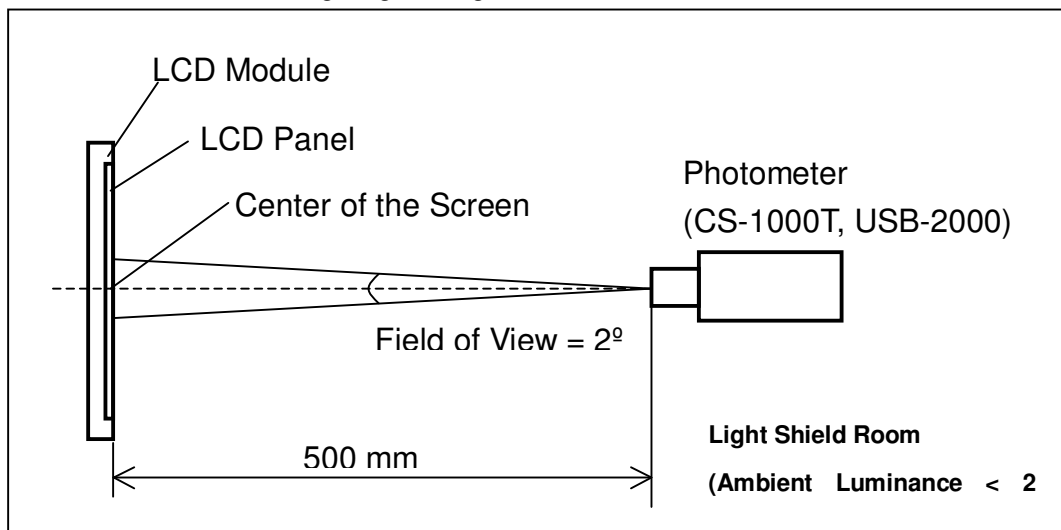

Note (6) Definition of White Variation (δW):

Measure the luminance of gray level 255 at 13 points

$$\delta W = \text{Maximum } [L(1), L(2) \dots L(4), L(13)] / \text{Minimum } [L(1), L(2) \dots L(4), L(13)]$$

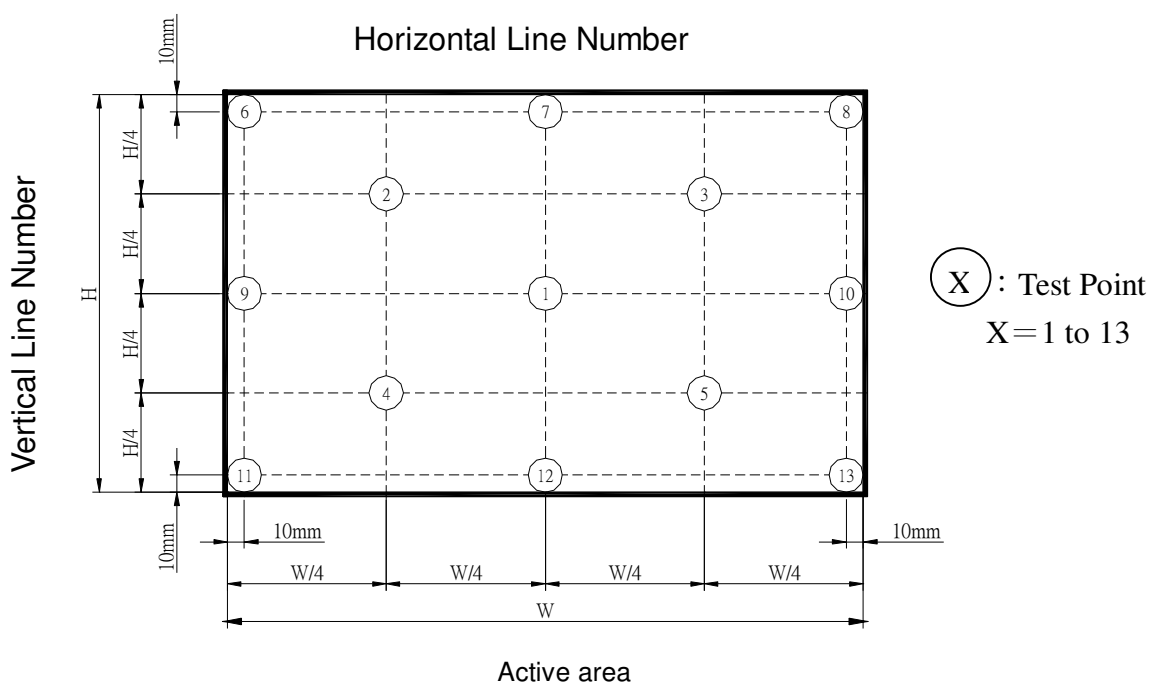

8. PACKAGING

8.1 PACKING SPECIFICATIONS

- (1) 7 LCD modules / 1 Box
- (2) Box dimensions: 525(L) X 300 (W) X 360 (H) mm
- (3) Weight: approximately 16.32 Kg (7 modules per box)

8.2 PACKING METHOD

- (1) Carton Packing should have no failure in the following reliability test items.

| Test Item | Test Conditions | Note |
|---------------|--|---------------|
| Vibration | ISTA STANDARD Random, Frequency Range: 1 – 200 Hz Top & Bottom: 30 minutes (+Z), 10 min (-Z), Right & Left: 10 minutes (X) Back & Forth 10 minutes (Y) | Non Operation |
| Dropping Test | 1 Corner, 3 Edge, 6 Face, 61cm | Non Operation |

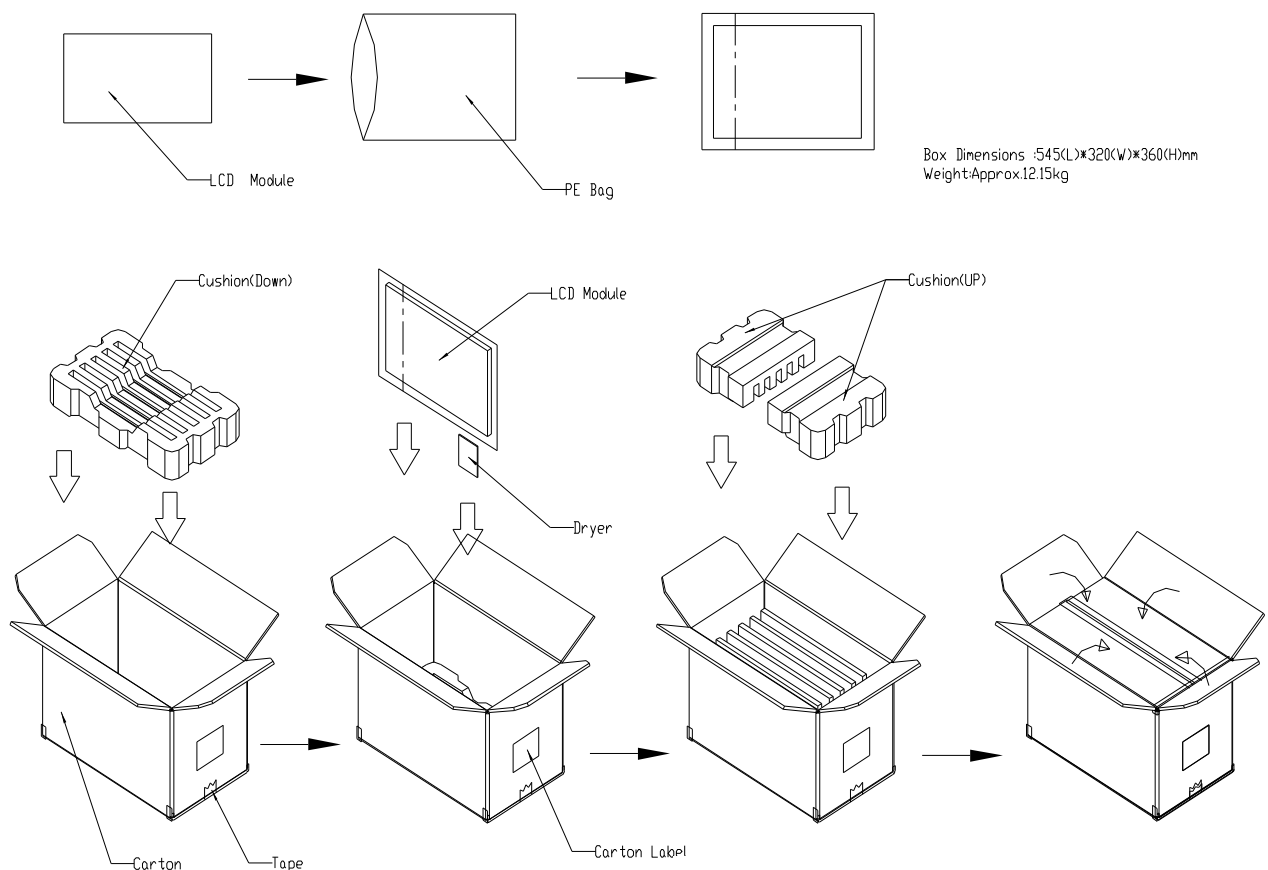

Figure. 8-1 Packing method

For ocean shipping

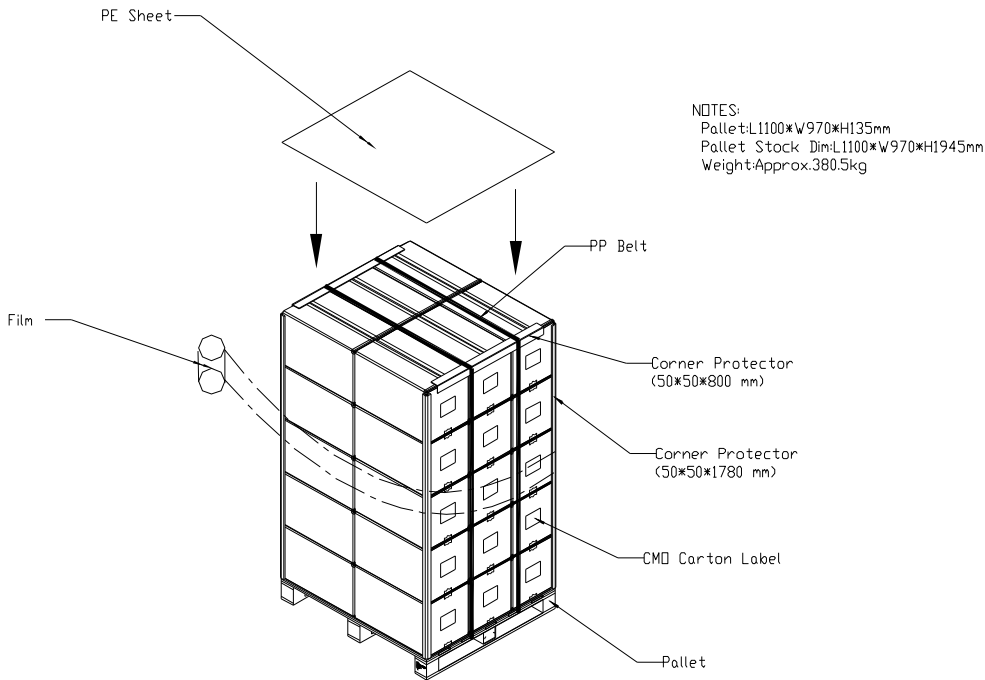

Figure. 8-2 Packing method

For air transport

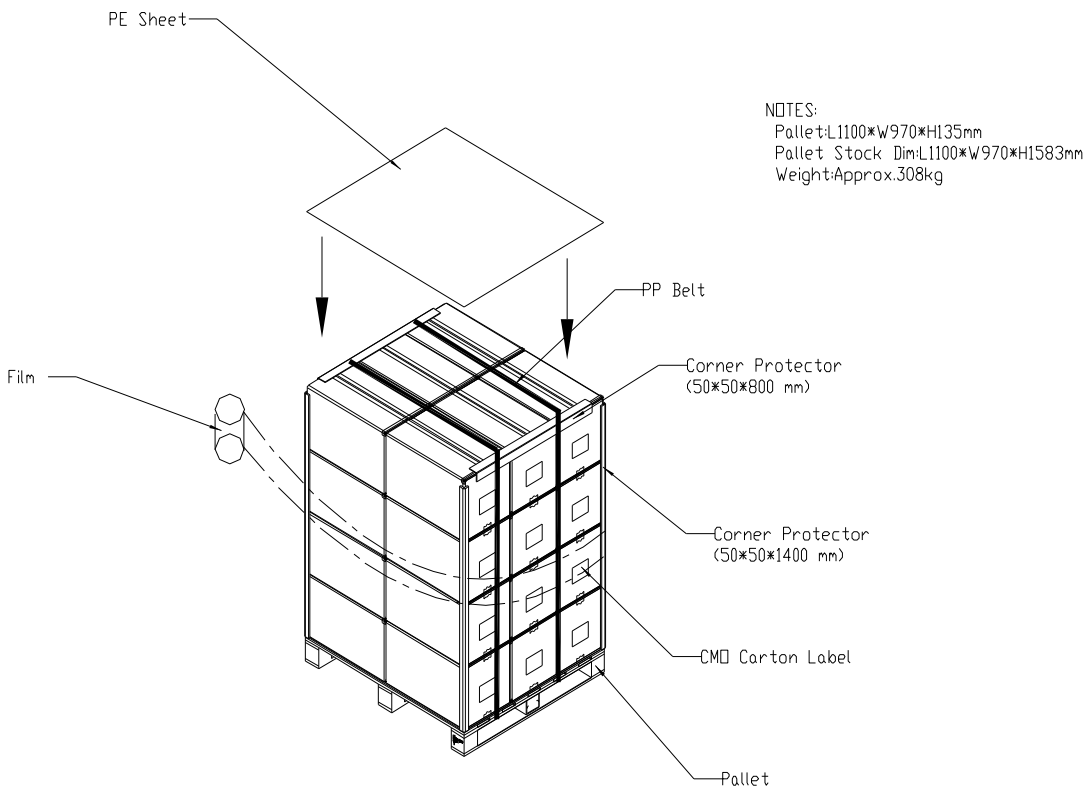
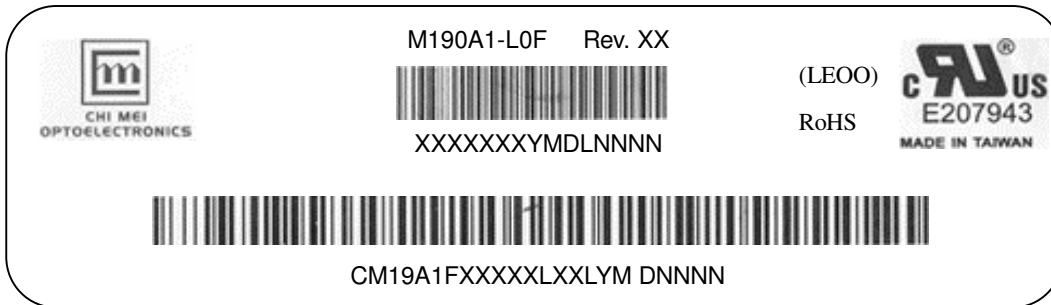

Figure. 8-3 Packing method

9. DEFINITION OF LABELS

9.1 CMO MODULE LABEL

The barcode nameplate is pasted on each module as illustration, and its definitions are as following explanation.



- (a) Model Name: M190A1-L0F
- (b) Revision: Rev. XX, for example: A0, A1... B1, B2... or C1, C2...etc.
- (c) CMO barcode definition:

Serial ID: XX-XX-X-XX-YMD-L-NNNN

| Code | Meaning | Description |
|------|------------------|---|
| XX | CMO internal use | - |
| XX | Revision | Cover all the change |
| X | CMO internal use | - |
| YMD | Year, month, day | Year: 2001=1, 2002=2, 2003=3, 2004=4... Month: 1~12=1, 2, 3, ~, 9, A, B, C Day: 1~31=1, 2, 3, ~, 9, A, B, C, ~, W, X, Y, exclude I, O, and U. |
| L | Product line # | Line 1=1, Line 2=2, Line 3=3, ... |
| NNNN | Serial number | Manufacturing sequence of product |

- (d) Customer's barcode definition:

Serial ID: CM-19A1F-X-X-X-XX-L-XX-L-YMD-NNNN

| Code | Meaning | Description |
|-------|-----------------------|---|
| CM | Supplier code | CMO=CM |
| 19A1F | Model number | M190A1-L0F=19A1F |
| X | Revision code | Non ZBD: 1,2,~,8,9 / ZBD: A~Z |
| X | Source driver IC code | Century=1, CLL=2, Demos=3, Epson=4, Fujitsu=5, Himax=6, Hitachi=7, Hynix=8, LDI=9, Matsushita=A, NEC=B, Novatec=C, OKI=D, Philips=E, Renasas=F, Samsung=G, Sanyo=H, Sharp=I, TI=J, Topro=K, Toshiba=L, Windbond=M |
| X | Gate driver IC code | |
| XX | Cell location | Tainan, Taiwan=TN |
| L | Cell line # | 1,2,~,9,A,B,~,Y,Z |
| XX | Module location | Tainan, Taiwan=TN ; Ningbo China=NP |
| L | Module line # | 1,2,~,9,A,B,~,Y,Z |
| YMD | Year, month, day | Year: 2001=1, 2002=2, 2003=3, 2004=4... Month: 1~12=1, 2, 3, ~, 9, A, B, C Day: 1~31= 1, 2, 3, ~, 9, A, B, C, ~, T, U, V |
| NNNN | Serial number | Manufacturing sequence of product |

(e) FAB ID(UL Factory ID):

| Region | Factory ID |
|--------|------------|
| TWCMO | GEMN |
| NBCMO | LEOO |
| NBCME | CANO |
| NHCMO | CAPG |

10. PRECAUTIONS

10.1 ASSEMBLY AND HANDLING PRECAUTIONS

- (1) Do not apply rough force such as bending or twisting to the module during assembly.
- (2) To assemble or install module into user's system can be only in clean working areas. The dust and oil may cause electrical short or worsen the polarizer.
- (3) It's not permitted to have pressure or impulse on the module because the LCD panel and Backlight will be damaged.
- (4) Always follow the correct power sequence when LCD module is connecting and operating. This can prevent damage to the CMOS LSI chips during latch-up.
- (5) Do not pull the I/F connector in or out while the module is operating.
- (6) Do not disassemble the module.
- (7) Use a soft dry cloth without chemicals for cleaning, because the surface of polarizer is very soft and easily scratched.
- (8) It is dangerous that moisture come into or contacted the LCD module, because moisture may damage LCD module when it is operating.
- (9) High temperature or humidity may reduce the performance of module. Please store LCD module within the specified storage conditions.
- (10) When ambient temperature is lower than 10°C may reduce the display quality. For example, the response time will become slowly, and the starting voltage of CCFL will be higher than room temperature.

10.2 SAFETY PRECAUTIONS

- (1) The startup voltage of Backlight is approximately 1000 Volts. It may cause electrical shock while assembling with inverter. Do not disassemble the module or insert anything into the Backlight unit.
- (2) If the liquid crystal material leaks from the panel, it should be kept away from the eyes or mouth. In case of contact with hands, skin or clothes, it has to be washed away thoroughly with soap.
- (3) After the module's end of life, it is not harmful in case of normal operation and storage.

10.3 OTHER

When fixed patterns are displayed for a long time ,remnant image is likely to occur.

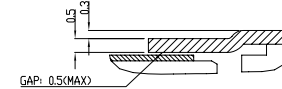
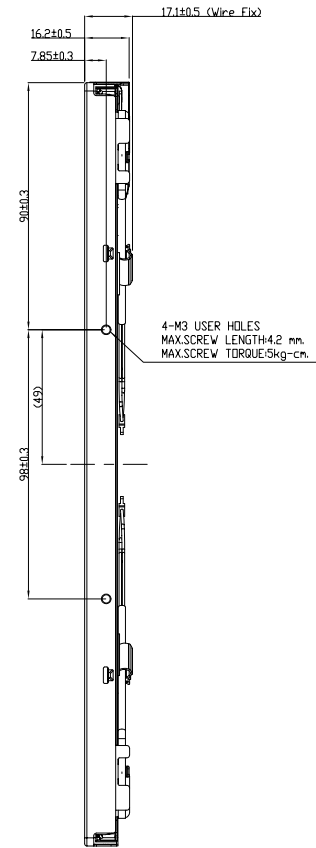
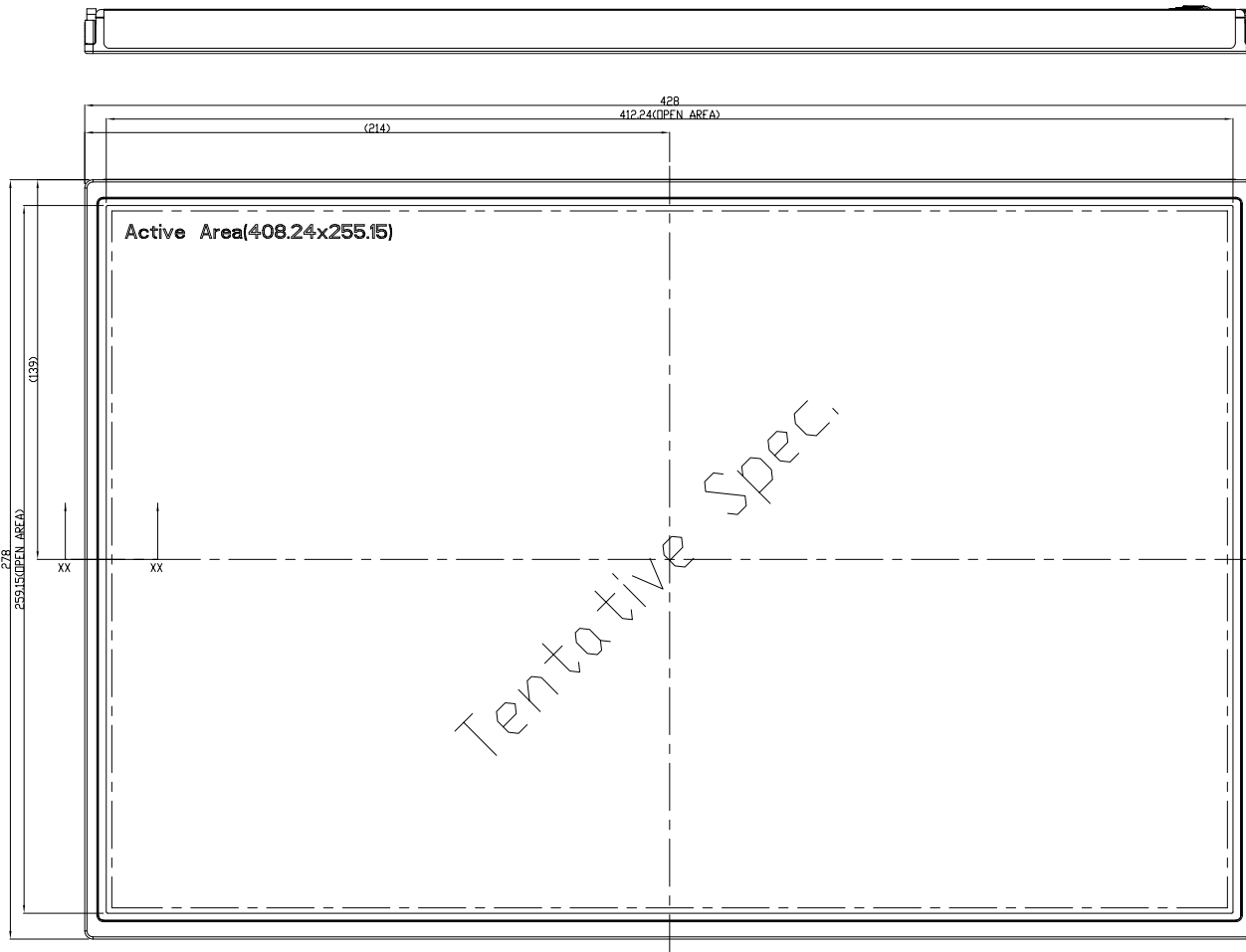
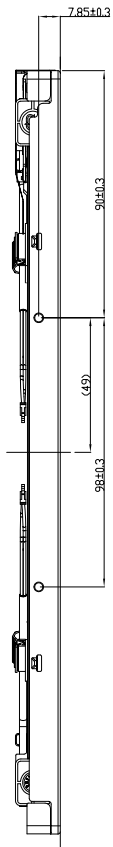

SECTION XX-XX
SCALE 10:1

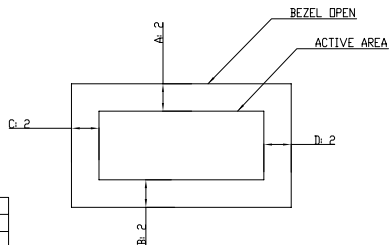

NOTES:
 1. UNSPECIFIED TOLERANCE: ±0.5mm.
 2. * MARKS THE DESIGN CRITICAL DIMENSION.
 3. * @ MARKS THE PROCESS CRITICAL DIMENSION.
 4. I/F CONNECTOR SPEC: STM-M5AKT2407P304A or STARCONN-093G30-B0001A.
 5. LAMP CONNECTOR SPEC: YEDNHD 3500HS-02L OR EQUIVALENT.
 6. Tilt and portion disposition tolerance of display area are as following
 (1) Y-direction : IA-BI <= 1mm
 (2) X-direction : IC-DI <= 1mm

| | | | |
|-------------------------------|--|--|---|
| TITLE ASSY_MODULE_M190M_LOF | | | 2D REV: 01 |
| Approved YULE LIN | | | Drawing No. M190H1011 |
| Checked TAURUS HSIEH | | | Part No. TBD |
| Drawer BENWEI HUANG | | | Material TBD |
| Designer TAURUS HSIEH | | | Date 01-Sep-2008 Scale 1:1 Unit mm |
| CHI MEI OPTOELECTRONICS CORP. | | | ALL RIGHTS RESERVED, COPYING FORBIDDEN. |

| Mark | Description | Date | Changed_By | Approved_By | ECN No. | Remark |
|------|-------------|------|------------|-------------|---------|--------|
| | | | | | | |
| | | | | | | |

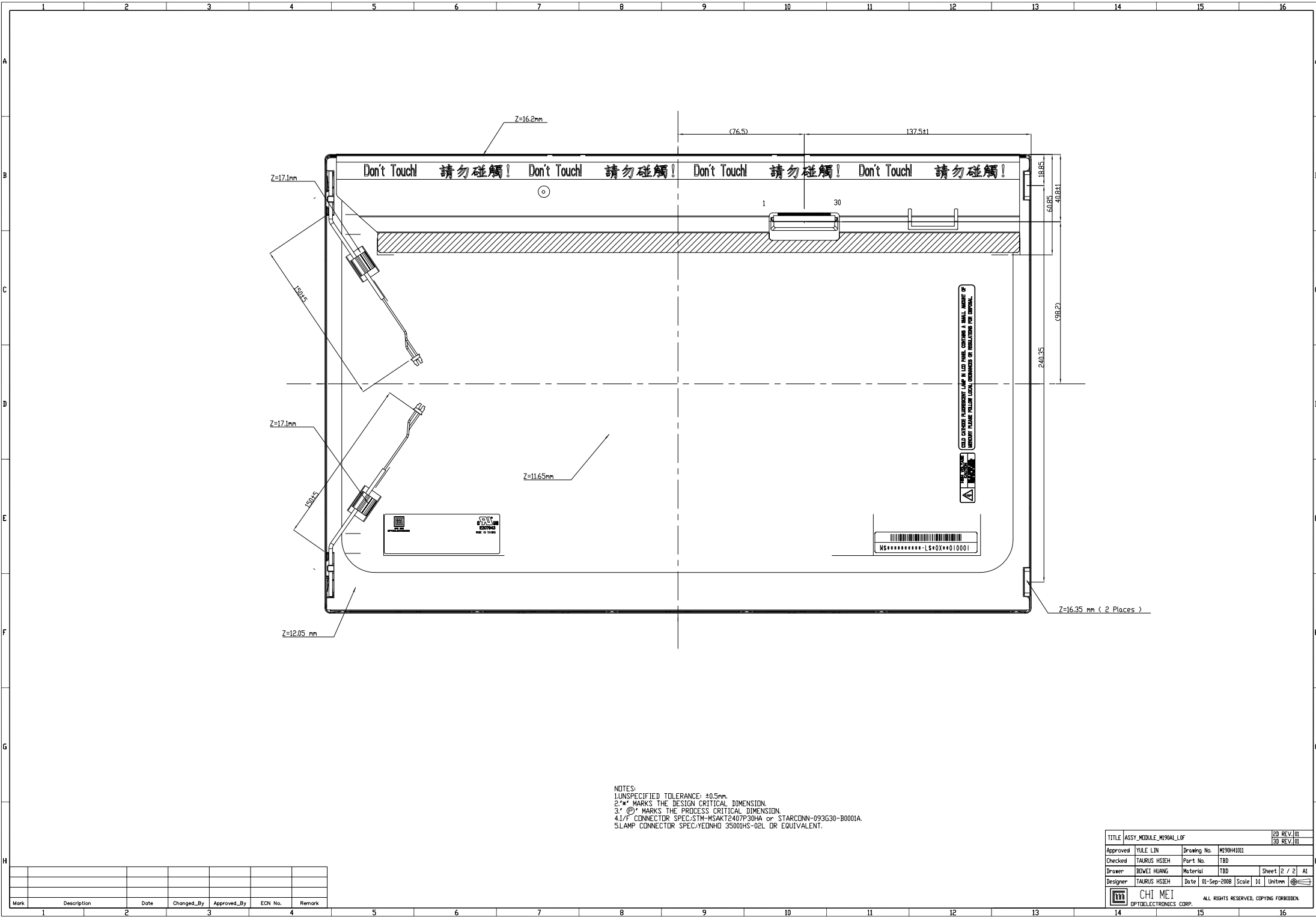

| Mark | Description | Date | Changed_By | Approved_By | ECN No. | Remark |
|------|-------------|------|------------|-------------|---------|--------|
| | | | | | | |
| | | | | | | |

| | | | |
|-----------------------------|--------------|---|-------------|
| TITLE ASSY_MODULE_M190M_LOF | | | 2D REV: 01 |
| | | | 3D REV: 01 |
| Approved | YULE LIN | Drawing No. | M190H1011 |
| Checked | TAURUS HSIEH | Part No. | TBD |
| Drawer | BEIWEI HUANG | Material | TBD |
| Designer | TAURUS HSIEH | Date | 01-Sep-2008 |
| | | Scale | 1:1 |
| | | Unit/mm | mm |
| | | ALL RIGHTS RESERVED, COPYING FORBIDDEN. | |