

TFT LCD Approval Specification

MODEL NO.: N101N6-L02

Customer : _____

Approved by : _____

Note :

| 記錄 | 工作 | 審核 | 角色 | 投票 |
|----------------------------|----------------------|-------------------------------------|----------|--------|
| 2008-12-12 16:16:43 CST | PMMD III Director | annie_hsu(徐凡 琇/56522 / 54873) | Director | Accept |

CONTENTS

| | |
|---|---------|
| REVISION HISTORY | -----3 |
| 1. GENERAL DESCRIPTION | -----4 |
| 1.1 OVERVIEW | |
| 1.2 FEATURES | |
| 1.3 APPLICATION | |
| 1.4 GENERAL SPECIFICATIONS | |
| 1.5 MECHANICAL SPECIFICATIONS | |
| 2. ABSOLUTE MAXIMUM RATINGS | -----5 |
| 2.1 ABSOLUTE RATINGS OF ENVIRONMENT | |
| 2.2 ELECTRICAL ABSOLUTE RATINGS | |
| 2.2.1 TFT LCD MODULE | |
| 2.2.2 BACKLIGHT UNIT | |
| 3. ELECTRICAL CHARACTERISTICS | -----7 |
| 3.1 TFT LCD MODULE | |
| 3.2 BACKLIGHT UNIT | |
| 4. BLOCK DIAGRAM | -----11 |
| 4.1 TFT LCD MODULE | |
| 5. INPUT TERMINAL PIN ASSIGNMENT | -----12 |
| 5.1 TFT LCD MODULE | |
| 5.2 TIMING DIAGRAM OF LVDS INPUT SIGNAL | |
| 5.3 COLOR DATA INPUT ASSIGNMENT | |
| 5.4 EDID DATA STRUCTURE | |
| 6. CONVERTER SPECIFICATION | -----18 |
| 6.1 ABSOLUTE MAXIMUM RATINGS | |
| 6.2 RECOMMENDED OPERATING RATINGS | |
| 6.3 LED BACKLIGHT CONTROL ON/OFF SEQUENCE | |
| 7. INTERFACE TIMING | -----19 |
| 7.1 INPUT SIGNAL TIMING SPECIFICATIONS | |
| 7.2 POWER ON/OFF SEQUENCE | |
| 8. OPTICAL CHARACTERISTICS | -----21 |
| 8.1 TEST CONDITIONS | |
| 8.2 OPTICAL SPECIFICATIONS | |
| 9. PRECAUTIONS | -----24 |
| 9.1 SYSTEM MATCHING PRECAUTIONS | |
| 9.2 HANDLING PRECAUTIONS | |
| 9.3 STORAGE PRECAUTIONS | |
| 9.4 OPERATION PRECAUTIONS | |
| 9.5 OTHER PRECAUTIONS | |
| 10. PACKING | -----25 |
| 10.1 CARTON | |
| 10.2 PALLET | |
| 11. DEFINITION OF LABELS | -----27 |
| 11.1 CMO MODULE LABEL | |
| 11.2 CARTON LABEL | |

REVISION HISTORY

| Version | Date | Page (New) | Section | Description |
|----------------|---------------|-------------------|----------------|--------------------------------------|
| Ver 2.0 | Nov. 26, 2008 | All All | | Approval specification first issued. |

1. GENERAL DESCRIPTION

1.1 OVERVIEW

N101N6-L02 is a 10.1" TFT Liquid Crystal Display module with LED Backlight unit and 40 pins LVDS interface. This module supports 1024 x 576 Wide-SVGA mode and can display 262,144 colors. The optimum viewing angle is at 6 o'clock direction. The converter module for Backlight is built in.

1.2 FEATURES

- WSVGA (1024 x 576 pixels) resolution
- 3.3V LVDS (Low Voltage Differential Signaling) interface with 1 pixel/clock
- Build in LED Converter

1.3 APPLICATION

- TFT LCD Notebook

1.4 GENERAL SPECIFICATIONS

| Item S | Specification | Unit | Note |
|--------------------|--|-------|------|
| Active Area | 222.72 (H) x 125.28 (V) (10.06 " diagonal) | mm | (1) |
| Bezel Opening Area | 226.34 (H) x 128.1 (V) | mm | |
| Driver Element | a-si TFT active matrix | - | - |
| Pixel Number | 1024 x R.G.B. x 576 | pixel | - |
| Pixel Pitch | 0.2175 (H) x 0.2175 (V) | mm | - |
| Pixel Arrangement | RGB vertical stripe | - | - |
| Display Colors | 262,144 | color | - |
| Transmissive Mode | Normally white | - | - |
| Surface Treatment | Hard coating (3H), Glare | - | - |

1.5 MECHANICAL SPECIFICATIONS

| Item | Min. | Typ. | Max. | Unit | Note |
|-------------|---------------------|-------|-------|------|------|
| Module Size | Horizontal(H) 234.5 | 235.0 | 235.5 | mm | (1) |
| | Vertical(V) 142.5 | 143.0 | 143.5 | mm | |
| | Thickness(T) - | 4.9 | 5.2 | mm | |
| Weight - | | 180 | 190 | g | |

Note (1) Please refer to the attached drawings for more information of front and back outline dimensions.

2. ABSOLUTE MAXIMUM RATINGS

2.1 ABSOLUTE RATINGS OF ENVIRONMENT

| Item Symbol | | Value | | Unit | Note |
|-------------------------------|--------------|-------|-------|------|----------|
| | | Min. | Max. | | |
| Storage Temperature | $T_{ST} -20$ | | +60 | °C | (1) |
| Operating Ambient Temperature | $T_{OP} 0$ | | +50 | °C | (1), (2) |
| Shock (Non-Operating) | $S_{NOP} -$ | | 220/2 | G/ms | (3), (5) |
| Vibration (Non-Operating) | $V_{NOP} -$ | | 1.5 | G | (4), (5) |

Note (1) Temperature and relative humidity range is shown in the figure below.

(a) 90 %RH Max. ($T_a \leq 40$ °C).

(b) Wet-bulb temperature should be 39 °C Max. ($T_a > 40$ °C).

(c) No condensation.

Note (2) The temperature of panel surface area should be 0 °C min. and 60 °C max.

Relative Humidity (%RH)

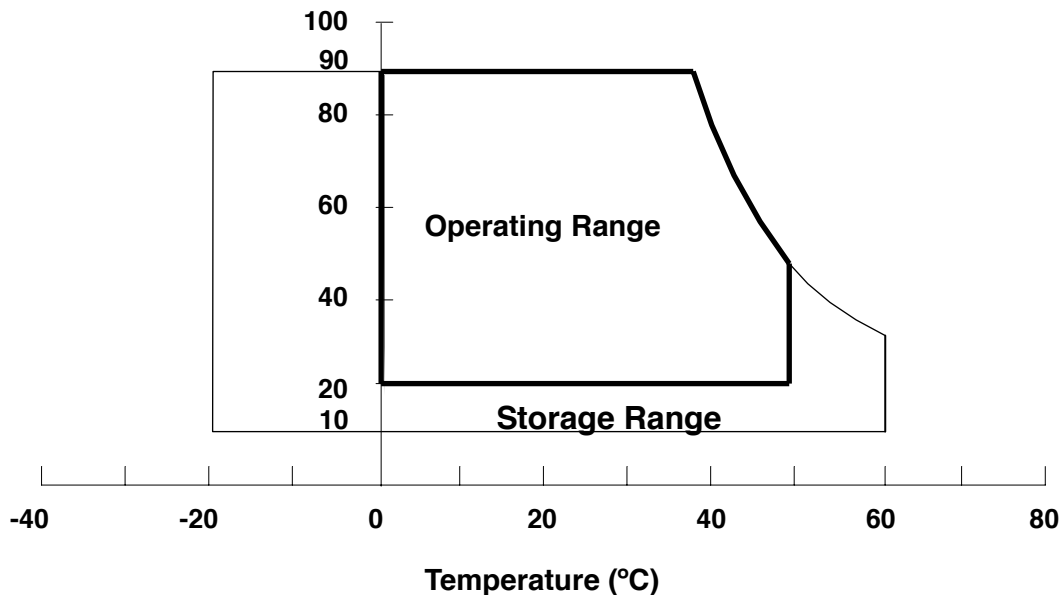

Note (3) 1 time for $\pm X, \pm Y, \pm Z$. for Condition (220G / 2ms) is half Sine Wave,.

Note (4) 10~500 Hz, 30 min/cycle, 1cycle for X,Y,Z-axis.

Note (5) At testing Vibration and Shock, the fixture in holding the module has to be hard and rigid enough so that the module would not be twisted or bent by the fixture.

The fixing condition is shown as below:

At Room Temperature

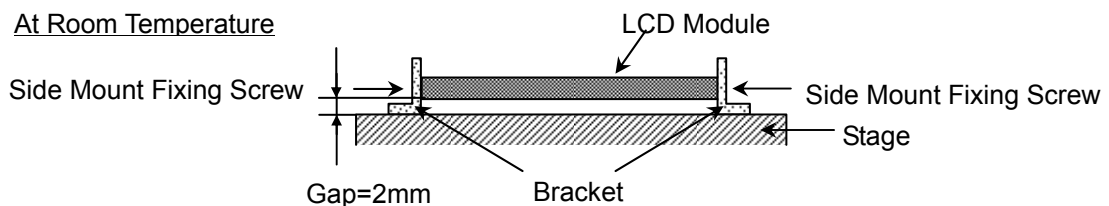

2.2 ELECTRICAL ABSOLUTE RATINGS

2.2.1 TFT LCD MODULE

| Item Symbol | | Value | | Unit | Note |
|----------------------|----------------|-------|------------------|------|------|
| | | Min. | Max. | | |
| Power Supply Voltage | $V_{CC} - 0.3$ | | +4.0 | V | (1) |
| Logic Input Voltage | $V_{IN} - 0.3$ | | $V_{CC} + 0.3$ V | | |

Note (1) Permanent damage to the device may occur if maximum values are exceeded. Function operation should be restricted to the conditions described under Normal Operating Conditions.

2.2.2 BACKLIGHT UNIT

| Item | Value | | Unit | Note |
|------------------------------------|-------|------|-----------|----------|
| | Min. | Max. | | |
| LED Light Bar Power Supply Voltage | -40 | 27.2 | V_{DC} | (1), (2) |
| LED Light Bar Power Supply Current | -- | 75 | mA_{DC} | |

Note (1) Permanent damage to the device may occur if maximum values are exceeded. Function operation should be restricted to the conditions described under Normal Operating Conditions.

Note (2) Specified values are for LED (Refer to Section 3.2 for further information).

3. ELECTRICAL CHARACTERISTICS

3.1 TFT LCD MODULE

Ta = 25 ± 2 °C

| Parameter Sy | mbol | Value | | | Unit | Note |
|--|-------------------------|-----------|-------|------|------|-------------------------------|
| | | Min. T | yp. | Max. | | |
| Power Supply Voltage | V _{CC} | 3.0 | 3.3 | 3.6 | V | - |
| Ripple Voltage | V _{RP} - | | 50 | | mV | - |
| Rush Current | I _{RUSH} - | | - | 1.5 | A | (2) |
| Initial Stage Current | I _{IS} - | | - | 1.0 | A | (2) |
| Power Supply Current | I _{CC} | | 180 | 210 | mA | (3)a |
| | | - 220 | | 250 | mA | (3)b |
| LVDS Differential Input High Threshold | V _{TH(LVDS)} | - - | | +100 | mV | (5), V _{CM} =1.2V |
| LVDS Differential Input Low Threshold | V _{TL(LVDS)} - | 0 0 | - | - | mV | (5) V _{CM} =1.2V |
| LVDS Common Mode Voltage | V _{CM} | 1.125 - | 1.375 | | V | (5) |
| LVDS Differential Input Voltage | V _{ID} | 100 - | 600 | | mV | (5) |
| Terminating Resistor | R _T - | | 100 | - | Ohm | - |
| Power per EBL WG | P _{EBL} | - 0.894 - | | | W | (4) |

Note (1) The ambient temperature is Ta = 25 ± 2 °C.

Note (2) I_{RUSH}: the maximum current when VCC is rising

I_{IS}: the maximum current of the first 100ms after power-on

Measurement Conditions: Shown as the following figure. Test pattern: black.

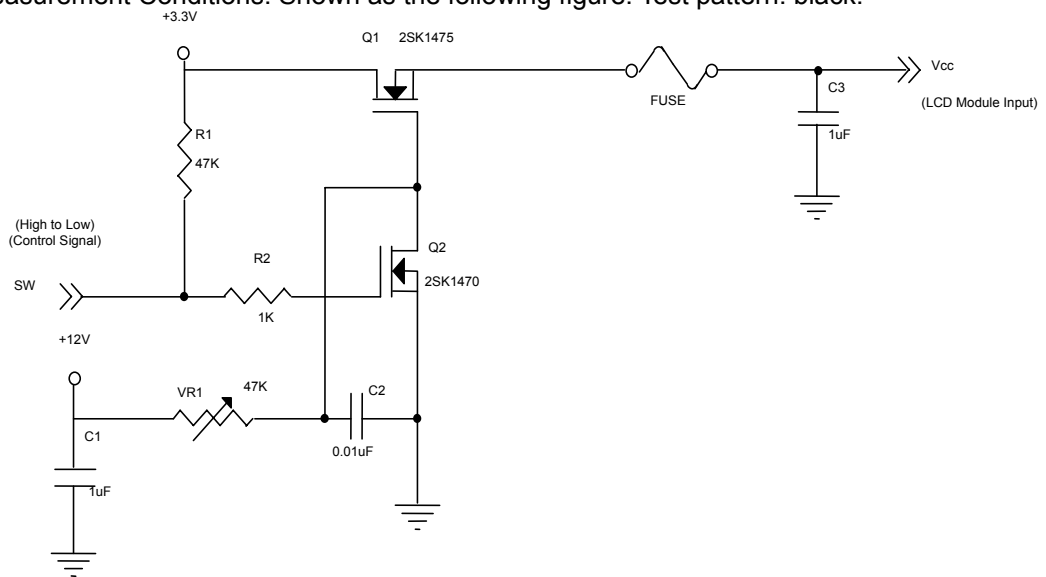

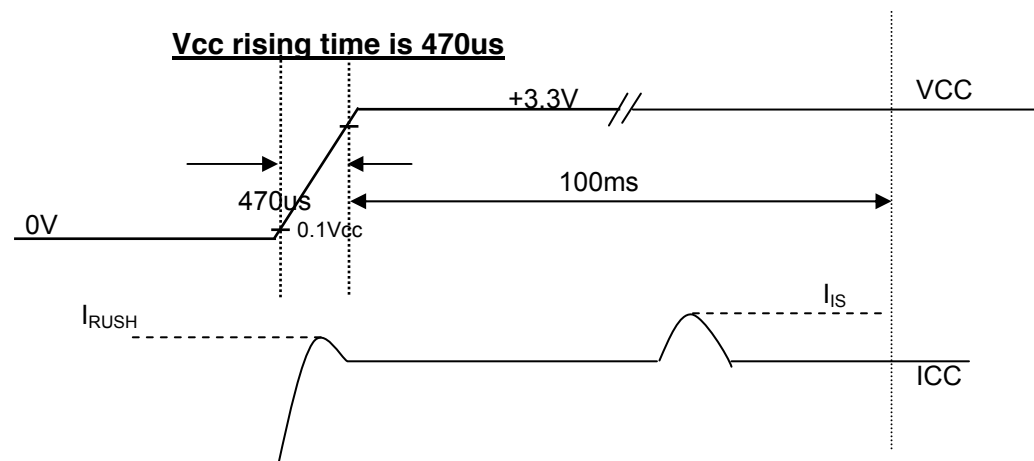

Note (3) The specified power supply current i_s under the conditions at $V_{cc} = 3.3\text{ V}$, $T_a = 25 \pm 2^\circ\text{C}$, DC Current and $f_v = 60\text{ Hz}$, whereas a power dissipation check pattern below is displayed.

a. White Pattern



Active Area

b. Black Pattern

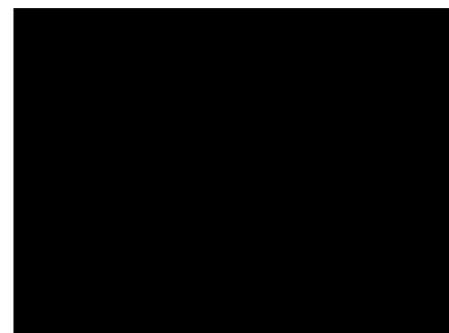

Active Area

Note (4) The specified power are the sum of LCD panel electronics input power and the inverter input power. Test conditions are as follows.

- (a) $V_{cc} = 3.3\text{ V}$, $T_a = 25 \pm 2^\circ\text{C}$, $f_v = 60\text{ Hz}$,
- (b) The pattern used is a black and white 32 x 36 checkerboard, slide #100 from the VESA file "Flat Panel Display Monitor Setup Patterns", FPDMSU.ppt.
- (c) Luminance: 60 nits.

Note (5) The parameters of LVDS signals are defined as the following figures.

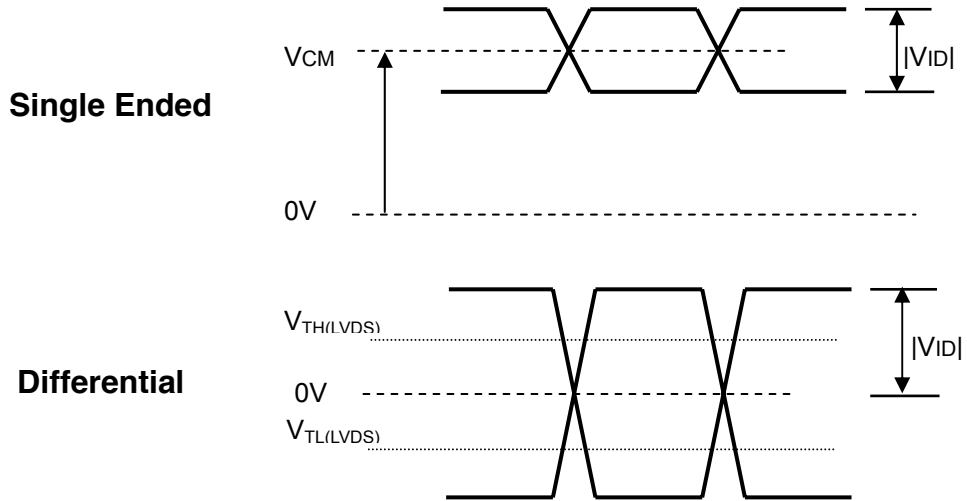

3.2 BACKLIGHT UNIT

Ta = 25 ± 2 °C

| Parameter Symbol | | Value | | | Unit | Note |
|------------------------------------|-----------------|--------|------|------|------|-----------------|
| | | Min. T | yp. | Max. | | |
| LED Light Bar Power Supply Voltage | Vo | 23.2 | 25.6 | 27.2 | V | (1) (Duty 100%) |
| LED Light Bar Power Supply Current | Io | 45 | 51 | 60 | mA | |
| Power Consumption | Po | 1.18 | 1.31 | 1.39 | W | (2)(@Io=51mA) |
| LED Life Time | L _{BL} | 1500 | 0 | - | - | Hrs (3) |

Note (1) LED current is measured by utilizing a high frequency current meter as shown below :

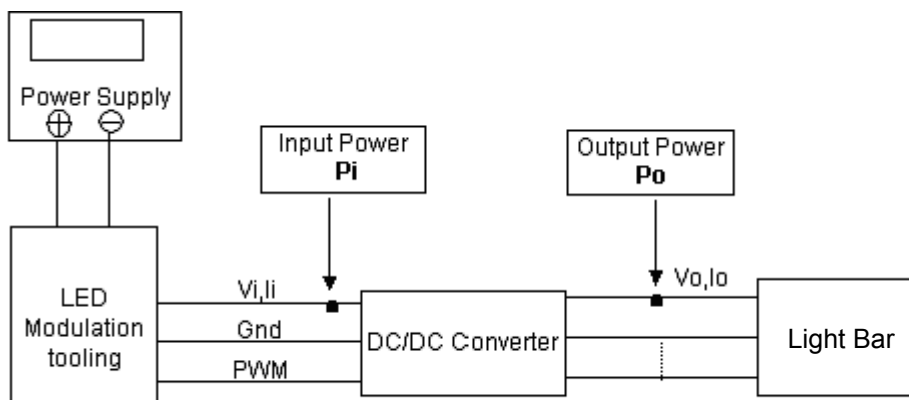

Note (2) $P_o = I_o \times V_o$

Note (3) The lifetime of LED is defined as the time when it continues to operate under the conditions at Ta = 25 ± 2 °C and I = 17 mA(Per EA) until the brightness becomes ≤ 50% of its original value.

4. BLOCK DIAGRAM

4.1 TFT LCD MODULE

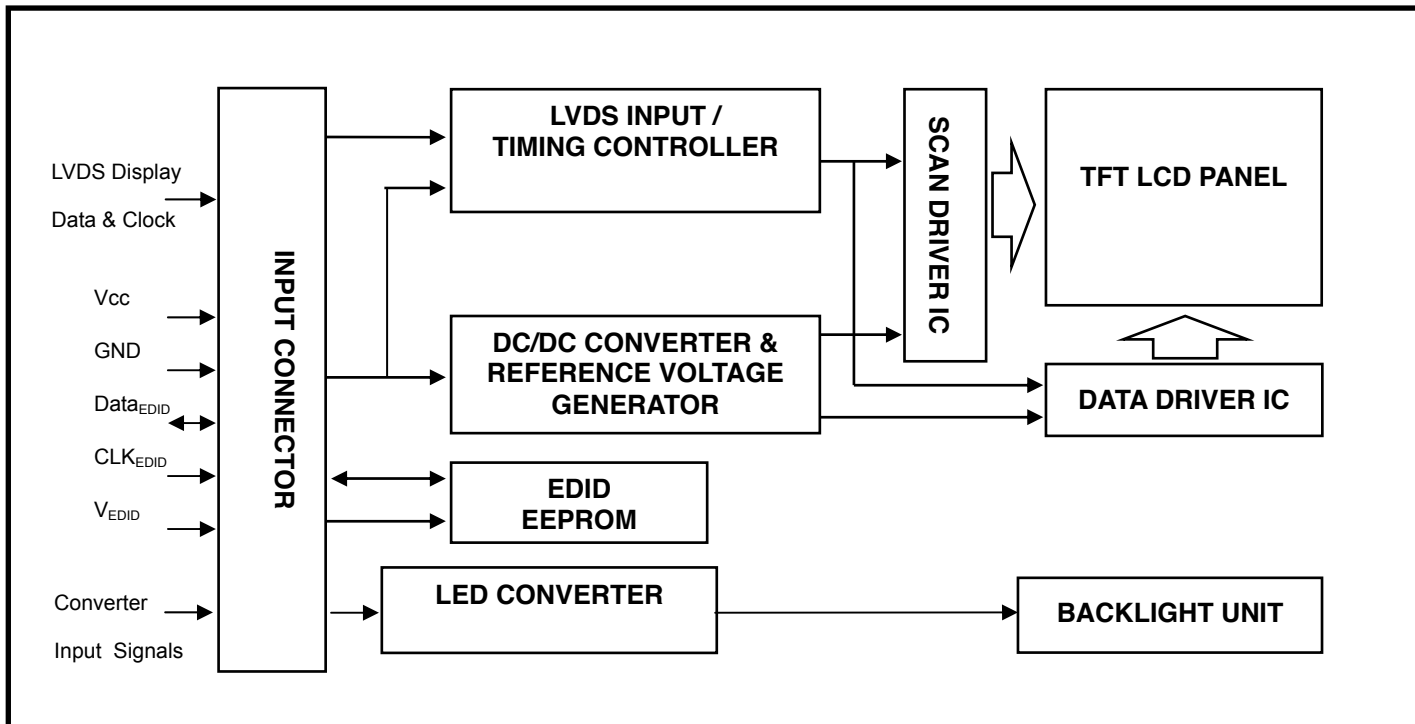

5. INPUT TERMINAL PIN ASSIGNMENT

5.1 TFT LCD MODULE

| Pin | Symbol | Description | Polarity | Remark |
|-----|----------|--------------------------------------|----------|-----------------|
| 1 | NC | No Connection (Reserve) | | |
| 2 | VDD | Power Supply (3.3V typ.) | | |
| 3 | VDD | Power Supply (3.3V typ.) | | |
| 4 | VEDID | DDC 3.3V power | | |
| 5 | NC | No Connection (Reserve for CMO test) | | |
| 6 | CLKEDID | DDC clock | | |
| 7 | DATAEDID | DDC data | | |
| 8 | Rxin0- | LVDS differential data input | Negative | R0-R5, G0 |
| 9 | Rxin0+ | LVDS differential data input | Positive | |
| 10 | VSS | Ground | | |
| 11 | Rxin1- | LVDS differential data input | Negative | G1~G5, B0, B1 |
| 12 | Rxin1+ | LVDS differential data input | Positive | |
| 13 | VSS | Ground | | |
| 14 | Rxin2- | LVDS Differential Data Input | Negative | B2-B5,HS,VS, DE |
| 15 | Rxin2+ | LVDS Differential Data Input | Positive | |
| 16 | VSS | Ground | | |
| 17 | RxCLK- | LVDS differential clock input | | |
| 18 | RxCLK+ | LVDS differential clock input | | |
| 19 | VSS | Ground | | |
| 20 | NC | No Connection (Reserve) | | |
| 21 | NC | No Connection (Reserve) | | |
| 22 | VSS | Ground | | |
| 23 | NC | No Connection (Reserve) | | |
| 24 | NC | No Connection (Reserve) | | |
| 25 | VSS | Ground | | |
| 26 | NC | No Connection (Reserve) | | |
| 27 | NC | No Connection (Reserve) | | |
| 28 | VSS | Ground | | |
| 29 | NC | No Connection (Reserve) | | |
| 30 | NC | No Connection (Reserve) | | |
| 31 | VSS | LED Ground | | |
| 32 | VSS | LED Ground | | |
| 33 | VSS | LED Ground | | |
| 34 | NC | No Connection (Reserve) | | |
| 35 | PWM | LED BLU Brightness Control | | |
| 36 | LED_EN | LED Converter Enable | | |
| 37 | NC | No Connection (Reserve) | | |
| 38 | VLED | LED Converter Input Power (5~20V) | | |
| 39 | VLED | LED Converter Input Power (5~20V) | | |
| 40 | VLED | LED Converter Input Power (5~20V) | | |

Note (1) Connector Part No.: IPEX-20455-040E-12 or equivalent

Note (2) User's connector Part No: IPEX-20453-040T-01 or equivalent

Note (3) The first pixel is odd as shown in the following figure.

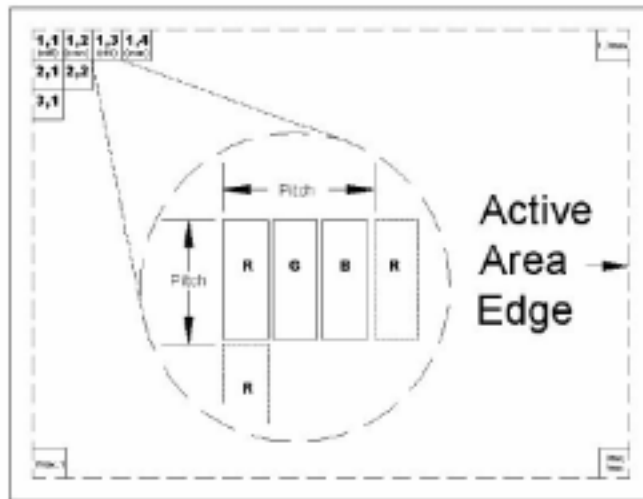

5.2 TIMING DIAGRAM OF LVDS INPUT SIGNAL

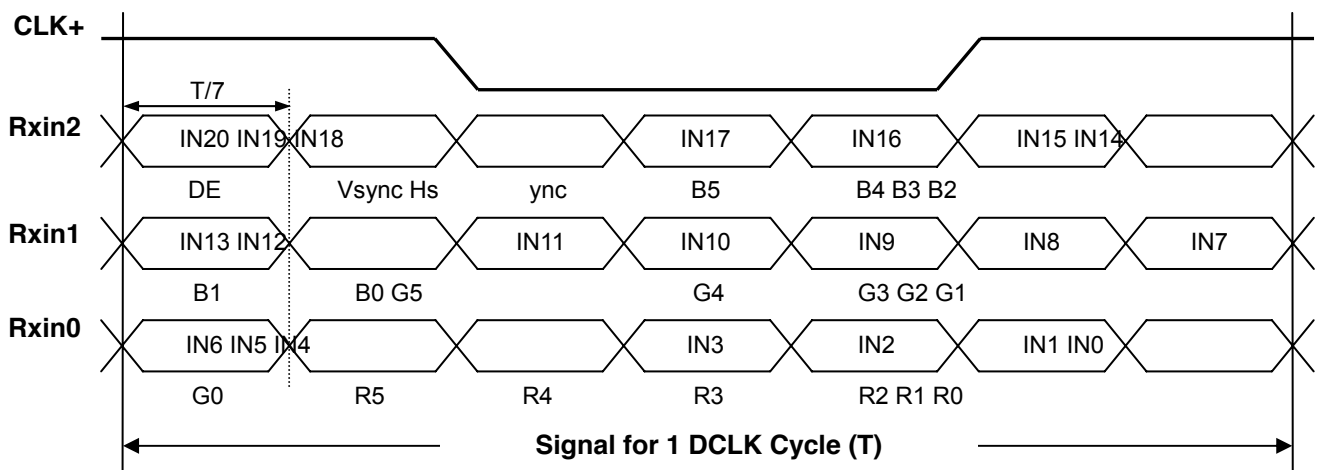

5.3 COLOR DATA INPUT ASSIGNMENT

The brightness of each primary color (red, green and blue) is based on the 6-bit gray scale data input for the color. The higher the binary input the brighter the color. The table below provides the assignment of color versus data input.

| Color | | Data Signal | | | | | | | | | | | | | | | | | |
|---------------------|---------------|-------------|----|----|----|----|----|----|----|----|----|----|----|------|----|----|----|----|----|
| | | Red Green | | | | | | en | | | | | | Blue | | | | | |
| | | R5 | R4 | R3 | R2 | R1 | R0 | G5 | G4 | G3 | G2 | G1 | G0 | B5 | B4 | B3 | B2 | B1 | B0 |
| Basic Colors | Black | 0 | 0 | 0 | 0 | 0 | 0 | 0 | 0 | 0 | 0 | 0 | 0 | 0 | 0 | 0 | 0 | 0 | 0 |
| | Red | 1 | 1 | 1 | 1 | 1 | 1 | 0 | 0 | 0 | 0 | 0 | 0 | 0 | 0 | 0 | 0 | 0 | 0 |
| | Green | 0 | 0 | 0 | 0 | 0 | 0 | 1 | 1 | 1 | 1 | 1 | 1 | 0 | 0 | 0 | 0 | 0 | 0 |
| | Blue | 0 | 0 | 0 | 0 | 0 | 0 | 0 | 0 | 0 | 0 | 0 | 0 | 1 | 1 | 1 | 1 | 1 | 1 |
| | Cyan | 0 | 0 | 0 | 0 | 0 | 0 | 1 | 1 | 1 | 1 | 1 | 1 | 1 | 1 | 1 | 1 | 1 | 1 |
| | Magenta | 1 | 1 | 1 | 1 | 1 | 1 | 0 | 0 | 0 | 0 | 0 | 0 | 0 | 1 | 1 | 1 | 1 | 1 |
| | Yellow | 1 | 1 | 1 | 1 | 1 | 1 | 1 | 1 | 1 | 1 | 1 | 1 | 0 | 0 | 0 | 0 | 0 | 0 |
| | White | 1 | 1 | 1 | 1 | 1 | 1 | 1 | 1 | 1 | 1 | 1 | 1 | 1 | 1 | 1 | 1 | 1 | 1 |
| Gray Scale Of Red | Red(0)/Dark | 0 | 0 | 0 | 0 | 0 | 0 | 0 | 0 | 0 | 0 | 0 | 0 | 0 | 0 | 0 | 0 | 0 | 0 |
| | Red(1) | 0 | 0 | 0 | 0 | 0 | 1 | 0 | 0 | 0 | 0 | 0 | 0 | 0 | 0 | 0 | 0 | 0 | 0 |
| | Red(2) | 0 | 0 | 0 | 0 | 1 | 0 | 0 | 0 | 0 | 0 | 0 | 0 | 0 | 0 | 0 | 0 | 0 | 0 |
| | : | : | : | : | : | : | : | : | : | : | : | : | : | : | : | : | : | : | : |
| | : | : | : | : | : | : | : | : | : | : | : | : | : | : | : | : | : | : | : |
| | : | : | : | : | : | : | : | : | : | : | : | : | : | : | : | : | : | : | : |
| | Red(61) | 1 | 1 | 1 | 1 | 0 | 1 | 0 | 0 | 0 | 0 | 0 | 0 | 0 | 0 | 0 | 0 | 0 | 0 |
| | Red(62) | 1 | 1 | 1 | 1 | 1 | 0 | 0 | 0 | 0 | 0 | 0 | 0 | 0 | 0 | 0 | 0 | 0 | 0 |
| Red(63) | 1 | 1 | 1 | 1 | 1 | 1 | 0 | 0 | 0 | 0 | 0 | 0 | 0 | 0 | 0 | 0 | 0 | 0 | |
| Gray Scale Of Green | Green(0)/Dark | 0 | 0 | 0 | 0 | 0 | 0 | 0 | 0 | 0 | 0 | 0 | 0 | 0 | 0 | 0 | 0 | 0 | 0 |
| | Green(1) | 0 | 0 | 0 | 0 | 0 | 0 | 0 | 0 | 0 | 0 | 0 | 1 | 0 | 0 | 0 | 0 | 0 | 0 |
| | Green(2) | 0 | 0 | 0 | 0 | 0 | 0 | 0 | 0 | 0 | 0 | 1 | 0 | 0 | 0 | 0 | 0 | 0 | 0 |
| | : | : | : | : | : | : | : | : | : | : | : | : | : | : | : | : | : | : | : |
| | : | : | : | : | : | : | : | : | : | : | : | : | : | : | : | : | : | : | : |
| | : | : | : | : | : | : | : | : | : | : | : | : | : | : | : | : | : | : | : |
| | Green(61) | 0 | 0 | 0 | 0 | 0 | 0 | 1 | 1 | 1 | 1 | 0 | 1 | 0 | 0 | 0 | 0 | 0 | 0 |
| | Green(62) | 0 | 0 | 0 | 0 | 0 | 0 | 1 | 1 | 1 | 1 | 1 | 0 | 0 | 0 | 0 | 0 | 0 | 0 |
| Green(63) | 0 | 0 | 0 | 0 | 0 | 0 | 1 | 1 | 1 | 1 | 1 | 1 | 0 | 0 | 0 | 0 | 0 | 0 | |
| Gray Scale Of Blue | Blue(0)/Dark | 0 | 0 | 0 | 0 | 0 | 0 | 0 | 0 | 0 | 0 | 0 | 0 | 0 | 0 | 0 | 0 | 0 | 0 |
| | Blue(1) | 0 | 0 | 0 | 0 | 0 | 0 | 0 | 0 | 0 | 0 | 0 | 0 | 0 | 0 | 0 | 0 | 0 | 1 |
| | Blue(2) | 0 | 0 | 0 | 0 | 0 | 0 | 0 | 0 | 0 | 0 | 0 | 0 | 0 | 0 | 0 | 0 | 1 | 0 |
| | : | : | : | : | : | : | : | : | : | : | : | : | : | : | : | : | : | : | : |
| | : | : | : | : | : | : | : | : | : | : | : | : | : | : | : | : | : | : | : |
| | : | : | : | : | : | : | : | : | : | : | : | : | : | : | : | : | : | : | : |
| | Blue(61) | 0 | 0 | 0 | 0 | 0 | 0 | 0 | 0 | 0 | 0 | 0 | 0 | 1 | 1 | 1 | 1 | 0 | 1 |
| | Blue(62) | 0 | 0 | 0 | 0 | 0 | 0 | 0 | 0 | 0 | 0 | 0 | 0 | 1 | 1 | 1 | 1 | 1 | 0 |
| Blue(63) | 0 | 0 | 0 | 0 | 0 | 0 | 0 | 0 | 0 | 0 | 0 | 0 | 1 | 1 | 1 | 1 | 1 | 1 | |

Note (1) 0: Low Level Voltage, 1: High Level Voltage

5.4 EDID DATA STRUCTURE

The EDID (Extended Display Identification Data) data formats are to support displays as defined in the VESA Plug & Display and FPD1 standards.

| Byte # (decimal) | Byte # (hex) | Field Name and Comments | Value (hex) | Value (binary) |
|------------------|--------------|--|-------------|----------------|
| 0 | 0 H | eader | 00 00 | 00 0000 |
| 1 | 1 H | eader | FF 1 | 1111111 |
| 2 | 2 H | eader | FF 1 | 1111111 |
| 3 | 3 H | eader | FF 1 | 1111111 |
| 4 | 4 H | eader | FF 1 | 1111111 |
| 5 | 5 H | eader | FF 1 | 1111111 |
| 6 | 6 H | eader | FF 1 | 1111111 |
| 7 | 7 H | eader | 00 00 | 00 0000 |
| 8 | 8 | EISA ID manufacturer name ("CMO") | 0D 00 | 00 1101 |
| 9 | 9 | EISA ID manufacturer name (Compressed ASCII) | AF 10 | 10 1111 |
| 10 | 0A | ID product code (N101N6-L02) | 02 | 00000010 |
| 11 | 0B | ID product code (hex LSB first; N101N6-L02) | 10 | 00010000 |
| 12 | 0C | ID S/N (fixed "0") | 00 00 | 00 0000 |
| 13 | 0D | ID S/N (fixed "0") | 00 00 | 00 0000 |
| 14 | 0E | ID S/N (fixed "0") | 00 00 | 00 0000 |
| 15 | 0F | ID S/N (fixed "0") | 00 00 | 00 0000 |
| 16 | 10 | Week of manufacture (fixed week code) | 2C 00 | 10 1100 |
| 17 | 11 | Year of manufacture (fixed year code) | 12 00 | 01 0010 |
| 18 | 12 | EDID structure version # ("1") | 01 00 | 00 0001 |
| 19 | 13 | EDID revision # ("3") | 03 00 | 00 0011 |
| 20 | 14 | Video I/P definition ("digital") | 80 10 | 00 0000 |
| 21 | 15 | Max H image size ("22.272cm") | 16 00 | 01 0110 |
| 22 | 16 | Max V image size ("12.53cm") | 0C 00 | 00 1100 |
| 23 | 17 | Display Gamma (Gamma = "2.2") | 78 01 | 111000 |
| 24 | 18 | Feature support ("Active off, RGB Color") | 0A 00 | 00 1010 |
| 25 | 19 | Rx1, Rx0, Ry1, Ry0, Gx1, Gx0, Gy1, Gy0 | CF | 11001111 |
| 26 | 1A | Bx1, Bx0, By1, By0, Wx1, Wx0, Wy1, Wy0 | 45 | 01000101 |
| 27 | 1B | Rx=0.5 65 | 90 | 10010000 |
| 28 | 1C | Ry=0.3 48 | 59 | 01011001 |
| 29 | 1D | Gx=0.34 3 | 57 | 01010111 |
| 30 | 1E | Gy=0.58 5 | 95 | 10010101 |
| 31 | 1F | Bx=0.161 | 29 | 00101001 |
| 32 | 20 | By=0.121 | 1F | 00011111 |
| 33 | 21 | Wx=0.3 13 | 50 | 01010000 |
| 34 | 22 | Wy =0.329 | 54 | 01010100 |
| 35 | 23 | Established timings 1 | 00 00 | 00 0000 |
| 36 | 24 | Established timings 2 | 00 00 | 00 0000 |
| 37 | 25 | Manufacturer's reserved timings | 00 00 | 00 0000 |
| 38 | 26 | Standard timing ID # 1 | 01 00 | 00 0001 |
| 39 | 27 | Standard timing ID # 1 | 01 00 | 00 0001 |
| 40 | 28 | Standard timing ID # 2 | 01 | 00000001 |

| Byte # (decimal) | Byte # (hex) | Field Name and Comments | Value (hex) | Value (binary) |
|---------------------|-----------------|--|----------------|-------------------|
| 41 | 29 | Standard timing ID # 2 | 01 0000 | 0001 |
| 42 | 2A | Standard timing ID # 3 | 01 0000 | 0001 |
| 43 | 2B | Standard timing ID # 3 | 01 0000 | 0001 |
| 44 | 2C | Standard timing ID # 4 | 01 0000 | 0001 |
| 45 | 2D | Standard timing ID # 4 | 01 0000 | 0001 |
| 46 | 2E | Standard timing ID # 5 | 01 0000 | 0001 |
| 47 | 2F | Standard timing ID # 5 | 01 0000 | 0001 |
| 48 | 30 | Standard timing ID # 6 | 01 0000 | 0001 |
| 49 | 31 | Standard timing ID # 6 | 01 0000 | 0001 |
| 50 | 32 | Standard timing ID # 7 | 01 0000 | 0001 |
| 51 | 33 | Standard timing ID # 7 | 01 0000 | 0001 |
| 52 | 34 | Standard timing ID # 8 | 01 0000 | 0001 |
| 53 | 35 | Standard timing ID # 8 | 01 0000 | 0001 |
| 54 | 36 | Detailed timing description # 1 Pixel clock ("42.2MHz", According to VESA CVT Rev1.1) | 7C 01 | 111100 |
| 55 | 37 | # 1 Pixel clock (hex LSB first) | 10 0001 | 0000 |
| 56 | 38 | # 1 H active ("1024") | 00 0000 | 0000 |
| 57 | 39 | # 1 H blank ("160") | A0 1010 | 0000 |
| 58 | 3A | # 1 H active : H blank ("1024 : 160") | 40 0100 | 0000 |
| 59 | 3B | # 1 V active ("576") | 40 0100 | 0000 |
| 60 | 3C | # 1 V blank ("17") | 11 0001 | 0001 |
| 61 | 3D | # 1 V active : V blank ("576 : 17") | 20 0010 | 0000 |
| 62 | 3E | # 1 H sync offset ("48") | 30 001 | 10000 |
| 63 | 3F | # 1 H sync pulse width ("32") | 20 0010 | 0000 |
| 64 | 40 | # 1 V sync offset : V sync pulse width ("3 : 5") | 35 001 | 10101 |
| 65 41 | | # 1 H sync offset : H sync pulse width : V sync offset : V sync width ("48: 32 : 3 : 5") | 00 0000 | 0000 |
| 66 | 42 | # 1 H image size ("222.72 mm") | DE | 11011110 |
| 67 | 43 | # 1 V image size ("125.28 mm") | 7D | 01111101 |
| 68 | 44 | # 1 H image size : V image size ("303 : 190") | 00 0000 | 0000 |
| 69 | 45 | # 1 H boarder ("0") | 00 0000 | 0000 |
| 70 | 46 | # 1 V boarder ("0") | 00 0000 | 0000 |
| 71 47 | | # 1 Non-interlaced, Normal, no stereo, Separate sync, H/V pol Negatives | 18 000 | 11000 |
| 72 | 48 | Detailed timing description # 2 | 00 0000 | 0000 |
| 73 | 49 | # 2 Flag | 00 0000 | 0000 |
| 74 | 4A | # 2 Reserved | 00 0000 | 0000 |
| 75 4B | | # 2 FE (hex) defines ASCII string (Model Name "N101N6-L02", ASCII) | FE 1 | 1111110 |
| 76 | 4C | # 2 Flag | 00 0000 | 0000 |
| 77 | 4D | # 2 1st character of name ("N") | 4E 0100 | 1110 |
| 78 | 4E | # 2 2nd character of name ("1") | 31 001 | 10001 |
| 79 | 4F | # 2 3rd character of name ("0") | 30 001 | 10000 |
| 80 | 50 | # 2 4th character of name ("1") | 31 001 | 10001 |
| 81 | 51 | # 2 5th character of name ("N") | 4E 0100 | 1110 |
| 82 | 52 | # 2 6th character of name ("6") | 36 001 | 10110 |
| 83 | 53 | # 2 7th character of name ("-") | 2D 0010 | 1101 |

| Byte # (decimal) | Byte # (hex) | Field Name and Comments | Value (hex) | Value (binary) |
|---------------------|-----------------|--|----------------|-------------------|
| 84 | 54 | # 2 8th character of name ("L") | 4C 01 | 00 1100 |
| 85 | 55 | # 2 9th character of name ("0") | 30 00 | 1 10000 |
| 86 | 56 | # 2 9th character of name ("2") | 32 00 | 1 10010 |
| 87 | 57 | # 2 New line character indicates end of ASCII string | 0A 00 | 00 1010 |
| 88 | 58 | # 2 Padding with "Blank" character | 20 00 | 10 0000 |
| 89 | 59 | # 2 Padding with "Blank" character | 20 00 | 10 0000 |
| 90 | 5A | Detailed timing description # 3 | 00 00 | 00 0000 |
| 91 | 5B | # 3 Flag | 00 00 | 00 0000 |
| 92 | 5C | # 3 Reserved | 00 00 | 00 0000 |
| 93 | 5D | # 3 FE (hex) defines ASCII string (Vendor "CMO", ASCII) | FE 1 | 1111110 |
| 94 | 5E | # 3 Flag | 00 00 | 00 0000 |
| 95 | 5F | # 3 1st character of string ("C") | 43 01 | 00 0011 |
| 96 | 60 | # 3 2nd character of string ("M") | 4D 01 | 00 1101 |
| 97 | 61 | # 3 3rd character of string ("O") | 4F 01 | 00 1111 |
| 98 | 62 | # 3 New line character indicates end of ASCII string | 0A 00 | 00 1010 |
| 99 | 63 | # 3 Padding with "Blank" character | 20 00 | 10 0000 |
| 100 | 64 | # 3 Padding with "Blank" character | 20 00 | 10 0000 |
| 101 | 65 | # 3 Padding with "Blank" character | 20 00 | 10 0000 |
| 102 | 66 | # 3 Padding with "Blank" character | 20 00 | 10 0000 |
| 103 | 67 | # 3 Padding with "Blank" character | 20 00 | 10 0000 |
| 104 | 68 | # 3 Padding with "Blank" character | 20 00 | 10 0000 |
| 105 | 69 | # 3 Padding with "Blank" character | 20 00 | 10 0000 |
| 106 | 6A | # 3 Padding with "Blank" character | 20 00 | 10 0000 |
| 107 | 6B | # 3 Padding with "Blank" character | 20 00 | 10 0000 |
| 108 | 6C | Detailed timing description # 4 | 00 00 | 00 0000 |
| 109 | 6D | # 4 Flag | 00 00 | 00 0000 |
| 110 | 6E | # 4 Reserved | 00 00 | 00 0000 |
| 111 | 6F | # 4 FE (hex) defines ASCII string (Model Name "N101N6-L02", ASCII) | FE 1 | 1111110 |
| 112 | 70 | # 4 Flag | 00 00 | 00 0000 |
| 113 | 71 | # 4 1st character of name ("N") | 4E | 01001110 |
| 114 | 72 | # 4 2nd character of name ("1") | 31 | 00110001 |
| 115 | 73 | # 4 3rd character of name ("0") | 30 | 00110000 |
| 116 | 74 | # 4 4th character of name ("1") | 31 | 00110001 |
| 117 | 75 | # 4 5th character of name ("N") | 4E | 01001110 |
| 118 | 76 | # 4 6th character of name ("6") | 36 | 00110110 |
| 119 | 77 | # 4 7th character of name ("-") | 2D | 00101101 |
| 120 | 78 | # 4 8th character of name ("L") | 4C | 01001100 |
| 121 | 79 | # 4 9th character of name ("0") | 30 00 | 1 10000 |
| 122 | 7A | # 4 9th character of name ("2") | 32 00 | 1 10010 |
| 123 | 7B | # 4 New line character indicates end of ASCII string | 0A 00 | 00 1010 |
| 124 | 7C | # 4 Padding with "Blank" character | 20 00 | 10 0000 |
| 125 | 7D | # 4 Padding with "Blank" character | 20 00 | 10 0000 |
| 126 | 7E | Extension flag | 00 00 | 00 0000 |
| 127 | 7F | Checksum | 03 00 | 00 0011 |

6. CONVERTER SPECIFICATION

6.1 ABSOLUTE MAXIMUM RATINGS

| Symbol | Ratings |
|-------------|------------|
| Vin 29.0V | |
| Gnd +/-0.3V | |
| PWM, EN | -0.3V~7.0V |

6.2 RECOMMENDED OPERATING RATINGS

| Parameter Sy | mbol | Value | | | Unit | Note | |
|--------------------------------------|---------------------|-------|------|------|------|------|-----|
| | | Min. | Typ. | Max. | | | |
| Converter Input power supply voltage | LED_Vccs | 5 | 12 | 20 | V | | |
| EN Control Level | LED_EN | 2.0 | --- | 5.5 | V | | |
| | | 0 | --- | 0.8 | V | | |
| PWM Control Level | PWM | 2 | --- | 5.5 | V | | |
| | | 0 | --- | 0.15 | V | | |
| PWM Control Duty Ratio | | 20 | | 100 | % | | |
| PWM Control Ripple Voltage | V _{PWM_pp} | | | 100 | mV | | |
| PWM Control Frequency | f _{PWM} | 190 | 210 | 230 | Hz | | |
| LED Power Current | LED_VCCS=Min | 250 | 280 | 310 | mA | (1) | |
| | LED_VCCS=Typ | 104 | 1 | 16 | 130 | mA | (1) |
| | LED_VCCS=Max | 62.5 | 70 | | 77.5 | mA | (1) |

Note (1) The specified LED power supply current is under the conditions at "LED_VCCS = Min/Typ/Max", Ta = 25 ± 2 °C, f_{PWM} = 200 Hz, Duty=100%.

6.3 LED BACKLIGHT CONTROL ON/OFF SEQUENCE

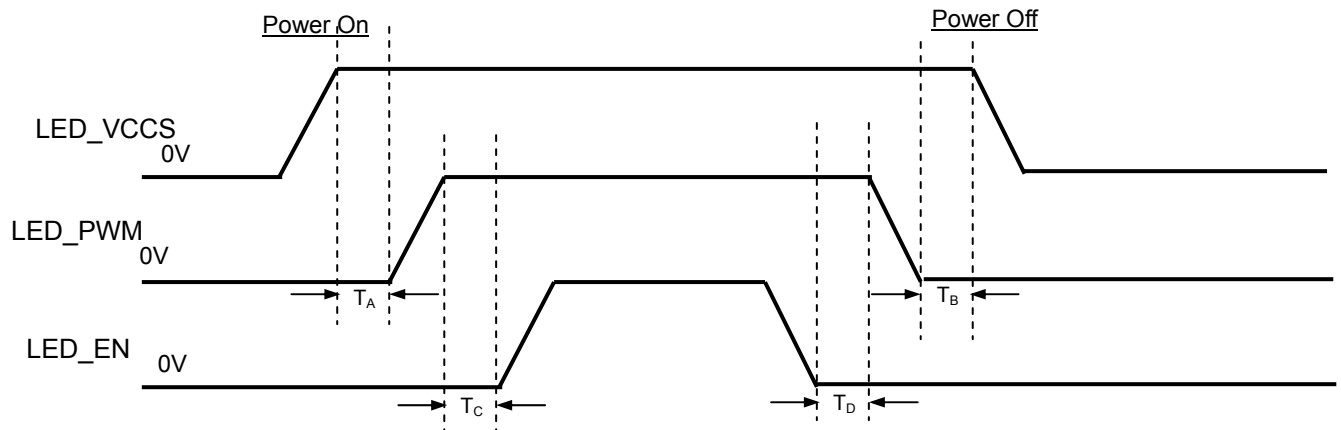

Timing Specifications:

$$T_A \geq 0\text{ms}$$

$$T_B \geq 0\text{ms}$$

$$T_C \geq 0\text{ms}$$

$$T_D \geq 0\text{ms}$$

Note (1) Please follow the LED backlight power sequence as above. If the customer could not follow, it might cause backlight flash issue during display ON/OFF or damage the LED backlight controller

7. INTERFACE TIMING

7.1 INPUT SIGNAL TIMING SPECIFICATIONS

The input signal timing specifications are shown as the following table and timing diagram.

| Signal Item | Symbol | Min. | Typ. | Max. | Unit | Note | |
|----------------|-----------------------------------|-------|--------|-------|--------|------|-----|
| DCLK Frequency | 1/Tc | 37.94 | 42.13 | 44.23 | MHz | (2) | |
| DE | Vertical Total Time | TV | 578 | 593 | 600 | TH | - |
| | Vertical Active Display Period | TVD | 576 | 576 | 576 | TH | - |
| | Vertical Active Blanking Period | TVB | TV-TVD | 17 | TV-TVD | TH | |
| | Horizontal Total Time | TH | 1026 | 1184 | 1224 | Tc | (2) |
| | Horizontal Active Display Period | THD | 1024 | 1024 | 1024 | Tc | (2) |
| | Horizontal Active Blanking Period | THB | TH-THD | 160 | TH-THD | Tc | (2) |

Note (1) Because this module is operated by DE only mode, Hsync and Vsync are ignored.

INPUT SIGNAL TIMING DIAGRAM

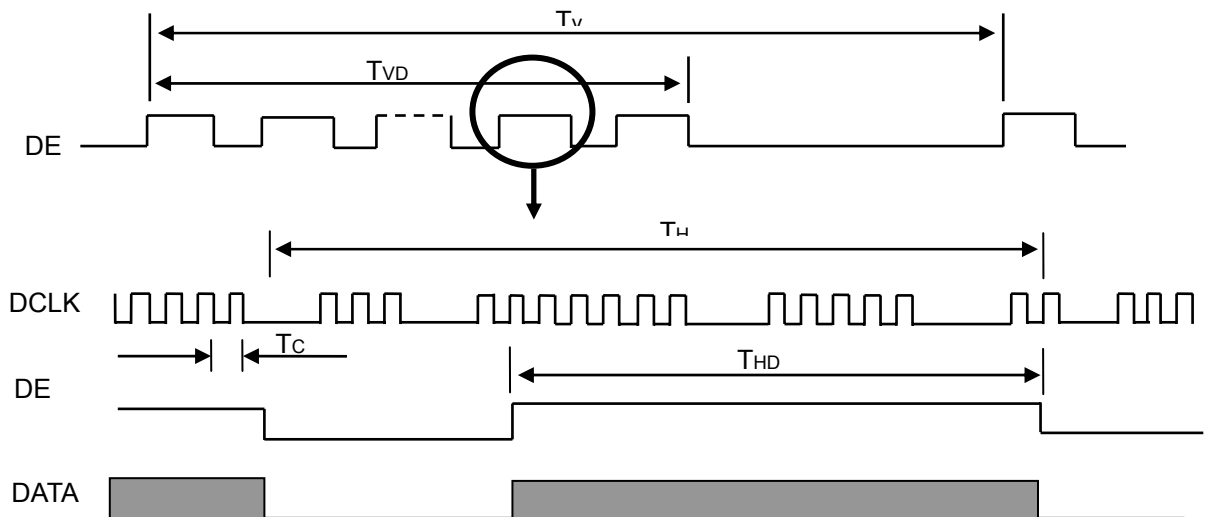

7.2 POWER ON/OFF SEQUENCE

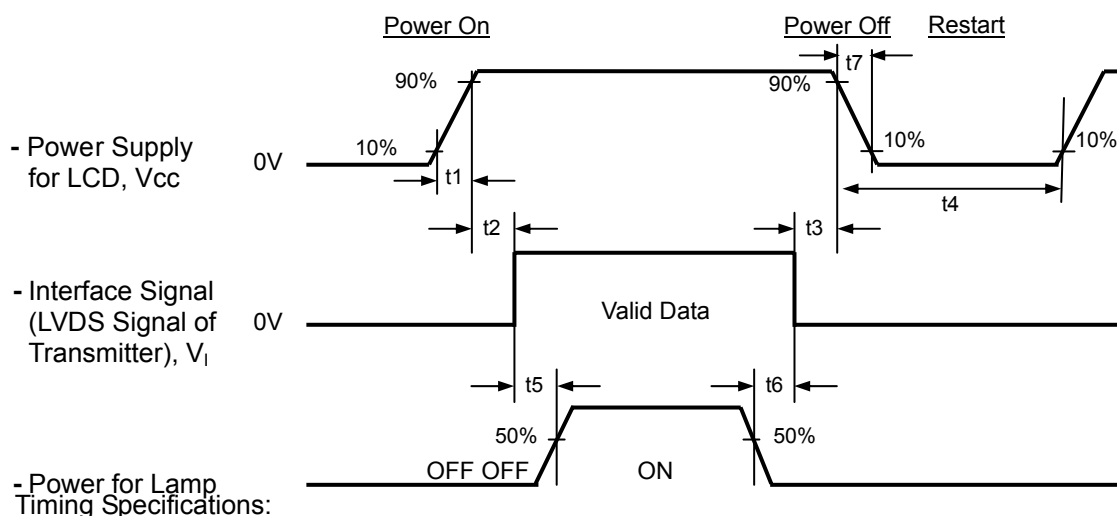

- Power for Lamp
Timing Specifications:

$0.5 < t1 \leq 10 \text{ msec}$
 $0 < t2 \leq 50 \text{ msec}$
 $0 < t3 \leq 50 \text{ msec}$
 $t4 \geq 400 \text{ msec}$
 $t5 \geq 200 \text{ msec}$
 $t6 \geq 200 \text{ msec}$

- Note (1) Please follow the power on/off sequence described above. Otherwise, the LCD module might be damaged.
- Note (2) Please avoid floating state of interface signal at invalid period. When the interface signal is invalid, be sure to pull down the power supply of LCD Vcc to 0 V.
- Note (3) The Backlight inverter power must be turned on after the power supply for the logic and the interface signal is valid. The Backlight inverter power must be turned off before the power supply for the logic and the interface signal is invalid.
- Note (4) Sometimes some slight noise shows when LCD is turned off (even backlight is already off). To avoid this phenomenon, we suggest that the Vcc falling time is better to follow $50\mu\text{s} \leq t7 \leq 10 \text{ ms}$.

8. OPTICAL CHARACTERISTICS

8.1 TEST CONDITIONS

| Item Symbol | | Value | Unit |
|-----------------------------|---|-------|------|
| Ambient Temperature | Ta | 25±2 | °C |
| Ambient Humidity | Ha | 50±10 | %RH |
| Supply Voltage | V _{CC} 3.3 | | V |
| Input Signal | According to typical value in "3. ELECTRICAL CHARACTERISTICS" | | |
| LED Light Bar Input Current | I _L 51 | | mA |

8.2 OPTICAL SPECIFICATIONS

| Item Symbol | | Condition | Min. | Typ. | Max. | Unit | Note |
|-----------------------------|------------|----------------------|---|-------|------------|-------------------|----------|
| Contrast Ratio | | CR | 500 | 650 | - | - | (2), (5) |
| Response Time | | T _R - | | 3 | 8 | ms | (3) |
| | | T _F - | | 7 | 12 | ms | |
| Average Luminance of White | | L _{Ave} | 160 | 200 | - | cd/m ² | (4), (5) |
| Color Chromaticity | Red | R _x | TYP. -0.03 | 0.568 | TYP. +0.03 | - | (1) |
| | | R _y | | 0.352 | | - | |
| | Green | G _x | | 0.339 | | - | |
| | | G _y | | 0.577 | | - | |
| | Blue | B _x | | 0.157 | | - | |
| | | B _y | | 0.130 | | - | |
| | White | W _x 0.313 | | | | - | |
| W _y | | 0.329 | - | | | | |
| Viewing Angle | Horizontal | θ _x + 40 | CR≥10 | 45 | - | Deg. | (1),(5) |
| | | θ _x - 40 | | 45 | - | | |
| | Vertical | θ _y + 15 | | 20 | - | | |
| | | θ _y - | | 40 45 | - | | |
| White Variation of 5 Points | | δW _{5p} | θ _x =0°, θ _y =0° 80 | - | - | % | (5),(6) |

Note (1) Definition of Viewing Angle (θ_x, θ_y):

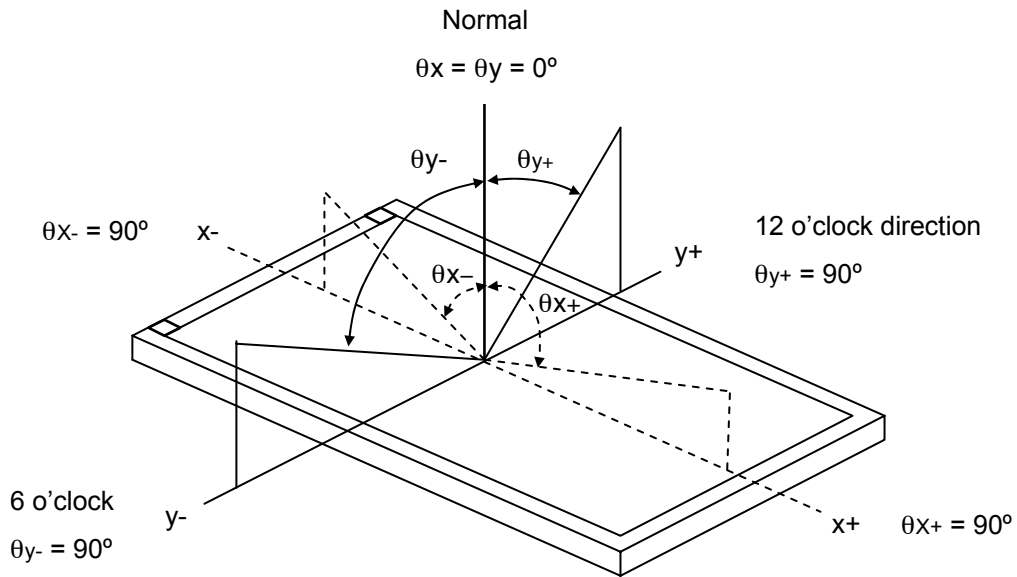

Note (2) Definition of Contrast Ratio (CR):

The contrast ratio can be calculated by the following expression.

$$\text{Contrast Ratio (CR)} = L_{63} / L_0$$

L63: Luminance of gray level 63

L 0: Luminance of gray level 0

$$\text{CR} = \text{CR (1)}$$

CR (X) is corresponding to the Contrast Ratio of the point X at Figure in Note (6).

Note (3) Definition of Response Time (T_R, T_F):

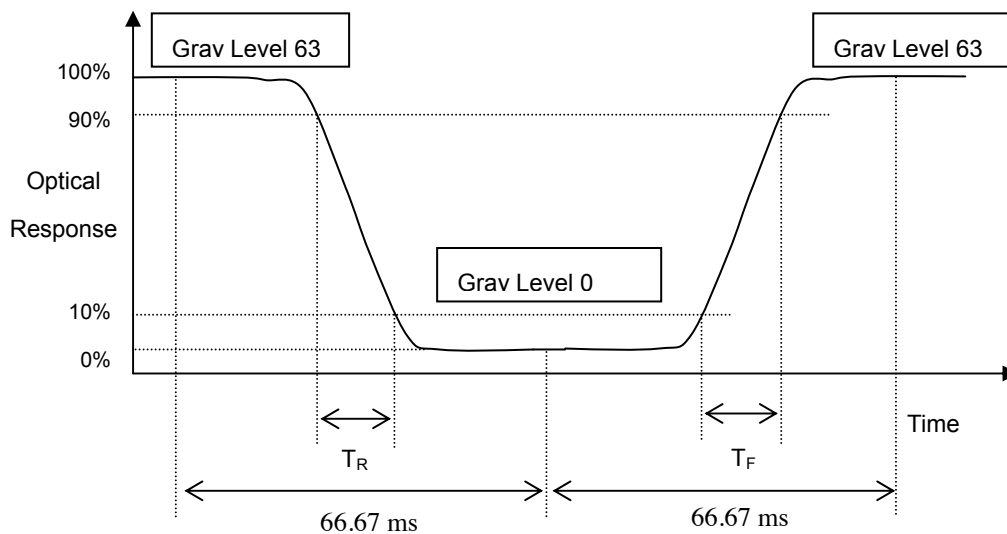

Note (4) Definition of Average Luminance of White (L_{AVE}):

Measure the luminance of gray level 63 at 5 points

$$L_{AVE} = [L(1) + L(2) + L(3) + L(4) + L(5)] / 5$$

L(x) is corresponding to the luminance of the point X at Figure in Note (6)

Note (5) Measurement Setup:

The LCD module should be stabilized at given temperature for 20 minutes to avoid abrupt temperature change during measuring. In order to stabilize the luminance, the measurement should be executed after lighting Backlight for 20 minutes in a windless room.

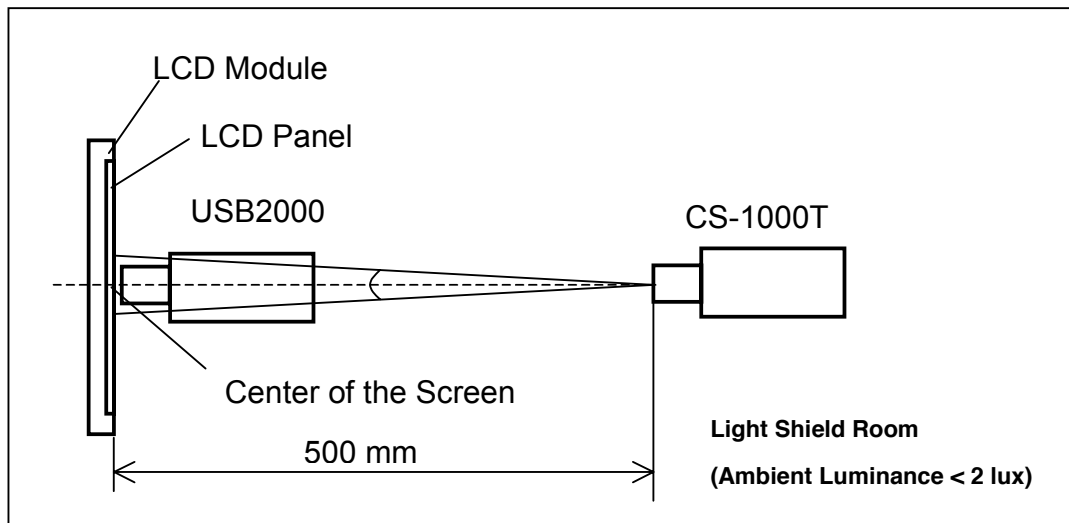

Note (6) Definition of White Variation (δW):

Measure the luminance of gray level 63 at 5 points

$$\delta W_{5p} = \text{Minimum} [L(1) + L(2) + L(3) + L(4) + L(5)] / \text{Maximum} [L(1) + L(2) + L(3) + L(4) + L(5)]$$

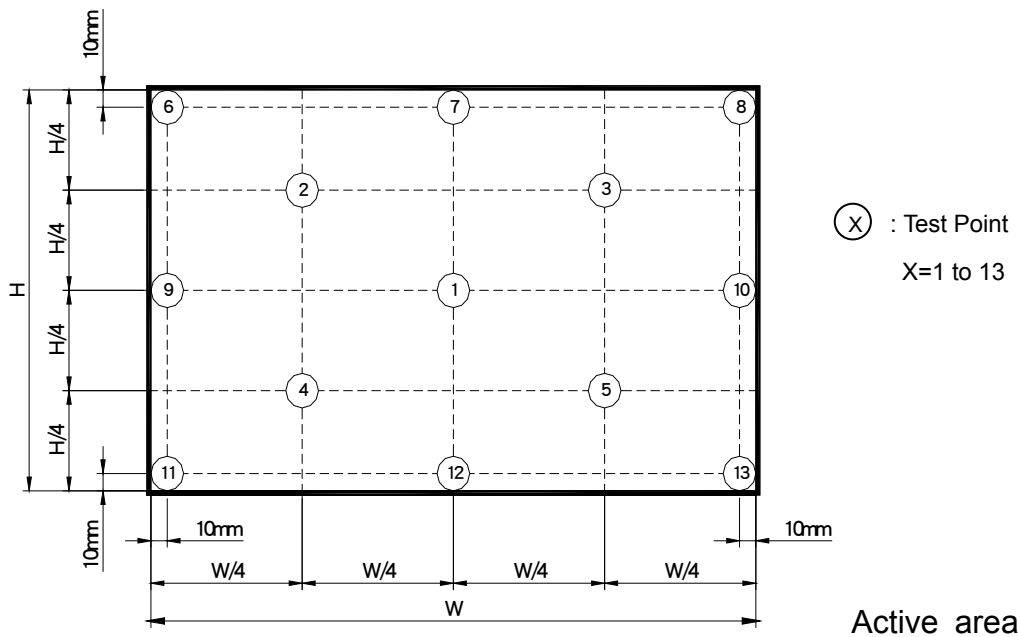

9. PRECAUTIONS

9.1 SYSTEM MATCHING PRECAUTIONS

- (1) Refer to the drawing.
- (2) To avoid wireless noise interference, please keep the antenna away from LCD control board.

9.2 HANDLING PRECAUTIONS

- (1) The module should be assembled into the system firmly by using every mounting hole. Be careful not to twist or bend the module.
- (2) While assembling or installing modules, it can only be in the clean area. The dust and oil may cause electrical short or damage the polarizer.
- (3) Use fingerstalls or soft gloves in order to keep display clean during the incoming inspection and assembly process.
- (4) Do not press or scratch the surface harder than a HB pencil lead on the panel because the polarizer is very soft and easily scratched.
- (5) If the surface of the polarizer is dirty, please clean it by some absorbent cotton or soft cloth. Do not use Ketone type materials (ex. Acetone), Ethyl alcohol, Toluene, Ethyl acid or Methyl chloride. It might permanently damage the polarizer due to chemical reaction.
- (6) Wipe off water droplets or oil immediately. Staining and discoloration may occur if they left on panel for a long time.
- (7) If the liquid crystal material leaks from the panel, it should be kept away from the eyes or mouth. In case of contacting with hands, legs or clothes, it must be washed away thoroughly with soap.
- (8) Protect the module from static electricity, it may cause damage to the C-MOS Gate Array IC.
- (9) Do not disassemble the module.
- (10) Do not pull or fold the lamp wire.
- (11) Pins of I/F connector should not be touched directly with bare hands.

9.3 STORAGE PRECAUTIONS

- (1) High temperature or humidity may reduce the performance of module. Please store LCD module within the specified storage conditions.
- (2) It is dangerous that moisture come into or contacted the LCD module, because the moisture may damage LCD module when it is operating.
- (3) It may reduce the display quality if the ambient temperature is lower than 10 °C. For example, the response time will be come slowly, and the starting voltage of lamp will be higher than the room temperature.

9.4 OPERATION PRECAUTIONS

- (1) Do not pull the I/F connector in or out while the module is operating.
- (2) Always follow the correct power on/off sequence when LCD module is connecting and operating. This can prevent the CMOS LSI chips from damage during latch-up.
- (3) The startup voltage of Backlight is approximately 1000 Volts. It may cause electrical shock while assembling with inverter. Do not disassemble the module or insert anything into the Backlight unit.

9.5 OTHER PRECAUTIONS

- (1) When fixed patterns are displayed for a long time, remnant image is likely to occur.

10. PACKING

10.1 CARTON

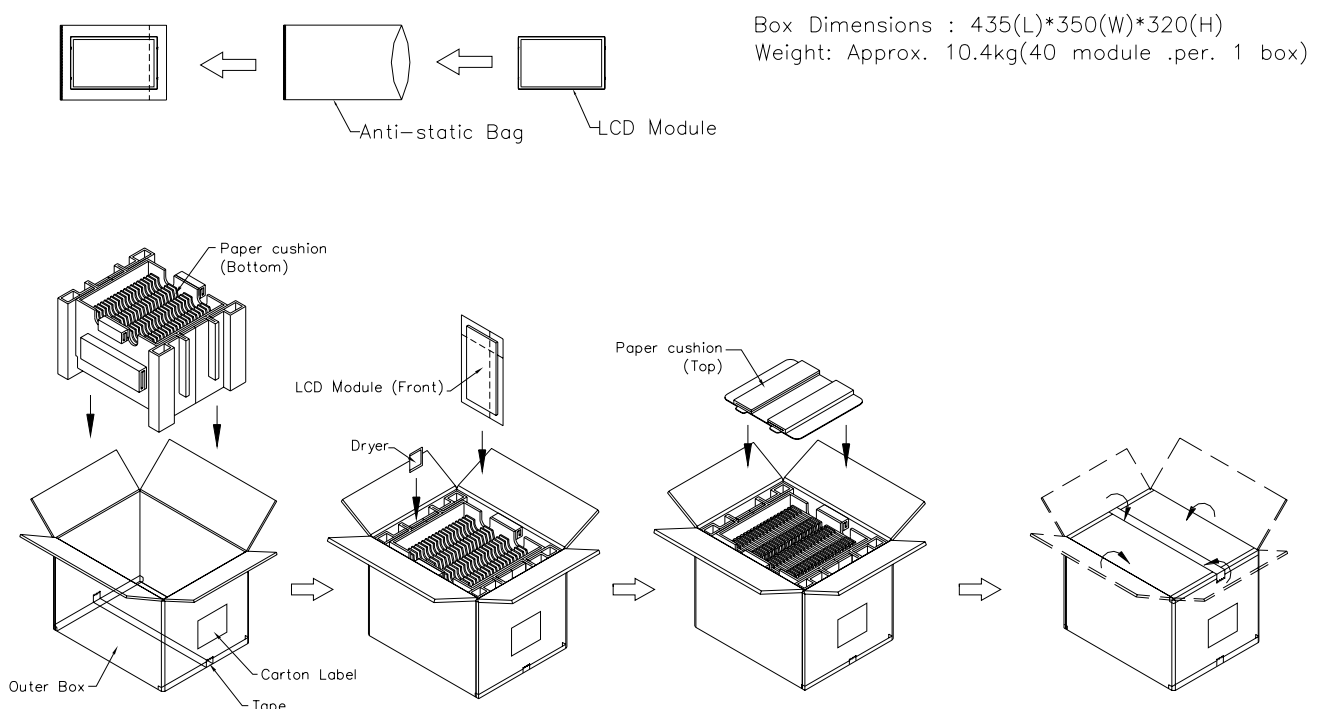

Figure. 10-1 Packing method

10.2 PALLET

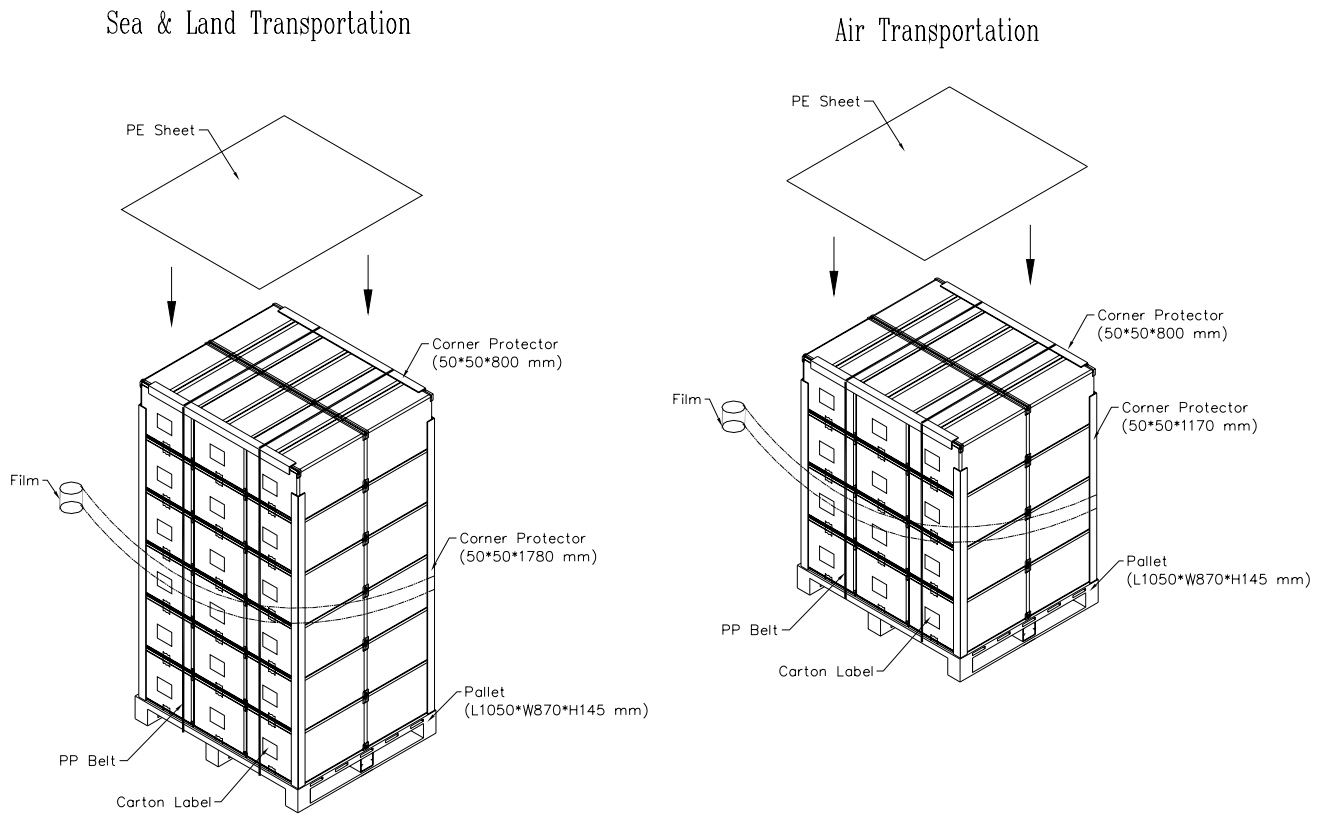

Figure. 10-2 Packing method

11. DEFINITION OF LABELS

11.1 CMO MODULE LABEL

The barcode name plate is pasted on each module as illustration, and its definitions are as following explanation.



(a) Model Name: N101N6 - L02

(b) Revision: Rev. XX, for example: A1, ..., C1, C2 ...etc.

(c) Serial ID: XXXXXXXXYMDXNNNN

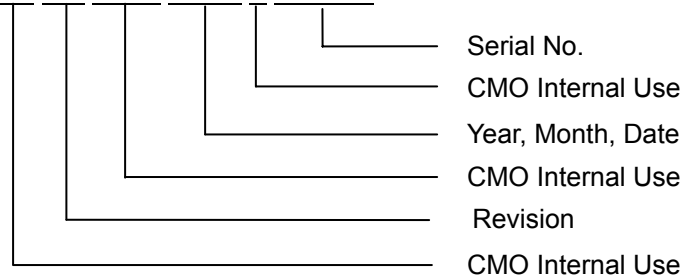

(d) Production Location: MADE IN XXXX. XXXX stands for production location.

Serial ID includes the information as below:

(a) Manufactured Date: Year: 1~9, for 2001~2009

Month: 1~9, A~C, for Jan. ~ Dec.

Day: 1~9, A~Y, for 1st to 31st, exclude I, O and U

- (b) Revision Code: cover all the change
- (c) Serial No.: Manufacturing sequence of product

11.2 CARTON LABEL

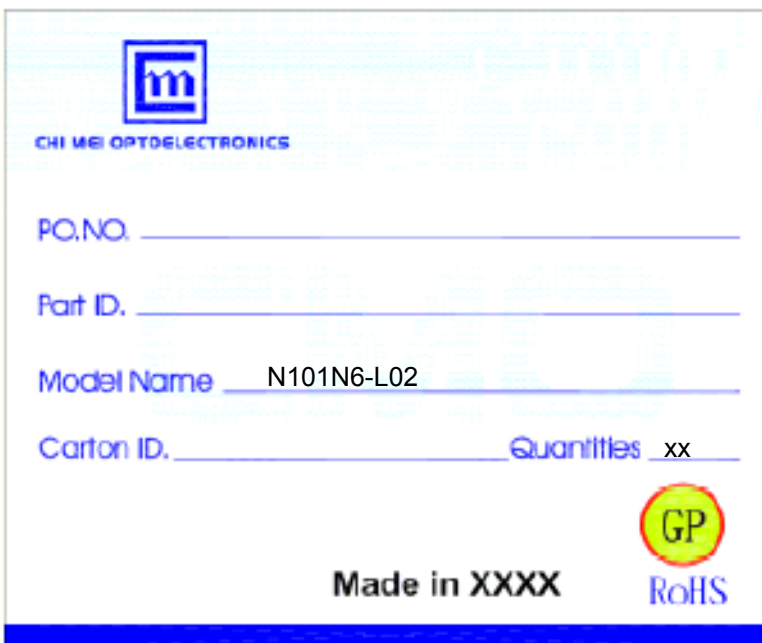

The image shows a template for a carton label. It features the CHI MEI logo and company name at the top left. Below this, there are four horizontal lines for text entry: 'PO.NO.', 'Part ID.', 'Model Name' (with 'N101N6-L02' pre-filled), and 'Carton ID.' followed by 'Quantities' and 'xx'. At the bottom, there is a 'Made in XXXX' label and a circular 'GP' logo with 'RoHS' text below it.

Production location: Made In XXXX. XXXX stands for production location.

