

TFT LCD Preliminary Specification

MODEL NO.: N121I6 - L01

Customer : _____

Approved by : _____

Note :

記錄	工作	審核	角色	投票
2007-04-25 15:29:53 CST	Approve by Dept. Mgr.(QA RA)	yuan_chan(趙俊淵 /52760/54760)	Department Manager(QA RA)	Accept
2007-04-10 15:48:38 CST	Approve by Director	hj_mao(毛旭仁/13070)	Director	Accept

- CONTENTS -

REVISION HISTORY	-----	3
1. GENERAL DESCRIPTION	-----	4
1.1 OVERVIEW		
1.2 FEATURES		
1.3 APPLICATION		
1.4 GENERAL SPECIFICATIONS		
1.5 MECHANICAL SPECIFICATIONS		
2. ABSOLUTE MAXIMUM RATINGS	-----	5
2.1 ABSOLUTE RATINGS OF ENVIRONMENT		
2.2 ELECTRICAL ABSOLUTE RATINGS		
2.2.1 TFT LCD MODULE		
2.2.2 BACKLIGHT UNIT		
3. ELECTRICAL CHARACTERISTICS	-----	7
3.1 TFT LCD MODULE		
3.2 BACKLIGHT UNIT		
4. BLOCK DIAGRAM	-----	9
4.1 TFT LCD MODULE		
5. INPUT TERMINAL PIN ASSIGNMENT	-----	11
5.1 TFT LCD MODULE		
5.2 TIMING DIAGRAM OF LVDS INPUT SIGNAL		
5.3 COLOR DATA INPUT ASSIGNMENT		
5.4 EDID DATA STRUCTURE		
5.5 EDID SIGNAL SPECIFICATION		
6. CONVERTER SPECIFICATION	-----	18
6.1 CONNECTOR TYPE		
6.2 INPUT CONNECTOR PIN ASSIGNMENT		
7. INTERFACE TIMING	-----	19
7.1 INPUT SIGNAL TIMING SPECIFICATIONS		
7.2 POWER ON/OFF SEQUENCE		
8. OPTICAL CHARACTERISTICS	-----	21
8.1 TEST CONDITIONS		
8.2 OPTICAL SPECIFICATIONS		
9. PRECAUTIONS	-----	24
9.1 HANDLING PRECAUTIONS		
9.2 STORAGE PRECAUTIONS		
9.3 OPERATION PRECAUTIONS		
10. PACKING	-----	25
10.1 CARTON		
10.2 PALLET FOR SEA FREIGHT		
10.3 PALLET FOR AIR FREIGHT		
11. DEFINITION OF LABELS	-----	28
11.1 CMO MODULE LABEL		
11.2 CT LABEL		
11.3 CARTON LABEL		

REVISION HISTORY

Version	Date	Page (New)	Section	Description
Ver 1.0	Dec. 08,'06	All	All	Preliminary specification first issued.
Ver 1.1	Apr. 01, '07	4	1.5	Update depth Max value.
		6	2.2	Update BL Units.
		7	3.1	Update TFT LCD Module parameter.
		9	3.2	Update BL Units parameter.
		13	5.4	Update EDID structure.
		18	6.3	Cancelled.
			6.4	Cancelled.
		21	8.2	Update optical specification.
		26	10.2	Update pallet for sea freight.
		27	10.3	Update pallet for air fright.
		28	11.2	Add CT Label section.

1 GENERAL DESCRIPTION

1.1 OVERVIEW

N12116-L01 is a 12.1" TFT Liquid Crystal Display module with LED Backlight unit and 20 pins LVDS interface. This module supports 1280 x 800 Wide-XGA mode and can display 262,144 colors. The optimum viewing angle is at 6 o'clock direction. The converter module for Backlight is not built in.

1.2 FEATURES

- Thin and light weight
- WXGA (1280 x 800 pixels) resolution
- 3.3V LVDS (Low Voltage Differential Signaling) interface with 1 pixel/clock
- Meet RoHS requirement
- LED Backlight

1.3 APPLICATION

- TFT LCD Notebook

1.4 GENERAL SPECIFICATIONS

Item	Specification	Unit	Note
Active Area	261.12 (H) x 163.2 (V) (12.1" diagonal)	mm	(1)
Bezel Opening Area	264.12 (H) x 166.2 (V)	mm	
Driver Element	a-si TFT active matrix	-	-
Pixel Number	1280 x R.G.B. x 800	pixel	-
Pixel Pitch	0.204 (H) x 0.204 (V)	mm	-
Pixel Arrangement	RGB vertical stripe	-	-
Display Colors	262,144	color	-
Transmissive Mode	Normally white	-	-
Surface Treatment	Hard coating (3H), Anti-glare type	-	-

1.5 MECHANICAL SPECIFICATIONS

Item	Min.	Typ.	Max.	Unit	Note	
Module Size	Horizontal(H)	275.3	275.8	276.3	mm	(1)
	Vertical(V)	179	179.5	180	mm	
	Depth(D)	-	4.7	5.0	mm	
Weight	-	220	228	g	(2)	

Note (1) Please refer to the attached drawings for more information of front and back outline dimensions.

(2) Max weight including converter.

2 ABSOLUTE MAXIMUM RATINGS

2.1 ABSOLUTE RATINGS OF ENVIRONMENT

Item	Symbol	Value		Unit	Note
		Min.	Max.		
Storage Temperature	T _{ST}	-20	+60	°C	(1)
Operating Ambient Temperature	T _{OP}	0	+50	°C	(1), (2)
Shock (Non-Operating)	S _{NOP}	-	200/2	G/ms	(3), (5)
Vibration (Non-Operating)	V _{NOP}	-	1.5	G	(4), (5)

Note (1) (a) 90 %RH Max. (T_a ≤ 40 °C).

(b) Wet-bulb temperature should be 39 °C Max. (T_a > 40 °C).

(c) No condensation.

Note (2) The temperature of panel display surface area should be 0 °C Min. and 60 °C Max.

Relative Humidity (%RH)

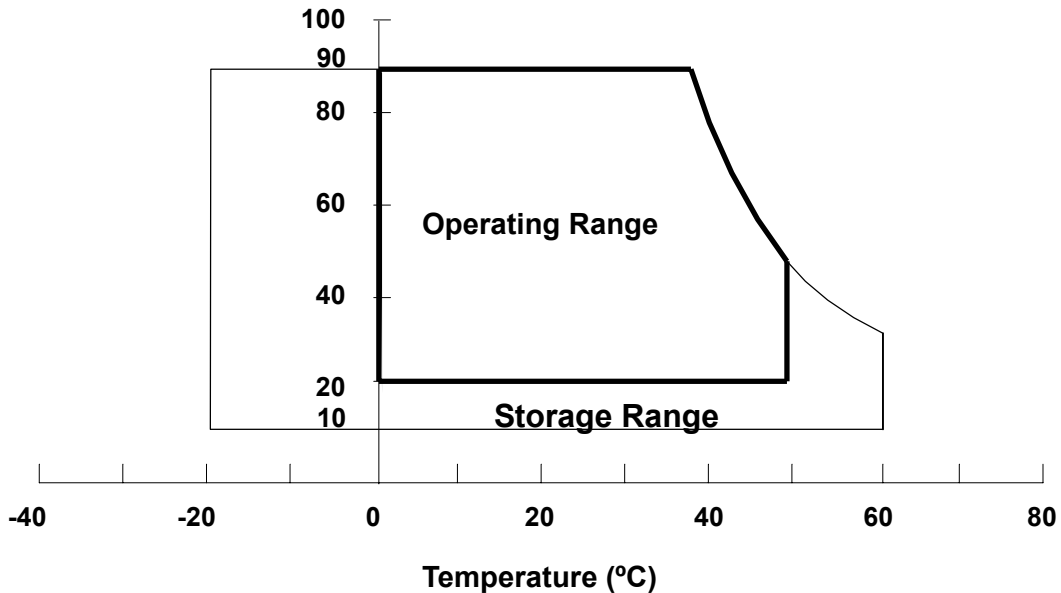

Note (3) 1 time for ± X, ± Y, ± Z. for Condition (200G / 2ms) is half Sine Wave,.

Note (4) 10 ~ 500 Hz, 30 min/cycle, 1 cycles for each X, Y, Z axis.

Note (5) At testing Vibration and Shock, the fixture in holding the module has to be hard and rigid enough so that the module would not be twisted or bent by the fixture.

The fixing condition is shown as below:

At Room Temperature

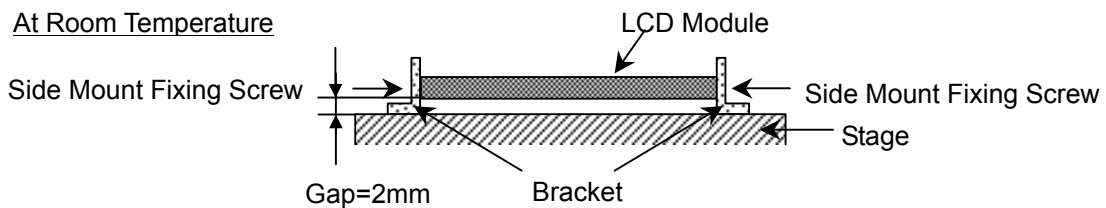

2.2 ELECTRICAL ABSOLUTE RATINGS

2.2.1 TFT LCD MODULE

Item	Symbol	Value		Unit	Note
		Min.	Max.		
Power Supply Voltage	V _{CC}	-0.3	+4.0	V	(1)
Logic Input Voltage	V _{IN}	-0.3	V _{CC} +0.3	V	

2.2.2 BACKLIGHT UNIT

Item	Value			Unit	Note
	Min	Typ.	Max.		
LED Light Bar Input voltage	-	25.6	-	V _{DC}	(1), (2)
LED Light Bar Input Current	-	105	-	mA _{DC}	

Note (1) Permanent damage to the device may occur if maximum values are exceeded. Function operation should be restricted to the conditions described under Normal Operating Conditions.

Note (2) Specified values are for LED (Refer to Section 3.2 for further information).

3 ELECTRICAL CHARACTERISTICS

3.1 TFT LCD MODULE

Parameter	Symbol	Value			Unit	Note
		Min.	Typ.	Max.		
Power Supply Voltage	V _{CC}	3.0	3.3	3.6	V	-
Ripple Voltage	V _{RP}	-		100	mV	-
Rush Current	I _{RUSH}	-	1.2	1.5	A	(2)
Initial Stage Current	I _{IS}			1.0	A	(2)
Power Supply Current	White	-	280	-	mA	(3)a
	Black	-	340	-	mA	(3)b
LVDS Differential Input High Threshold	V _{TH(LVDS)}			+100	mV	(5), V _{CM} =1.2V
LVDS Differential Input Low Threshold	V _{TL(LVDS)}	-100			mV	(5), V _{CM} =1.2V
LVDS Common Mode Voltage	V _{CM}	1.125		1.375	V	(5)
LVDS Differential Input Voltage	V _{ID}	100		600	mV	(5)
Terminating Resistor	R _T	-	100	-	Ohm	-
Power per EBL WG	P _{EBL}	-	TBD		W	(4)

Note (1) The ambient temperature is Ta = 25 ± 2 °C.

Note (2) I_{RUSH}: the maximum current when VCC is rising

I_{IS}: the maximum current of the first 100ms after power-on

Measurement Conditions: Shown as the following figure. Test pattern: black.

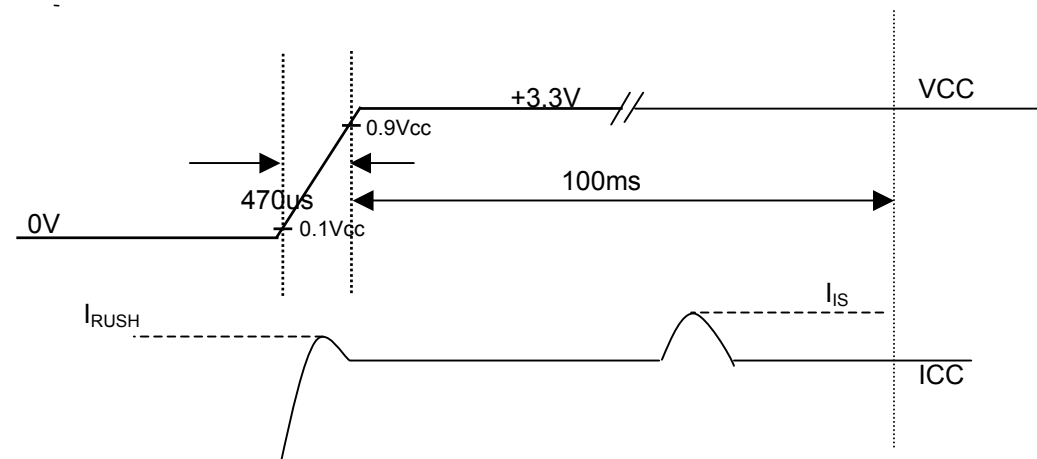
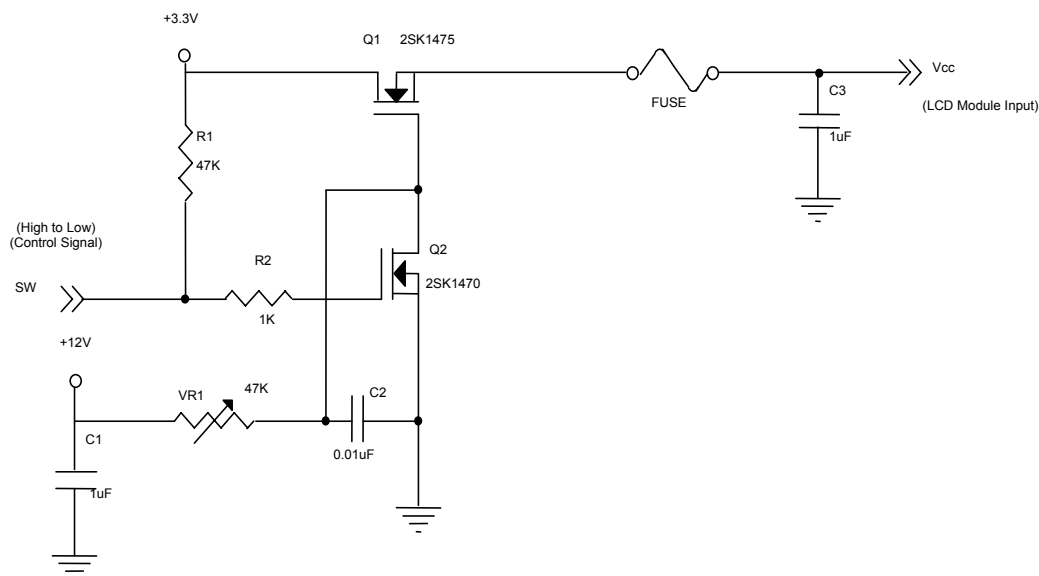

Note (3) The specified power supply current is under the conditions at $V_{cc} = 3.3\text{ V}$, $T_a = 25 \pm 2\text{ }^\circ\text{C}$, DC Current and $f_v = 60\text{ Hz}$, whereas a power dissipation check pattern below is displayed.

a. White Pattern

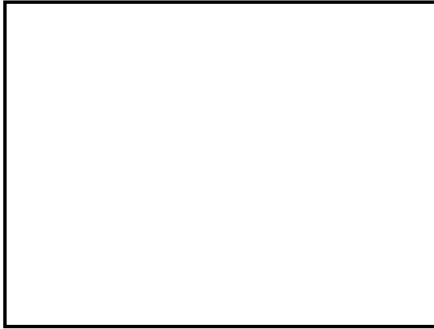

Active Area

b. Black Pattern



Active Area

Note (4) The specified power are the sum of LCD panel electronics input power and the converter input power. Test conditions are as follows.

- (a) $V_{cc} = 3.3\text{ V}$, $T_a = 25 \pm 2\text{ }^\circ\text{C}$, $f_v = 60\text{ Hz}$,
- (b) The pattern used is a black and white 32 x 36 checkerboard, slide #100 from the VESA file "Flat Panel Display Monitor Setup Patterns", FPDMSU.ppt.
- (c) Luminance: 60 nits.
- (d) The converter used is provided from Sumida and Foxconn.

Note (5) The parameters of LVDS signals are defined as the following figures.

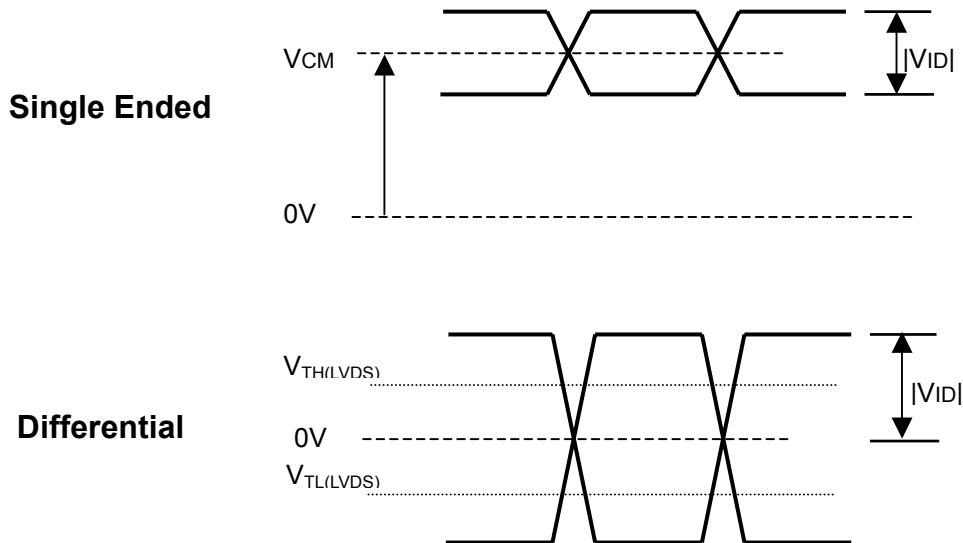

3.2 BACKLIGHT UNIT

Ta = 25 ± 2 °C

Parameter	Symbol	Value			Unit	Note
		Min.	Typ.	Max.		
(LED light bar input voltage)	V _L	-	25.6	-	V _{DC}	(Duty 100%)
(LED light bar input current)	I _L	-	105	-	mA _{DC}	(Duty 100%)
LED Input Voltage	V _f	-	3.2	-	V _{DC}	I _f = 20 mA/EA
LED Current	I _f	-	17.5	-	mA	Per EA
LED Current Peak	I _f	-	-	100	mA _{DC}	(1)
Power Consumption	P _f	-	2.69	-	W	(2), I _f = 17.5 mA/EA
LED Life Time	L _{BL}	10000	-	-	Hrs	(3)

Note (1) LED current is measured by utilizing a high frequency current meter as shown below:

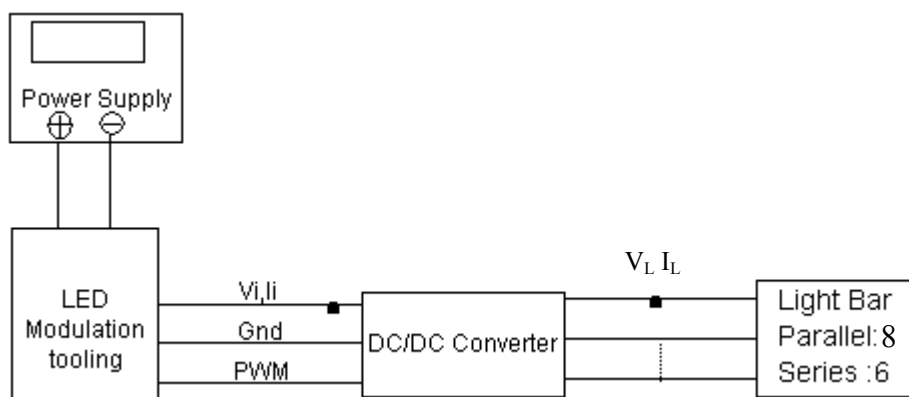

Note (2) $P_L = I_L \times V_L$

Note (3) The lifetime of LED is defined as the time when it continues to operate under the conditions at Ta = 25 ± 2 °C and I = 20 mA(Per EA) until one of the following events occurs:

- (a) When the brightness becomes ≤ 50% of its original value.
- (b) When the effective ignition length becomes ≤ 80% of its original value. (Effective ignition length is defined as an area that the brightness is less than 70% compared to the center point.)

4 BLOCK DIAGRAM

4.1 TFT LCD MODULE

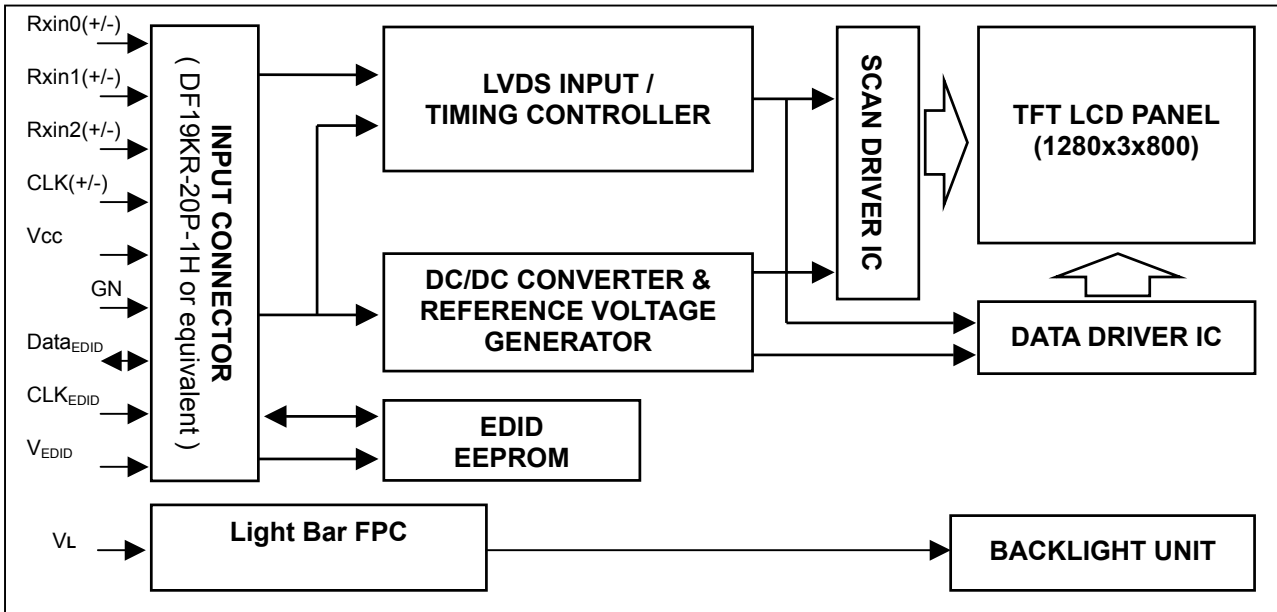

5 INPUT TERMINAL PIN ASSIGNMENT

5.1 TFT LCD MODULE

Pin	Symbol	Description	Polarity	Remark
1	VSS	Ground		-
2	VDD	Power Supply +3.3 V		-
3	VDD	Power Supply +3.3 V		-
4	V _{EDID}	DDC +3.3 V		
5	TEST	Panel Self Test		
6	CLK _{EDID}	DDC Clock		
7	Data _{EDID}	DDC Data		
8	Rxin0-	LVDS Differential Data Input	Negative	R0~R5,G0-
9	Rxin0+	LVDS Differential Data Input	Positive	
10	VSS	Ground		
11	Rxin1-	LVDS Differential Data Input	Negative	G1~G5,B0,B1
12	Rxin1+	LVDS Differential Data Input	Positive	
13	VSS	Ground		
14	Rxin2-	LVDS Differential Data Input	Negative	B2~B5,Hsync,Vsync,DE
15	Rxin2+	LVDS Differential Data Input	Positive	
16	VSS	Ground		
17	CLK-	LVDS Clock Data Input	Negative	LVDS Level
18	CLK+	LVDS Clock Data Input	Positive	
19	VSS	Ground	-	-
20	VSS	Ground	-	-

Note (1) Connector Part No.: DF19KR-20P-1H or equivalent

Note (2) User's connector Part No: DF19G-20S-1C or equivalent

5.2 TIMING DIAGRAM OF LVDS INPUT SIGNAL

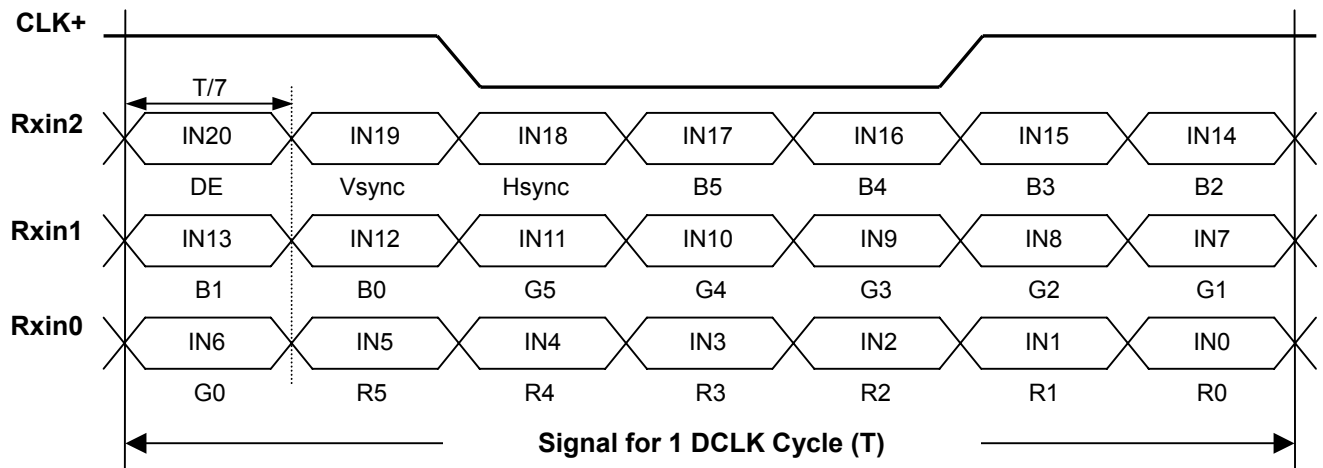

5.3 COLOR DATA INPUT ASSIGNMENT

The brightness of each primary color (red, green and blue) is based on the 6-bit gray scale data input for the color. The higher the binary input the brighter the color. The table below provides the assignment of color versus data input.

Color		Data Signal																	
		Red						Green						Blue					
		R5	R4	R3	R2	R1	R0	G5	G4	G3	G2	G1	G0	B5	B4	B3	B2	B1	B0
Basic Colors	Black	0	0	0	0	0	0	0	0	0	0	0	0	0	0	0	0	0	0
	Red	1	1	1	1	1	1	0	0	0	0	0	0	0	0	0	0	0	0
	Green	0	0	0	0	0	0	1	1	1	1	1	1	0	0	0	0	0	0
	Blue	0	0	0	0	0	0	0	0	0	0	0	0	1	1	1	1	1	1
	Cyan	0	0	0	0	0	0	1	1	1	1	1	1	1	1	1	1	1	1
	Magenta	1	1	1	1	1	1	0	0	0	0	0	0	1	1	1	1	1	1
	Yellow	1	1	1	1	1	1	1	1	1	1	1	1	0	0	0	0	0	0
	White	1	1	1	1	1	1	1	1	1	1	1	1	1	1	1	1	1	1
Gray Scale Of Red	Red(0)/Dark	0	0	0	0	0	0	0	0	0	0	0	0	0	0	0	0	0	0
	Red(1)	0	0	0	0	0	1	0	0	0	0	0	0	0	0	0	0	0	0
	Red(2)	0	0	0	0	1	0	0	0	0	0	0	0	0	0	0	0	0	0
	:	:	:	:	:	:	:	:	:	:	:	:	:	:	:	:	:	:	:
	:	:	:	:	:	:	:	:	:	:	:	:	:	:	:	:	:	:	:
	:	:	:	:	:	:	:	:	:	:	:	:	:	:	:	:	:	:	:
	Red(61)	1	1	1	1	0	1	0	0	0	0	0	0	0	0	0	0	0	0
	Red(62)	1	1	1	1	1	0	0	0	0	0	0	0	0	0	0	0	0	0
Red(63)	1	1	1	1	1	1	0	0	0	0	0	0	0	0	0	0	0	0	
Gray Scale Of Green	Green(0)/Dark	0	0	0	0	0	0	0	0	0	0	0	0	0	0	0	0	0	0
	Green(1)	0	0	0	0	0	0	0	0	0	0	0	1	0	0	0	0	0	0
	Green(2)	0	0	0	0	0	0	0	0	0	0	1	0	0	0	0	0	0	0
	:	:	:	:	:	:	:	:	:	:	:	:	:	:	:	:	:	:	:
	:	:	:	:	:	:	:	:	:	:	:	:	:	:	:	:	:	:	:
	:	:	:	:	:	:	:	:	:	:	:	:	:	:	:	:	:	:	:
	Green(61)	0	0	0	0	0	0	1	1	1	1	0	1	0	0	0	0	0	0
	Green(62)	0	0	0	0	0	0	1	1	1	1	1	0	0	0	0	0	0	0
Green(63)	0	0	0	0	0	0	1	1	1	1	1	1	0	0	0	0	0	0	
Gray Scale Of Blue	Blue(0)/Dark	0	0	0	0	0	0	0	0	0	0	0	0	0	0	0	0	0	0
	Blue(1)	0	0	0	0	0	0	0	0	0	0	0	0	0	0	0	0	0	1
	Blue(2)	0	0	0	0	0	0	0	0	0	0	0	0	0	0	0	0	1	0
	:	:	:	:	:	:	:	:	:	:	:	:	:	:	:	:	:	:	:
	:	:	:	:	:	:	:	:	:	:	:	:	:	:	:	:	:	:	:
	:	:	:	:	:	:	:	:	:	:	:	:	:	:	:	:	:	:	:
	Blue(61)	0	0	0	0	0	0	0	0	0	0	0	0	1	1	1	1	0	1
	Blue(62)	0	0	0	0	0	0	0	0	0	0	0	0	1	1	1	1	1	0
Blue(63)	0	0	0	0	0	0	0	0	0	0	0	0	1	1	1	1	1	1	

Note (1) 0: Low Level Voltage, 1: High Level Voltage

5.4 EDID DATA STRUCTURE

The EDID (Extended Display Identification Data) data formats are to support displays as defined in the VESA Plug & Display and FPD/ standards.

Byte # (decimal)	Byte # (hex)	Field Name and Comments	Value (hex)	Value (binary)
0	0	Header	00	00000000
1	1	Header	FF	11111111
2	2	Header	FF	11111111
3	3	Header	FF	11111111
4	4	Header	FF	11111111
5	5	Header	FF	11111111
6	6	Header	FF	11111111
7	7	Header	00	00000000
8	8	EISA ID manufacturer name ("CMO")	0D	00001101
9	9	EISA ID manufacturer name (Compressed ASCII)	AF	10101111
10	0A	ID product code	21	00100001
11	0B	ID product code	12	00010010
12	0C	ID S/N (fixed "0")	00	00000000
13	0D	ID S/N (fixed "0")	00	00000000
14	0E	ID S/N (fixed "0")	00	00000000
15	0F	ID S/N (fixed "0")	00	00000000
16	10	Week of manufacture (fixed week code)	01	00000001
17	11	Year of manufacture (fixed year code)	10	00010000
18	12	EDID structure version # ("1")	01	00000001
19	13	EDID revision # ("3")	03	00000011
20	14	Video I/P definition ("digital")	80	10000000
21	15	Max H image size ("26cm")	1A	00011010
22	16	Max V image size ("16cm")	10	00010000
23	17	Display Gamma (Gamma = "2.2")	78	01111000
24	18	Feature support ("Active off, RGB Color")	0A	00001010
25	19	Red/Green (Rx1, Rx0, Ry1, Ry0, Gx1, Gx0, Gy1, Gy0)	0D	00001101
26	1A	Blue/White (Bx1, Bx0, By1, By0, Wx1, Wx0, Wy1, Wy0)	62	01100010
27	1B	Red-x (Rx = "0.555")	8E	10001110
28	1C	Red-y (Ry = "0.352")	5A	01011010
29	1D	Green-x (Gx = "0.363")	5C	01011100
30	1E	Green-y (Gy = "0.576")	93	10010011
31	1F	Blue-x (Bx = "0.154")	27	00100111
32	20	Blue-y (By = "0.120")	1E	00011110
33	21	White-x (Wx = "0.313")	50	01010000
34	22	White-y (Wy = "0.329")	5B	01011011
35	23	Established timings 1	00	00000000
36	24	Established timings 2	00	00000000
37	25	Manufacturer's reserved timings	00	00000000
38	26	Standard timing ID # 1	01	00000001
39	27	Standard timing ID # 1	01	00000001
40	28	Standard timing ID # 2	01	00000001
41	29	Standard timing ID # 2	01	00000001

42	2A	Standard timing ID # 3	01	00000001
43	2B	Standard timing ID # 3	01	00000001
44	2C	Standard timing ID # 4	01	00000001
45	2D	Standard timing ID # 4	01	00000001
46	2E	Standard timing ID # 5	01	00000001
47	2F	Standard timing ID # 5	01	00000001
48	30	Standard timing ID # 6	01	00000001
49	31	Standard timing ID # 6	01	00000001
50	32	Standard timing ID # 7	01	00000001
51	33	Standard timing ID # 7	01	00000001
52	34	Standard timing ID # 8	01	00000001
53	35	Standard timing ID # 8	01	00000001
54	36	Detailed timing description # 1 Pixel clock ("71MHz", According to VESA CVT Rev1.1)	BC	10111100
55	37	# 1 Pixel clock (hex LSB first)	1B	00011011
56	38	# 1 H active ("1280")	00	00000000
57	39	# 1 H blank ("160")	A0	10100000
58	3A	# 1 H active : H blank ("1280 : 160")	50	01010000
59	3B	# 1 V active ("800")	20	00100000
60	3C	# 1 V blank ("23")	17	00010111
61	3D	# 1 V active : V blank ("800 :23")	30	00110000
62	3E	# 1 H sync offset ("48")	30	00110000
63	3F	# 1 H sync pulse width ("32")	20	00100000
64	40	# 1 V sync offset : V sync pulse width ("3 : 6")	36	00110110
65	41	# 1 H sync offset : H sync pulse width : V sync offset : V sync width ("48: 32 : 3 : 6")	00	00000000
66	42	# 1 H image size ("261 mm")	05	00000101
67	43	# 1 V image size ("163 mm")	A3	10100011
68	44	# 1 H image size : V image size ("261 : 163")	10	00010000
69	45	# 1 H boarder ("0")	00	00000000
70	46	# 1 V boarder ("0")	00	00000000
71	47	# 1 Non-interlaced, Normal, no stereo, Separate sync, H/V pol Negatives, DE only note: LSB is set to "1" if panel is DE-timing only. H/V can be ignored.	18	00011000
72	48	Detailed timing description # 2	00	00000000
73	49	# 2 Flag	00	00000000
74	4A	# 2 Reserved	00	00000000
75	4B	# 2 FE (hex) defines ASCII string (Model Name "N12116-L01", ASCII)	FE	11111110
76	4C	# 2 Flag	00	00000000
77	4D	# 2 1st character of name ("N")	4E	01001110
78	4E	# 2 2nd character of name ("1")	31	00110001
79	4F	# 2 3rd character of name ("2")	32	00110010
80	50	# 2 4th character of name ("1")	31	00110001
81	51	# 2 5th character of name ("1")	49	01001001
82	52	# 2 6th character of name ("6")	36	00110110
83	53	# 2 7th character of name ("-")	2D	00101101
84	54	# 2 8th character of name ("L")	4C	01001100
85	55	# 2 9th character of name ("0")	30	00110000

86	56	# 2 10th character of name ("1")	31	00110001
87	57	(If <13 char, then terminate with ASCII code 0Ah, set remaining char = 20h)	0A	00001010
88	58	(If <13 char, then terminate with ASCII code 0Ah, set remaining char = 20h)	20	00100000
89	59	(If <13 char, then terminate with ASCII code 0Ah, set remaining char = 20h)	20	00100000
90	5A	Detailed timing description # 3	00	00000000
91	5B	# 3 Flag	00	00000000
92	5C	# 3 Reserved	00	00000000
93	5D	# 3 FE (hex) defines ASCII string (Vendor "CMO", ASCII)	FE	11111110
94	5E	# 3 Flag	00	00000000
95	5F	# 3 1st character of string ("C")	43	01000011
96	60	# 3 2nd character of string ("M")	4D	01001101
97	61	# 3 3rd character of string ("O")	4F	01001111
98	62	(If <13 char, then terminate with ASCII code 0Ah, set remaining char = 20h)	0A	00001010
99	63	(If <13 char, then terminate with ASCII code 0Ah, set remaining char = 20h)	20	00100000
100	64	(If <13 char, then terminate with ASCII code 0Ah, set remaining char = 20h)	20	00100000
101	65	(If <13 char, then terminate with ASCII code 0Ah, set remaining char = 20h)	20	00100000
102	66	(If <13 char, then terminate with ASCII code 0Ah, set remaining char = 20h)	20	00100000
103	67	(If <13 char, then terminate with ASCII code 0Ah, set remaining char = 20h)	20	00100000
104	68	(If <13 char, then terminate with ASCII code 0Ah, set remaining char = 20h)	20	00100000
105	69	(If <13 char, then terminate with ASCII code 0Ah, set remaining char = 20h)	20	00100000
106	6A	(If <13 char, then terminate with ASCII code 0Ah, set remaining char = 20h)	20	00100000
107	6B	(If <13 char, then terminate with ASCII code 0Ah, set remaining char = 20h)	20	00100000
108	6C	Detailed timing description # 4	00	00000000
109	6D	# 4 Flag	00	00000000
110	6E	# 4 Reserved	00	00000000
111	6F	# 4 FE (hex) defines ASCII string (Model Name "N12116-L01", ASCII)	FE	11111110
112	70	# 4 Flag	00	00000000
113	71	# 4 1st character of name ("N")	4E	01001110
114	72	# 4 2nd character of name ("1")	31	00110001
115	73	# 4 3rd character of name ("2")	32	00110010
116	74	# 4 4th character of name ("1")	31	00110001
117	75	# 4 5th character of name ("1")	49	01001001
118	76	# 4 6th character of name ("6")	36	00110110
119	77	# 4 7th character of name ("-")	2D	00101101
120	78	# 4 8th character of name ("L")	4C	01001100
121	79	# 4 9th character of name ("0")	30	00110000
122	7A	# 4 10th character of name ("1")	31	00110001
123	7B	(If <13 char, then terminate with ASCII code 0Ah, set remaining char = 20h)	0A	00001010
124	7C	(If <13 char, then terminate with ASCII code 0Ah, set remaining char = 20h)	20	00100000
125	7D	(If <13 char, then terminate with ASCII code 0Ah, set remaining char = 20h)	20	00100000
126	7E	Extension flag	00	00000000
127	7F	Checksum	FF	11111111

5.5 EDID SIGNAL SPECIFICATION

(1) EDID Power

Parameter	Symbol	Test Condition	Min.	Typ.	Max.	Unit
Power supply voltage	Vcc	—	1.8	—	5.5	V

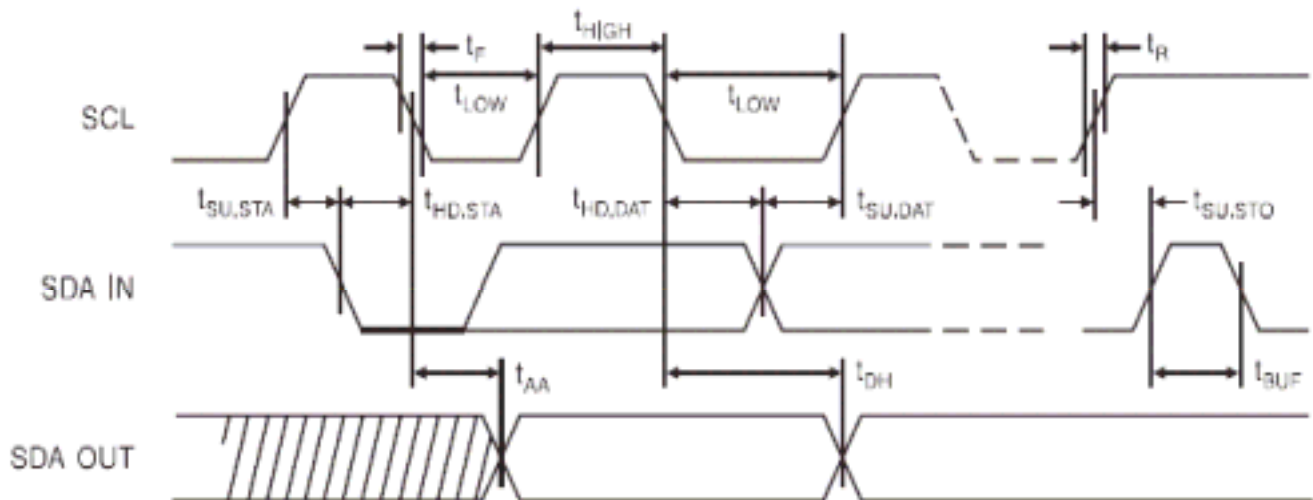

(2) DC characteristics

Parameter	Symbol	Test Condition	Min	Typ	Max	Unit
Supply current Vcc=5.0V	Icc	READ at 100kHz	—	0.4	1.0	mA
Supply current Vcc=5.0V	Icc	WRITE at 100kHz	—	2.0	3.0	mA
Standby Current	ISB	Vin=Vcc or Vss	—	1.6	4.0	μ A
Input Leakage Current	ILI	Vin=Vcc or Vss	—	0.1	3.0	μ A
Output Leakage Current	ILO	Vout=Vcc or Vss	—	0.05	3.0	μ A
Input Low Level	VIL	—	-0.6	—	Vcc x 0.3	V
Input High Level	VIH	—	Vcc x 0.7	—	Vcc+0.5	V
Output Low Level Vcc=3.0V	VOL2	IOL=2.1mA	—	—	0.4	V
Output Low Level Vcc=1.8V	VOL1	IOL=0.15mA	—	—	0.2	V

(3) AC characteristics (VCC=1.8~5.5V standard operation mode)

Parameter	Symbol	Min	Max	Unit
Clock Frequency, SCL	F _{SCL}	—	400	kHz
Clock Pulse Width Low	T _{LOW}	1.2	—	μs
Clock Pulse Width High	T _{HIGH}	0.6	—	μs
Noise Suppression Time	T _I	—	50	ns
Clock Low to Data Out Valid	T _{AA}	0.1	0.9	μs
Time the bus must be free before a new transmission can start	T _{BUF}	1.2	—	μs
Start Hold Time	T _{HD.STA}	0.6	—	μs
Start Set-up Time	T _{SU.STA}	0.6	—	μs
Data in Hold Time	T _{HD.DAT}	0	—	μs
Data in Set-up Time	T _{SU.DAT}	100	—	ns
Inputs Rise Time	T _R	—	0.3	μs
Inputs Fall Time	T _F	—	300	ns
Stop Set-up Time	T _{SU.STO}	0.6	—	μs
Data Out Hold Time	T _{DH}	50	—	ns
Write Cycle Time	T _{WR}	—	5	ms

6 CONVERTER SPECIFICATION

6.1 Connector type

Input connector type: **Aces 87213 (or JST SM07B-SRSS-TB)**

Output connector: **HIROSE FH19SC-8S-0.5SH(0.5)**

6.2 Input connector pin assignment

Input Connector pin assignment:

Input connector		Comments
Aces	87213	
Pin	Function	
1	ALS signal	ALS control (enable:5V, disable:0V)
2	BL-ADJ(output)	Brightness 20%min ~ 100% Max,220±50Hz
3	SW5V	and LED driver board IC enable pin(high enable, low disable.)
4	GND	Ground
5	GND	Ground
6	VIN	Input voltage Power Supply + (8~21V)
7	VIN	Input voltage Power Supply + (8~21V)

7 INTERFACE TIMING

7.1 INPUT SIGNAL TIMING SPECIFICATIONS

The input signal timing specifications are shown as the following table and timing diagram.

Signal	Item	Symbol	Min.	Typ.	Max.	Unit	Note
DCLK	Frequency	1/Tc	-	71	73	MHz	-
DE	Vertical Total Time	TV	802	823	840	TH	-
	Vertical Addressing Time	TVD	800	800	800	TH	-
	Horizontal Total Time	TH	1380	1440	1450	Tc	-
	Horizontal Addressing Time	THD	1280	1280	1280	Tc	-

INPUT SIGNAL TIMING DIAGRAM

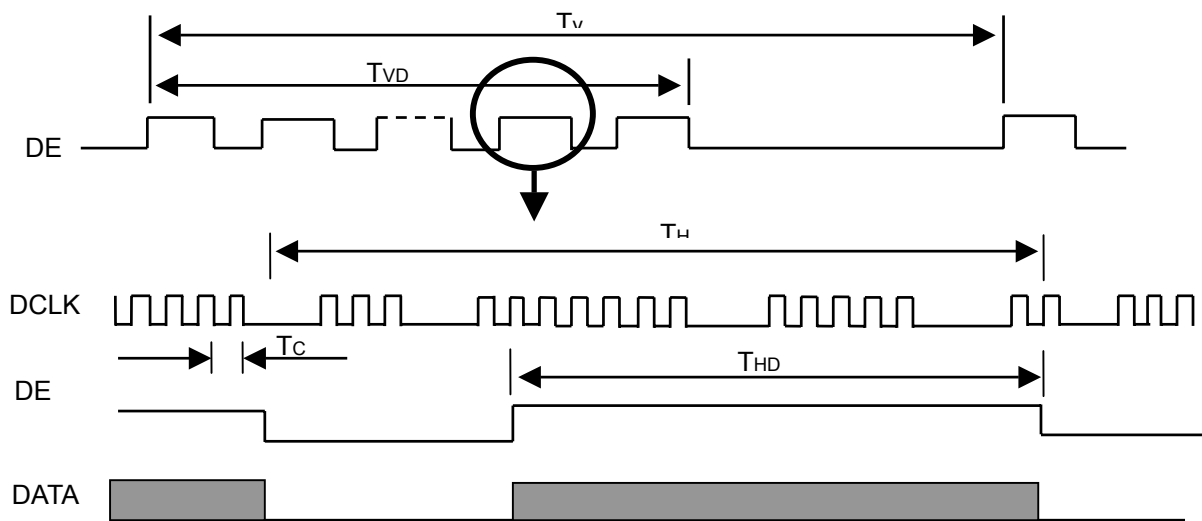

7.2 POWER ON/OFF SEQUENCE

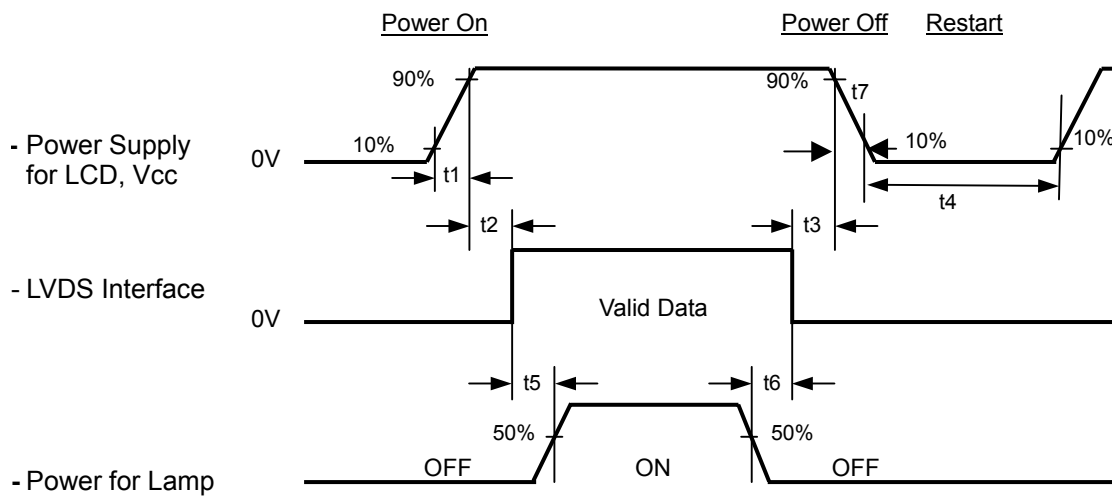

Timing Specifications:

$$0.5\text{ms} < t_1 \leq 10 \text{ msec}$$

$$0 < t_2 \leq 50 \text{ msec}$$

$$0 < t_3 \leq 50 \text{ msec}$$

$$t_4 \geq 500 \text{ msec}$$

$$t_5 \geq \text{TBD msec}$$

$$t_6 \geq \text{TBD msec}$$

Note (1) Please avoid floating state of interface signal at invalid period.

Note (2) When the interface signal is invalid, be sure to pull down the power supply of LCD Vcc to 0 V.

Note (3) The Backlight converter power must be turned on after the power supply for the logic and the interface signal is valid. The Backlight converter power must be turned off before the power supply for the logic and the interface signal is invalid.

Note (4) Sometimes some slight noise shows when LCD is turned off (even backlight is already off). To avoid this phenomenon, we suggest that the Vcc falling time had better to follow

$$t_7 \geq 5 \text{ msec}$$

8 OPTICAL CHARACTERISTICS

8.1 TEST CONDITIONS

Item	Symbol	Value	Unit
Ambient Temperature	T _a	25±2	°C
Ambient Humidity	H _a	50±10	%RH
Supply Voltage	V _{CC}	3.3	V
Input Signal	According to typical value in "3. ELECTRICAL CHARACTERISTICS"		
LED Light Bar Input Current	I _L	105	mA

The measurement methods of optical characteristics are shown in Section 8.2. The following items should be measured under the test conditions described in Section 8.1 and stable environment shown in Note (6).

8.2 OPTICAL SPECIFICATIONS

Item		Symbol	Condition	Min.	Typ.	Max.	Unit	Note
Contrast Ratio		CR	$\theta_x=0^\circ, \theta_y=0^\circ$ Viewing Normal Angle	200	300	-	-	(2), (5)
Response Time		T _R		-	5	10	ms	(3)
		T _F		-	11	16	ms	
Luminance of White (5P)		L _{AVE}		160	200	-	cd/m ²	(4), (5)
White Variation		δW		-	-	1.40	-	(5), (6)
Color Chromaticity	Red	R _x	$\theta_x=0^\circ, \theta_y=0^\circ$ Viewing Normal Angle	Typ.- 0.05	0.562	Typ.+ 0.05	-	(1), (5)
		R _y			0.354		-	
	Green	G _x			0.355		-	
		G _y			0.580		-	
	Blue	B _x			0.152		-	
		B _y			0.137		-	
	White	W _x			0.313		-	
		W _y			0.329		-	
Viewing Angle	Horizontal	θ_{x+}	CR≥10	40	45	-	Deg.	(1), (5)
		θ_{x-}		40	45	-		
	Vertical	θ_{y+}		15	20	-		
		θ_{y-}		40	45	-		

Note (1) Definition of Viewing Angle (θ_x, θ_y):

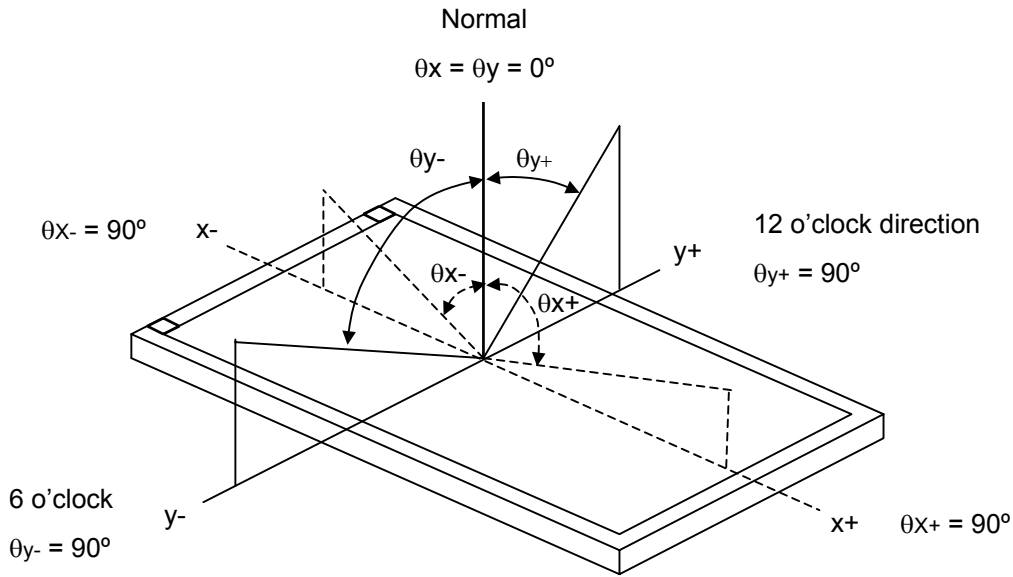

Note (2) Definition of Contrast Ratio (CR):

The contrast ratio can be calculated by the following expression.

$$\text{Contrast Ratio (CR)} = L_{63} / L_0$$

L63: Luminance of gray level 63

L 0: Luminance of gray level 0

$$\text{CR} = \text{CR} (5)$$

CR (X) is corresponding to the Contrast Ratio of the point X at Figure in Note (6).

Note (3) Definition of Response Time (T_R, T_F):

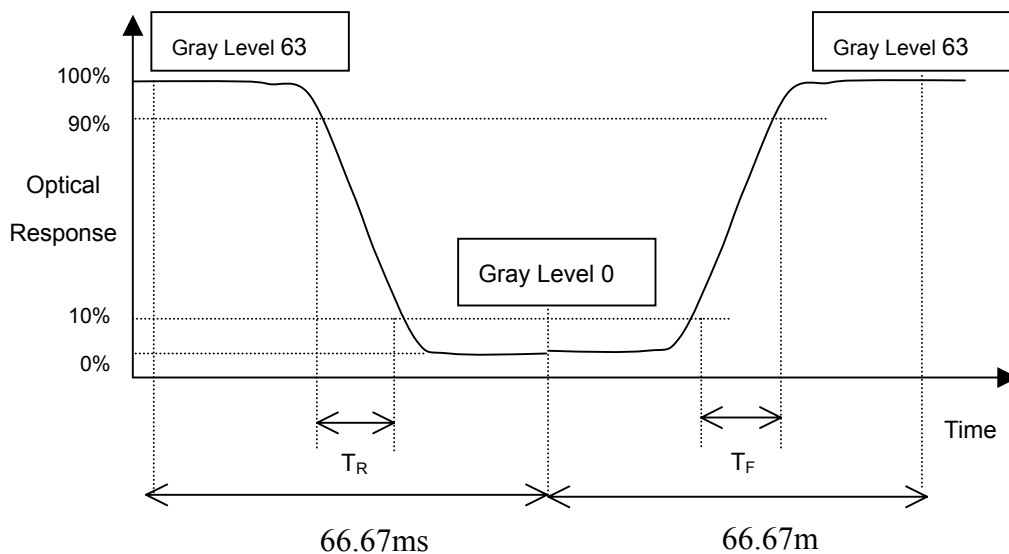

Note (4) Definition of Average Luminance of White (L_{AVE}):

Measure the luminance of gray level 63 at 5 points

$$L_{AVE} = [L(1) + L(2) + L(3) + L(4) + L(5)] / 5$$

$L(x)$ is corresponding to the luminance of the point X at Figure in Note (6).

Note (5) Measurement Setup:

The LCD module should be stabilized at given temperature for 20 minutes to avoid abrupt temperature change during measuring. In order to stabilize the luminance, the measurement should be executed after lighting Backlight for 20 minutes in a windless room.

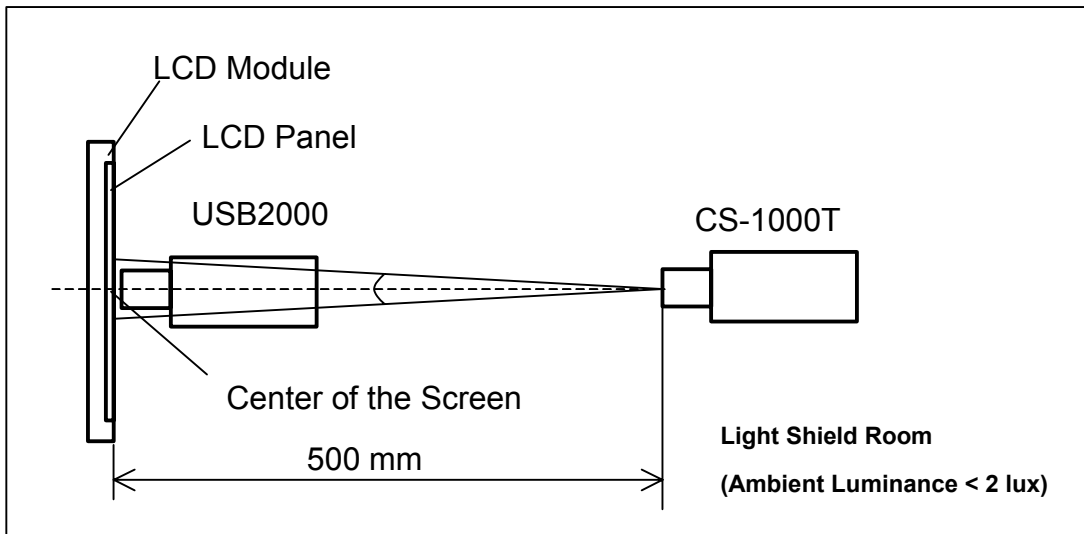

Note (6) Definition of White Variation (δW):

Measure the luminance of gray level 63 at 5 points

$$\delta W = \text{Maximum} [L(1), L(2), L(3), L(4), L(5)] / \text{Minimum} [L(1), L(2), L(3), L(4), L(5)]$$

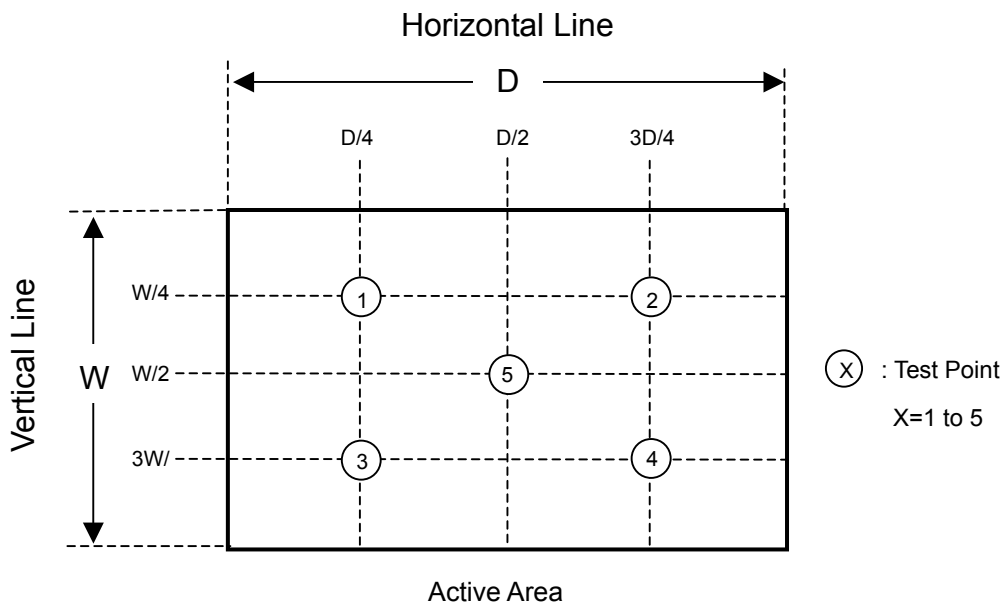

9 PRECAUTIONS

9.1 HANDLING PRECAUTIONS

- (1) The module should be assembled into the system firmly by using every mounting hole. Be careful not to twist or bend the module.
- (2) While assembling or installing modules, it can only be in the clean area. The dust and oil may cause electrical short or damage the polarizer.
- (3) Use fingerstalls or soft gloves in order to keep display clean during the incoming inspection and assembly process.
- (4) Do not press or scratch the surface harder than a HB pencil lead on the panel because the polarizer is very soft and easily scratched.
- (5) If the surface of the polarizer is dirty, please clean it by some absorbent cotton or soft cloth. Do not use Ketone type materials (ex. Acetone), Ethyl alcohol, Toluene, Ethyl acid or Methyl chloride. It might permanently damage the polarizer due to chemical reaction.
- (6) Wipe off water droplets or oil immediately. Staining and discoloration may occur if they left on panel for a long time.
- (7) If the liquid crystal material leaks from the panel, it should be kept away from the eyes or mouth. In case of contacting with hands, legs or clothes, it must be washed away thoroughly with soap.
- (8) Protect the module from static electricity, it may cause damage to the C-MOS Gate Array IC.
- (9) Do not disassemble the module.
- (10) Do not pull or fold the lamp wire.
- (11) Pins of I/F connector should not be touched directly with bare hands.

9.2 STORAGE PRECAUTIONS

- (1) High temperature or humidity may reduce the performance of module. Please store LCD module within the specified storage conditions.
- (2) It is dangerous that moisture come into or contacted the LCD module, because the moisture may damage LCD module when it is operating.
- (3) It may reduce the display quality if the ambient temperature is lower than 10 °C. For example, the response time will become slowly, and the starting voltage of lamp will be higher than the room temperature.

9.3 OPERATION PRECAUTIONS

- (1) Do not pull the I/F connector in or out while the module is operating.
- (2) Always follow the correct power on/off sequence when LCD module is connecting and operating. This can prevent the CMOS LSI chips from damage during latch-up.
- (3) The startup voltage of Backlight is approximately 1000 Volts. It may cause electrical shock while assembling with converter. Do not disassemble the module or insert anything into the Backlight unit.

10 PACKING

10.1 CARTON

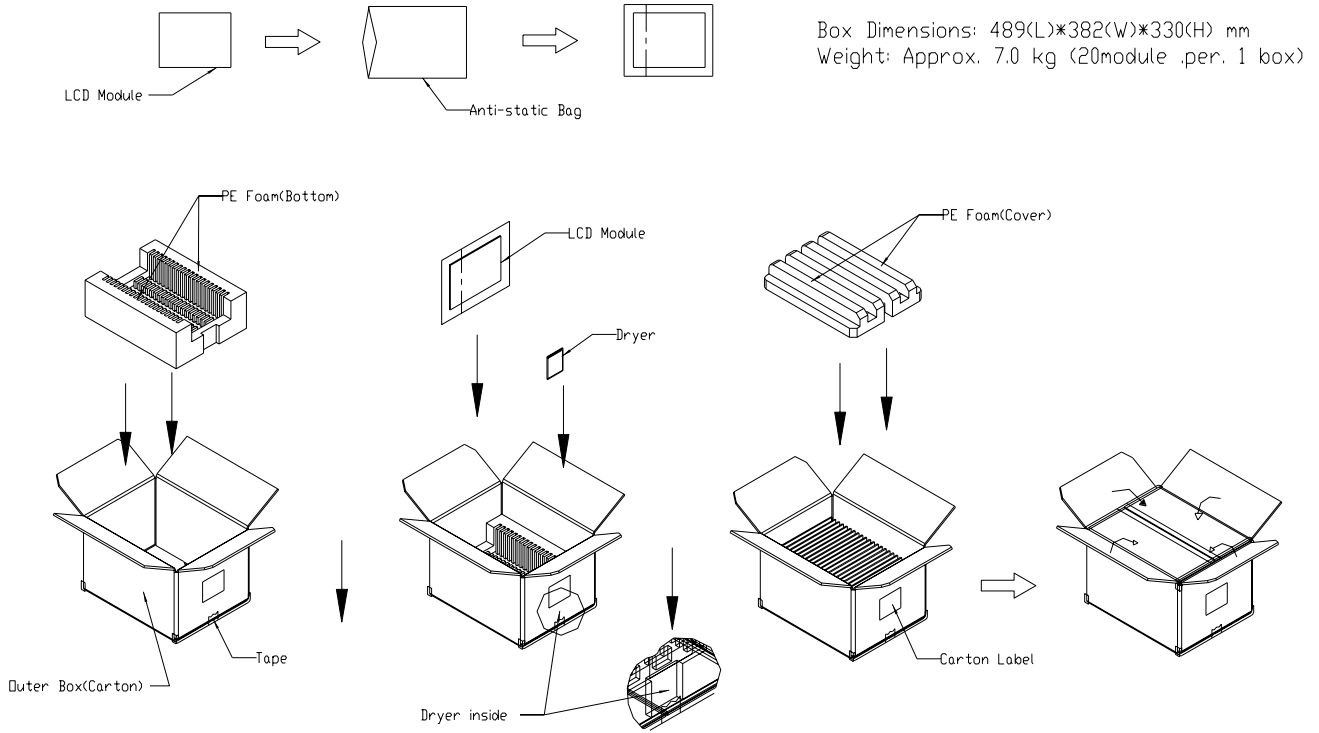

Figure. 10-1 Packing method

10.2 PALLET FOR SEA FREIGHT

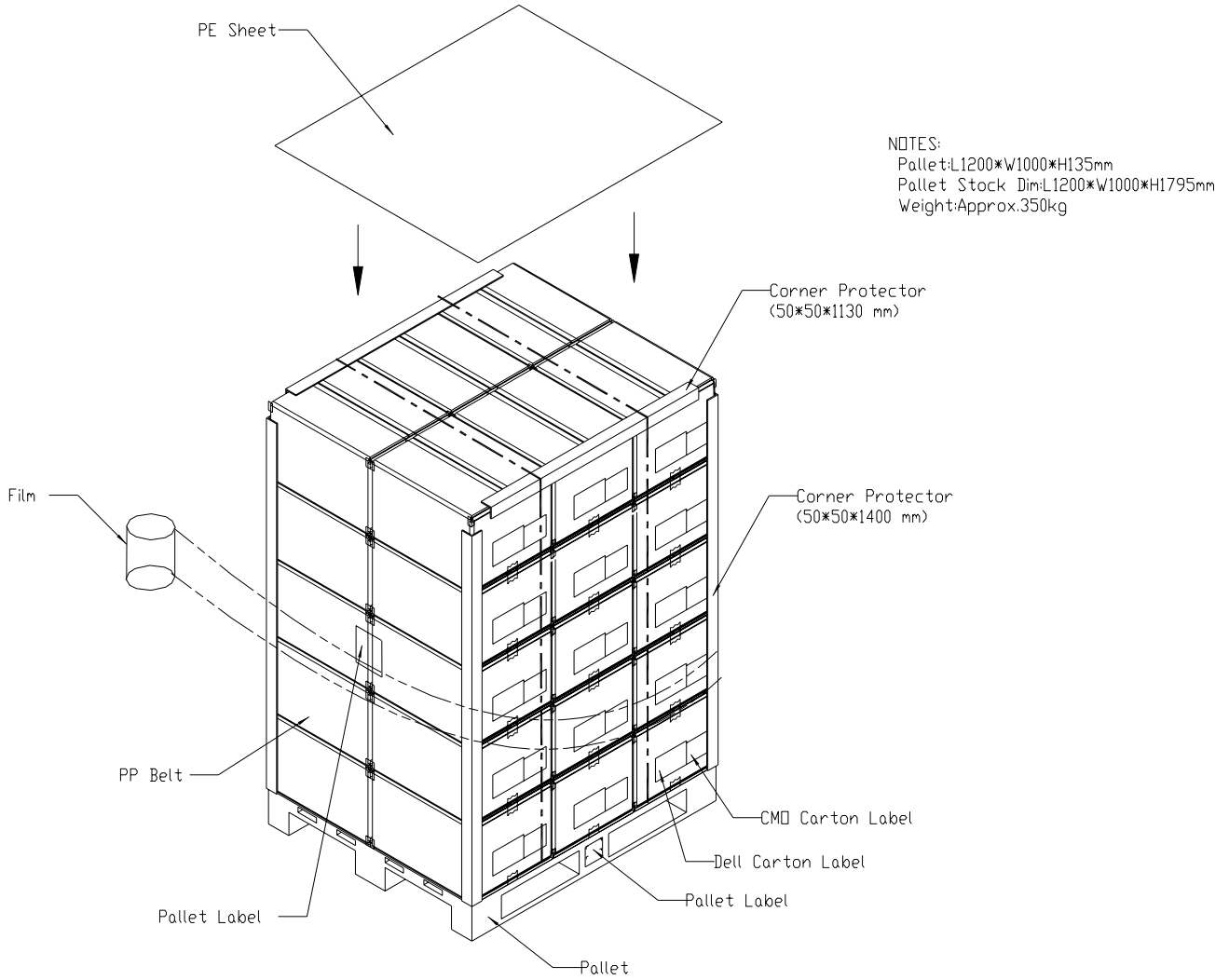

Figure. 10-2 Packing method

10.3 PALLET FOR AIR FREIGHT

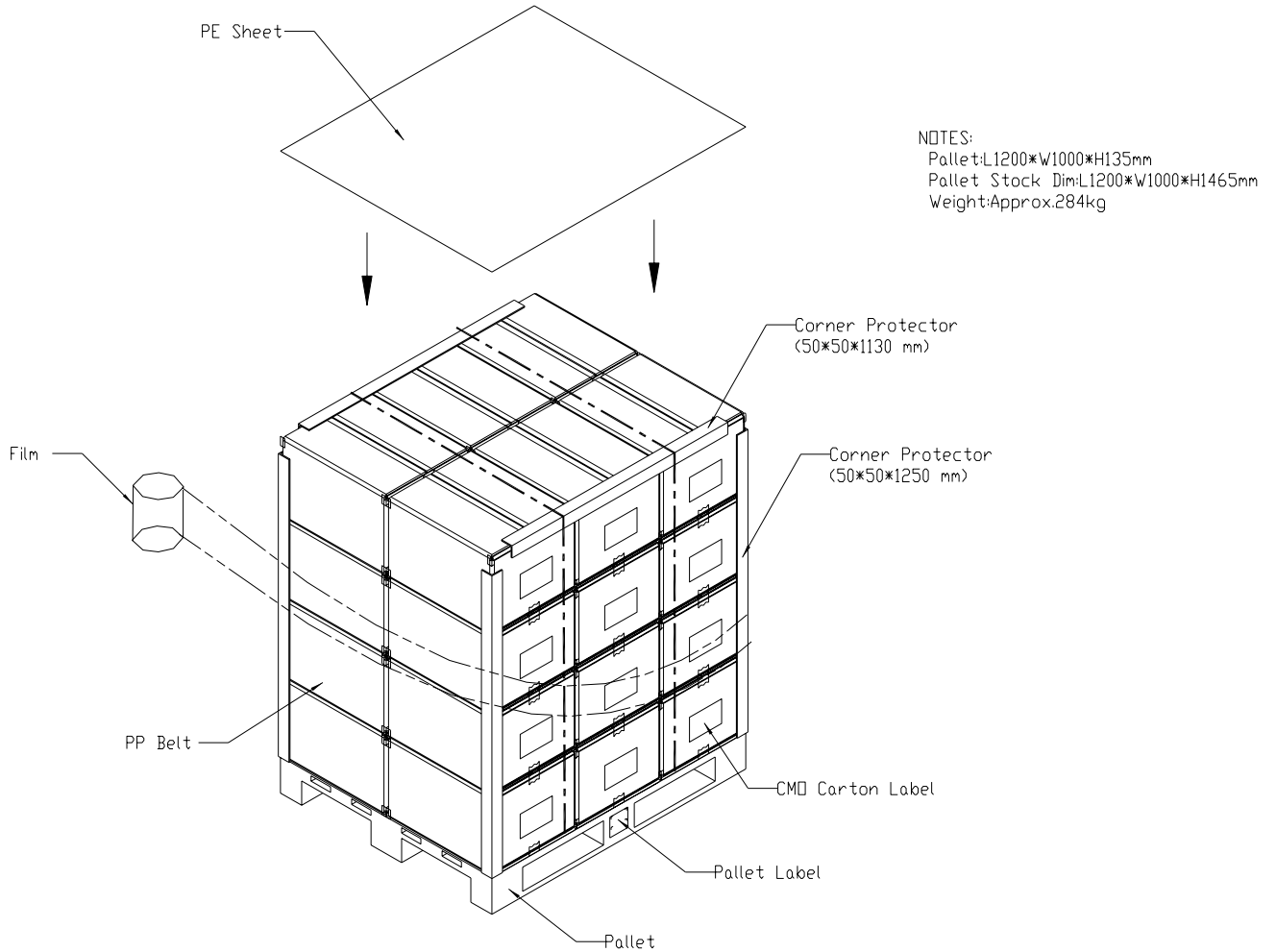

Figure. 10-3 Packing method

11 DEFINITION OF LABELS

11.1 CMO MODULE LABEL

The barcode nameplate is pasted on each module as illustration, and its definitions are as following explanation.



- (a) Model Name: N12116 - L01
- (b) Revision: Rev. XX, for example: C1, C2 ...etc.
- (c) Serial ID: XXXXXXYMDLNNNN

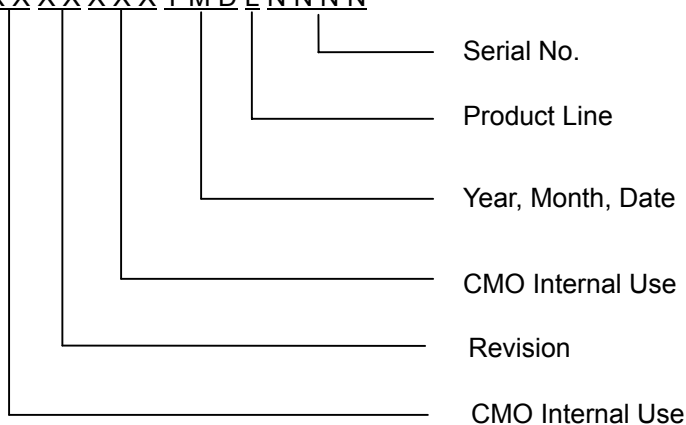

Serial ID includes the information as below:

- (a) Manufactured Date: Year: 1~9, for 2001~2009
 Month: 1~9, A~C, for Jan. ~ Dec.
 Day: 1~9, A~Y, for 1st to 31st, exclude I , O and U
- (b) Revision Code: cover all the change
- (c) Serial No.: Manufacturing sequence of product
- (d) Serial ID line two is for internal production control.

11.2 CT Label

S/N	CT:CCCC7XXVRXXXXX
CT:	Title
C	LCD Display Module
CCC7	Assembly Code
XX	Revision
VR	Supplier /Site of MFG
XX	Week/Year of MFG
XXX	Serial number. From 000000 to 999999

11.3 CARTON LABEL



The image shows a rectangular carton label with a white background and a blue border. At the top left is the CHI MEI logo (a square with 'm' inside) and the text 'CHI MEI OPTOELECTRONICS'. Below this are several fields: 'PO.NO.' followed by a horizontal line; 'Part ID.' followed by a horizontal line; 'Model Name' followed by a horizontal line containing the text 'N12116-L01'; 'Carton ID.' followed by a barcode and the text 'SDA020158CW003'; and 'Quantities' followed by a horizontal line containing the text 'XX'. At the bottom left is the date '06/04', at the bottom center is the text 'Made in XXXX', and at the bottom right is a circular 'GP' logo above the text 'RoHS'.

- (a) Model Name: N12116-L01
- (b) Production year and month: shown at left down corner
- (c) Production location: Made in XXXX

