

TFT LCD Approval Specification

MODEL NO.: V201B1 - L03

Customer: _____

Approved by: _____

Note:

Approved By	TV Head Division	
	LY Chen	

Reviewed By	QRA Dept.	Product Development Div.
	Tomy Chen	WT Lin

Prepared By	LCD TV Marketing and Product Management Div.	
	Ken Wu	Sabrina Lee

- CONTENTS -

REVISION HISTORY	-----	3
1. GENERAL DESCRIPTION	-----	4
1.1 OVERVIEW		
1.2 FEATURES		
1.3 APPLICATION		
1.4 GENERAL SPECIFICATIONS		
1.5 MECHANICAL SPECIFICATIONS		
2. ABSOLUTE MAXIMUM RATINGS	-----	5
2.1 ABSOLUTE RATINGS OF ENVIRONMENT		
2.2 ELECTRICAL ABSOLUTE RATINGS		
2.2.1 TFT LCD MODULE		
2.2.2 BACKLIGHT UNIT		
3. ELECTRICAL CHARACTERISTICS	-----	7
3.1 TFT LCD MODULE		
3.2 BACKLIGHT INVERTER UNIT		
3.2.1 CCFL(Cold Cathode Fluorescent Lamp) CHARACTERISTICS		
4. BLOCK DIAGRAM	-----	10
4.1 TFT LCD MODUL		
5. INTERFACE PIN CONNECTION	-----	11
5.1 TFT LCD MODULE		
5.2 BACKLIGHT UNIT		
5.3 BLOCK DIAGRAM OF INTERFACE		
5.4 LVDS INTERFACE		
5.5 COLOR DATA INPUT ASSIGNMENT		
6. INTERFACE TIMING	-----	16
6.1 INPUT SIGNAL TIMING SPECIFICATIONS		
6.2 POWER ON/OFF SEQUENCE		
7. OPTICAL CHARACTERISTICS	-----	19
7.1 TEST CONDITIONS		
7.2 OPTICAL SPECIFICATIONS		
8. DEFINITION OF LABELS	-----	23
8.1 CMO MODULE LABEL		
9. PACKAGING	-----	24
9.1 PACKING SPECIFICATIONS		
9.2 PACKING METHOD		
10. PRECAUTIONS	-----	26
10.1 ASSEMBLY AND HANDLING PRECAUTIONS		
10.2 SAFETY PRECAUTIONS		
11. MECHANICAL CHARACTERISTICS	-----	27

REVISION HISTORY

Version	Date	Page (New)	Section	Description
Ver 2.0	Feb. 07, '06	All	All	Approval Specification was first issued.
Ver 2.0	Feb. 07, '06	All	All	RoHS compliance.
Ver 2.1	May. 09, '07	All	All	Increasing length of FFC. Model version changed from C1 to C2.
Ver 2.2	Aug. 14, '07	25	9.2	Changing packing method. (3 layers of cartons per pallet ->5 layers of cartons per pallet)
	Oct. 19, '07	19	7.2	Revised CT

1. GENERAL DESCRIPTION

1.1 OVERVIEW

V201B1- L03 is a 20.1" TFT Liquid Crystal Display module with 5-CCFL Backlight unit and 1ch-LVDS interface. This module supports 1366 x 768 WXGA format and can display true 16.2M colors (6-bits+FRC). The inverter module for backlight is not built-in. This product is non-use of Level1 substances.

1.2 FEATURES

- High brightness (500 nits)
- High contrast ratio (1000:1)
- Fast response time (8ms)
- High color saturation NTSC 75%
- WXGA (1366 x 768 pixels) resolution
- DE (Data Enable) only mode
- LVDS (Low Voltage Differential Signaling) interface
- Optimized response time for 60 Hz frame rate
- Ultra wide viewing angle: 176(H)/176(V) (CR>20) Super MVA technology
- 180 degree rotation display option

1.3 APPLICATION

- Home TV
- Public Display Application
- Terminal Display for Video Application

1.4 GENERAL SPECIFICATIONS

Item	Specification	Unit	Note
Active Area	444.633(H) x 249.984 (V) (20.1" diagonal)	mm	(1)
Bezel Opening Area	450.7 (H) x 256 (V)	mm	
Driver Element	a-si TFT active matrix	-	
Pixel Number	1366 x R.G.B. x 768	pixel	
Pixel Pitch (Sub Pixel)	108.5 (H) x 325.5 (V)	um	
Pixel Arrangement	RGB vertical stripe	-	
Display Colors	16.2M	color	
Display Operation Mode	Transmissive mode / Normally black	-	
Surface Treatment	Hardness : 3H, Anti-Glare	-	

1.5 MECHANICAL SPECIFICATIONS

Item	Min.	Typ.	Max.	Unit	Note
Module Size	Horizontal(H)	472.6	473.3	474	mm
	Vertical(V)	276	276.7	277.4	mm
	Depth(D)	35.45	36.45	37.45	mm
Weight	1850	1950	2050	g	

Note (1) Please refer to the attached drawings for more information of front and back outline dimensions.

2. ABSOLUTE MAXIMUM RATINGS

2.1 ABSOLUTE RATINGS OF ENVIRONMENT

Item	Symbol	Value		Unit	Note
		Min.	Max.		
Storage Temperature	T _{ST}	-20	+60	°C	(1)
Operating Ambient Temperature	T _{OP}	0	+50	°C	(1), (2)
Shock (Non-Operating)	S _{NOF}	-	50	G	(3), (5)
Vibration (Non-Operating)	V _{NOF}	-	1.0	G	(4), (5)

Note (1) Temperature and relative humidity range is shown in the figure below.

(a) 90 %RH Max. ($T_a \leq 40$ °C).

(b) Wet-bulb temperature should be 39 °C Max. ($T_a > 40$ °C).

(c) No condensation.

Note (2) The maximum operating temperature is based on the test condition that the surface temperature of display area is less than or equal to 60 °C with LCD module alone in a temperature controlled chamber. Thermal management should be considered in final product design to prevent the surface temperature of display area from being over 60 °C. The range of operating temperature may degrade in case of improper thermal management in final product design.

Note (3) 11 ms, half sine wave, 1 time for $\pm X$, $\pm Y$, $\pm Z$.

Note (4) 10 ~ 500 Hz, 10 min, 1 time each X, Y, Z.

Note (5) At testing Vibration and Shock, the fixture in holding the module has to be hard and rigid enough so that the module would not be twisted or bent by the fixture.

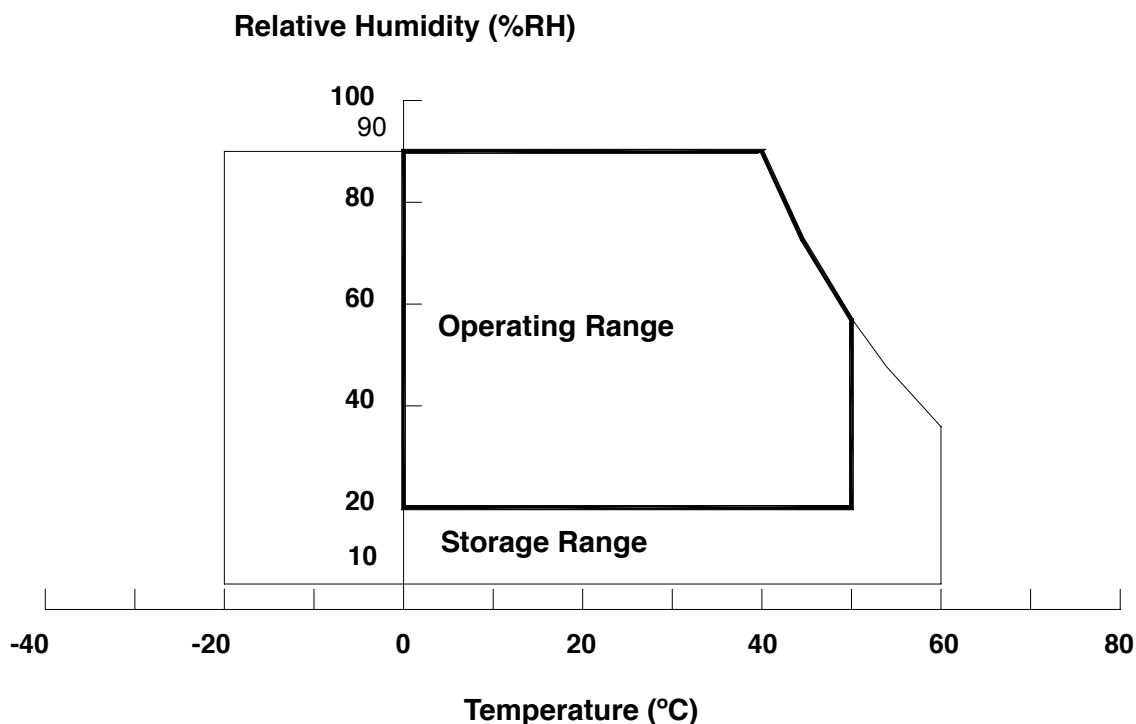

2.2 ELECTRICAL ABSOLUTE RATINGS

2.2.1 TFT LCD MODULE

Item	Symbol	Value		Unit	Note
		Min.	Max.		
Power Supply Voltage	V _{CC}	-0.3	6.0	V	
Input Signal Voltage	V _{IN}	-0.3	3.6	V	

2.2.2 BACKLIGHT UNIT

Item	Symbol	Value		Unit	Note
		Min.	Max.		
Lamp Voltage	V _W	—	3000	V _{RMS}	

3. ELECTRICAL CHARACTERISTICS

3.1 TFT LCD MODULE

Ta = 25 ± 2 °C

Parameter	Symbol	Value			Unit	Note	
		Min.	Typ.	Max.			
Power Supply Voltage	V _{CC}	4.5	5.0	5.5	V	(1)	
Power Supply Ripple Voltage	V _{RP}	-	-	100	mV		
Rush Current	I _{RUSH}	-	-	2.8	A	(2)	
Power Supply Current	White	I _{CC}	-	1.25	-	A	(3)
	Black		-	0.78	-	A	
	Vertical Stripe		-	1.05	-	A	
LVDS Interface	Differential Input High Threshold Voltage	V _{LVTH}	-	-	+100	mV	
	Differential Input Low Threshold Voltage	V _{LVTL}	-100	-	-	mV	
	Common Input Voltage	V _{LVC}	1.125	1.25	1.375	V	
	Terminating Resistor	R _T	-	100	-	ohm	
CMOS interface	Input High Threshold Voltage	V _{IH}	2.7	-	3.3	V	
	Input Low Threshold Voltage	V _{IL}	0	-	0.7	V	

Note (1) The module should be always operated within above ranges.

Note (2) Measurement Conditions:

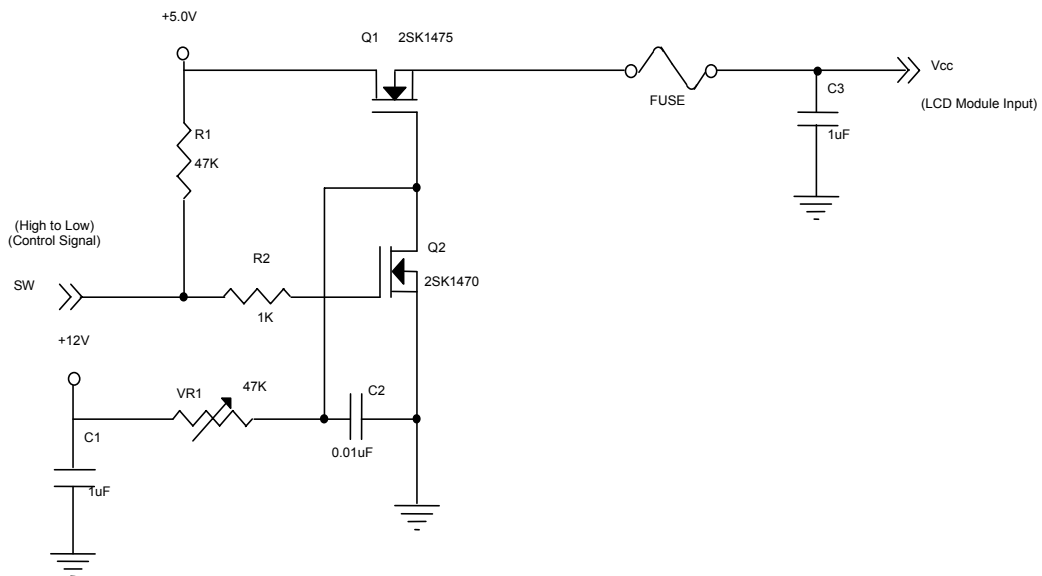

Vcc rising time is 470us

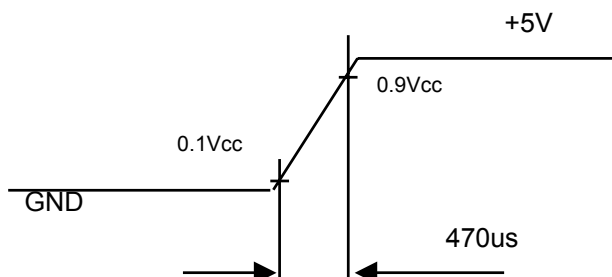

Note (3) The specified power supply current is under the conditions at $V_{cc} = 5\text{ V}$, $T_a = 25 \pm 2\text{ }^\circ\text{C}$, $f_v = 60\text{ Hz}$, whereas a power dissipation check pattern below is displayed.

a. White Pattern



Active Area

b. Black Pattern



Active Area

c. Vertical Stripe Pattern

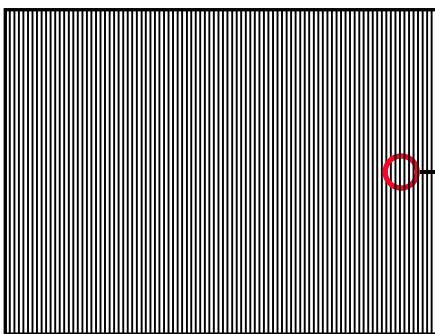

Active Area

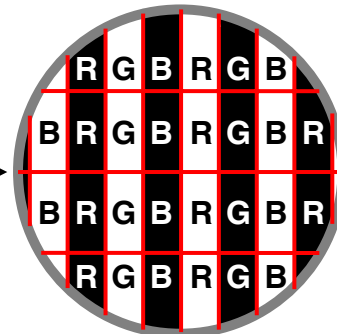

3.2 BACKLIGHT INVERTER UNIT

3.2.1 CCFL (Cold Cathode Fluorescent Lamp) CHARACTERISTICS ($T_a = 25 \pm 2\text{ }^\circ\text{C}$)

Parameter	Symbol	Value			Unit	Note
		Min.	Typ.	Max.		
Lamp Voltage	V_W	-	1610	-	V_{RMS}	$I_L = 5.3\text{mA}$
Lamp Current	I_L	4.8	5.3	5.8	mA_{RMS}	(1)
Lamp Starting Voltage	V_S	-	-	2400	V_{RMS}	(2), $T_a = 0\text{ }^\circ\text{C}$
		-	-	2250	V_{RMS}	(2), $T_a = 25\text{ }^\circ\text{C}$
Operating Frequency	F_O	40	-	70	KHZ	(3)
Lamp Life Time	L_{BL}	50,000	60,000	-	Hrs	(4)

Note (1) Lamp current is measured by current probe (Tekronix P6022) with Tekronix oscilloscope as shown below, and lamp current $I_L = I_{rms}$:(This is temporary measurement method.)

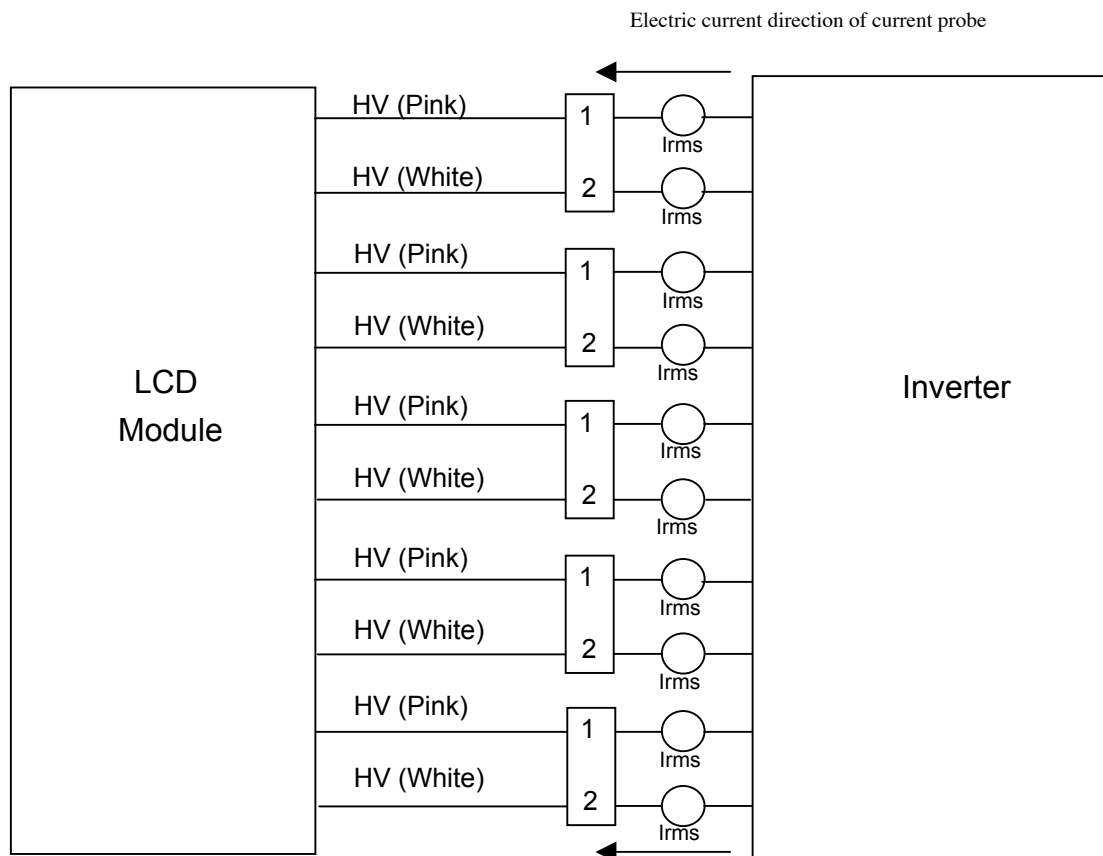

Note (2) The lamp starting voltage V_S should be applied to the lamp for more than 1 second under starting up duration. Otherwise the lamp could not be lighted on completed.

Note (3) The lamp frequency may produce interference with horizontal synchronous frequency of the display input signals, and it may result in line flow on the display. In order to avoid interference, the lamp frequency should be detached from the horizontal synchronous frequency and its harmonics as far as possible.

Note (4) The life time of a lamp is defined as when the brightness is larger than 50% of its original value and the effective discharge length is longer than 80% of its original length (Effective discharge length is defined as an area that has equal to or more than 70% brightness compared to the brightness at the center point of lamp.) as the time in which it continues to operate under the condition at $T_a = 25 \pm 2^\circ\text{C}$ and $I_L = 5.0 \sim 6.0 \text{ mA}_{\text{RMS}}$.

4. BLOCK DIAGRAM

4.1 TFT LCD MODULE

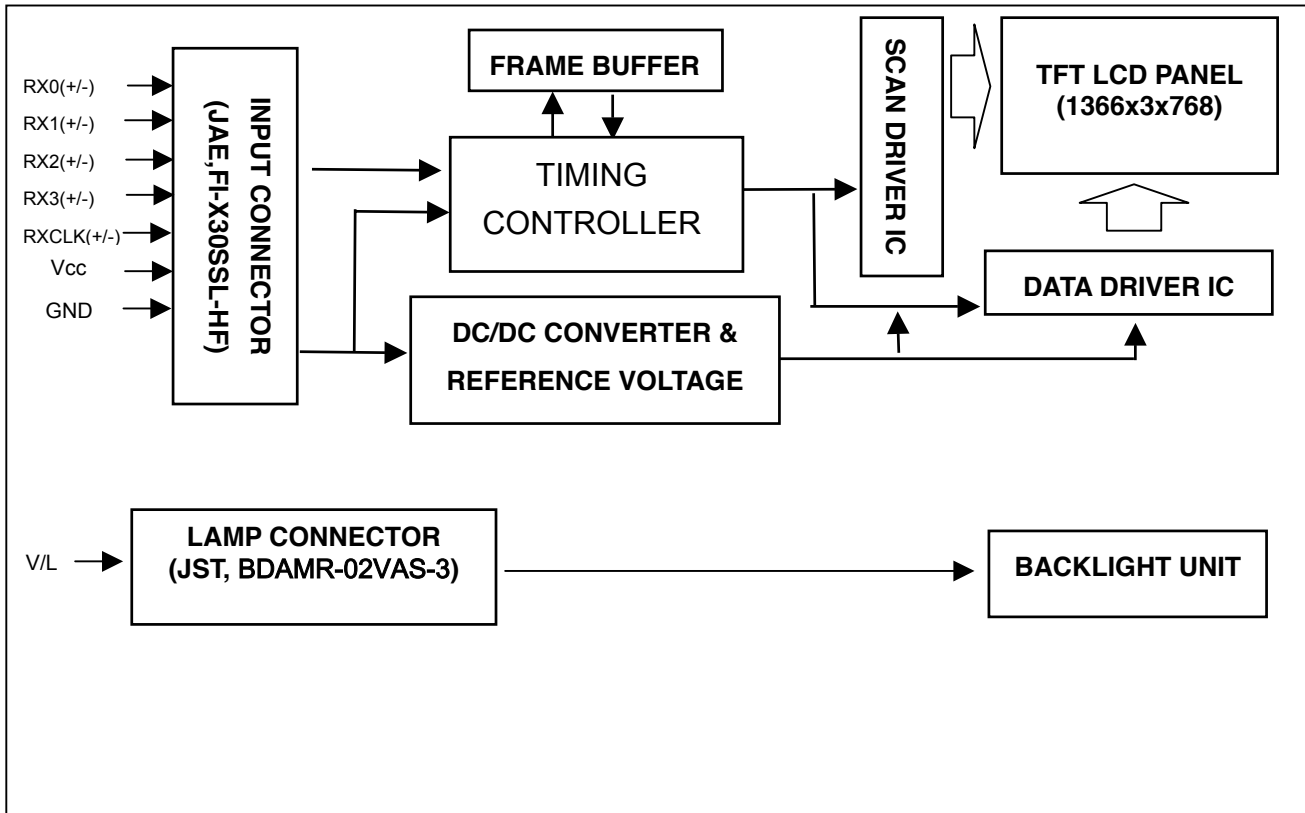

5. INTERFACE PIN CONNECTION

5.1 TFT LCD MODULE

CNF1 Connector Pin Assignment

Pin No.	Symbol	Description	Note
1	NC	No Connection	(2)
2	RPF	Display Rotation	(3)
3	SELLVDS	Select LVDS Data Format	(5)
4	NC	No Connection	(2)
5	NC	No Connection	
6	ODSEL	Overdrive Lookup Table Selection	(4)
7	NC	No Connection	(2)
8	GND	Ground	
9	RX0-	Negative transmission data of pixel 0	
10	RX0+	Positive transmission data of pixel 0	
11	RX1-	Negative transmission data of pixel 1	
12	RX1+	Positive transmission data of pixel 1	
13	RX2-	Negative transmission data of pixel 2	
14	RX2+	Positive transmission data of pixel 2	
15	RXCLK-	Negative of clock	
16	RXCLK+	Positive of clock	
17	RX3-	Negative transmission data of pixel 3	
18	RX3+	Positive transmission data of pixel 3	
19	GND	Ground	
20	NC	No Connection	(2)
21	NC	No Connection	
22	NC	No Connection	
23	NC	No Connection	
24	GND	Ground	
25	GND	Ground	
26	GND	Ground	
27	VCC	Power supply: +5V	
28	VCC	Power supply: +5V	
29	VCC	Power supply: +5V	
30	VCC	Power supply: +5V	

Note (1) Connector Part No.: FI-X30SSL-HF(JAE).

Note (2) Reserved for internal use. Left it open.

Note (3) Low : normal display (default), High : display with 180 degree rotation

Note (4) Overdrive lookup table selection. The Overdrive lookup table should be selected in accordance with the frame rate to optimize image quality.

Note (5) Please refer to 5.4 LVDS INTERFACE (page 13)

ODSEL	Note
L	Lookup table was optimized for 60 Hz frame rate.
H	OD OFF.

5.2 BACKLIGHT UNIT

The pin configuration for the housing and leader wire is shown in the table below.

CN2-CN6 (Housing): BDAMR-02VAS-3 (JST)

Pin No.	Symbol	Description	Wire Color
1	HV	High Voltage	Pink
2	HV	High Voltage	White

Note (1) The backlight interface housing for high voltage side is a model BDAMR-02VAS-3, manufactured by JST.

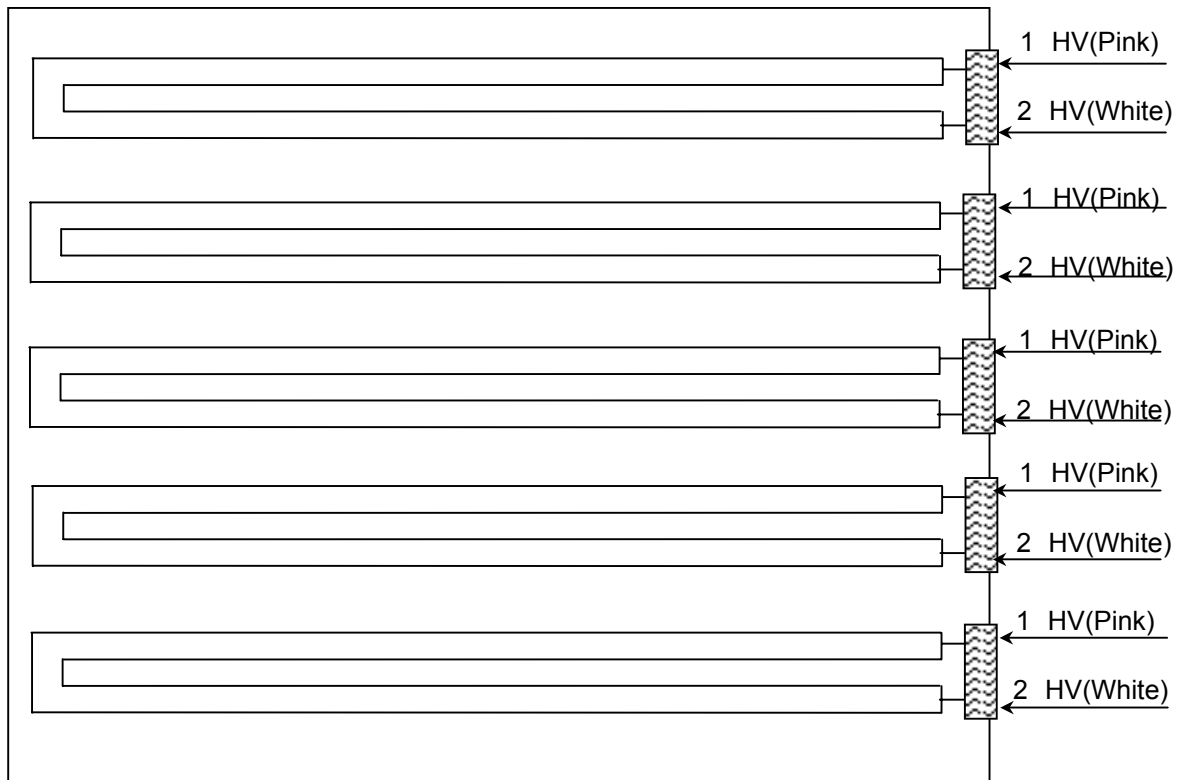

5.3 BLOCK DIAGRAM OF INTERFACE

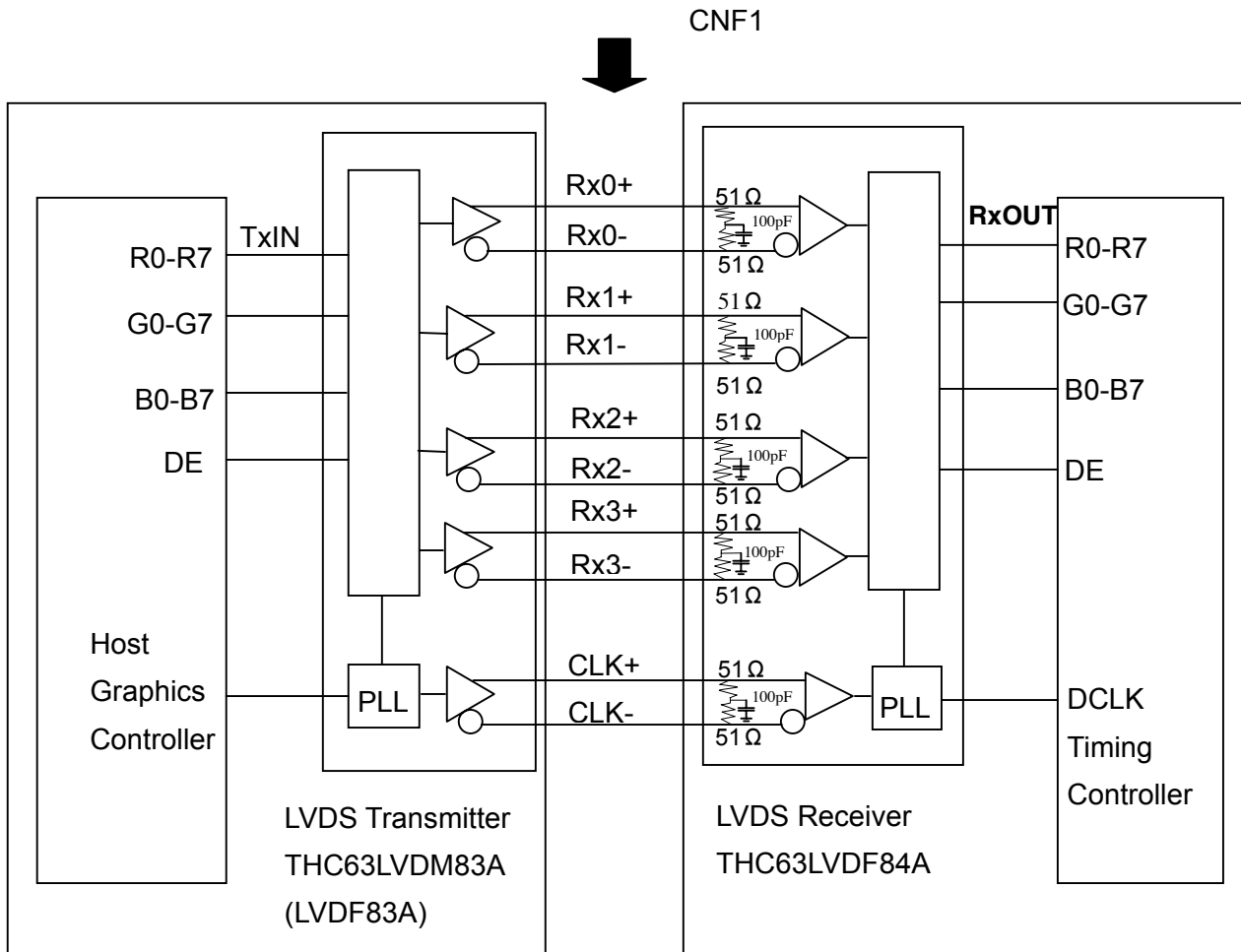

R0~R7 : Pixel R Data ,
 G0~G7 : Pixel G Data ,
 B0~B7 : Pixel B Data ,
 DE : Data enable signal

Note (1) The system must have the transmitter to drive the module.

Note (2) LVDS cable impedance shall be 50 ohms per signal line or about 100 ohms per twist-pair line when it is used differentially.

5.4 LVDS INTERFACE

	SIGNAL		TRANSMITTER THC63LVDM83A		INTERFACE CONNECTOR		RECEIVER THC63LVDF84A		TFT CONTROL INPUT			
	SELLVDS =L or OPEN	SELLVDS =H	PIN	INPUT	Host	TFT-LCD	PIN	OUTPUT	SELLVDS =L or OPEN	SELLVDS =H		
24 bit	R0	R2	51	TxIN0	TA OUT0+	Rx 0+	27	Rx OUT0	R0	R2		
	R1	R3	52	TxIN1			29	Rx OUT1	R1	R3		
	R2	R4	54	TxIN2			30	Rx OUT2	R2	R4		
	R3	R5	55	TxIN3			32	Rx OUT3	R3	R5		
	R4	R6	56	TxIN4			33	Rx OUT4	R4	R6		
	R5	R7	3	TxIN6			TA OUT0-	Rx 0-	35	Rx OUT6	R5	R7
	G0	G2	4	TxIN7			37	Rx OUT7	G0	G2		
	G1	G3	6	TxIN8	38	Rx OUT8	G1	G3				
	G2	G4	7	TxIN9	39	Rx OUT9	G2	G4				
	G3	G5	11	TxIN12	TA OUT1+	Rx 1+	43	Rx OUT12	G3	G5		
	G4	G6	12	TxIN13	45	Rx OUT13	G4	G6				
	G5	G7	14	TxIN14	46	Rx OUT14	G5	G7				
	B0	B2	15	TxIN15	TA OUT1-	Rx 1-	47	Rx OUT15	B0	B2		
	B1	B3	19	TxIN18	51	Rx OUT18	B1	B3				
	B2	B4	20	TxIN19	53	Rx OUT19	B2	B4				
	B3	B5	22	TxIN20	54	Rx OUT20	B3	B5				
	B4	B6	23	TxIN21	TA OUT2+	Rx 2+	55	Rx OUT21	B4	B6		
	B5	B7	24	TxIN22	1	Rx OUT22	B5	B7				
	DE	DE	30	TxIN26	6	Rx OUT26	DE	DE				
	R6	R0	50	TxIN27	TA OUT2-	Rx 2-	7	Rx OUT27	R6	R0		
	R7	R1	2	TxIN5	34	Rx OUT5	R7	R1				
	G6	G0	8	TxIN10	41	Rx OUT10	G6	G0				
	G7	G1	10	TxIN11	42	Rx OUT11	G7	G1				
	B6	B0	16	TxIN16	TA OUT3+	Rx 3+	49	Rx OUT16	B6	B0		
	B7	B1	18	TxIN17	50	Rx OUT17	B7	B1				
RSVD 1	RSVD 1	25	TxIN23	2	Rx OUT23	NC	NC					
RSVD 2	RSVD 2	27	TxIN24	TA OUT3-	Rx 3-	3	Rx OUT24	NC	NC			
RSVD 3	RSVD 3	28	TxIN25	5	Rx OUT25	NC	NC					
DCLK			31	TxCLK IN	TxCLK OUT+	RxCLK IN+	26	RxCLK OUT	DCLK			
					TxCLK OUT-	RxCLK IN-						

R0~R7: Pixel R Data (7; MSB, 0; LSB)

G0~G7: Pixel G Data (7; MSB, 0; LSB)

B0~B7: Pixel B Data (7; MSB, 0; LSB)

DE: Data enable signal

Notes(1) RSVD(reserved)pins on the transmitter shall be "H" or("L" or OPEN)

5.5 COLOR DATA INPUT ASSIGNMENT

The brightness of each primary color (red, green and blue) is based on the 8-bit gray scale data input for the color. The higher the binary input, the brighter the color. The table below provides the assignment of color versus data input.

Color		Data Signal																							
		Red								Green								Blue							
		R7	R6	R5	R4	R3	R2	R1	R0	G7	G6	G5	G4	G3	G2	G1	G0	B7	B6	B5	B4	B3	B2	B1	B0
Basic Colors	Black	0	0	0	0	0	0	0	0	0	0	0	0	0	0	0	0	0	0	0	0	0	0	0	
	Red	1	1	1	1	1	1	1	1	0	0	0	0	0	0	0	0	0	0	0	0	0	0	0	
	Green	0	0	0	0	0	0	0	0	1	1	1	1	1	1	1	1	0	0	0	0	0	0	0	
	Blue	0	0	0	0	0	0	0	0	0	0	0	0	0	0	0	1	1	1	1	1	1	1	1	
	Cyan	0	0	0	0	0	0	0	0	1	1	1	1	1	1	1	1	1	1	1	1	1	1	1	
	Magenta	1	1	1	1	1	1	1	1	0	0	0	0	0	0	0	0	1	1	1	1	1	1	1	
	Yellow	1	1	1	1	1	1	1	1	1	1	1	1	1	1	1	1	0	0	0	0	0	0	0	
	White	1	1	1	1	1	1	1	1	1	1	1	1	1	1	1	1	1	1	1	1	1	1	1	
Gray Scale Of Red	Red(0) / Dark	0	0	0	0	0	0	0	0	0	0	0	0	0	0	0	0	0	0	0	0	0	0		
	Red(1)	0	0	0	0	0	0	0	1	0	0	0	0	0	0	0	0	0	0	0	0	0	0		
	Red(2)	0	0	0	0	0	0	1	0	0	0	0	0	0	0	0	0	0	0	0	0	0	0		
	:	:	:	:	:	:	:	:	:	:	:	:	:	:	:	:	:	:	:	:	:	:	:		
	:	:	:	:	:	:	:	:	:	:	:	:	:	:	:	:	:	:	:	:	:	:	:		
	Red(253)	1	1	1	1	1	1	0	1	0	0	0	0	0	0	0	0	0	0	0	0	0	0		
	Red(254)	1	1	1	1	1	1	1	0	0	0	0	0	0	0	0	0	0	0	0	0	0	0		
	Red(255)	1	1	1	1	1	1	1	1	0	0	0	0	0	0	0	0	0	0	0	0	0	0		
Gray Scale Of Green	Green(0) / Dark	0	0	0	0	0	0	0	0	0	0	0	0	0	0	0	0	0	0	0	0	0	0		
	Green(1)	0	0	0	0	0	0	0	0	0	0	0	0	0	0	1	0	0	0	0	0	0	0		
	Green(2)	0	0	0	0	0	0	0	0	0	0	0	0	0	1	0	0	0	0	0	0	0	0		
	:	:	:	:	:	:	:	:	:	:	:	:	:	:	:	:	:	:	:	:	:	:	:		
	:	:	:	:	:	:	:	:	:	:	:	:	:	:	:	:	:	:	:	:	:	:	:		
	Green(253)	0	0	0	0	0	0	0	0	1	1	1	1	1	1	0	1	0	0	0	0	0	0		
	Green(254)	0	0	0	0	0	0	0	0	1	1	1	1	1	1	1	0	0	0	0	0	0	0		
	Green(255)	0	0	0	0	0	0	0	0	1	1	1	1	1	1	1	1	0	0	0	0	0	0		
Gray Scale Of Blue	Blue(0) / Dark	0	0	0	0	0	0	0	0	0	0	0	0	0	0	0	0	0	0	0	0	0	0		
	Blue(1)	0	0	0	0	0	0	0	0	0	0	0	0	0	0	0	0	0	0	0	0	0	1		
	Blue(2)	0	0	0	0	0	0	0	0	0	0	0	0	0	0	0	0	0	0	0	0	0	1		
	:	:	:	:	:	:	:	:	:	:	:	:	:	:	:	:	:	:	:	:	:	:	:		
	:	:	:	:	:	:	:	:	:	:	:	:	:	:	:	:	:	:	:	:	:	:	:		
	Blue(253)	0	0	0	0	0	0	0	0	0	0	0	0	0	0	0	1	1	1	1	1	1	0		
	Blue(254)	0	0	0	0	0	0	0	0	0	0	0	0	0	0	0	1	1	1	1	1	1	0		
	Blue(255)	0	0	0	0	0	0	0	0	0	0	0	0	0	0	0	1	1	1	1	1	1	1		

Note (1) 0: Low Level Voltage, 1: High Level Voltage

6. INTERFACE TIMING

6.1 INPUT SIGNAL TIMING SPECIFICATIONS

The input signal timing specifications are shown as the following table and timing diagram.

Signal	Item	Symbol	Min.	Typ.	Max.	Unit	Note
LVDS Receiver Clock	Frequency	1/Tc	65	86	88	MHz	
	Input cycle to cycle Jitter	Trcl	-	-	200	ps	
LVDS Receiver Data	Setup Time	Tlvsu	600	-	-	ps	
	Hold Time	Tlvhd	600	-	-	ps	
Vertical Active Display Term	Frame Rate	Fr5	47	50	53	Hz	
		Fr6	57	60	63	Hz	
	Total	Tv	778	795	888	Th	Tv=Tvd+Tvb
	Display	Tvd	768	768	768	Th	-
	Blank	Tvb	10	27	120	Th	-
Horizontal Active Display Term	Total	Th	1436	1798	1936	Tc	Th=Thd+Thb
	Display	Thd	1366	1366	1366	Tc	-
	Blank	Thb	70	432	570	Tc	-

Note (1) Since this module is operated in DE only mode, Hsync and Vsync input signals should be set to low logic level. Otherwise, this module would operate abnormally.

(2) Please refer to 5.1 for detail information.

INPUT SIGNAL TIMING DIAGRAM

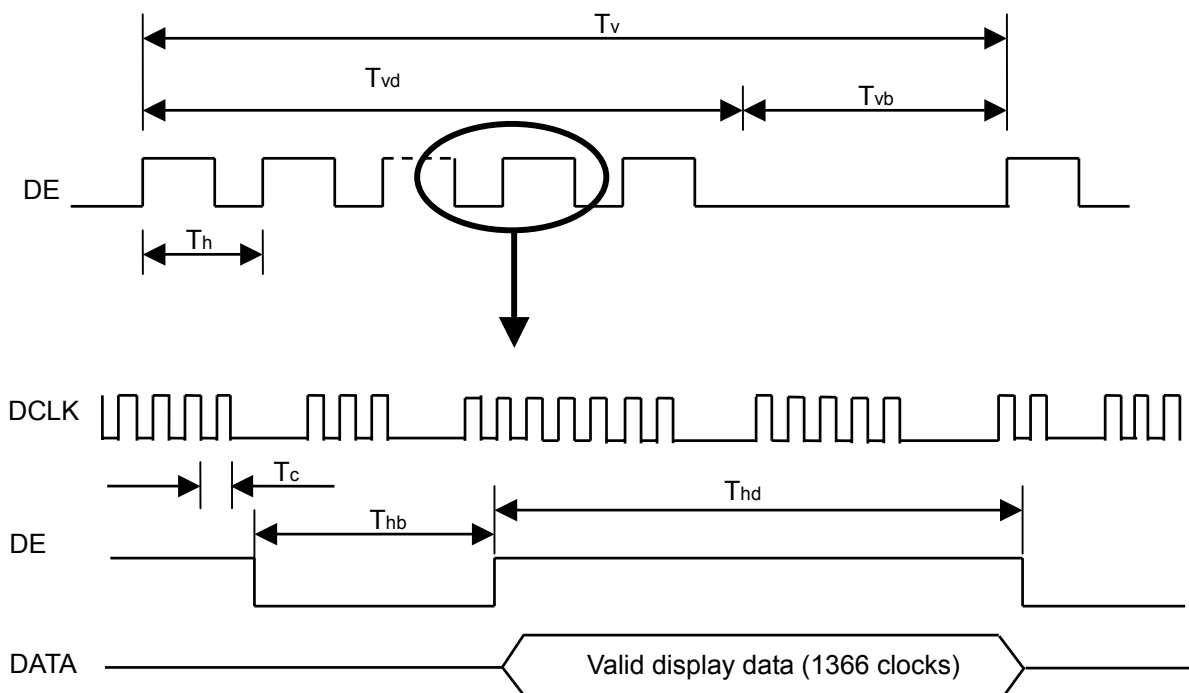

LVDS RECEIVER INTERFACE TIMING DIAGRAM

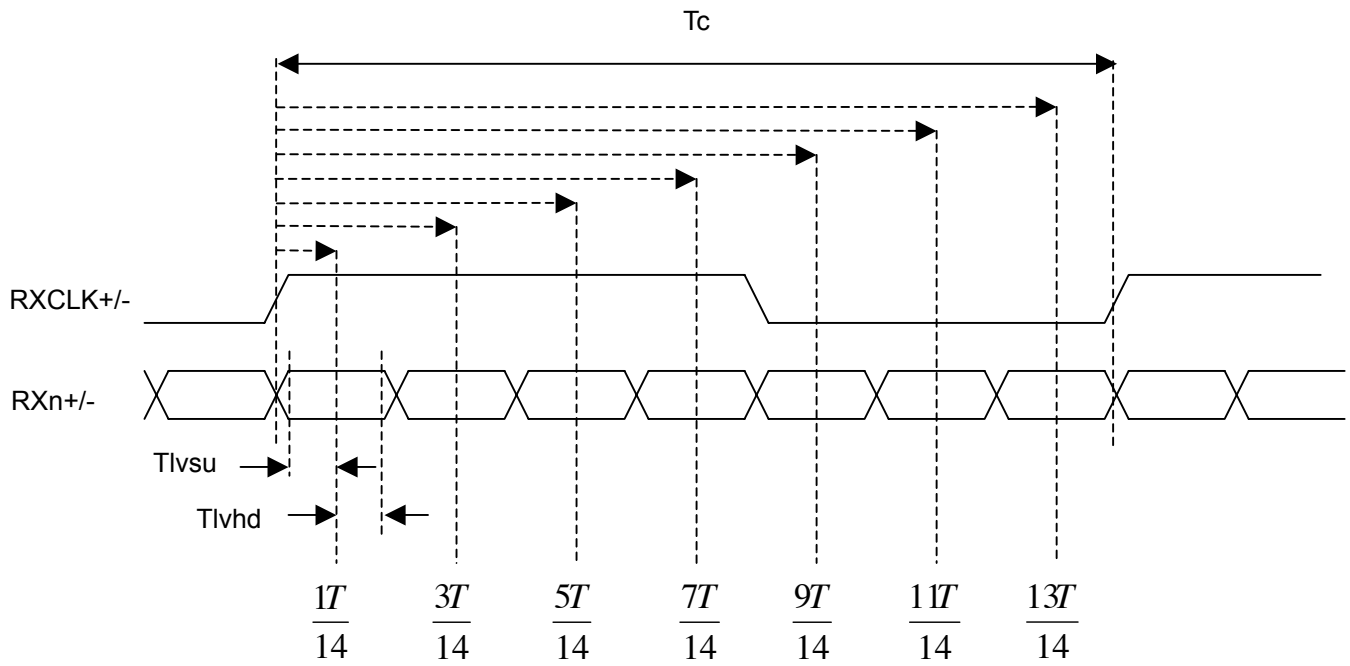

6.2 POWER ON/OFF SEQUENCE

To prevent a latch-up or DC operation of LCD module, the power on/off sequence should be as the diagram below.

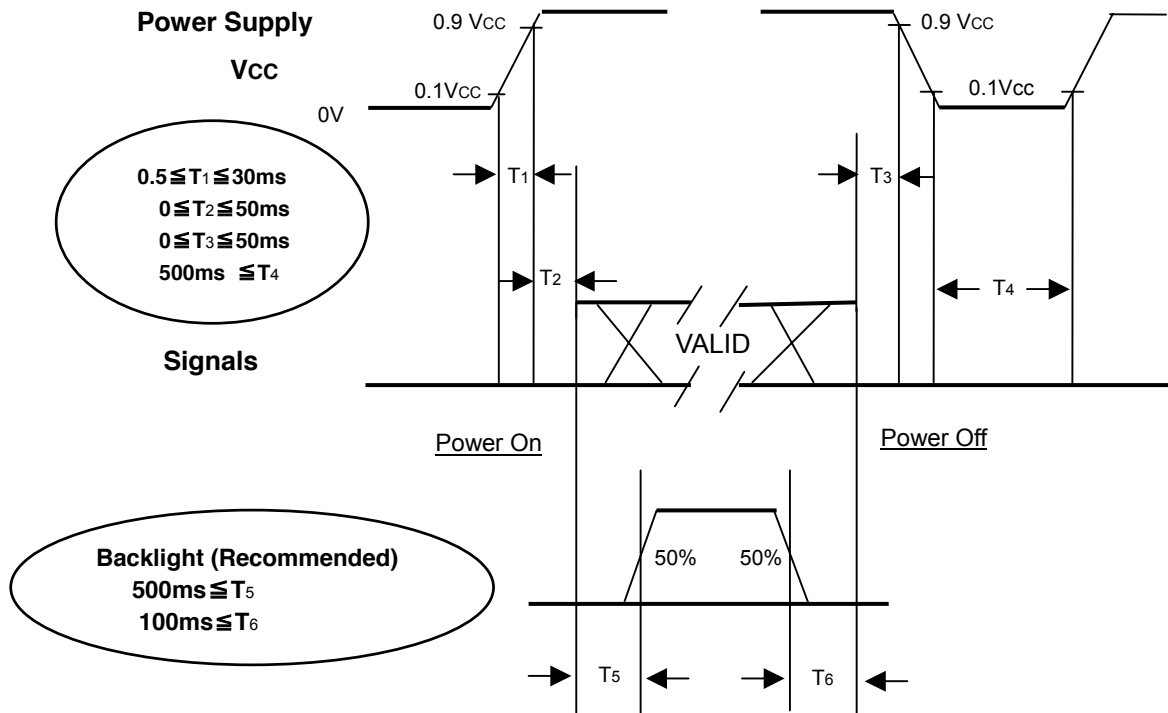

Power ON/OFF Sequence

- Note (1) The supply voltage of the external system for the module input should follow the definition of Vcc.
- Note (2) Apply the lamp voltage within the LCD operation range. When the backlight turns on before the LCD operation or the LCD turns off before the backlight turns off, the display may momentarily become abnormal screen.
- Note (3) In case of Vcc is in off level, please keep the level of input signals on the low or high impedance.
- Note (4) T4 should be measured after the module has been fully discharged between power off and on period.
- Note (5) Interface signal shall not be kept at high impedance when the power is on.

7. OPTICAL CHARACTERISTICS

7.1 TEST CONDITIONS

Item	Symbol	Value	Unit
Ambient Temperature	Ta	25±2	°C
Ambient Humidity	Ha	50±10	%RH
Supply Voltage	V _{CC}	5.0	V
Input Signal	According to typical value in "3. ELECTRICAL CHARACTERISTICS"		
Lamp Current	I _L	5.3	mA
Oscillating Frequency (Inverter)	F _W	60 ± 5	KHz
Frame Rate	Fr	60	Hz

Note(1) Luminance is judged by golden inverter.

7.2 OPTICAL SPECIFICATIONS

The relative measurement methods of optical characteristics are shown in 7.2. The following items should be measured under the test conditions described in 7.1 and stable environment shown in Note (6).

Item		Symbol	Condition	Min.	Typ.	Max.	Unit	Note	
Contrast Ratio		CR	Viewing Angle at Normal Direction $\theta_x=0^\circ, \theta_y=0^\circ$	800	1000	-	-	(2)	
Response Time		Gray to gray average		-	8	16	ms	(3)	
Center Luminance of White		L _C		420	500	-	cd/m ²	(4)	
Average Luminance of White		L _{AVE}		420	500	-	cd/m ²		
White Variation		δW		-	-	1.3	-	(7)	
Cross Talk		CT		-	-	4.0	%	(5)	
Color Chromaticity	Red	R _x		Typ. -0.03	0.649	Typ. +0.03	-	-	(6)
		R _y							
	Green	G _x							
		G _y							
	Blue	B _x							
		B _y							
	White	W _x							
W _y									
Color Gamut		CG	72	75	-	%	NTSC		
Viewing Angle	Horizontal	θ_{x+}	CR≥20	80	88	-	Deg.	(1)	
		θ_{x-}							
	Vertical	θ_{y+}							
		θ_{y-}							

Note (1) Definition of Viewing Angle (θ_x, θ_y):

Viewing angles are measured by EZ-Contrast 160R (Eldim)

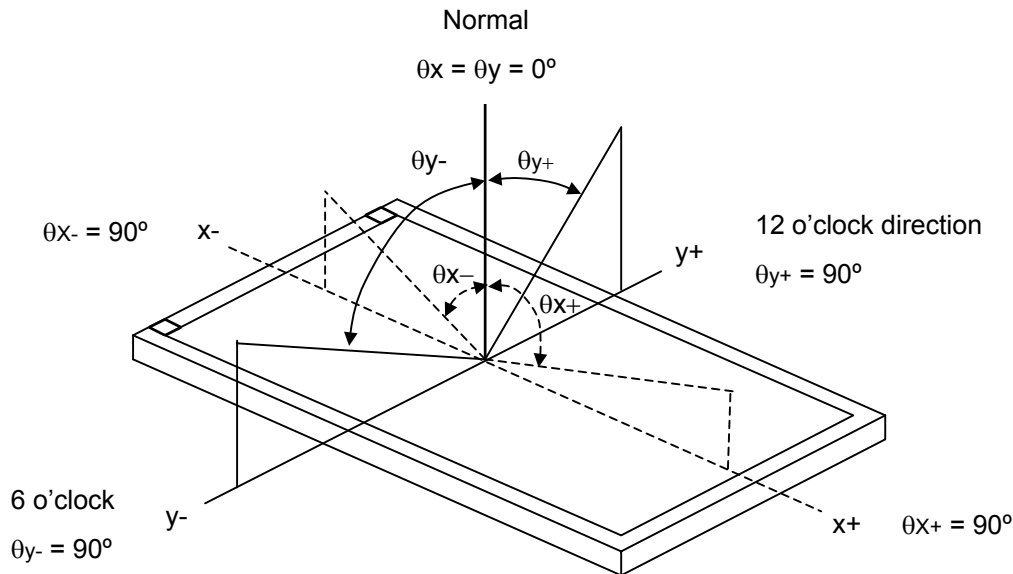

Note (2) Definition of Contrast Ratio (CR):

The contrast ratio can be calculated by the following expression.

$$\text{Contrast Ratio (CR)} = L_{255} / L_0$$

L255: Luminance of gray level 255

L 0: Luminance of gray level 0

$$CR = CR (5)$$

CR (X) is corresponding to the Contrast Ratio of the point X at the figure in Note (7).

Note (3) Definition of Gray to Gray Switching Time :

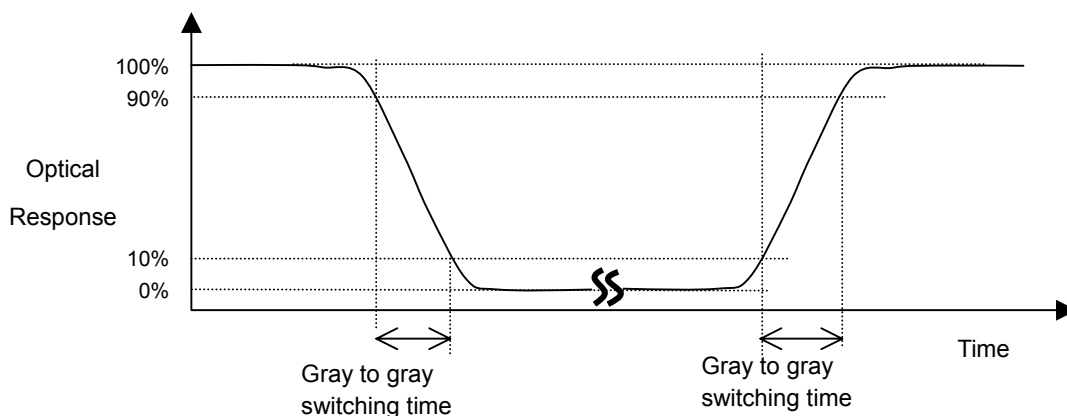

The driving signal means the signal of gray level 0, 63, 127, 191, 255.

Gray to gray average time means the average switching time of gray level 0, 63, 127, 191, 255 to each other.

Note (4) Definition of Luminance of White (L_C , L_{AVE}):

Measure the luminance of gray level 255 at center point and 5 points

$$L_C = L(5)$$

$$L_{AVE} = [L(1) + L(2) + L(3) + L(4) + L(5)] / 5$$

$L(x)$ is corresponding to the luminance of the point X at the figure in Note (7).

Note (5) Definition of Cross Talk (CT):

$$CT = |Y_B - Y_A| / Y_A \times 100 (\%)$$

Where:

Y_A = Luminance of measured location without gray level 0 pattern (cd/m^2)

Y_B = Luminance of measured location with gray level 0 pattern (cd/m^2)

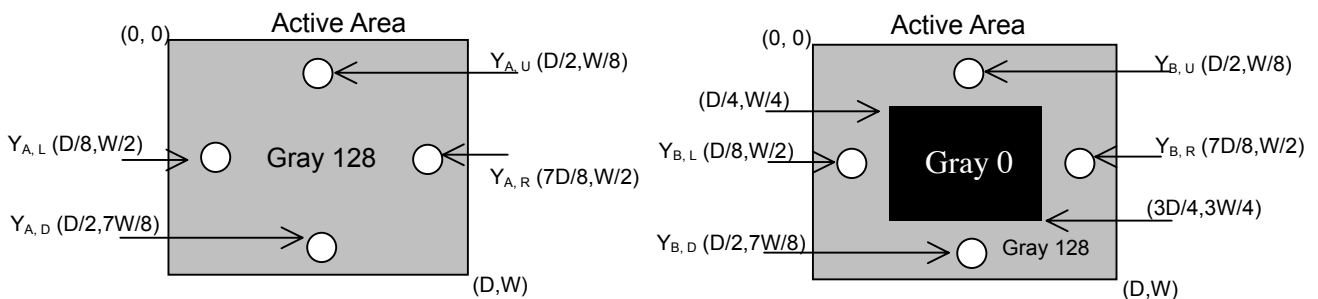

Note (6) Measurement Setup:

The LCD module should be stabilized at given temperature for 1 hour to avoid abrupt temperature change during measuring. In order to stabilize the luminance, the measurement should be executed after lighting Backlight for 1 hour in a windless room.

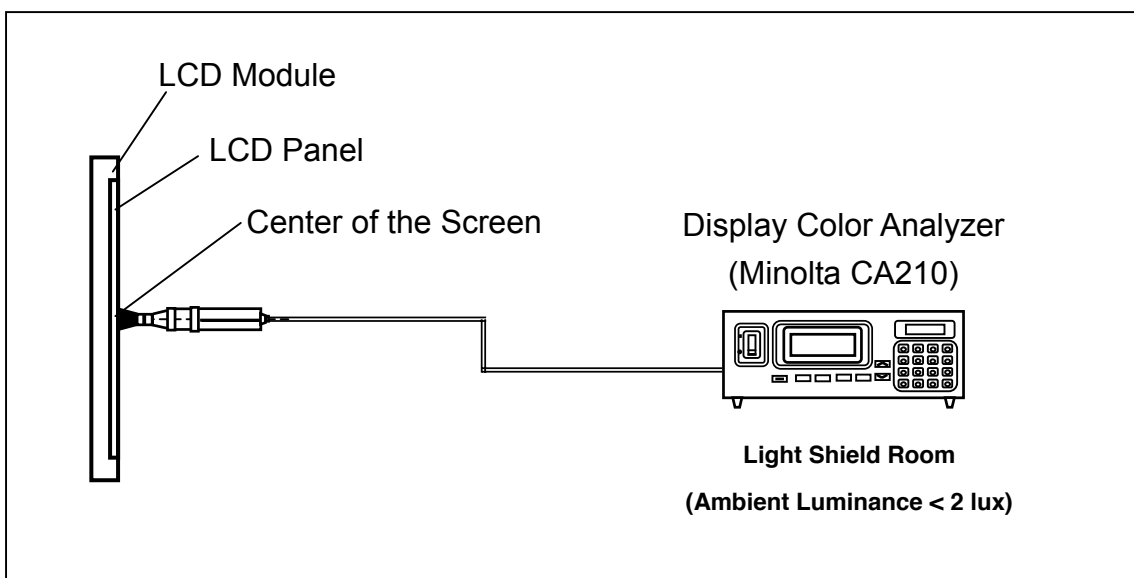

Note (7) Definition of White Variation (δW):

Measure the luminance of gray level 255 at 5 points

$$\delta W = \text{Maximum [L (1), L (2), L (3), L (4), L (5)]} / \text{Minimum [L (1), L (2), L (3), L (4), L (5)]}$$

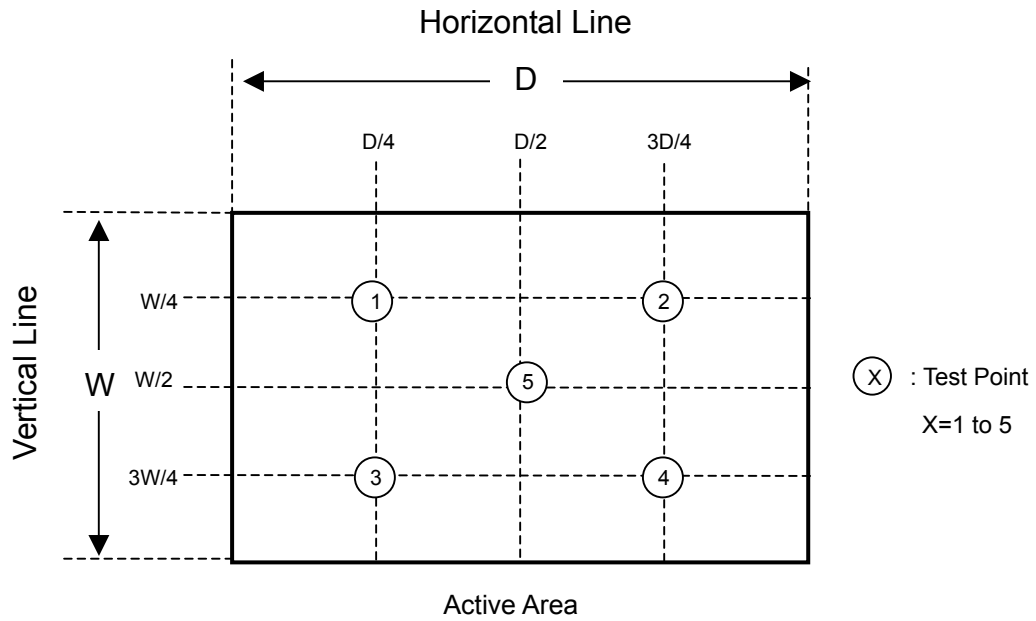

8. DEFINITION OF LABELS

8.1 CMO MODULE LABEL

The barcode nameplate is pasted on each module as illustration, and its definitions are as following explanation.

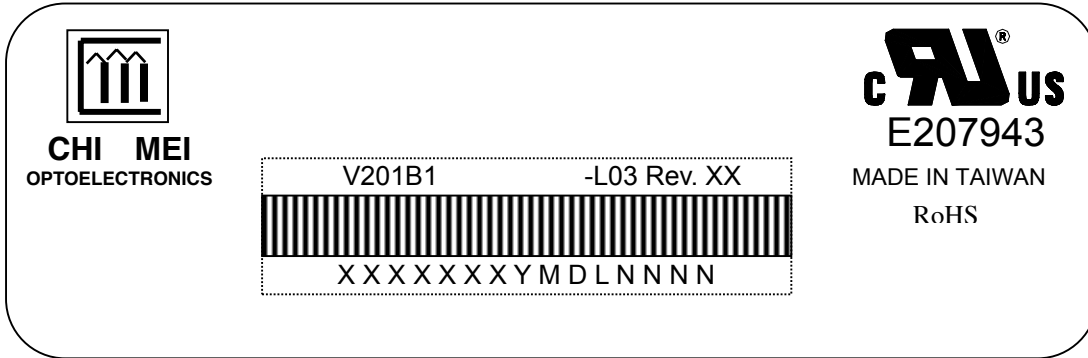

- (a) Model Name: V201B1-L03
- (b) Revision: Rev. XX, for example: A0, A1... B1, B2... or C1, C2...etc.
- (c) Serial ID: XXXXXXXXYMDLNNNN

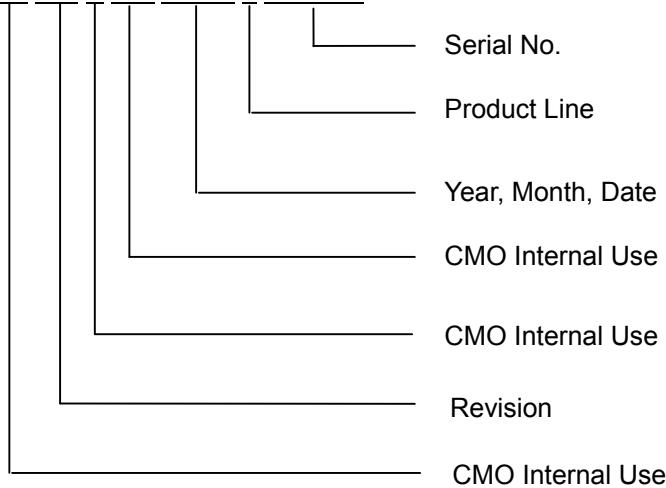

Serial ID includes the information as below:

- (a) Manufactured Date: Year: 0~9, for 2000~2009
 Month: 1~9, A~C, for Jan. ~ Dec.
 Day: 1~9, A~Y, for 1st to 31st, exclude I ,O, and U.
- (b) Revision Code: Cover all the change
- (c) Serial No.: Manufacturing sequence of product
- (d) Product Line: 1 -> Line1, 2 -> Line 2, ...etc.

9. PACKAGING

9.1 PACKING SPECIFICATIONS

- (1) 5 LCD TV modules / 1 Box
- (2) Box dimensions : 566(L) X 428 (W) X 387 (H)
- (3) Weight : approximately 11.5Kg (5 modules per box)

9.2 PACKING METHOD

Figures 9-1 and 9-2 are the packing method

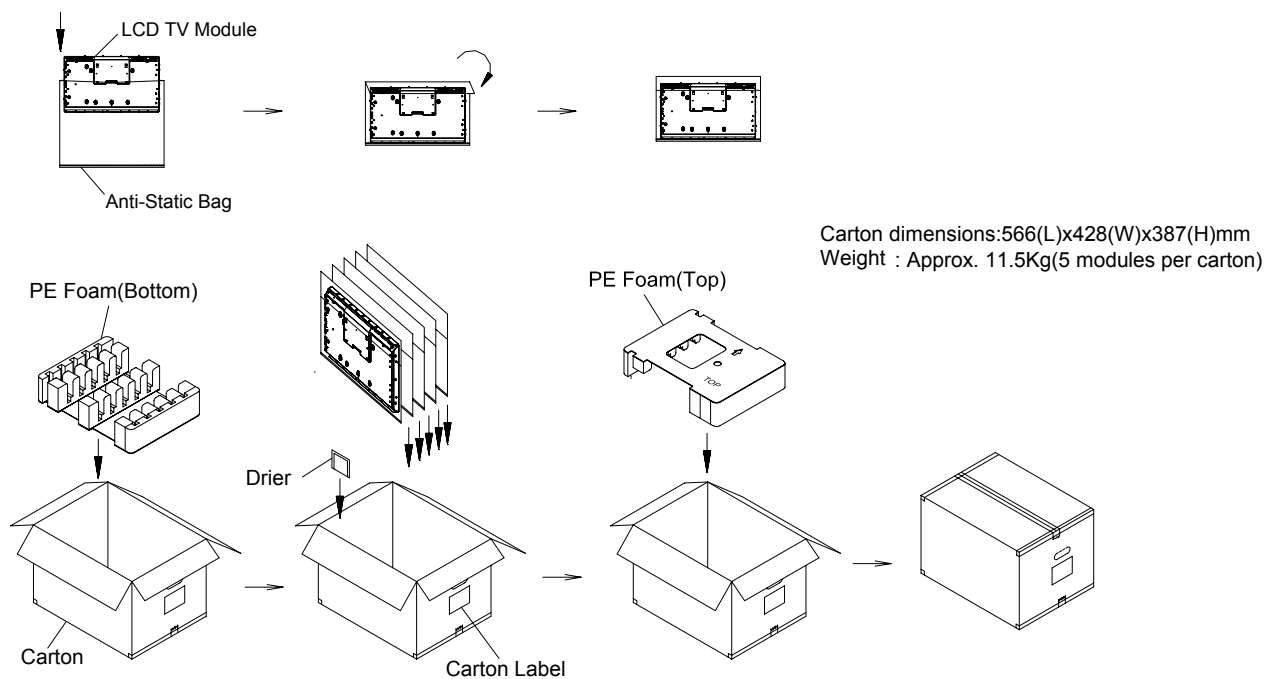
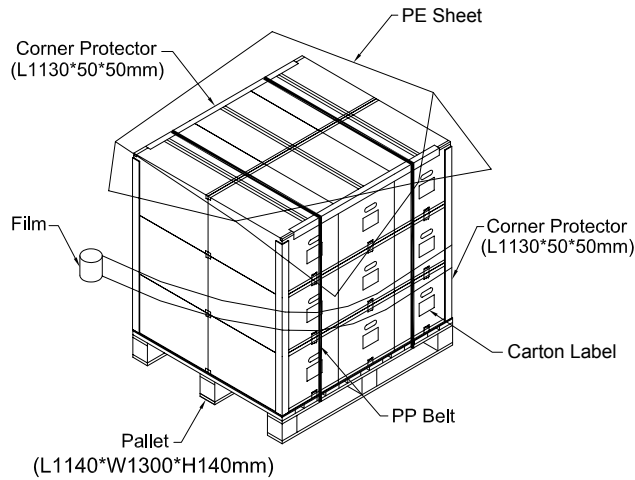

Figure.9-1 packing method

Air Transportation



Pallet:1140(L)*1300(W)*140(H)mm
Pallet Stack:1140(L)*1300(W)*1301(H) mm
Box Qty: 2*3*3=18box/pallet
Gross:224kg

Sea/Land Transportation

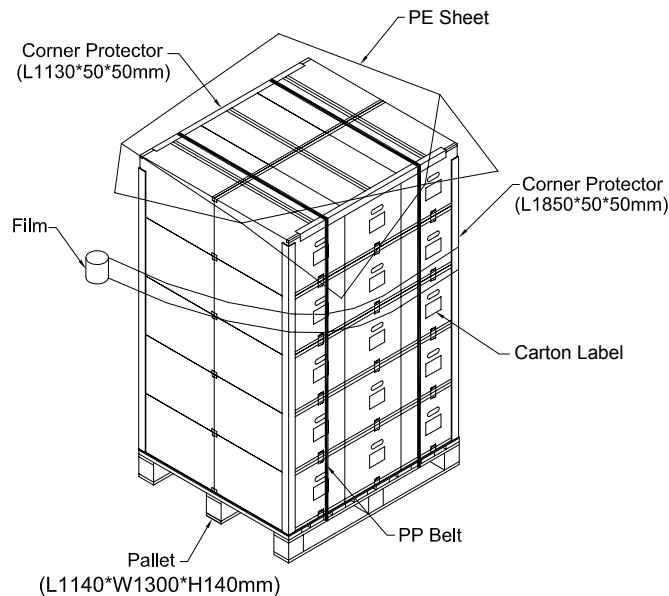

Pallet:1140(L)*1300(W)*140(H)mm
Pallet Stack:1140(L)*1300(W)*2075(H) mm
Box Qty: 2*3*5=30box/pallet
Gross:362kg

Figure. 9-2 packing method

10. PRECAUTIONS

10.1 ASSEMBLY AND HANDLING PRECAUTIONS

- (1) Do not apply rough force such as bending or twisting to the module during assembly.
- (2) It is recommended to assemble or to install a module into the user's system in clean working areas. The dust and oil may cause electrical short or worsen the polarizer.
- (3) Do not apply pressure or impulse to the module to prevent the damage of LCD panel and backlight.
- (4) Always follow the correct power-on sequence when the LCD module is turned on. This can prevent the damage and latch-up of the CMOS LSI chips.
- (5) Do not plug in or pull out the I/F connector while the module is in operation.
- (6) Do not disassemble the module.
- (7) Use a soft dry cloth without chemicals for cleaning, because the surface of polarizer is very soft and easily scratched.
- (8) Moisture can easily penetrate into LCD module and may cause the damage during operation.
- (9) High temperature or humidity may deteriorate the performance of LCD module. Please store LCD modules in the specified storage conditions.
- (10) When ambient temperature is lower than 10°C, the display quality might be reduced. For example, the response time will become slow, and the starting voltage of CCFL will be higher than that of room temperature.

10.2 SAFETY PRECAUTIONS

- (1) The startup voltage of a backlight is over 1000 Volts. It may cause an electrical shock while assembling with the inverter. Do not disassemble the module or insert anything into the backlight unit.
- (2) If the liquid crystal material leaks from the panel, it should be kept away from the eyes or mouth. In case of contact with hands, skin or clothes, it has to be washed away thoroughly with soap.
- (3) After the module's end of life, it is not harmful in case of normal operation and storage.

11. MECHANICAL CHARACTERISTICS

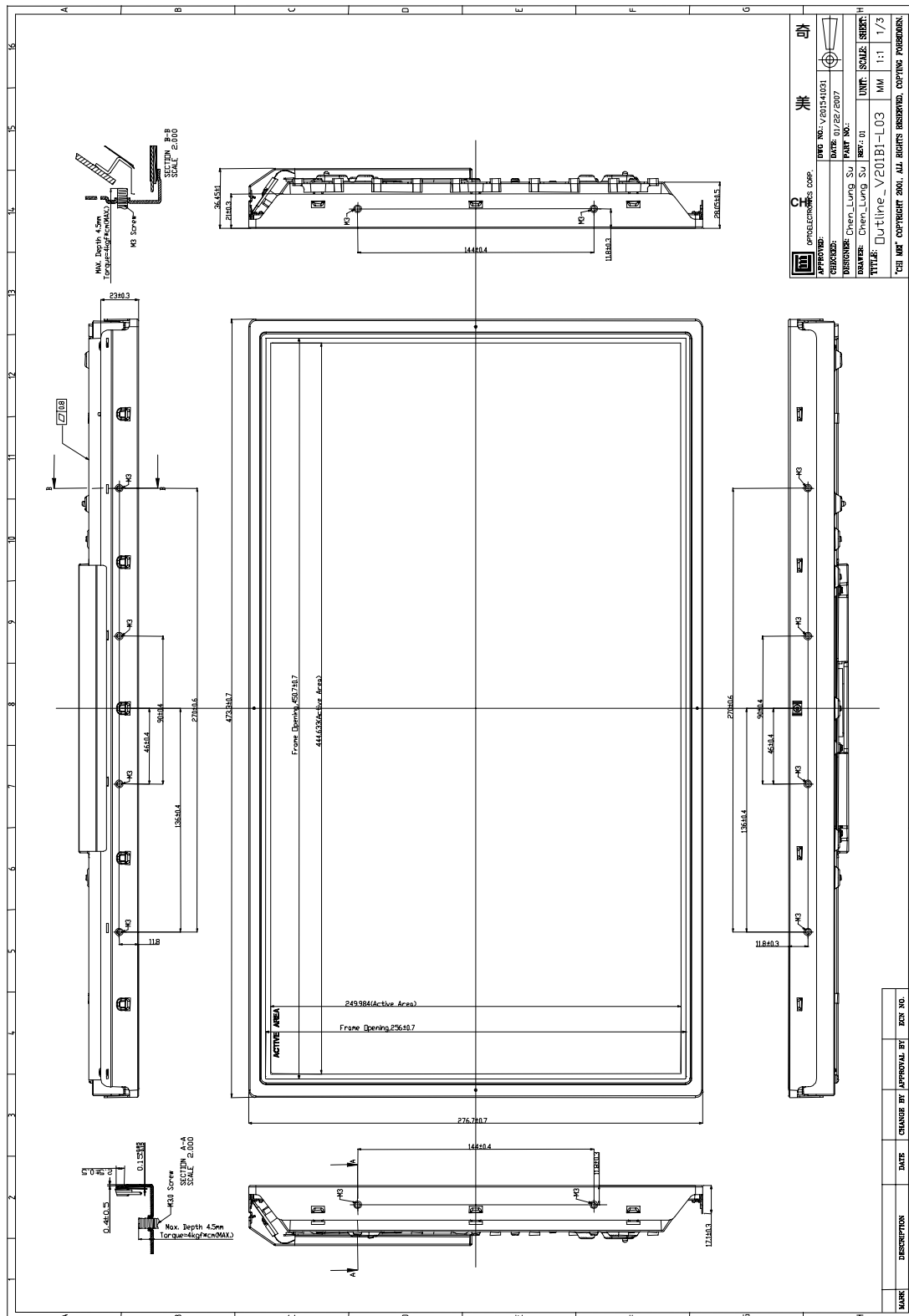

APPROVED:	CHI MEI OPTOELECTRONICS CORP.
DESIGNER:	Chen_Liang_Su
DRAWER:	Chen_Liang_Su
TITLE:	Outline_V201B1-L03
DATE:	01/22/2007
UNIT:	MM
SCALE:	1:1
SHEET:	1/3
FIG. NO.:	V201B1-L03

MARK	DESCRIPTION	DATE	CHANGE BY	APPROVAL BY	REV. NO.

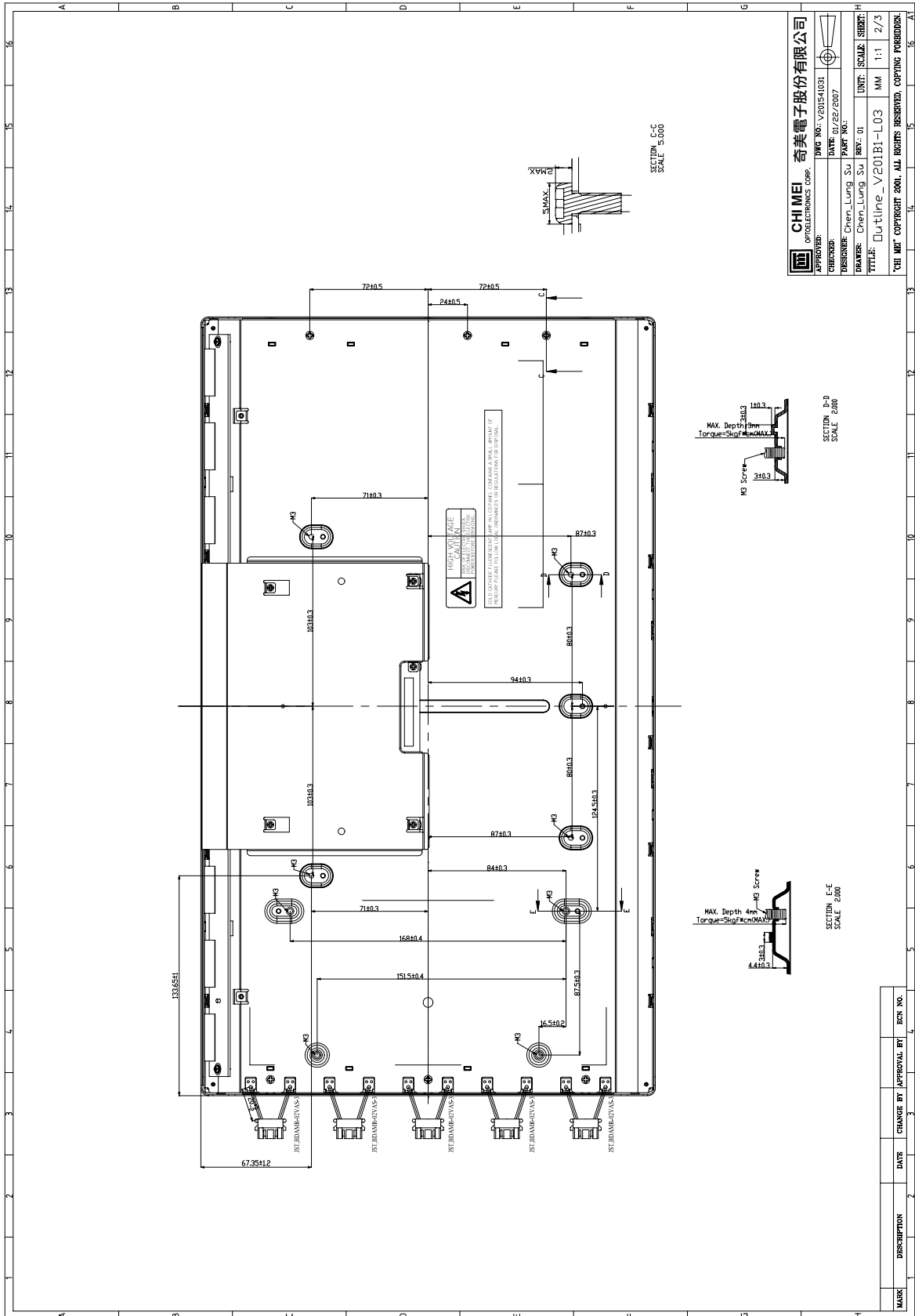

CHI MEI OPTOELECTRONICS CORP.	
APPROVED:	DWG NO.: V201B1-L03
CHECKED:	DATE: 07/22/2007
DESIGNER: Chen_Lung Su	PAID NO.:
DRAWER: Chen_Lung Su	REV.: 01
TITLE: Outline_V201B1-L03	UNIT: SCALE: SHEET: H
	MM 1:1 2/3
"CHI MEI" COPYRIGHT 2001. ALL RIGHTS RESERVED. COPYING FORBIDDEN.	

SECTION D-D
SCALE: 2:00

SECTION E-E
SCALE: 2:00

SECTION C-C
SCALE: 15:000

MARK	DISCUSSION	DATE	CHANGE BY	APPROVAL BY	SCH. NO.

