

TFT LCD Preliminary Specification

MODEL NO.: V201V1-T03

- CONTENTS -

REVISION HISTORY	-----	3
1. GENERAL DESCRIPTION	-----	4
1.1 OVERVIEW		
1.2 FEATURES		
1.3 APPLICATION		
1.4 GENERAL SPECIFICATIONS		
1.5 MECHANICAL SPECIFICATIONS		
2. ABSOLUTE MAXIMUM RATINGS	-----	5
2.1 ABSOLUTE RATINGS OF ENVIRONMENT		
2.2 ELECTRICAL ABSOLUTE RATINGS		
2.2.1 TFT LCD MODULE		
2.2.2 BACKLIGHT UNIT		
3. ELECTRICAL CHARACTERISTICS	-----	6
3.1 TFT LCD MODULE		
3.2 BACKLIGHT UNIT		
4. BLOCK DIAGRAM	-----	10
4.1 TFT LCD MODULE		
4.2 BACKLIGHT UNIT		
5. INPUT TERMINAL PIN ASSIGNMENT	-----	11
5.1 TFT LCD MODULE		
5.2 BACKLIGHT UNIT		
5.3 COLOR DATA INPUT ASSIGNMENT		
6. INTERFACE TIMING	-----	13
6.1 INPUT SIGNAL TIMING SPECIFICATIONS		
6.2 POWER ON/OFF SEQUENCE		
7. OPTICAL CHARACTERISTICS	-----	15
7.1 TEST CONDITIONS		
7.2 OPTICAL SPECIFICATIONS		
8. PACKAGING	-----	19
8.1 PACKING SPECIFICATIONS		
8.1 PACKING METHOD		
9. DEFINITION OF LABELS	-----	21
9.1 CMO MODULE LABEL		
10. PRECAUTIONS	-----	22
10.1 ASSEMBLY AND HANDLING PRECAUTIONS		
10.2 SAFETY PRECAUTIONS		
11. MECHANICAL CHARACTERISTICS	-----	23

REVISION HISTORY

Version	Date	Page (New)	Section	Description
Ver 1.0	May 16, 2005	All	All	Preliminary Specification was first issued.

1. GENERAL DESCRIPTION

1.1 OVERVIEW

V201V1- T03 is a 20.1" TFT Liquid Crystal Display module with 6-CCFL Backlight unit and 1ch-TTL interface. This module supports 640 x 480 VGA format.

1.2 FEATURES

- High brightness (500 nits)
- High contrast ratio (500:1)
- Fast response time (8ms)
- High color saturation NTSC 75%
- VGA (640 x 480 pixels) resolution
- DE (Data Enable) only mode
- TTL interface
- Power consumption is under 40 W

1.3 APPLICATION

- TFT LCD TVs

1.4 GENERAL SPECIFICATIONS

Item	Specification	Unit	Note
Active Area	408 (H) x 306 (V) (20.1" diagonal)	mm	(1)
Bezel Opening Area	412 (H) x 310 (V)	mm	
Driver Element	a-si TFT active matrix	-	-
Pixel Number	640 x R.G.B. x 480	pixel	-
Pixel Pitch(Sub Pixel)	0.2125 (H) x 0.6375 (V)	mm	-
Pixel Arrangement	RGB vertical stripe	-	-
Display Colors	0.26M	color	-
Display Operation Mode	Transmissive mode / Normally white	-	-
Surface Treatment	Anti-glare coating	-	-

1.5 MECHANICAL SPECIFICATIONS

Item	Min.	Typ.	Max.	Unit	Note	
Module Size	Horizontal(H)	447.9	448.6	449.3	mm	(1)
	Vertical(V)	338.9	339.6	340.3	mm	
	Depth(D)	22.6	23.6	24.6	mm	
Weight	3050	3150	3250	g	-	

Note (1) Please refer to the attached drawings for more information of front and back outline dimensions.

2. ABSOLUTE MAXIMUM RATINGS

2.1 ABSOLUTE RATINGS OF ENVIRONMENT

Item	Symbol	Value		Unit	Note
		Min.	Max.		
Storage Temperature	T _{ST}	-20	+60	°C	(1)
Operating Ambient Temperature	T _{OP}	0	50	°C	(1), (2)
Shock (Non-Operating)	S _{NOF}	-	50	G	(3), (5)
Vibration (Non-Operating)	V _{NOF}	-	1.0	G	(4), (5)

Note (1) Temperature and relative humidity range is shown in the figure below.

(a) 90 %RH Max. ($T_a \leq 40$ °C).

(b) Wet-bulb temperature should be 39 °C Max. ($T_a > 40$ °C).

(c) No condensation.

Note (2) The temperature of panel display area surface should be 0 °C Min. and 60 °C Max.

Note (3) 11 ms, half sine wave, 1 time for $\pm X$, $\pm Y$, $\pm Z$.

Note (4) 10 ~ 500 Hz, 10 min, 1 time each X, Y, Z.

Note (5) At testing Vibration and Shock, the fixture in holding the module has to be hard and rigid enough so that the module would not be twisted or bent by the fixture.

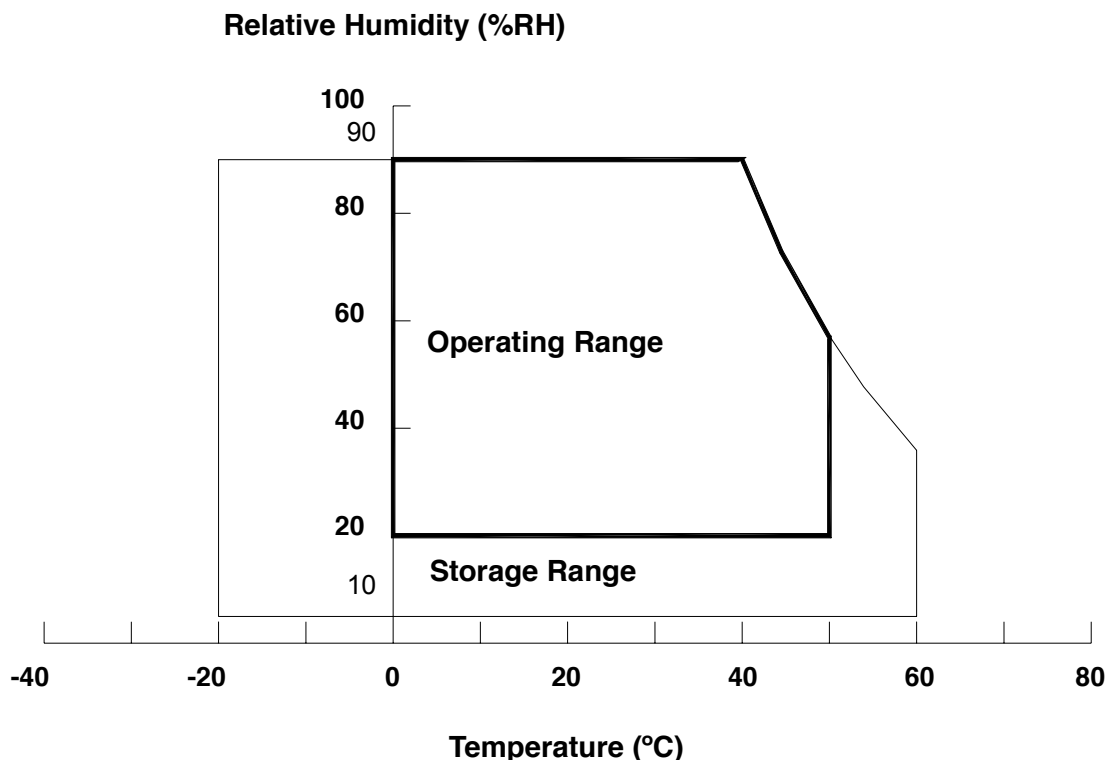

2.2 ELECTRICAL ABSOLUTE RATINGS

2.2.1 TFT LCD MODULE

Item	Symbol	Value		Unit	Note
		Min.	Max.		
Power Supply Voltage	V _{CC}	-0.3	+6.0	V	

2.2.2 BACKLIGHT UNIT

Item	Symbol	Value		Unit	Note
		Min.	Max.		
Lamp Voltage	V _L	-	3000	V _{RMS}	
Lamp Current	I _L	-	7.0	MA _{RMS}	
Lamp Frequency	F _L	20	80	KHz	

3. ELECTRICAL CHARACTERISTICS

3.1 TFT LCD MODULE

T_a = 25 ± 2 °C

Parameter	Symbol	Value			Unit	Note	
		Min.	Typ.	Max.			
Power Supply Voltage	V _{CC}	4.5	5.0	5.5	V	(1)	
Ripple Voltage	V _{RP}	-	80	-	mV	(2)	
Rush Current	I _{RUSH}	-	1.8	-	A		
Power Supply Current	White	I _{CC}	-	0.23	-	A	(3)
	Black		-	0.34	-	A	
	Vertical Stripe		-	0.32	-	A	
TTL input high threshold voltage	V _{IH}	2.3	-	3.3	V		
TTL input low threshold voltage	V _{IL}	0	-	1	V		

Note (1) The module should be always operated within above ranges.

Note (2) Measurement Conditions:

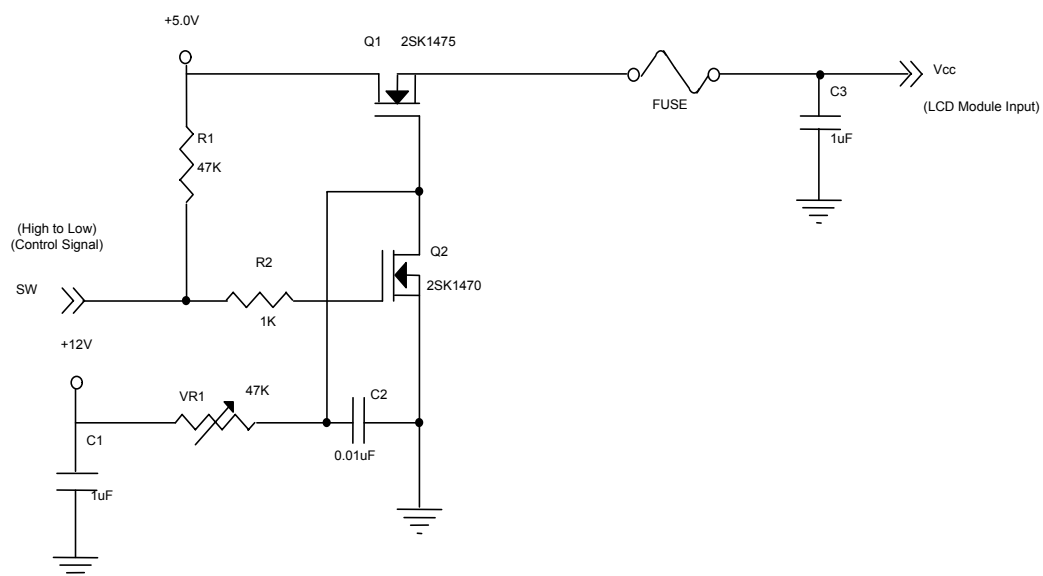

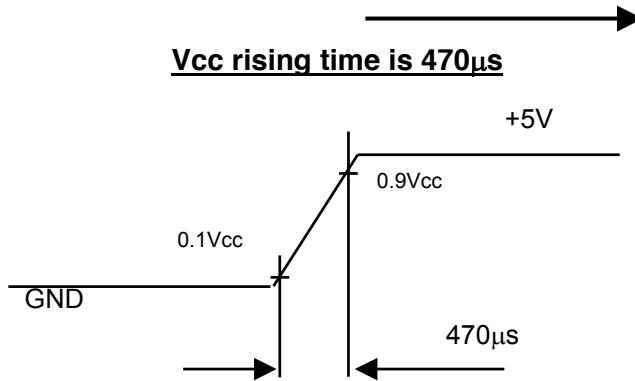

Note (3) The specified power supply current is under the conditions at $V_{cc} = 5\text{ V}$, $T_a = 25 \pm 2\text{ }^\circ\text{C}$, $f_v = 60\text{ Hz}$, whereas a power dissipation check pattern below is displayed.

a. White Pattern

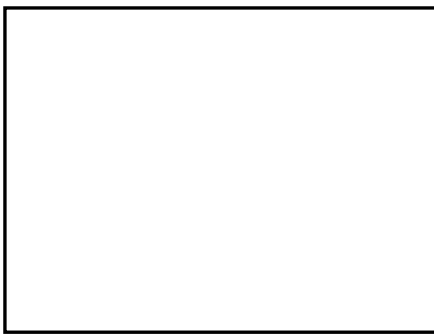

Active Area

b. Black Pattern



Active Area

c. Vertical Stripe Pattern

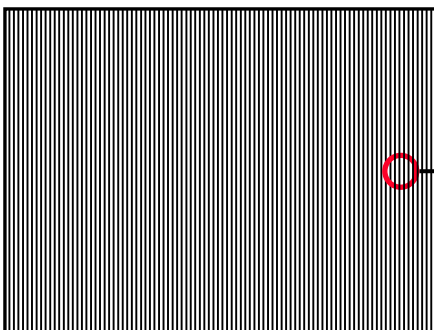

Active Area

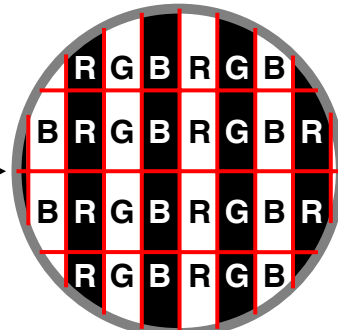

3.2 BACKLIGHT UNIT
 $T_a = 25 \pm 2 \text{ }^\circ\text{C}$

Parameter	Symbol	Value			Unit	Note
		Min.	Typ.	Max.		
Lamp Input Voltage	V_L	734	815	897	V_{RMS}	$I_L = 6.0 \text{ mA}$
Lamp Current	I_L	5.5	6	6.5	mA_{RMS}	
Lamp Turn On Voltage	V_s	1320		3000	V_{RMS}	$T_a = 25 \text{ }^\circ\text{C}$
		1650		3000	V_{RMS}	$T_a = 0 \text{ }^\circ\text{C}$
Operating Frequency	F_L	40	50	60	KHz	
Lamp Life Time	L_{BL}	50000	60000	-	Hrs	
Power Consumption	P_L	-	37	-	W	Inverter Input

Note (1) Lamp current is measured by utilizing high frequency current meters as shown below:

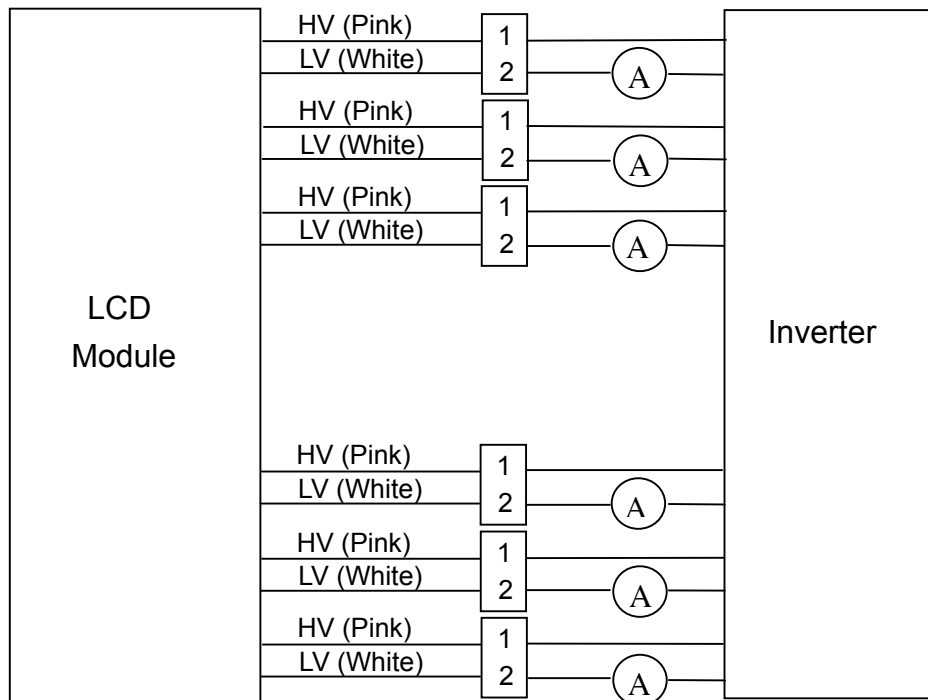

Note (2) The voltage shown above should be applied to the lamp for more than 1 second after startup. Otherwise the lamp may not be turned on.

Note (3) The lamp frequency may produce interference with horizontal synchronous frequency from the display, and this may cause line flow on the display. In order to avoid interference, the lamp frequency should be detached from the horizontal synchronous frequency and its harmonics as far as possible.

Note (4) $P_L = (\sum_{lamp1-lamp6} I_L \times V_L) / 0.8$, P_L is based on the inverter efficiency, which is 80%.

Note (5) The lifetime of a lamp is defined as the time in which it continues to operate under the condition $T_a = 25 \pm 2^\circ\text{C}$ and $I_L = (5.5) \sim (6.5)$ mA until one of the following events occurs:

(a) When the brightness becomes equal or less than 50% of its original value.

(b) When the effective discharge length becomes equal or less than 80% of its original value.

(Effective discharge length is defined as an area that has equal or more than 70% brightness compared to the brightness at the center point.)

Note (6) The waveform of the voltage output of inverter must be area-symmetric and the design of the inverter must have specifications for the modularized lamp. The performance of the Backlight, such as lifetime or brightness, is greatly influenced by the characteristics of the DC-AC inverter for the lamp. All the parameters of an inverter should be carefully designed to avoid producing too much current leakage from high voltage output of the inverter. When designing or ordering the inverter please make sure that a poor lighting caused by the mismatch of the Backlight and the inverter (miss-lighting, flicker, etc.) never occurs. If the above situation is confirmed, the module should be operated in the same manners when it is installed in your instrument.

4. BLOCK DIAGRAM

4.1 TFT LCD MODULE

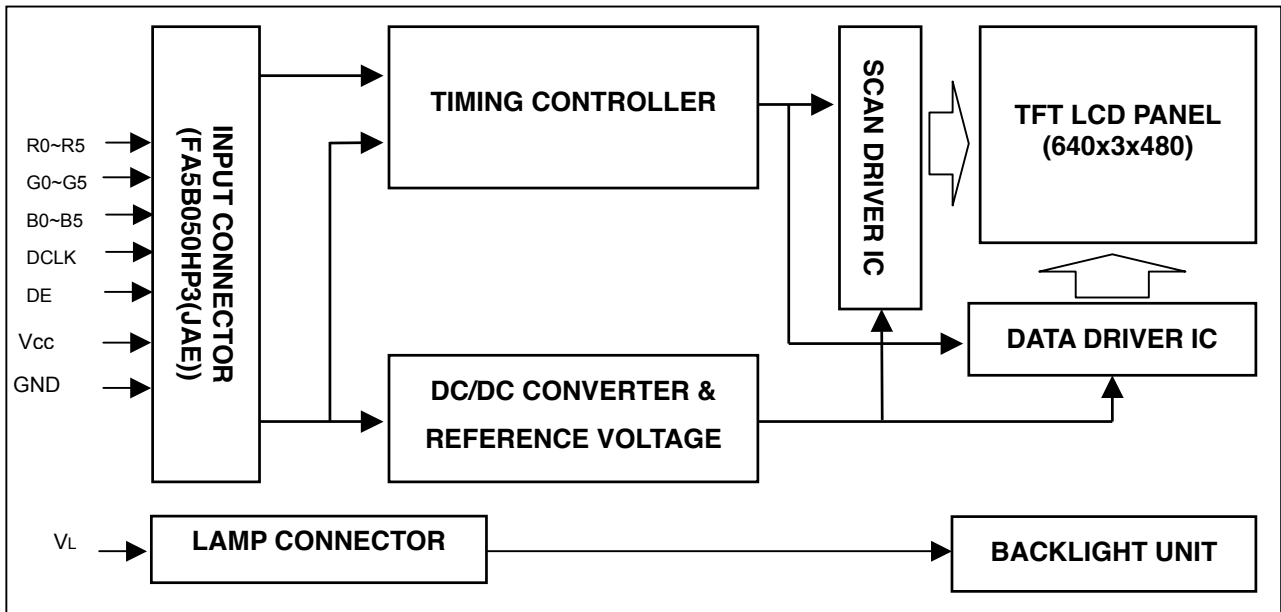

4.2 BACKLIGHT UNIT



5. INPUT TERMINAL PIN ASSIGNMENT

5.1 TFT LCD MODULE

Pin assignment

Pin	Name	Description	Pin	Name	Description
1	NC		26	NC	
2	NC		27	GND	Ground
3	NC		28	G5	Green Data (G5:MSB)
4	GND	Ground	29	G4	
5	GND	Ground	30	G3	
6	VCC	Power Input (+5.0V)	31	G2	
7	VCC		32	GND	
8	VCC		33	G1	Green Data
9	VCC		34	G0	
10	GND	Ground	35	NC	
11	NC		36	NC	
12	NC		37	GND	Ground
13	GND	Ground	38	B5	Blue Data (B5:MSB)
14	DE	Data Enable	39	B4	
15	GND	Ground	40	B3	
16	DCLK	Dot Clock	41	B2	
17	GND	Ground	42	GND	Ground
18	R5	Red Data (R5:MSB)	43	B1	Blue Data
19	R4		44	B0	
20	R3		45	NC	
21	R2		46	NC	
22	GND	Ground	47	GND	Ground
23	R1	Red Data	48	GND	Ground
24	R0		49	NC	
25	NC		50	NC	

Note (1) Connector Part No.: FA5B050HP3 (JAE) or compatible

5.2 BACKLIGHT UNIT

Pin	Symbol	Description	Color
1	HV1	High Voltage	Pink
2	LV	Ground	White

Note (1) Connector Part No.: BHSR-02VS-1 (JST) or equivalent

Note (2) Matching Connector Part No.: SM02-BHSS-1-TB (JST) or equivalent

5.3 COLOR DATA INPUT ASSIGNMENT

The brightness of each primary color (red, green and blue) is based on the 6-bit gray scale data input for the color. The higher the binary input, the brighter the color. The table below provides the assignment of color versus data input.

Color		Data Signal																	
		Red						Green						Blue					
		R5	R4	R3	R2	R1	R0	G5	G4	G3	G2	G1	G0	B5	B4	B3	B2	B1	B0
Basic Colors	Black	0	0	0	0	0	0	0	0	0	0	0	0	0	0	0	0	0	0
	Red	1	1	1	1	1	1	0	0	0	0	0	0	0	0	0	0	0	0
	Green	0	0	0	0	0	0	1	1	1	1	1	1	0	0	0	0	0	0
	Blue	0	0	0	0	0	0	0	0	0	0	0	0	1	1	1	1	1	1
	Cyan	0	0	0	0	0	0	1	1	1	1	1	1	1	1	1	1	1	1
	Magenta	1	1	1	1	1	1	0	0	0	0	0	0	1	1	1	1	1	1
	Yellow	1	1	1	1	1	1	1	1	1	1	1	1	0	0	0	0	0	0
	White	1	1	1	1	1	1	1	1	1	1	1	1	1	1	1	1	1	1
Gray Scale Of Red	Red(0) / Dark	0	0	0	0	0	0	0	0	0	0	0	0	0	0	0	0	0	0
	Red(1)	0	0	0	0	0	1	0	0	0	0	0	0	0	0	0	0	0	0
	Red(2)	0	0	0	0	1	0	0	0	0	0	0	0	0	0	0	0	0	0
	⋮	⋮	⋮	⋮	⋮	⋮	⋮	⋮	⋮	⋮	⋮	⋮	⋮	⋮	⋮	⋮	⋮	⋮	⋮
	⋮	⋮	⋮	⋮	⋮	⋮	⋮	⋮	⋮	⋮	⋮	⋮	⋮	⋮	⋮	⋮	⋮	⋮	⋮
	Red(62)	1	1	1	1	0	1	0	0	0	0	0	0	0	0	0	0	0	0
	Red(63)	1	1	1	1	1	0	0	0	0	0	0	0	0	0	0	0	0	0
	Red(64)	1	1	1	1	1	1	0	0	0	0	0	0	0	0	0	0	0	0
Gray Scale Of Green	Green(0) / Dark	0	0	0	0	0	0	0	0	0	0	0	0	0	0	0	0	0	0
	Green(1)	0	0	0	0	0	0	0	0	0	0	0	1	0	0	0	0	0	0
	Green(2)	0	0	0	0	0	0	0	0	0	0	1	0	0	0	0	0	0	0
	⋮	⋮	⋮	⋮	⋮	⋮	⋮	⋮	⋮	⋮	⋮	⋮	⋮	⋮	⋮	⋮	⋮	⋮	⋮
	⋮	⋮	⋮	⋮	⋮	⋮	⋮	⋮	⋮	⋮	⋮	⋮	⋮	⋮	⋮	⋮	⋮	⋮	⋮
	Green(62)	0	0	0	0	0	0	1	1	1	1	0	1	0	0	0	0	0	0
	Green(63)	0	0	0	0	0	0	1	1	1	1	1	0	0	0	0	0	0	0
	Green(64)	0	0	0	0	0	0	1	1	1	1	1	1	0	0	0	0	0	0
Gray Scale Of Blue	Blue(0) / Dark	0	0	0	0	0	0	0	0	0	0	0	0	0	0	0	0	0	0
	Blue(1)	0	0	0	0	0	0	0	0	0	0	0	0	0	0	0	0	0	1
	Blue(2)	0	0	0	0	0	⋮	0	0	0	0	0	⋮	0	0	0	0	1	0
	⋮	⋮	⋮	⋮	⋮	⋮	⋮	⋮	⋮	⋮	⋮	⋮	⋮	⋮	⋮	⋮	⋮	⋮	⋮
	⋮	⋮	⋮	⋮	⋮	0	⋮	⋮	⋮	⋮	⋮	⋮	0	⋮	⋮	⋮	⋮	⋮	⋮
	Blue(62)	0	0	0	0	0	0	0	0	0	0	0	0	1	1	1	1	0	1
	Blue(63)	0	0	0	0	0	0	0	0	0	0	0	0	1	1	1	1	1	0
	Blue(64)	0	0	0	0	0	0	0	0	0	0	0	0	1	1	1	1	1	1

Note (1) 0: Low Level Voltage, 1: High Level Voltage

6. INTERFACE TIMING

6.1 INPUT SIGNAL TIMING SPECIFICATIONS

The input signal timing specifications are shown as the following table and timing diagram.

Signal	Item	Symbol	Min.	Typ.	Max.	Unit	Note
Clock	Frequency	1/Tc	20	25	30	MHz	-
	Input Cycle to Cycle jitter	Trcl	--	--	300	ps	-
Vertical Active Display Term	Frame Rate	Fr	47	60	63	Hz	-
	Total	Tv	500	525	550	Th	Tv=Tvd+Tvb
	Display	Tvd	480	480	480	Th	-
	Blank	Tvb	20	45	70	Th	-
Horizontal Active Display Term	Total	Th	750	800	850	Tc	Th=Thd+Thb
	Display	Thd	640	640	640	Tc	-
	Blank	Thb	110	160	210	Tc	-
Input data Term	Setup time	Ts	15	--	--	ns	
	Hold time	TH	10	--	--	ns	
DE Term	Setup time	T _{SDE}	15	--	--	ns	
	Hold time	T _{HDE}	10	--	--	ns	

Note: Since this module is operated in DE only mode, Hsync and Vsync input signals should be set to low logic level or ground. Otherwise, this module would operate abnormally.

INPUT SIGNAL TIMING DIAGRAM

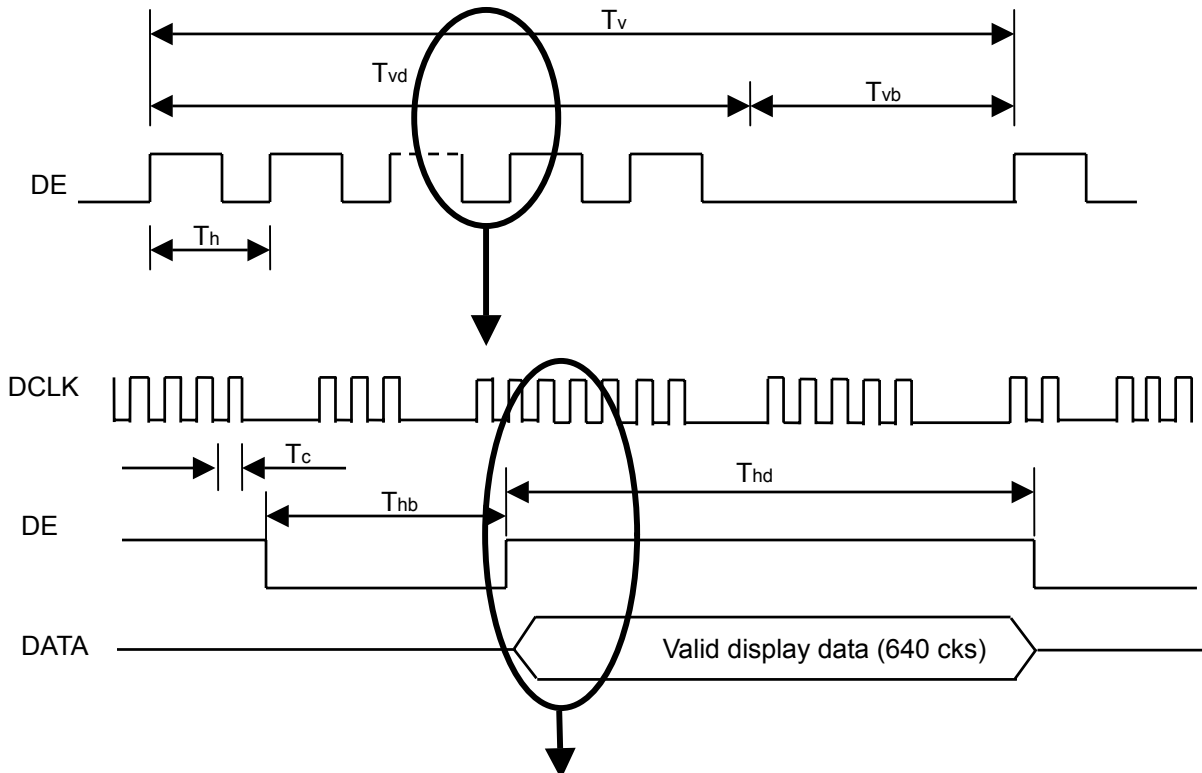

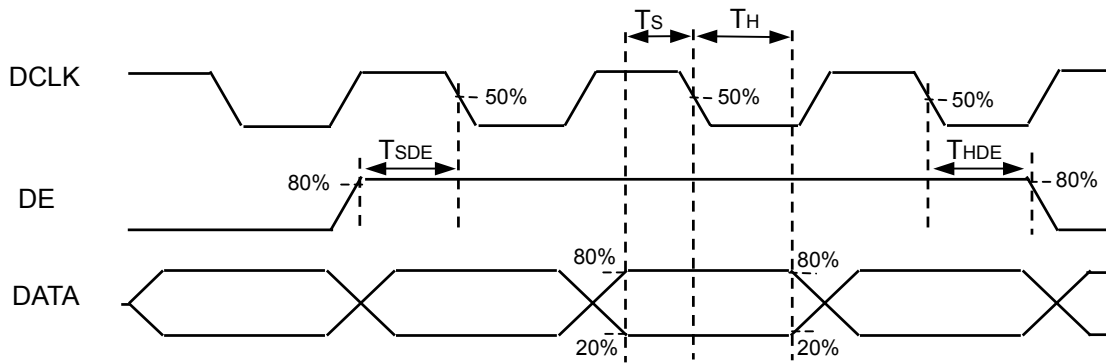

6.2 POWER ON/OFF SEQUENCE

To prevent a latch-up or DC operation of LCD module, the power on/off sequence should be as the diagram below.

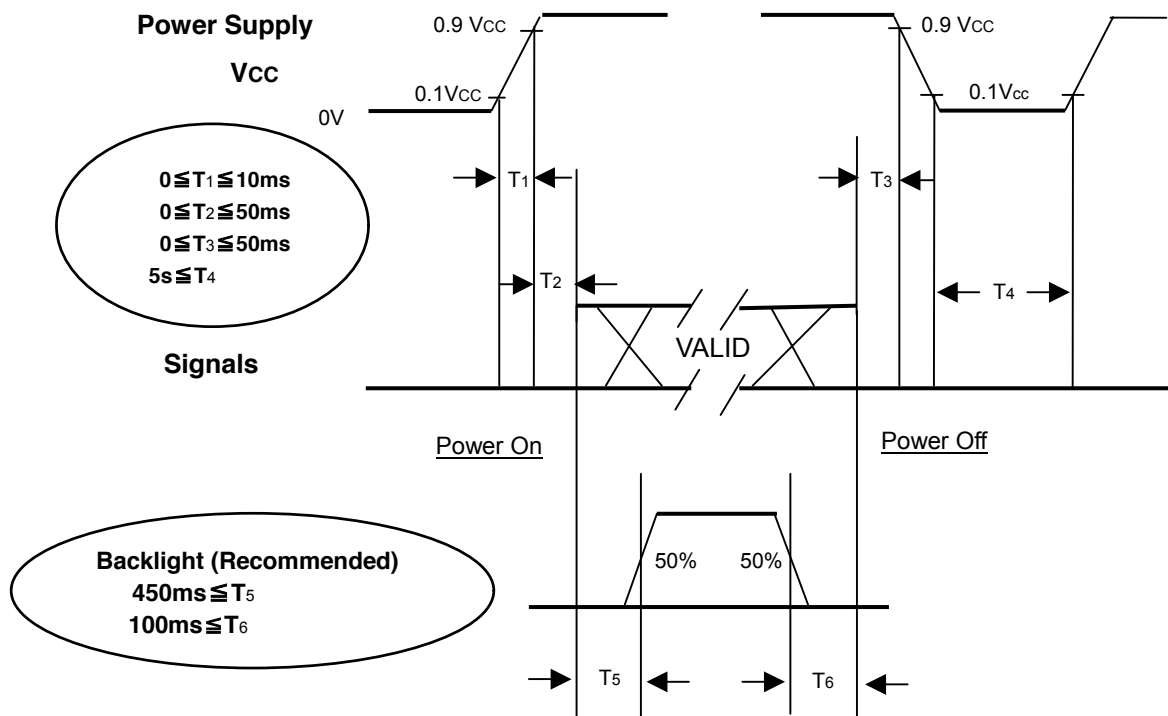

Note.

- (1) The supply voltage of the external system for the module input should be the same as the definition of Vcc.
- (2) Apply the lamp voltage within the LCD operation range. When the backlight turns on before the LCD operation or the LCD turns off before the backlight turns off, the display may momentarily become abnormal screen.
- (3) In case of VCC = off level, please keep the level of input signals on the low or keep a high impedance.
- (4) T4 should be measured after the module has been fully discharged between power off and on period.
- (5) Interface signal shall not be kept at high impedance when the power is on.

7. OPTICAL CHARACTERISTICS

7.1 TEST CONDITIONS

Item	Symbol	Value	Unit
Ambient Temperature	Ta	25±2	°C
Ambient Humidity	Ha	50±10	%RH
Supply Voltage	V _{CC}	5.0	V
Input Signal	According to typical value in "3. ELECTRICAL CHARACTERISTICS"		
Inverter Current	I _L	6	mA
Inverter Driving Frequency	F _L	55	KHz
Inverter	SUMIDA IV76240/T --		

7.2 OPTICAL SPECIFICATIONS

The relative measurement methods of optical characteristics are shown in 7.2. The following items should be measured under the test conditions described in 7.1 and stable environment shown in Note (6).

Item	Symbol	Condition	Min.	Typ.	Max.	Unit	Note	
Contrast Ratio	CR	$\theta_x=0^\circ, \theta_y=0^\circ$ Viewing Normal Angle		(500)	-	-	Note(2)	
Response Time	T _R		-	(3)			ms	Note(3)
	T _F		-	(5)			ms	
Center Luminance of White	L _C			(500)	-		cd/m ²	Note(4)
White Variation	δW			-	-	1.6	-	Note(7)
Cross Talk	CT			-	-	4	%	Note(5)
Color Chromaticity	Red		R _x		(0.649)		-	Note(6)
			R _y		(0.330)		-	
	Green		G _x		(0.277)		-	
			G _y		(0.591)		-	
	Blue	B _x		(0.143)		-		
		B _y		(0.066)		-		
	White	W _x		0.285		-	9, 300K	
W _y			0.293		-			
Color Gamut			75	-		%		
Viewing Angle	Horizontal	θ_{x+}		(80)	-	Deg.	Note(1)	
		θ_{x-}		(80)	-			
	Vertical	θ_{y+}	CR≥10		(70)			-
		θ_{y-}			(70)			-

Note (1) Definition of Viewing Angle (θ_x, θ_y):

Viewing angles are measured by EZ-Contrast 160R (Eldim)

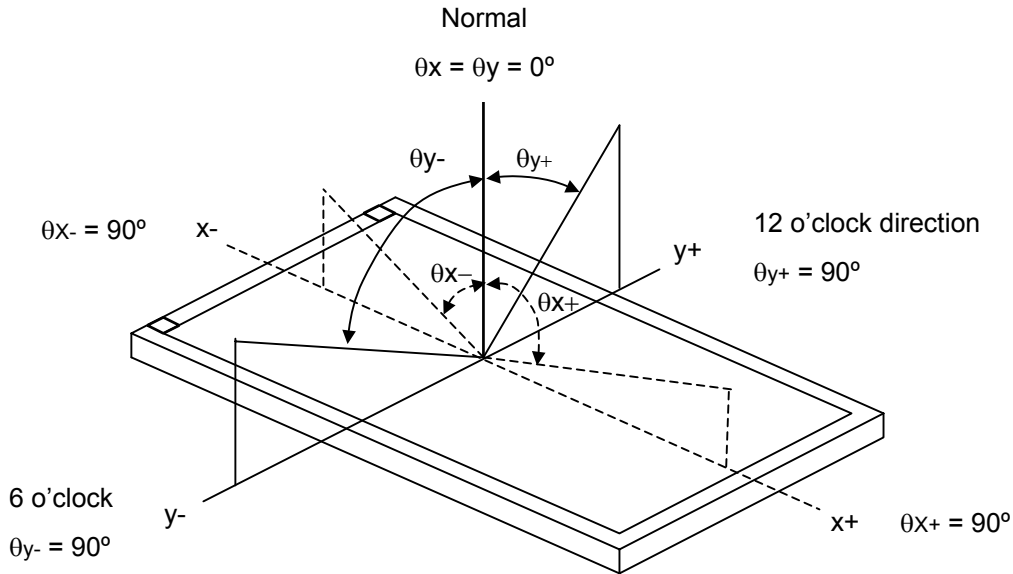

Note (2) Definition of Contrast Ratio (CR):

The contrast ratio can be calculated by the following expression.

$$\text{Contrast Ratio (CR)} = L_{63} / L_0$$

L63: Luminance of gray level 63

L 0: Luminance of gray level 0

$$\text{CR} = \text{CR} (5)$$

CR (X) is corresponding to the Contrast Ratio of the point X at the figure in Note (7).

Note (3) Definition of Response Time (T_R, T_F):

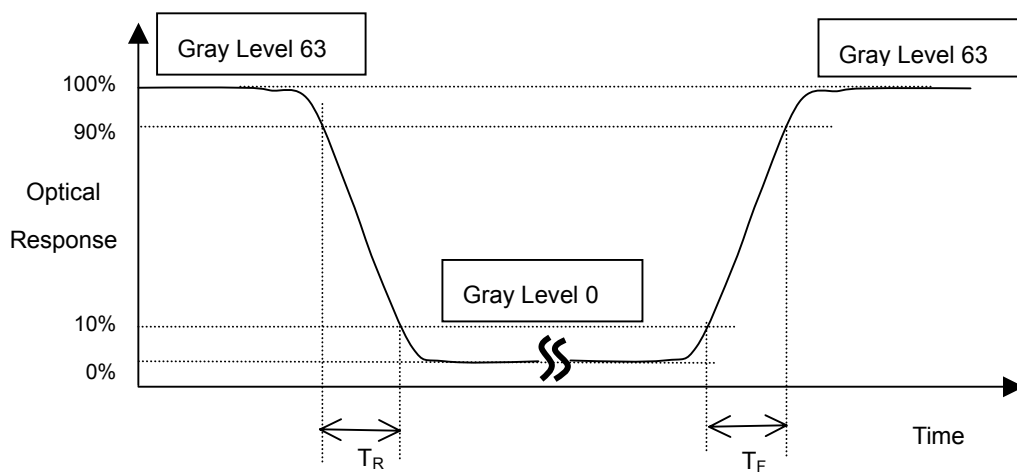

Note (4) Definition of Luminance of White (L_C , L_{AVE}):

Measure the luminance of gray level 63 at center point and 5 points

$$L_C = L(5)$$

$$L_{AVE} = [L(1) + L(2) + L(3) + L(4) + L(5)] / 5$$

$L(x)$ is corresponding to the luminance of the point X at the figure in Note (7).

Note (5) Definition of Cross Talk (CT):

$$CT = |Y_B - Y_A| / Y_A \times 100 (\%)$$

Where:

Y_A = Luminance of measured location without gray level 0 pattern (cd/m^2)

Y_B = Luminance of measured location with gray level 0 pattern (cd/m^2)

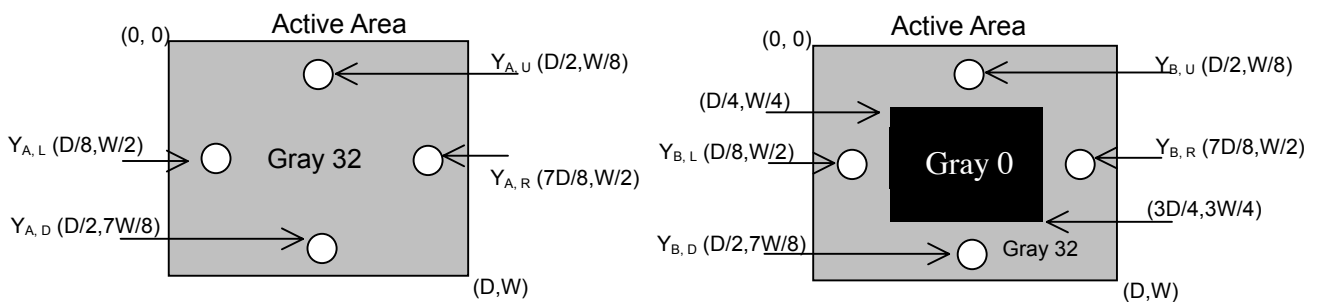

Note (6) Measurement Setup:

The LCD module should be stabilized at given temperature for 30 minutes to avoid abrupt temperature change during measuring. In order to stabilize the luminance, the measurement should be executed after lighting Backlight for 30 minutes in a windless room.

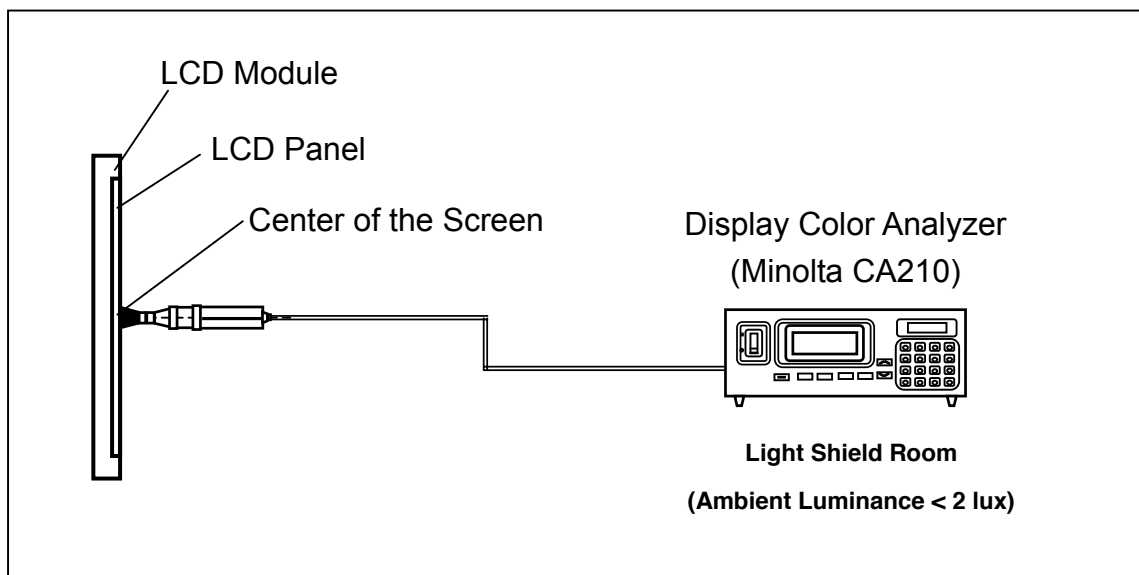

Note (7) Definition of White Variation (δW):

Measure the luminance of gray level 63 at 5 points

$$\delta W = \text{Maximum } [L(1), L(2), L(3), L(4), L(5)] / \text{Minimum } [L(1), L(2), L(3), L(4), L(5)]$$

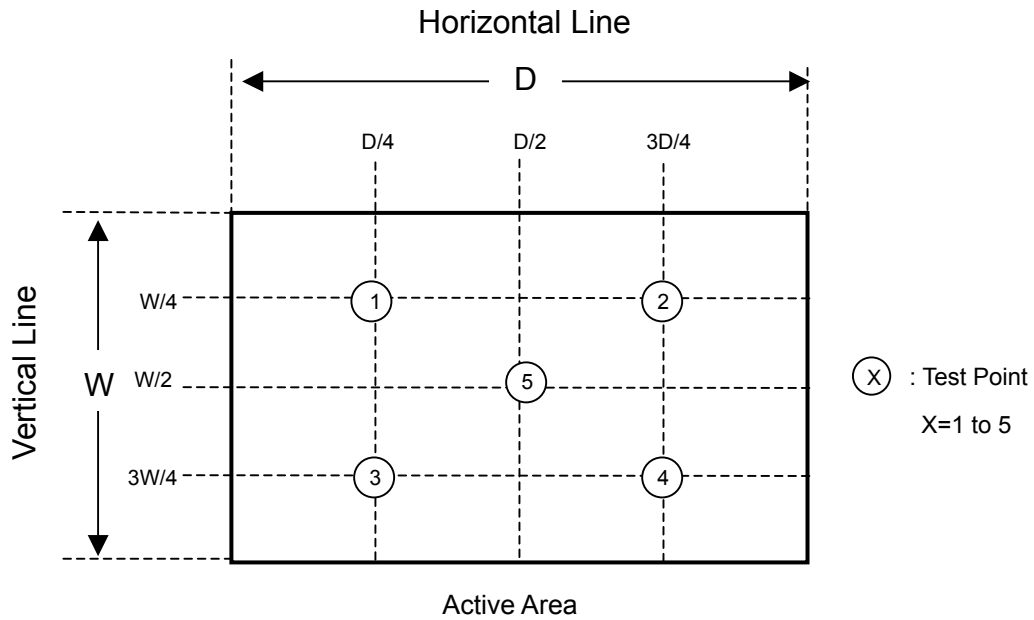

8. PACKAGING

8.1 PACKING SPECIFICATIONS

- (1) 5 LCD TV modules / 1 Box
- (2) Box dimensions : 573(L) X 323 (W) X 470 (H)
- (3) Weight : approximately 18.5Kg (5 modules per box)

8.2 PACKING METHOD

Figures 8-1 and 8-2 are the packing method

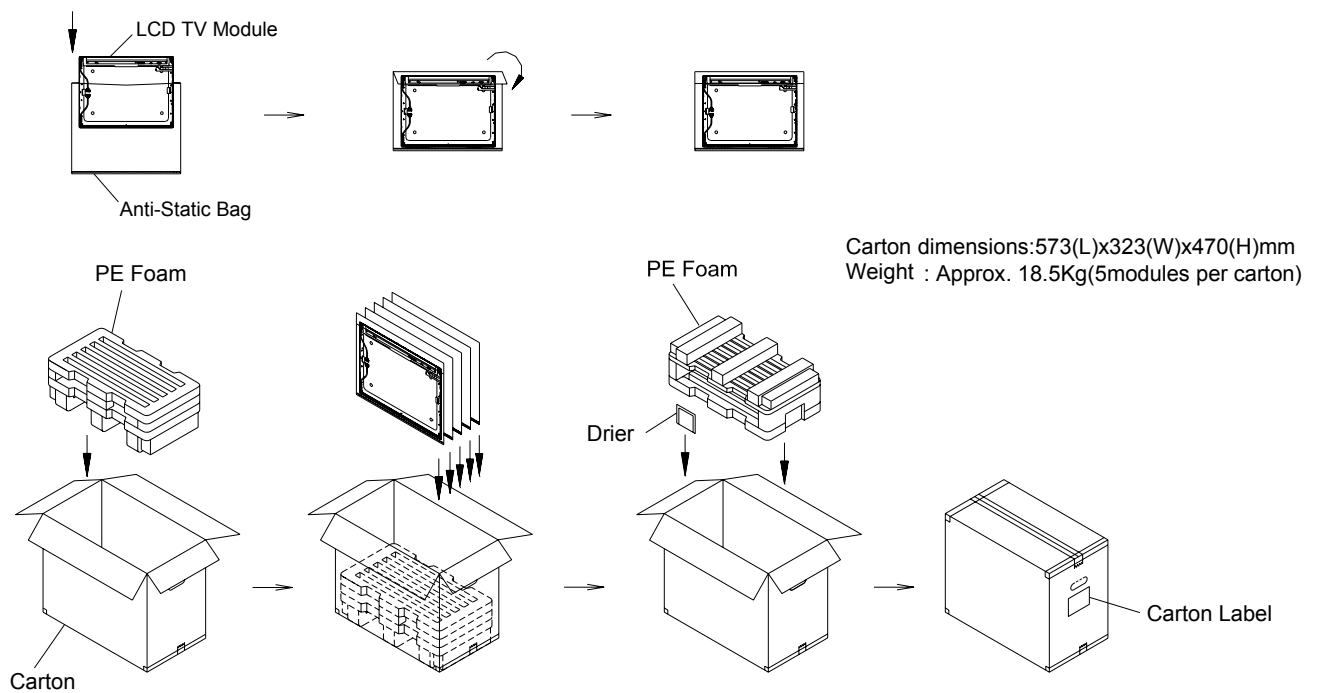

Figure.8-1 packing method

Corner Protector:L1400*50mm*50mm
Pallet:L1180*W1000*H135mm
Corrugated Fiberboard:L1180*W1000mm
Pallet Stack:L1180*W1000*H1555mm
Gross:355kg

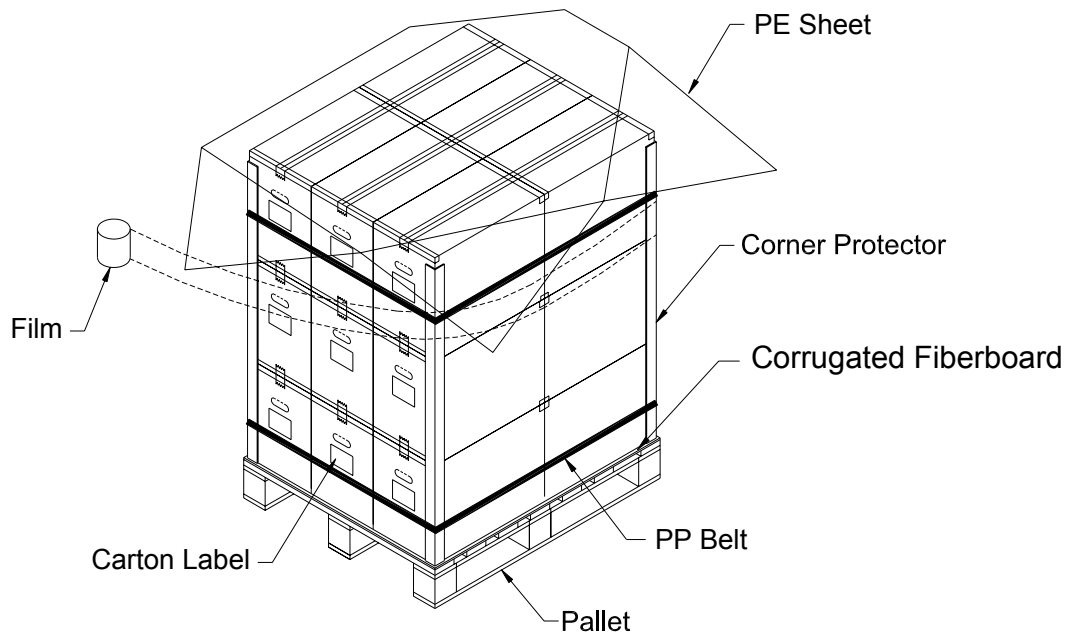
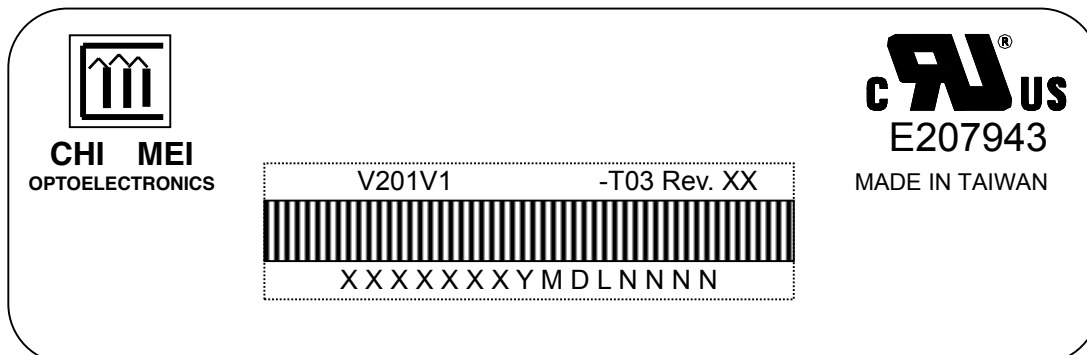

Figure. 8-2 Packing method

9. DEFINITION OF LABELS

9.1 CMO MODULE LABEL

The barcode nameplate is pasted on each module as illustration, and its definitions are as following explanation.



- (a) Model Name: V201V1-T03
- (b) Revision: Rev. XX, for example: A0, A1... B1, B2... or C1, C2...etc.
- (c) Serial ID: XXXXXXXXYMDLNNNN

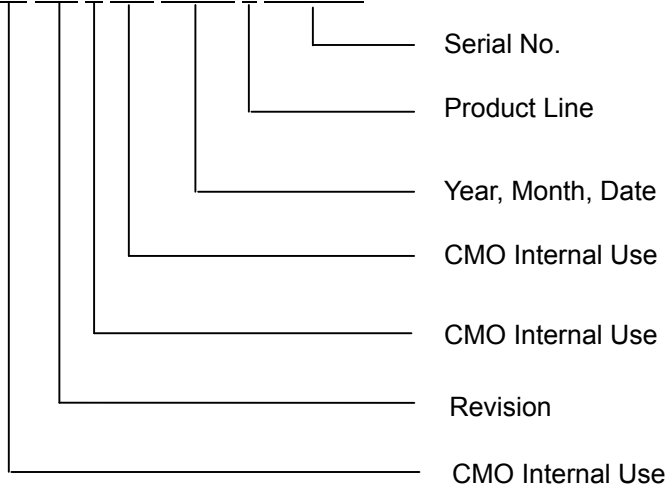

Serial ID includes the information as below:

- (a) Manufactured Date: Year: 1~9, for 2000~2009
Month: 1~9, A~C, for Jan. ~ Dec.
Day: 1~9, A~Y, for 1st to 31st, exclude I ,O, and U.
- (b) Revision Code: Cover all the change
- (c) Serial No.: Manufacturing sequence of product
- (d) Product Line: 1 -> Line1, 2 -> Line 2, ...etc.

10. PRECAUTIONS

10.1 ASSEMBLY AND HANDLING PRECAUTIONS

- (1) Do not apply rough force such as bending or twisting to the module during assembly.
- (2) It is recommended to assemble or to install a module into the user's system in clean working areas.
The dust and oil may cause electrical short or worsen the polarizer.
- (3) Do not apply pressure or impulse to the module to prevent the damage of LCD panel and Backlight.
- (4) Always follow the correct power-on sequence when the LCD module is turned on. This can prevent the damage and latch-up of the CMOS LSI chips.
- (5) Do not plug in or pull out the I/F connector while the module is in operation.
- (6) Do not disassemble the module.
- (7) Use a soft dry cloth without chemicals for cleaning, because the surface of polarizer is very soft and easily scratched.
- (8) Moisture can easily penetrate into LCD module and may cause the damage during operation.
- (9) High temperature or humidity may deteriorate the performance of LCD module. Please store LCD modules in the specified storage conditions.
- (10) When ambient temperature is lower than 10°C, the display quality might be reduced. For example, the response time will become slow, and the starting voltage of CCFL will be higher than that of room temperature.

10.2 SAFETY PRECAUTIONS

- (1) The startup voltage of a Backlight is approximately 1000 Volts. It may cause an electrical shock while assembling with the inverter. Do not disassemble the module or insert anything into the Backlight unit.
- (2) If the liquid crystal material leaks from the panel, it should be kept away from the eyes or mouth. In case of contact with hands, skin or clothes, it has to be washed away thoroughly with soap.
- (3) After the module's end of life, it is not harmful in case of normal operation and storage.

11. MECHANICAL CHARACTERISTICS

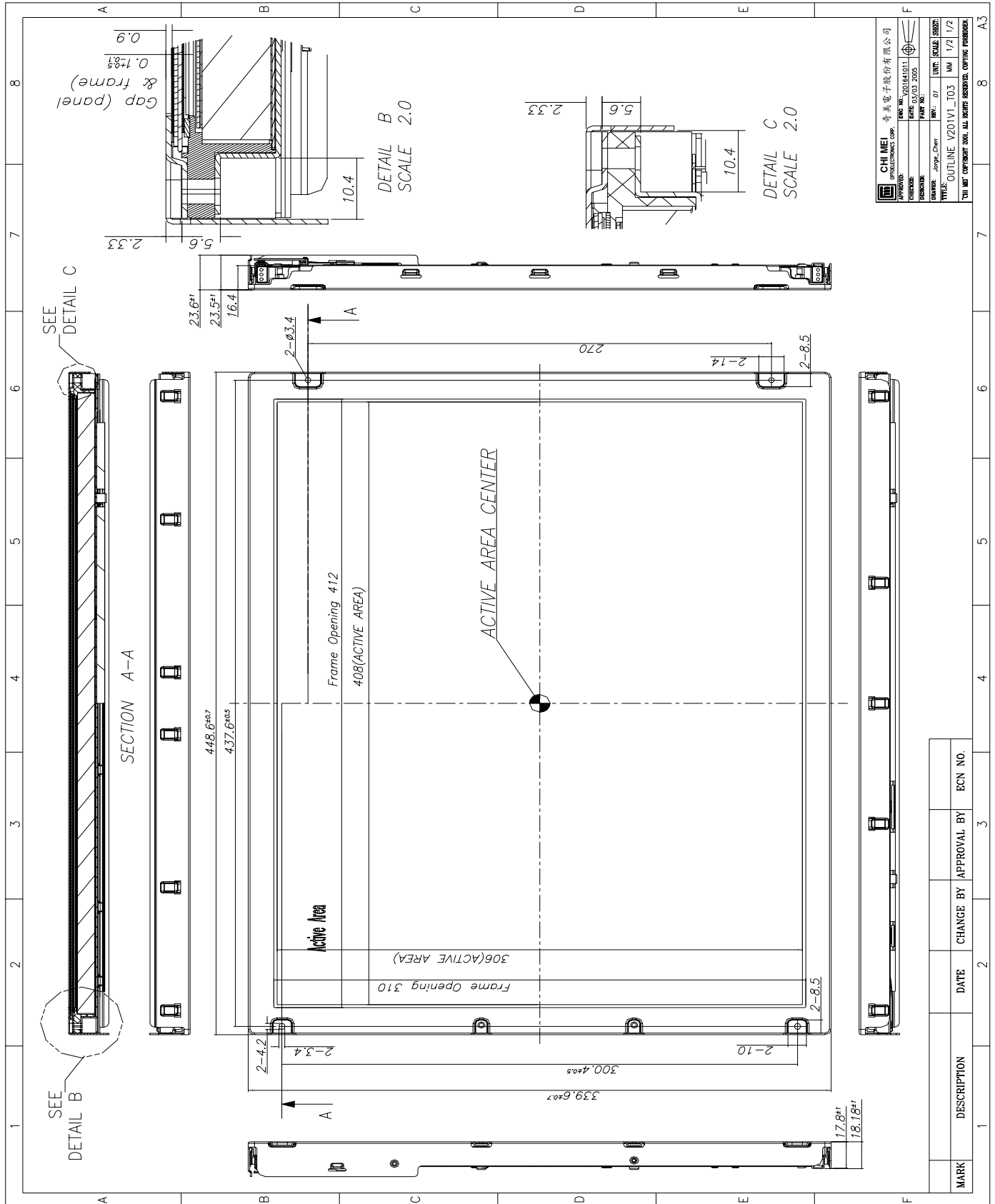

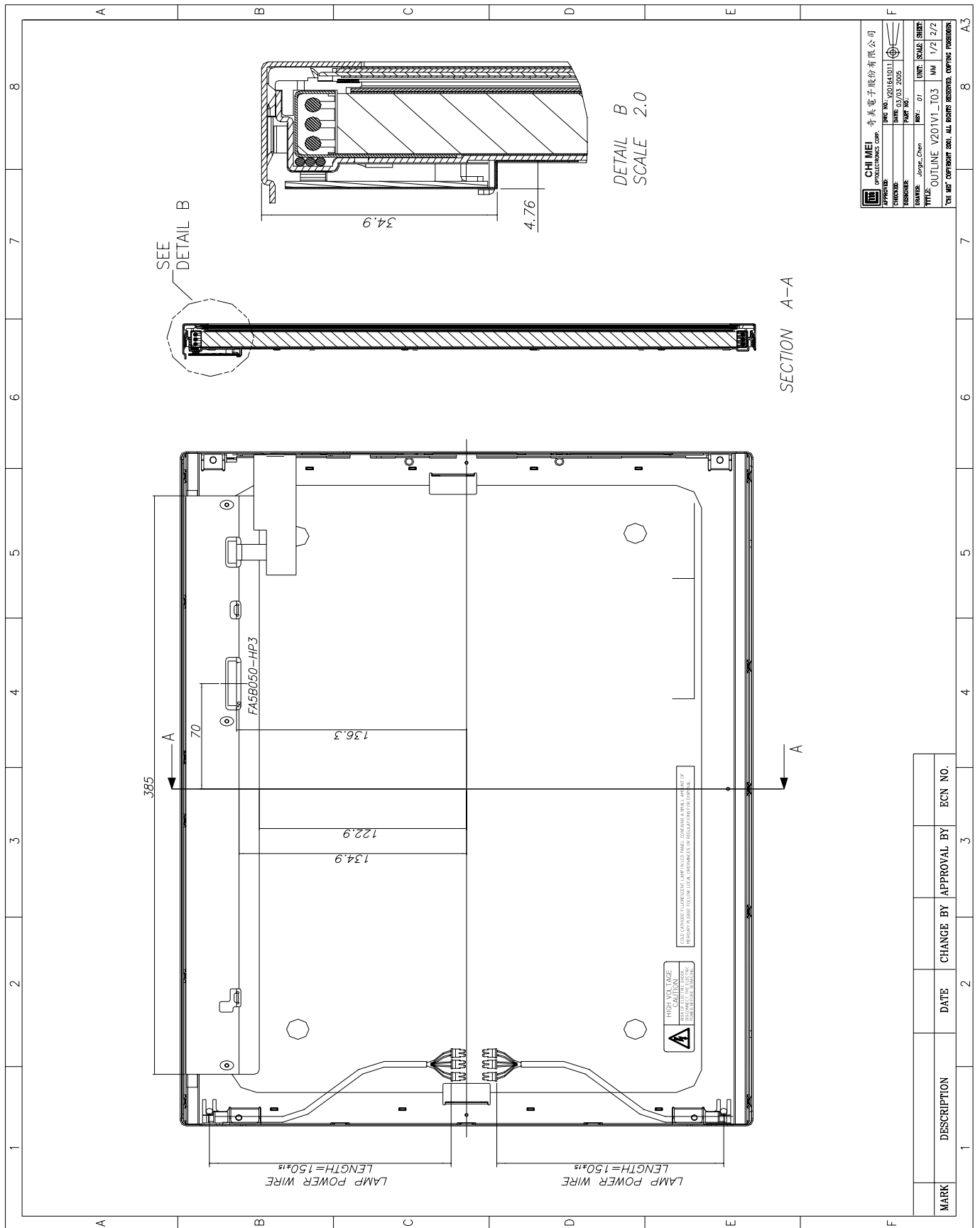

CHI MEI OPTOELECTRONICS CORP.		奇美電子股份有限公司	
APPROVED:	DATE: V201V1-T03	DATE: 03/03/2005	SCALE: 1/2 2/2
CHECKED:	DATE: 03/03/2005	UNIT: MM	SHR: 1/2 2/2
DESIGNED:	NAME: Juyue Chen	REV: 01	UNIT: MM
TITLE: OUTLINE V201V1-T03			
THE MEI COMPANY SOI. ALL RIGHTS RESERVED. OPENING PROHIBITED.			

MARK	DESCRIPTION	DATE	CHANGE BY	APPROVAL BY	ECN NO.