



# Chunghwa Picture Tubes, Ltd.

## Technical Specification

To : **BENQ**  
Date : 2006.02.27

*CPT TFT-LCD*

**CLAA320WB02**

**ACCEPTED BY :**

**TENTATIVE**

APPROVED BY	CHECKED BY	PREPARED BY
		<b>TFT-LCD Product Planning Management General Division</b>

**Product Planning Management General Division  
CHUNGHWA PICTURE TUBES, LTD.**

<b>Doc.No:</b>	CLAA320WB02-BENQ-Ver2.0-2006/02/27	<b>Issue Date:</b>	2006/02/27
----------------	------------------------------------	--------------------	------------

T- 3650002- 000- A NEW



**CONTENTS**

<b>No</b>	<b>Item</b>	<b>Page</b>
1	OVERVIEW	3
2	ABSOLUTE MAXIMUM RATINGS	4
3	TFT-LCD MODULE	5
4	INTERFACE PIN CONNECTION	9
5	INTERFACE TIMING	12
6	BLOCK DIAGRAM	17
7	MECHANICAL SPECIFICATION	18
8	OPTICAL CHARACTERISTICS	20
9	RELIABILITY	23
10	PACKAGING	24
11	HANDLING PRECAUTIONS FOR TFT-LCD MODULE	26

## 1. OVERVIEW

CLAA320WB02 is 32" color (80.04cm) TFT-LCD (Thin Film Transistor Liquid Crystal Display) module composed of LCD panel, LVDS driver ICs, control circuit, backlight, and inverter. By applying 8 bit digital data, 1366\*768, 16.7 million-color images are displayed on the 32" diagonal screen. General specification are summarized in the following table:

### 1.1 GENERAL INFORMATION

ITEM	SPECIFICATION	UNIT
Display Area	697.68 (H) × 392.25 (V) (31.51 inch diagonal)	mm
Number of Pixels	1366 (H) × 768 (V)	16:9
Pixel Pitch	0.51075 (H) × 0.51075 (V)	mm
Color Pixel Arrangement	RGB Vertical Strip	
Display Mode	Normally Black	
Number of Colors	16.7M (8bit)	color
Surface Treatment	Hard coating: 3H	
Total Module Power	115 (typ)	W

### 1.2 MECHANICAL INFORMATION

ITEM		MIN	TYP.	MAX.	UNIT
Module outline dimension	Horizontal (H)	759.0	760.0	761.0	mm
	Vertical (V)	449.0	450.0	451.0	mm
	Depth (D) with inverter	44.0	45.0	46.0	mm
Module Weight		--	--	8000	g

## 2. ABSOLUTE MAXIMUM RATINGS

The following are maximum values which, if exceeded, may cause faulty operation or damage to the module.

ITEM	SYMBOL	MIN.	MAX.	UNIT	REMARK
Power Supply Voltage For LCD	VCC	- 0.3	15.0	V	
Input voltage of inverter	VBL	- 0.3	27.0	V	
Inverter dimming	VDIM	- 0.3	3.5	Vdc	
Backlight on control voltage	V <sub>B</sub> LON	- 0.3	5.5	Vdc	
ESD for Connector	VESD	-250	250	V	
ESD for Module	VESD	-15	15	KV	
Operation Ambient Temperature	T <sub>op</sub>	0	50	°C	*1) *2) *3) *4)
Storage Temperature	T <sub>stg</sub>	-20	60	°C	*1) *2) *3) *4)

[Note]

- \*1) The relative temperature and humidity range are as below sketch.(90%RHMax / Ta ≤ 40°C)
- \*2) The maximum wet bulb temperature ≤ 39°C (Ta > 40°C) and without dewing.
- \*3) If you use the product in a environment which over the definition of temperature and humidity too long, and it will effect the result of visible inspection.
- \*4) While the product operates in normal temperature range, the center surface of panel should be under 60°C.
- \*5) Input voltage of the connector side in Inverter.

Humidity:

Humidity ≤ 85%RH without condensation.

Relative Humidity ≤ 90% (Ta ≤ 40°C)

Wet Bulb Temperature ≤ 39°C (Ta ≥ 40°C)

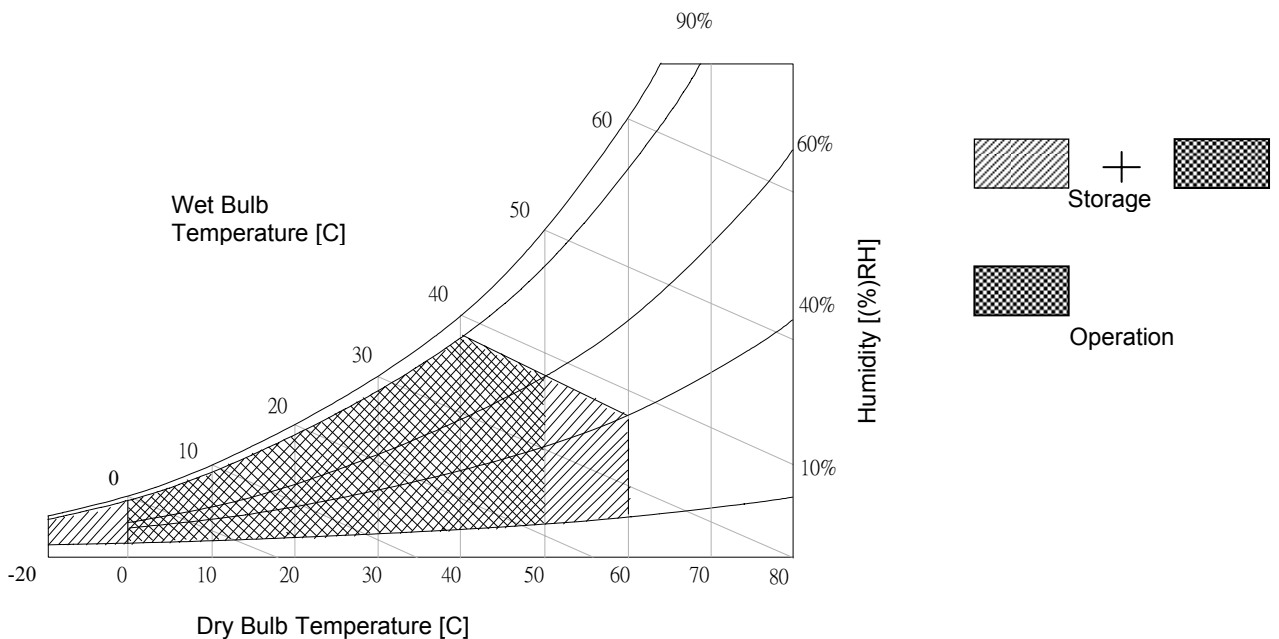

### 3. ELECTRICAL CHARACTERISTICS

#### 3.1 TFT-LCD MODULE

Ta=25°C

ITEM	SYMBOL	MIN	TYP	MAX	UNIT	REMARK
LCD Power Supply Voltage	VCC	11.4	12.0	12.6	V	*1)
Ripple Voltage	Vrpd	--	--	100	mVp-p	VIN=+12.0V
Rush Current	Irush	--	--	4	A	*2)
LCD Power Supply Current	White	--	350	400	mA	*3)
	Black	--	300	400		
	RGB stripe	--	320	400		
LCD Power Consumption	Pc	--	5.0	8.0	W	
High Input Voltage of LVDS	V <sub>IN+</sub>	--	--	100	mV	*4) *5)
Low Input Voltage of LVDS	V <sub>IN-</sub>	100	--	--	mV	
Input Common Voltage of LVDS	VCM	--	1.25	-	V	
Input Terminal Resist of LVDS	R <sub>T</sub>	--	100	--	ohm	

[Note]

\*1) The module should be always operated within above ranges.

\*2) Measure conditions:

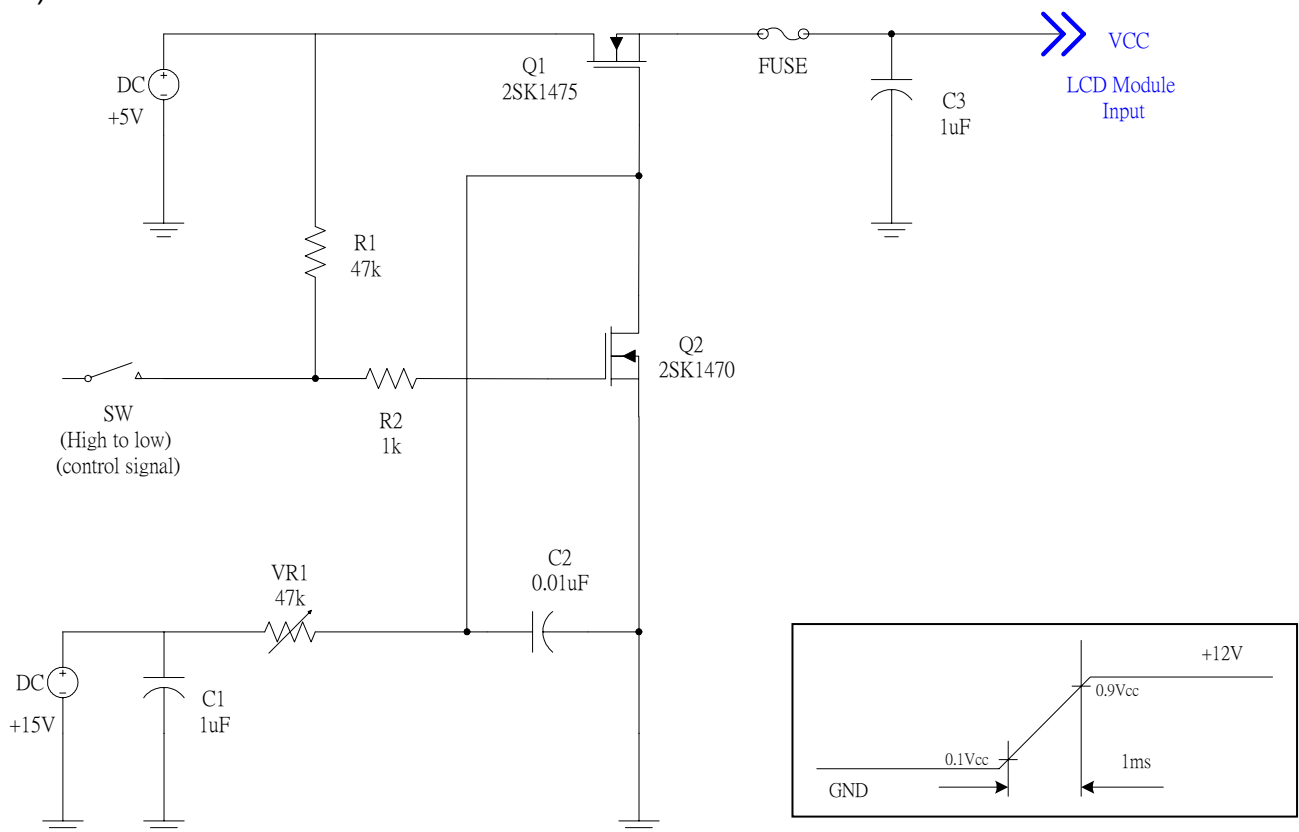

Vcc rising time is 1 ms

\*3) The specified power supply current is under condition at  $V_{cc}=12V$ ,  $T_a=25\pm 2^\circ C$ ,  $f_v=60Hz$ , whereas a power dissipation check pattern below is displayed.

a. White pattern



b. Black pattern

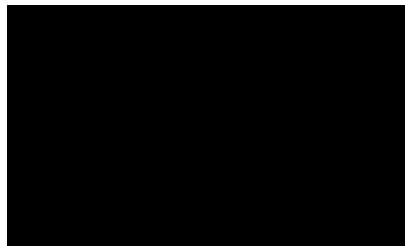

c. RGB Stripe pattern

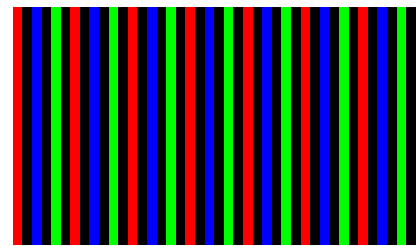

\*4) Power and Signal Sequence:

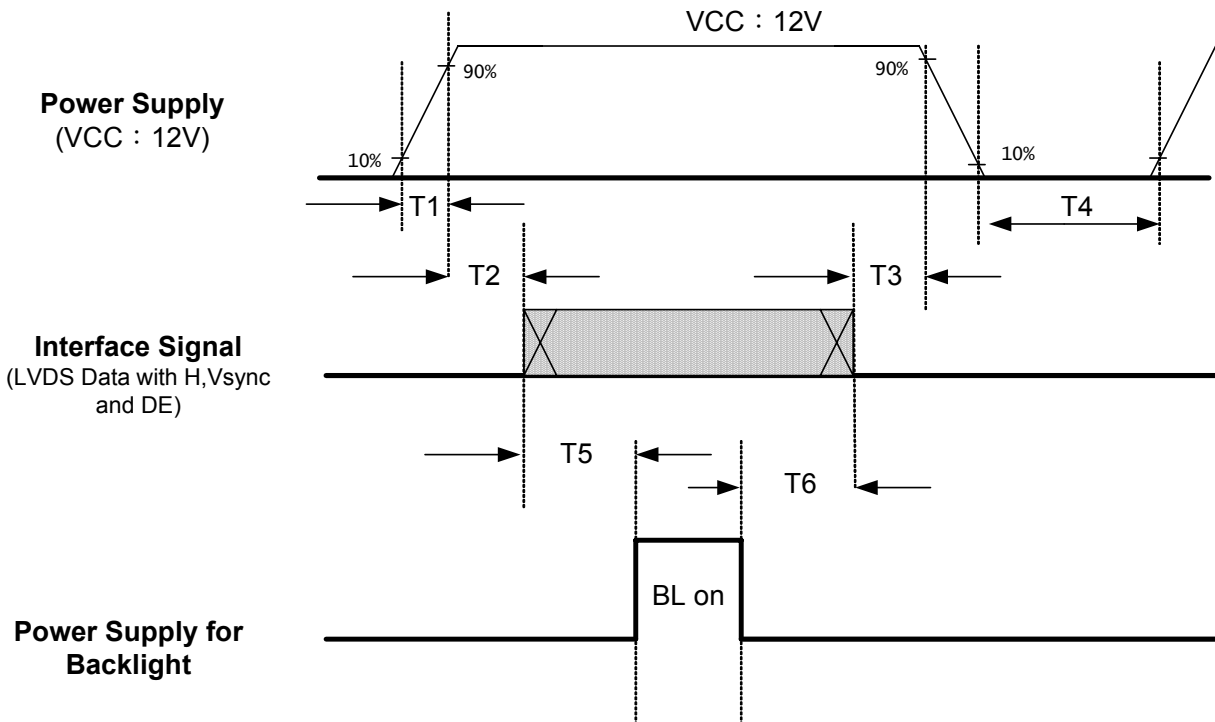

Power Sequence Table

Parameter	Value			Unit
	Min	Typ	Max	
T1	1	---	30	ms
T2	1	---	50	ms
T3	0	---	50	ms
T4	2000	---		ms
T5	110	---		ms
T6	100	---		ms

Notes:

- Please avoid floating state of interface signal at invalid period.
- When the interface signal is invalid, be sure to pull down the power supply for LCD to 0V.
- Lamp power must be turn off after power supply for LCD interface signal valid.

VCC-dip State:

- 1) When  $9V \leq VCC < 11.4V$ ,  $t_d \leq 10$  ms.
- 2)  $VCC > 11.4V$ , VCC-dip condition should also follow the VCC-turn-off condition.

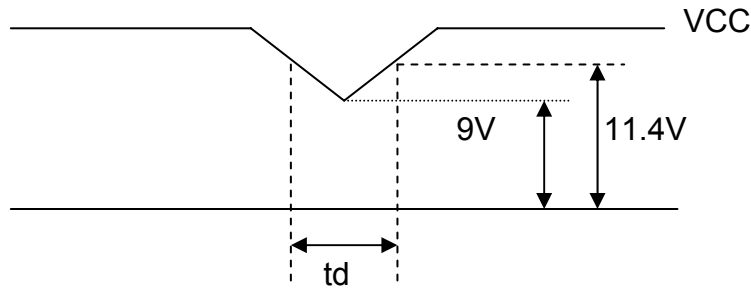

\*5) LVDS Signal Definition:

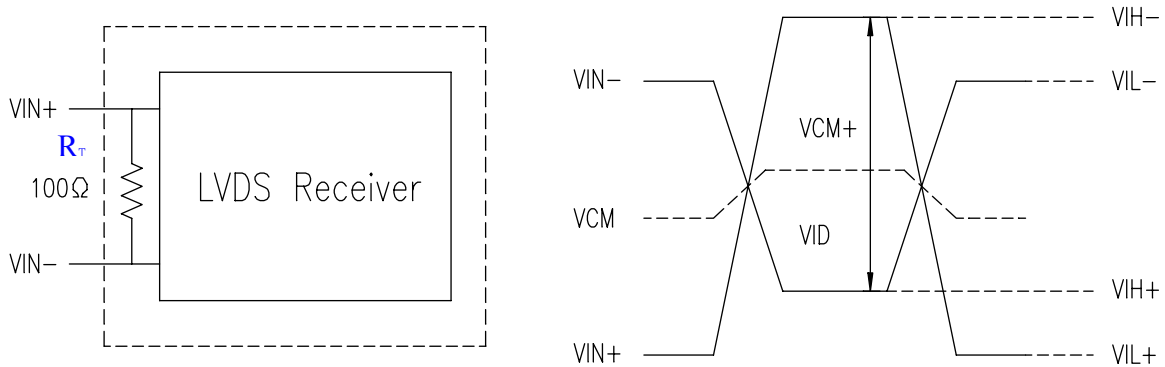

$$VID = VIN_+ - VIN_-$$

$$\Delta VCM = |VCM_+ - VCM_-|$$

$$\Delta VID = |VID_+ - VID_-|$$

$$VID_+ = |VIH_+ - VIH_-|$$

$$VID_- = |VIL_+ - VIL_-|$$

$$VCM = (VIN_+ + VIN_-) / 2$$

$$VCM_+ = (VIH_+ + VIH_-) / 2$$

$$VCM_- = (VIL_+ + VIL_-) / 2$$

VIN+: Positive Polarity differential DATA & CLK input

VIN-: Negative Polarity differential DATA & CLK input



## 3.2 BACKLIGHT

Ta = 25°C, VCC=12V, Turn on for 30 minutes

ITEM	SYMBOL	MIN	TYP	MAX	UNIT	REMARK	
Lamp Life Time	LT	50000	--	--	hr	*1)	
Input Voltage of Inverter	VBL	21.6	24	26.4	V	*2)	
Input Current of Inverter	IIN	--	(4.5)	(5.5)	A	*3)	
Internal Dimming Control Voltage	PDIM	0	--	3.3	V	*4)	
External PWM Frequency	FDIM	100	--	350	Hz		
External PWM Dimming Control Voltage	PDIM	2.0	--	3.3	V	High *5)	
	PDIM	0	--	0.8	V	Low *5)	
PWM Select Voltage	Vsel	2.0	--	3.3	V	High *5)	
	Vsel	0	--	0.8	V	Low*5)	
Inverter Duty Ratio	D	20	--	100	%		
Backlight on /off Control Voltage	ON	VBLON	2.4	--	5	V	
	OFF		0	--	0.8		
Power Consumption (Backlight )	BLW	--	(108)	(132)	W	*3)	

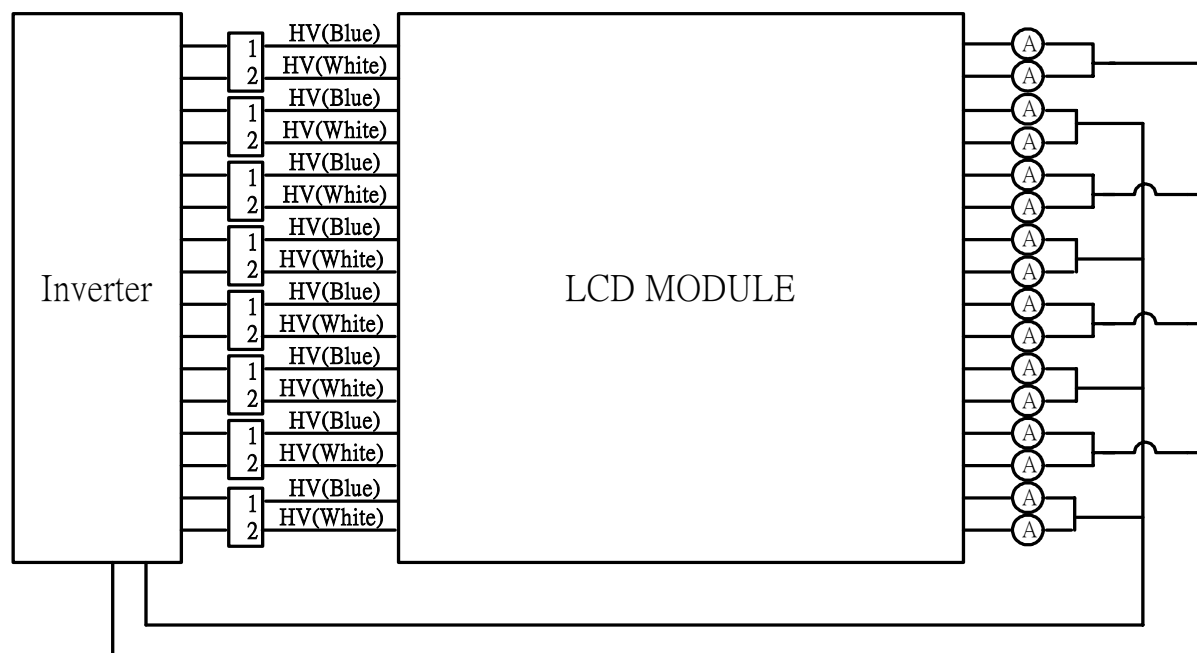

## [Note]

\*1) Definition of the lamp life time:

When lamp luminance reduce to 50% or lower than its initial value.

\*2) Ripple voltage that occur at the instant of power-on can't exceed 30V.

\*3) Max value of the power consumption and input current is measured at initial turn on of the backlight.

\*4) Internal PWM control with Analog input voltage.

Brightness is the darkest when VDIM = 0V;

Brightness is the brightest when VDIM = 3.3V.

\*5) Duty Signal Input with 3.3V TTL specification.

## 4. INTERFACE PIN CONNECTION

### 4.1 Connector Part No.: 20389-030E(I-PEX), FI-X30SSL-HF(JAE), or compatible

Pin NO	Symbol	Description	Note
1	VCC	+12V, DC, Regulated	
2	VCC	+12V, DC, Regulated	
3	VCC	+12V, DC, Regulated	
4	VCC	+12V, DC, Regulated	
5	GND	Ground	
6	OD SEL	OverDrive Look-up Table Selection	(1)
7	GND	DE Mode	
8	GND	Ground	
9	DMS	LVDS Option	(2)
10	NC	No Connection	(3)
11	GND	Ground	
12	RxIN0-	Data-	
13	RxIN0+	Data+	
14	GND	Ground	
15	RxIN1-	Data-	
16	RxIN1+	Data+	
17	GND	Ground	
18	RxIN2-	Data-	
19	RxIN2+	Data+	
20	GND	Ground	
21	RxCLKIN-	Clock-	
22	RxCLKIN+	Clock+	
23	GND	Ground	
24	RxIN3-	Data-	
25	RxIN3+	Data+	
26	GND	Ground	
27	NC	No Connection	(3)
28	NC	No Connection	(3)
29	GND	Ground	
30	GND	Ground	

[Note]

\*1) The Overdrive lookup table should be selected in accordance to the frame rate to optimize image quality.

OD SEL (Pin 6)	Note
GND	Lookup table was optimized for 50Hz frame rate
NC	Lookup table was optimized for 60Hz frame rate

\*2) LVDS Option (DMS):

DMS (Pin 9)	LVDS format
Low /Open	Non-JEIDA (Normal)
High (3.3V)	JEIDA

\*3) Reserved for internal use. Must be open.

**4.2 LVDS INTERFACE:****LVDS RECEIVER: Tcon (LVDS Rx merged)**

	<b>LVDS pin</b>	<b>JEIDA-DATA</b>	<b>Non-JEIDA-DATA</b>
TxOUT/RxIN0	TxIN/RxOUT0	R2	R0
	TxIN/RxOUT1	R3	R1
	TxIN/RxOUT2	R4	R2
	TxIN/RxOUT3	R5	R3
	TxIN/RxOUT4	R6	R4
	TxIN/RxOUT6	R7	R5
	TxIN/RxOUT7	G2	G0
TxOUT/RxIN1	TxIN/RxOUT8	G3	G1
	TxIN/RxOUT9	G4	G2
	TxIN/RxOUT12	G5	G3
	TxIN/RxOUT13	G6	G4
	TxIN/RxOUT14	G7	G5
	TxIN/RxOUT15	B2	B0
	TxIN/RxOUT18	B3	B1
TxOUT/RxIN2	TxIN/RxOUT19	B4	B2
	TxIN/RxOUT20	B5	B3
	TxIN/RxOUT21	B6	B4
	TxIN/RxOUT22	B7	B5
	TxIN/RxOUT24	Hsync	Hsync
	TxIN/RxOUT25	Vsync	Vsync
	TxIN/RxOUT26	DENA	DENA
TxOUT/RxIN3	TxIN/RxOUT27	R0	R6
	TxIN/RxOUT5	R1	R7
	TxIN/RxOUT10	G0	G6
	TxIN/RxOUT11	G1	G7
	TxIN/RxOUT16	B0	B6
	TxIN/RxOUT17	B1	B7
	TxIN/RxOUT23	Reserved	Reserved

**4.3 INVERTER – CONNECTOR:**

Connector (Receptacle): S14B-PH-SM3-TB (JST) or compatible

Mating connector (Plug): PRH-14 (JST) or compatible

Pin No.	Symbol	Description	Note
1	VBL	Supply Voltage 24V	
2	VBL	Supply Voltage 24V	
3	VBL	Supply Voltage 24V	
4	VBL	Supply Voltage 24V	
5	VBL	Supply Voltage 24V	
6	GND	Ground	
7	GND	Ground	
8	GND	Ground	
9	GND	Ground	
10	GND	Ground	
11	NC	NC (Test pin or else)	
12	B/L ON/ OFF	B/L On: NC /High (2.0~5.0V) B/L Off: GND (0~0.8V)	
13	PDIM	External PWM or Internal PWM with Analog Input ( Min.:0V; Max: 3.3V)	(1)
14	Vsel	GND: External PWM Dimming (Pin 13) NC /High: Internal PWM with Analog Input (Pin 13)	(2)

**[Note]**

- \*1) VDIM is External PWM control or Analog control input; i.e. External PWM should be able to control width of Voltage Burst of inverter output for Lamp Driving. This input can have two types of input; ordinary default setting will be DC level signal using Saw Tooth Wave control for PWM duty control. The other setting is Duty Signal input with 3.3V TTL specification. These two methods should be decided by 14<sup>th</sup> Pin input setting.
- \*2) 14<sup>th</sup> Pin is selection pin for PWM control method; if this pin is connected to GND, PDIM input of 13<sup>th</sup> Pin should have Logic Level Duty Signal for PWM control. If this is set to High or NC, 13<sup>th</sup> Pin should have DC level signal.

## 5. INTERFACE TIMING (DE only mode)

### 5.1 TIMING SPECIFICATION

ITEM		SYMBOL	MIN.	TYP.	MAX.	UNIT		
LCD Timing	DCLK	Freq.	$f_{CLK}$	62	80	84	MHz	
		Cycle	$t_{CLK}$	14.7	12.5	11.9	ns	
	DENA	Horizontal	Line Rate	$f_H$	37.1	48.6	56	kHz
			Horizontal Total Time	$t_H$	1575	1648	1936	$t_{CLK}$
			Horizontal Effective Time	$t_{HA}$	1366	1366	1366	$t_{CLK}$
			Horizontal Blank Time	$t_{HB}$	209	282	570	$t_{CLK}$
	DENA	Vertical	Frame Rate	Fr	47	60	63	Hz
			Vertical Total Time	$t_V$	790	810	888	$t_H$
			Vertical Effective Time	$t_{VA}$	768	768	768	$t_H$
			Vertical Blank Time	$t_{VB}$	22	42	120	$t_H$
	Sync Mode	Horizontal	Horizontal sync time	$t_{Hsync}$	--	136	--	$t_{CLK}$
			Horizontal Back porch	$t_{HBP}$	--	108	--	$t_{CLK}$
		Vertical	Vertical sync time	$t_{Vsync}$	--	5	--	$t_H$
			Vertical Back porch	$t_{VBP}$	--	22	--	$t_H$

[Note]

\*1) The best result of over-driving is in frame rate =60Hz.

\*2) PAL: 47~53Hz, NTSC: 57~63Hz.

\*3) Vsync and Hsync should be keep the above specification.

### 5.2 TIMING CHART

#### a. Horizontal Timing

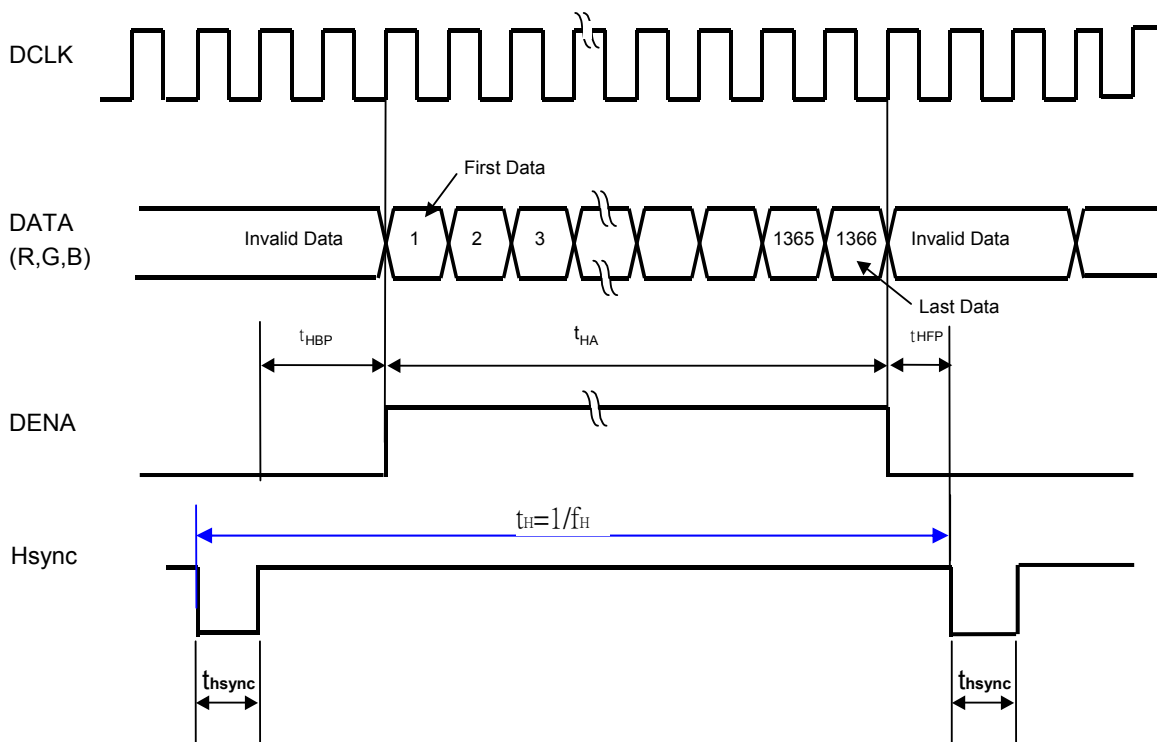

#### b. Vertical Timing Chart

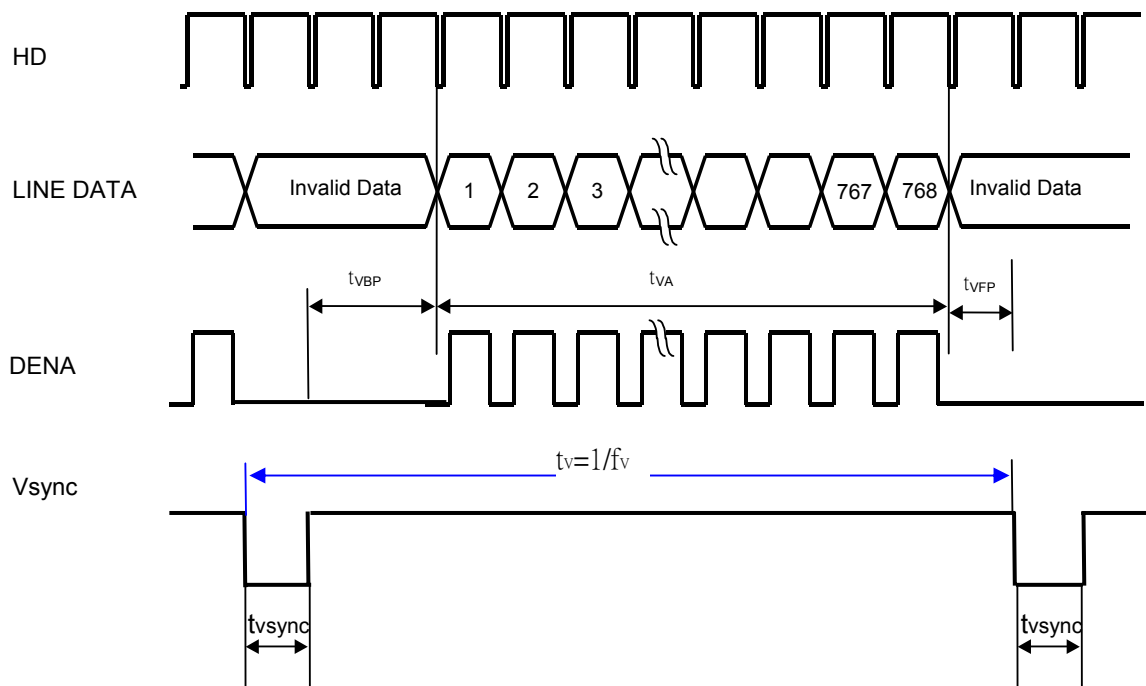

### 5.3 LVDS DATA MAPPING

#### a. None-JEIDA Normal Specification

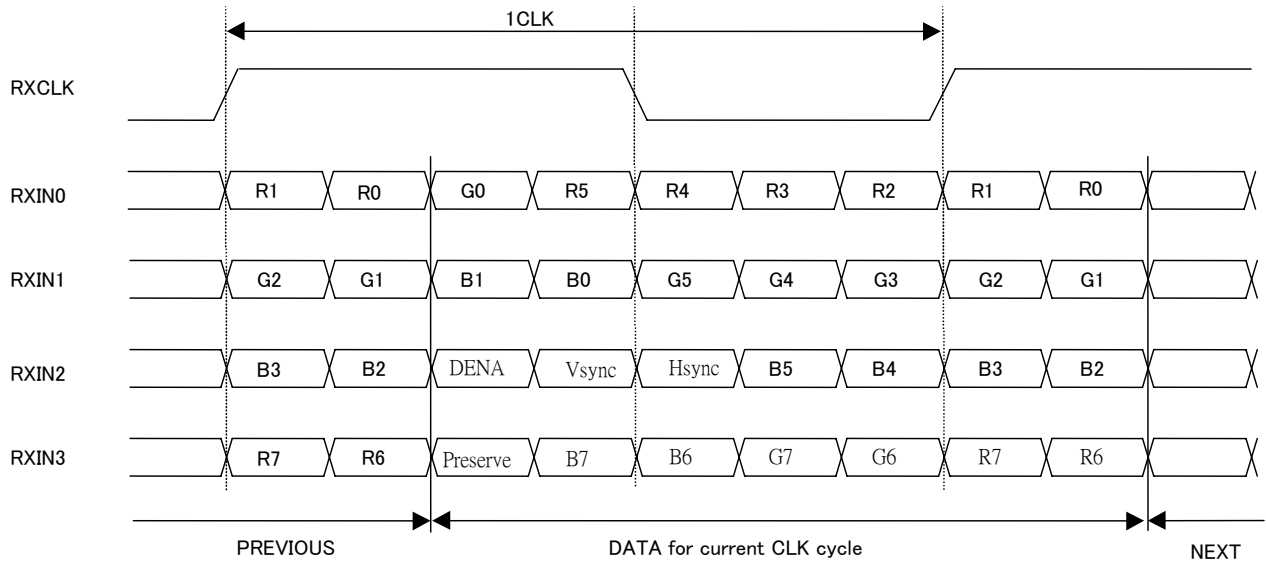

#### b. JEIDA Specification

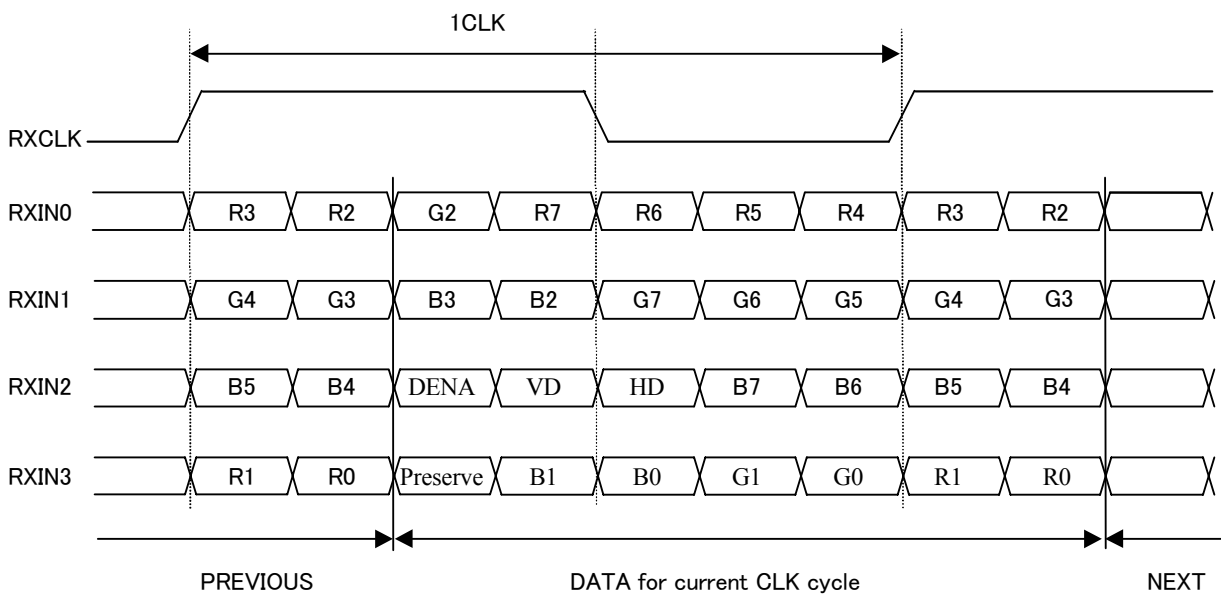

8bit LSB:R0,G0,B0

Parallel TTL Data Inputs Mapped to LVDS Outputs

**5.4 LVDS INTERFACE**

8bit LSB: R0, G0, B0

JEIDA: Parallel TTL Data Inputs Mapped to LVDS Outputs

TRANSMITTER(THC63LVD823)		INTERFACE CONNECTOR		TIMING CONTROLLER INPUT
PIN NO	INPUT DATA	HOST	TFT_LCD	
51	TA0	TxOUT0+ TxOUT0-	RxIN0+ RxIN0-	R2
52	TA1			R3
54	TA2			R4
55	TA3			R5
56	TA4			R6
3	TA5			R7 (MSB)
4	TA6			G2
6	TB0	TxOUT1+ TxOUT1-	RxIN1+ RxIN1-	G3
7	TB1			G4
11	TB2			G5
12	TB3			G6
14	TB4			G7 (MSB)
15	TB5			B2
19	TB6			B3
20	TC0	TxOUT2+ TxOUT2-	RxIN2+ RxIN2-	B4
22	TC1			B5
23	TC2			B6
24	TC3			B7 (MSB)
27	TC4			Hsync
28	TC5			Vsync
30	TC6			DENA
50	TD0	TxOUT3+ TxOUT3-	RxIN3+ RxIN3-	R0 (LSB)
2	TD1			R1
8	TD2			G0 (LSB)
10	TD3			G1
16	TD4			B0 (LSB)
18	TD5			B1
25	TD6			Reserved



5.5 COLOR DATA ASSIGNMENT

COLOR	INPUT DATA	B DATA								G DATA								R DATA							
		B7	B6	B5	R4	B3	R2	R1	R0	G7	G6	G5	G4	G3	G2	G1	G0	R7	R6	R5	R4	B3	R2	R1	R0
		MSE							ISE	MSE							ISE	MSE							ISE
BASIC COLOR	BLACK	0	0	0	0	0	0	0	0	0	0	0	0	0	0	0	0	0	0	0	0	0	0	0	0
	RED(255)	1	1	1	1	1	1	1	1	0	0	0	0	0	0	0	0	0	0	0	0	0	0	0	0
	GREEN(255)	0	0	0	0	0	0	0	0	1	1	1	1	1	1	1	1	0	0	0	0	0	0	0	0
	BLUE(255)	0	0	0	0	0	0	0	0	0	0	0	0	0	0	0	0	1	1	1	1	1	1	1	1
	CYAN	0	0	0	0	0	0	0	0	1	1	1	1	1	1	1	1	1	1	1	1	1	1	1	1
	MAGENTA	1	1	1	1	1	1	1	1	0	0	0	0	0	0	0	0	1	1	1	1	1	1	1	1
	YELLOW	1	1	1	1	1	1	1	1	1	1	1	1	1	1	1	1	0	0	0	0	0	0	0	0
	WHITE	1	1	1	1	1	1	1	1	1	1	1	1	1	1	1	1	1	1	1	1	1	1	1	1
RED	RED(0)	0	0	0	0	0	0	0	0	0	0	0	0	0	0	0	0	0	0	0	0	0	0	0	0
	RED(1)	0	0	0	0	0	0	0	1	0	0	0	0	0	0	0	0	0	0	0	0	0	0	0	0
	RED(2)	0	0	0	0	0	0	1	0	0	0	0	0	0	0	0	0	0	0	0	0	0	0	0	0
	RED(253)	1	1	1	1	1	1	0	1	0	0	0	0	0	0	0	0	0	0	0	0	0	0	0	0
	RED(254)	1	1	1	1	1	1	1	0	0	0	0	0	0	0	0	0	0	0	0	0	0	0	0	0
	RED(255)	1	1	1	1	1	1	1	1	0	0	0	0	0	0	0	0	0	0	0	0	0	0	0	0
GREEN	GREEN(0)	0	0	0	0	0	0	0	0	0	0	0	0	0	0	0	0	0	0	0	0	0	0	0	0
	GREEN(1)	0	0	0	0	0	0	0	0	0	0	0	0	0	0	0	1	0	0	0	0	0	0	0	0
	GREEN(2)	0	0	0	0	0	0	0	0	0	0	0	0	0	0	1	0	0	0	0	0	0	0	0	0
	GREEN(253)	0	0	0	0	0	0	0	0	1	1	1	1	1	1	0	1	0	0	0	0	0	0	0	0
	GREEN(254)	0	0	0	0	0	0	0	0	1	1	1	1	1	1	1	0	0	0	0	0	0	0	0	0
	GREEN(255)	0	0	0	0	0	0	0	0	1	1	1	1	1	1	1	1	0	0	0	0	0	0	0	0
BLUE	BLUE(0)	0	0	0	0	0	0	0	0	0	0	0	0	0	0	0	0	0	0	0	0	0	0	0	0
	BLUE(1)	0	0	0	0	0	0	0	0	0	0	0	0	0	0	0	0	0	0	0	0	0	0	0	1
	BLUE(2)	0	0	0	0	0	0	0	0	0	0	0	0	0	0	0	0	0	0	0	0	0	0	1	0
	BLUE(253)	0	0	0	0	0	0	0	0	0	0	0	0	0	0	0	0	1	1	1	1	1	1	0	1
	BLUE(254)	0	0	0	0	0	0	0	0	0	0	0	0	0	0	0	0	1	1	1	1	1	1	1	0
	BLUE(255)	0	0	0	0	0	0	0	0	0	0	0	0	0	0	0	0	1	1	1	1	1	1	1	1

[Note]

1) Definition of gray scale:

Color (n): n indicates gray scale level, higher n means brighter level.

2) Data: 1-High, 0-Low

### 6. BLOCK DIAGRAM

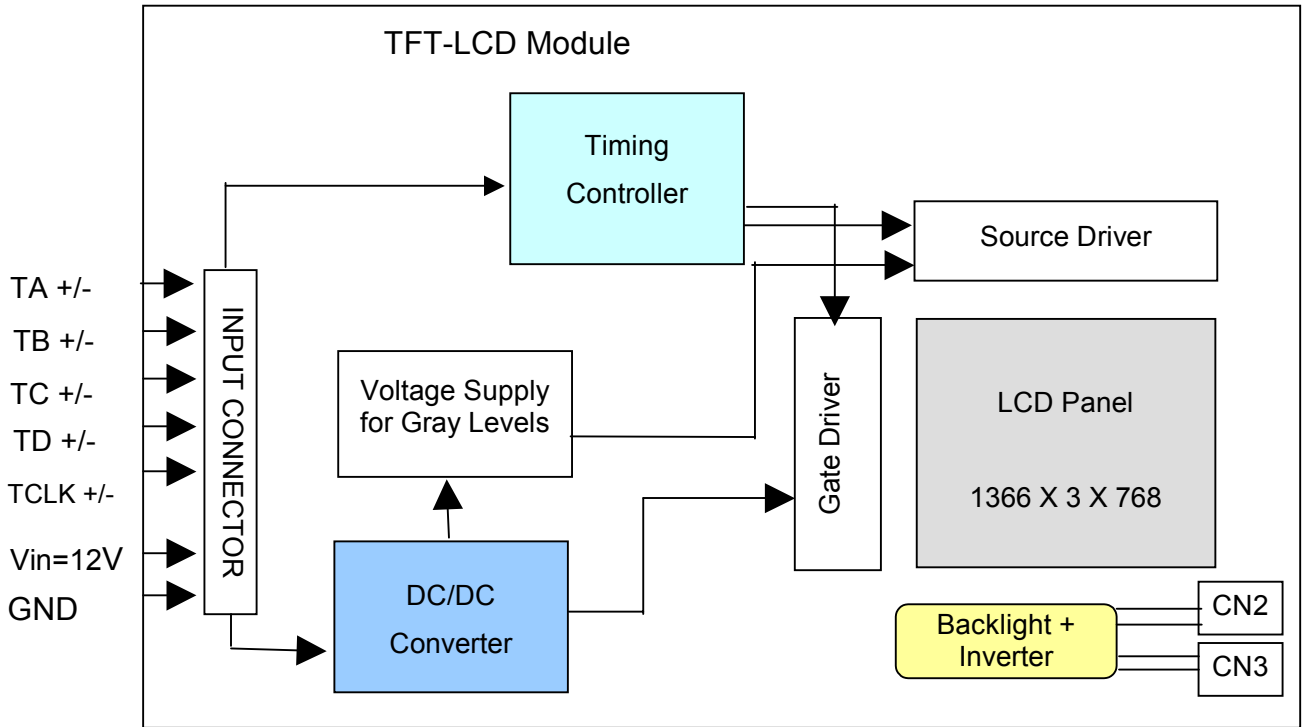

### BACKLIGHT UNIT

Lamp connector

HV: BHR-02VS-1(JST)\*8 or compatible

Mating connector: SM02 (8.0) B-BHS-1-TB (JST) or compatible

LV1: BHR-02VS-1 (JST)\*1 or compatible

Mating connector: SM02 (8.0) B-BHS-1-TB (JST) or compatible

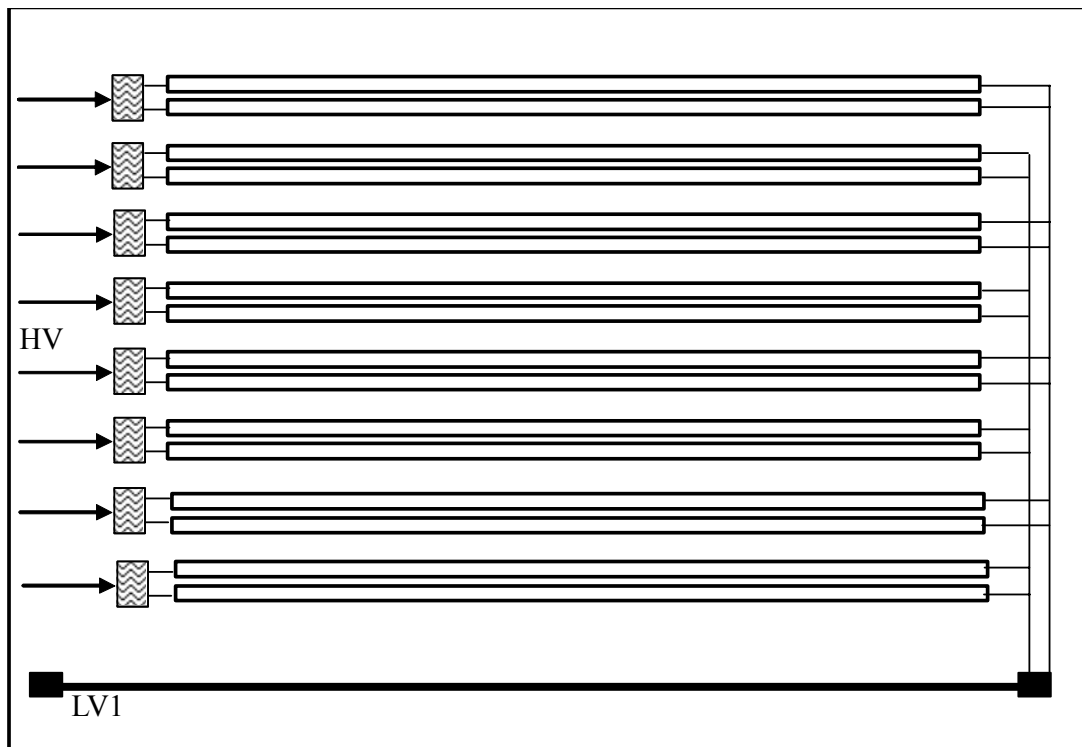

### 7. MECHANICAL SPECIFICATION

7.1 FRONT SIDE ( include inverter, if the sizes of a panel don't show the differential value, please follow the values show as differential range table. )

[Unit: mm]

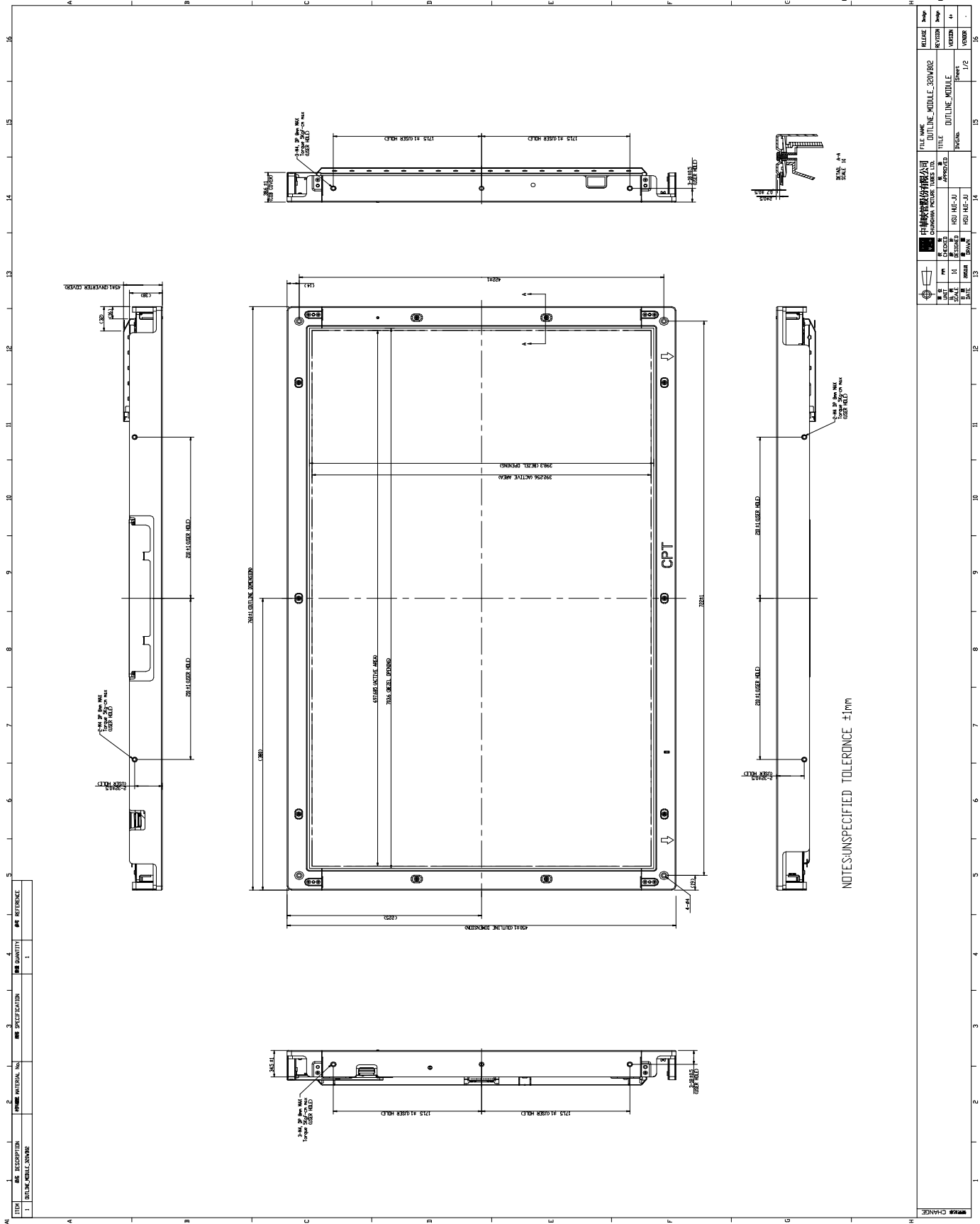

ITEM	DESCRIPTION	UNIT	QUANTITY	REFERENCE
1	INDUSTRIAL SOURCE		1	
2				
3				
4				

FILE NAME	OUTLINE_MIDDLE_SOWBDC	RELEASE	SWP
COMPANY	CHUNGHWA PICTURE TUBES LTD.	REVISION	4
TITLE	OUTLINE MODULE	DATE	11/2
DESIGNER	HSD HUI-JU	APPROVED	
CHECKER			
SCALE	1:1		
DATE			
REVISION			
NO.			
DATE			



## 8.OPTICAL CHARACTERISTICS

Ta = 25°C, VCC=12V ,Turn on for 30 minutes

ITEM		SYMBOL	CONDITION	MIN.	TYP.	MAX.	UNIT	Remarks
Contrast (CEN)		CR	$\theta = \psi = 0^\circ$ Point-5	800	1200	--	--	*1)*2)*3)
Luminance (CEN)	Central Luminance	Lwc	$\theta = \psi = 0^\circ$	400	500		cd/m <sup>2</sup>	*7)
	5P Luminance (AVG)	Lw5	$\theta = \psi = 0^\circ$		450	--	cd/m <sup>2</sup>	*2)*3)
Response Time ( White – Black )		tr	$\theta = \psi = 0^\circ$	--	10	(17)	ms	*3)*4)
		tf	$\theta = \psi = 0^\circ$	--	6	(8)	ms	*3)*4)
Response Time ( Gray to Gray Average )		trg , tfg	$\theta = \psi = 0^\circ$	--	8	(15)	ms	*5)
View Angle	Horizontal	$\psi$	CR $\geq$ 10 Point-5	-80~80	-85~85	--	°	*2)*3)
	Vertical	$\theta$		-80~80	-85~85	--	°	*2)*3)
Color Temperature Coordinate	Red	Rx Ry	$\theta = \psi = 0^\circ$ Point-5	(0.628) (0.283)	(0.658) (0.313)	(0.688) (0.343)	--	*2)*3)
	Green	Gx Gy		(0.255) (0.575)	(0.285) (0.605)	(0.315) (0.635)		
	Blue	Bx By		(0.113) (0.050)	(0.143) (0.080)	(0.173) (0.110)		
	White	Wx Wy		0.253 0.267	0.283 0.297	0.313 0.327		
Color Gamut		CG		--	75	--	%	*6)

## [Note]

These items are measured using: BM-5A (TOPCON)

View angle: EZ contrast XL-88, Response Time: Westar TRD-100

[ under the dark room condition (no ambient light).]

Definition of these measurement items is as follows:

\*1) Definition of Contrast Ratio:

$$CR = \text{ON (White) Luminance} / \text{OFF (Black) Luminance}$$

\*2) Definition of Luminance, Luminance uniformity, Contrast, and the Deviation of Color Coordinate:

Luminance and Contrast: To measure at the center position "5" on the screen (NO.5), see Figure.8-1 below.

Luminance uniformity: Lw (MAX) and Lw(MIN) are the maximum and minimum luminance value measure at the position "1~5" on the screen (NO.1~5), see Figure.8-1 and below show equation:

$$\Delta Lw = [ Lw(\text{MIN}) / Lw(\text{MAX}) ] \times 100\%$$

The Deviation of Color Coordinate: To measure at the position "1~5" on the screen (NO.1~5), see Figure.8-1 below.

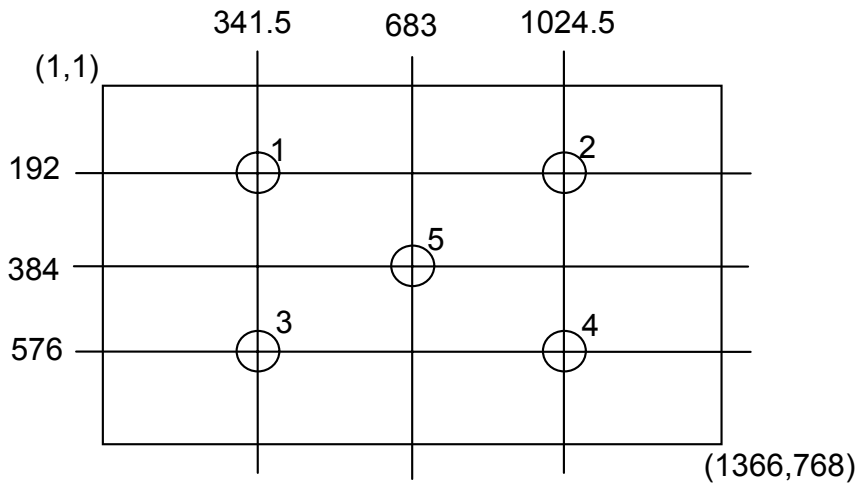

Figure 8-1. Measurement Positions

\*3) Definition of Viewing Angle (  $\theta$ ,  $\phi$  ):

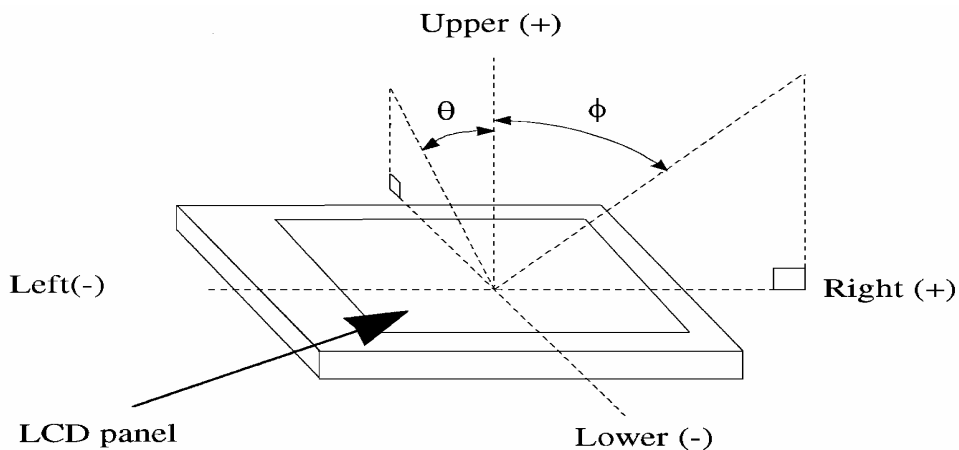

Figure 8-2. Definition of Viewing Angle

\*4) Definition of Response Time ( White – Black )

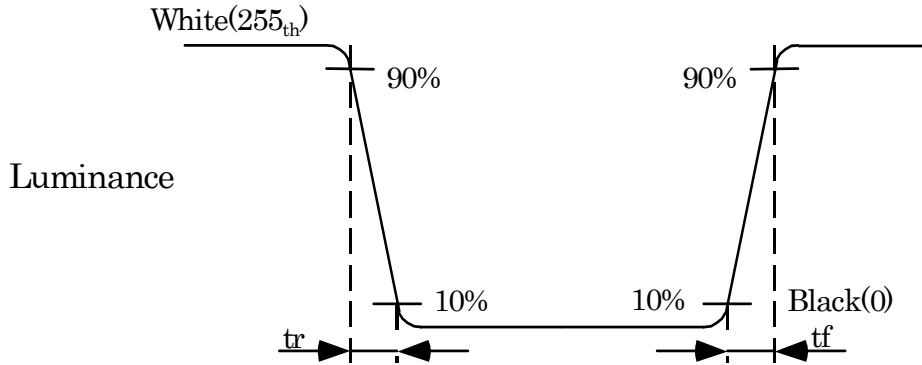

Figure 8-3. Definition of Response Time ( White – Black )

\*5) Definition of Response Time ( Gray to Gray, Average )

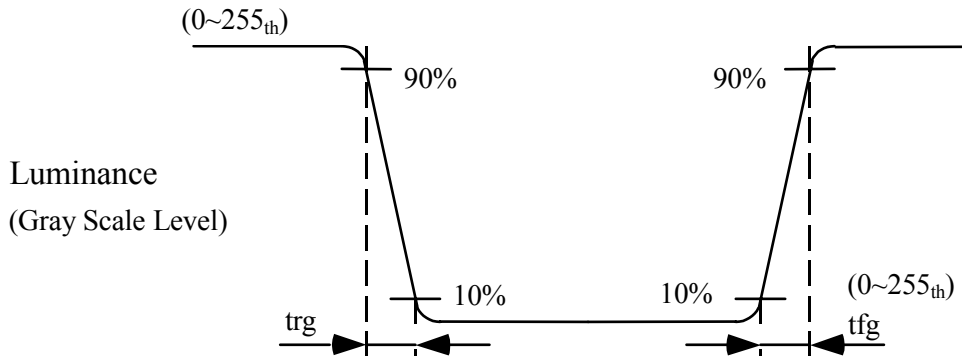

Figure 8-4. Definition of Response Time ( Gray to Gray )

The driving signal time means the signal of gray level 0, 31, 63, 95, 127, 159, 191, 223, 255. Gray to gray average means the average switching time of gray level 0, 31, 63, 95, 127, 159, 191, 223, 255 to each other.

The LCD module should be stabilized at given temperature for 1 hour to avoid abrupt temperature change during measuring. In order to stabilize the luminance, the measurement should be executed after lighting Backlight for 1 hour in a windless room.

\*6) Definition of Color Gamut:

To measure RGB three sub-pixels color gamut coordinate at CIE coordinate chart from the center of module, to form a triangle area =  $A_{RGB}$ .

RGB three sub-pixels of NTSC at CIE coordinate chart to form a triangle area =  $N_{RGB}$ .

$$CG = \frac{A_{RGB}}{N_{RGB}} \times 100$$

\*7) Definition of Central Luminance:

After lighting on the panel 30 mins, you can proceed the Central Luminance testing. The definition of Typ value is under status of Inverter Dimming Voltage=3.3V.

## 9.RELIABILITY TEST CONDITIONS

### 9.1 ENVIRONMENT TEST CONDITION

TEST ITEMS	CONDITIONS
High Temperature storage test	Ta=60°C, 90%RH, 240 hours
Low Temperature storage test	Ta=-20°C, 240 hours
High Temperature operation test	Ta=50°C, 90%RH, 240 hours
Low Temperature operation test	Ta=0°C, 240 hours
Shock Test (Non-Operating)	Shock level: 980m/s <sup>2</sup> (100G) Waveform: half sinusoidal wave, 2ms Direction: ±X, ±Y, ±Z One time in each direction.
Vibration Test (Non-Operating)	Waveform: Sinusoidal Vibration level: 9.8m/s <sup>2</sup> (1.0G) zero to peak Frequency range: 10 - 300 Hz Duration: X,Y,Z, 10 min, total 30 mins One time in each direction

### 9.2 JUDGMENT STANDARD

The judgment of the above test should be made as follow:

Pass: Normal display image with no obvious non-uniformity and no line defect.

Partial transformation of the module parts shall be ignored.

Fail: No display, obvious non-uniformity, or line defects.



## 10.PACKAGING

### 10.1 PACKING SPECIFICATIONS

- (1) 3 LCD TV modules/1 Box
- (2) Box dimensions: 975(L) x 280(W) x 559(H)
- (3) Weight: Approximately 29.6kg (3 modules per box)

### 10.2 PACKING METHOD

Figure 1 and 2 are the packing method

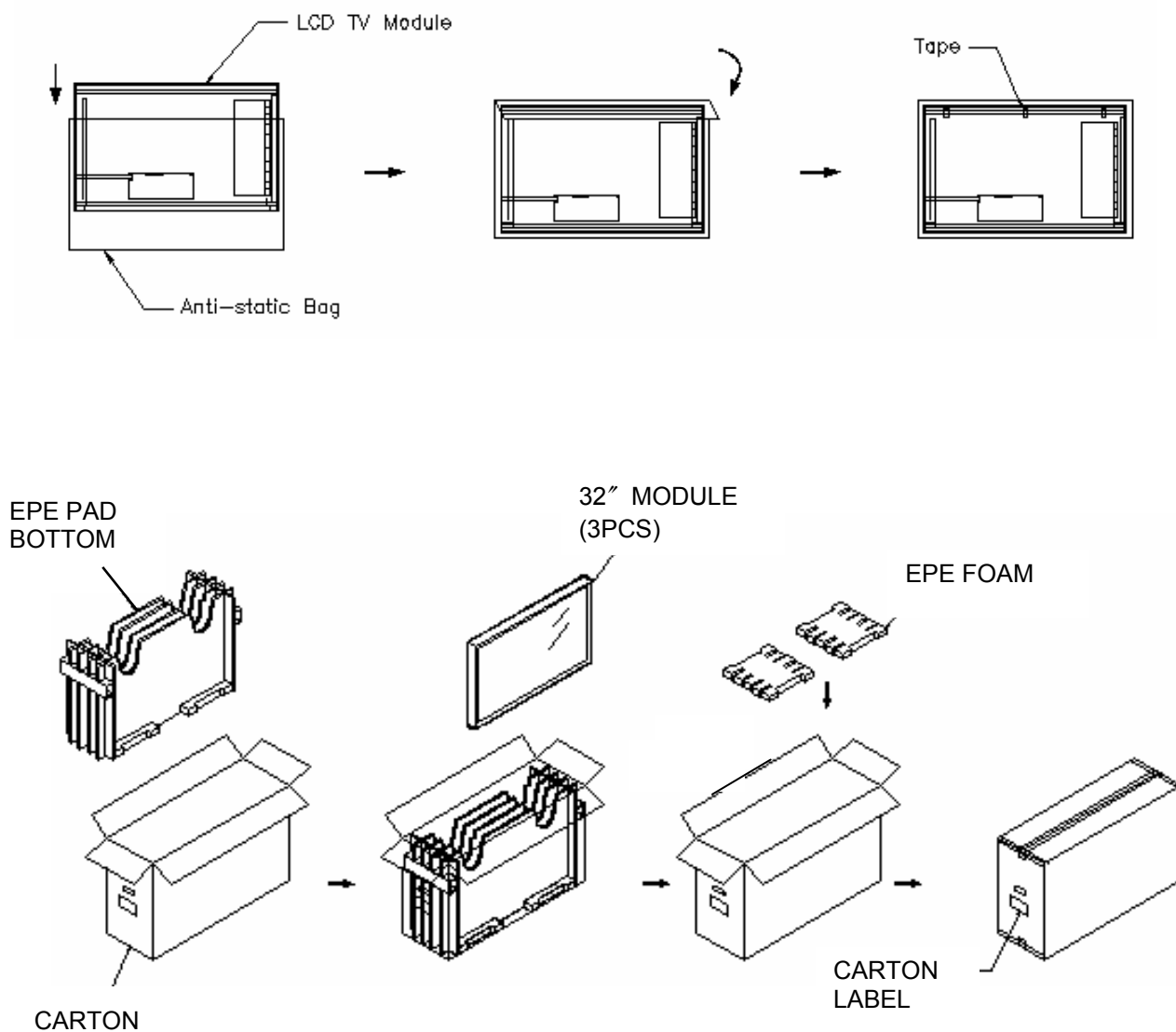

Figure 1 Packing Method

- (1) Corner protector: L1115 x 50mm x 50mm
- (2) Pallet: L1000 x W1150 x H130mm
- (3) Bottom Cap: 1000 x W1150 x H130mm
- (4) Pallet Stack: 1000 x W1150 x H1250mm
- (5) Gross: 251kg

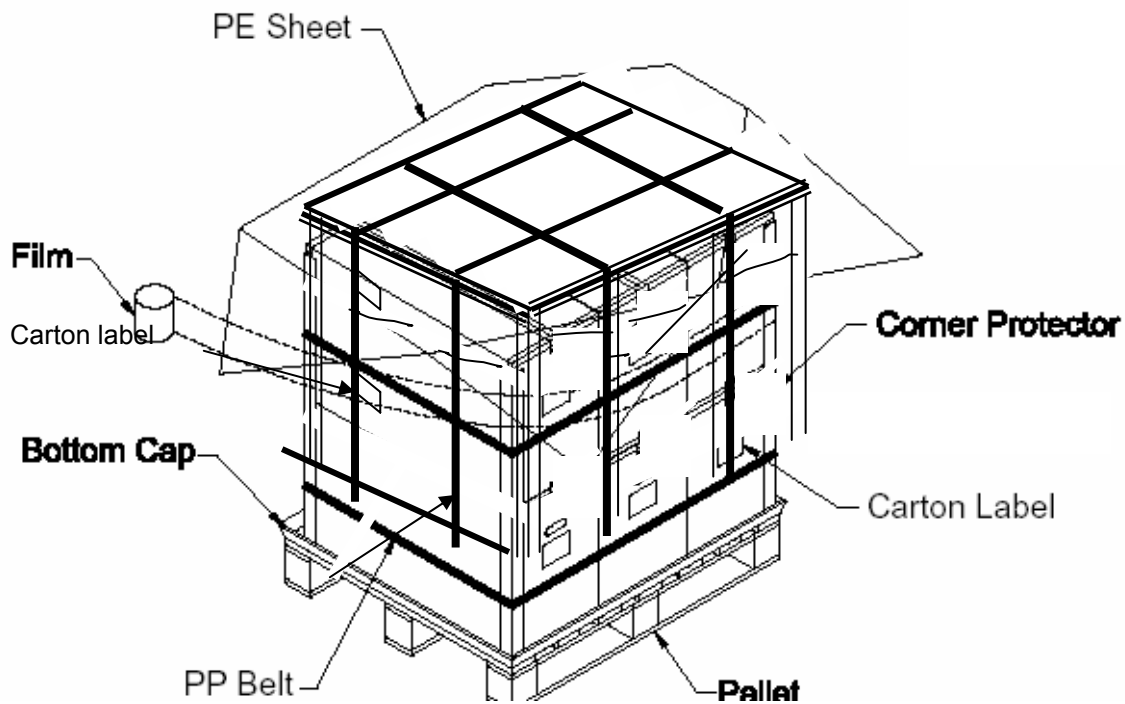

Figure2 Packing Method

## 11. HANDLING PRECAUTIONS FOR TFT-LCD MODULE

Please pay attention to the followings in handling TFT-LCD products.

### 11.1 ASSEMBLY PRECAUTION

- (1) Please use the mounting hole on the module side in installing and do not beading or wrenching LCD in assembling. And please do not drop, bend or twist LCD module in handling.
- (2) Please design display housing in accordance with the following guidelines.
  - Housing case must be destined carefully and do not to put stresses on LCD all sides or wrench module. The stresses may cause non-uniformity even if there is no non-uniformity statically.
  - Keep sufficient clearance between LCD module back surface and housing when the LCD module is mounted. Approximately 1.0 mm of the clearance in the design is recommended taking into account the tolerance of LCD module thickness and mounting structure height on the housing.
  - When some parts, such as, FPC cable and ferrite plate, are installed underneath the LCD module, still sufficient clearance is required, such as 0.5mm. This clearance is, especially, to be reconsidered when the additional parts are implemented for EMI countermeasure.
  - Design the inverter location and connector position carefully so as not to put stress on lamp cable.
  - Keep sufficient clearance between LCD module and the other parts, such as inverter and speaker so as not to interface the LCD module. Approximately 1.0mm of the clearance in the design is recommended.
- (3) Please do not push or scratch LCD panel surface with any-thing hard. And do not soil LCD panel surface by touching with bare hands. ( Polarizer film and surface of LCD panel are easy to be flawed.)
- (4) Please do not press any parts on the rear side such as source TCP, gate TCP, control circuit board and FPC during handling the LCD module. If pressing rear part could not be avoided, handle the LCD module with care not to damage them.
- (5) Please wipe out LCD panel surface with absorbent cotton or soft clothe in case of it being soiled.
- (6) Please wipe out drops of adhesives like saliva and water on LCD panel surface immediately. They might damage to cause panel surface variation and color change.
- (7) Please do not take a LCD module to pieces and reconstruct it. Resolving and reconstructing modules may cause them not to work well.
- (8) Please do not touch metal frames with bare hands and soiled gloves. A color change of the metal frames can happen during a long preservation of soiled LCD modules.

- (9) Please pay attention to handling lead wire of backlight so that it is not tugged in connecting with inverter.

## 11.2 OPERATING PRECAUTIONS

- (1) Please be sure to turn off the power supply before connecting and disconnecting signal input cable.
- (2) Please do not change variable resistance settings in LCD module. They are adjusted to the most suitable value. If they are changed, it might happen LCD does not satisfy the characteristics specification.
- (1) Please consider that LCD backlight takes longer time to become stable of radiation characteristics in low temperature than in room temperature.
- (2) A condensation might happen on the surface and inside of LCD module in case of sudden change of ambient temperature.
- (3) Please pay attention to displaying the same pattern for a very long time. Image might stick on LCD. If then, time going on can make LCD work well.
- (4) Please obey the same caution descriptions as ones that need to pay attention to ordinary electronic parts.

## 11.3 PRECAUTIONS WITH ELECTROSTATICS

- (1) This LCD module use CMOS-IC on circuit board and TFT-LCD panel, and so it is easy to be affected by electrostatics. Please be careful with electrostatics by the way of your body connecting to the ground and so on.
- (2) Please remove protection film very slowly on the surface of LCD module to prevent from electrostatics occurrence.

## 11.4 STORAGE PRECAUTIONS

- (1) When you store LCD for a long time, it is recommended to keep the temperature between 0°C ~40°C without the exposure of sunlight and keep the humidity less than 90%RH.
- (2) Please do not leave the LCD in the environment of high humidity and high temperature such as 60°C 90%RH.
- (3) Please do not leave the LCD in the environment of low temperature(can not lower than -20°C).

## 11.5 SAFETY PRECAUTIONS

- (1) When you waste LCD, it is recommended to crush damaged or unnecessary LCD into pieces and wash them off with solvents such as acetone and ethanol, which should later be burned.
- (2) If any liquid leaks out of a damaged-glass cell and comes in contact with the hands, wash off thoroughly with soap and water.

**11.6 OTHERS**

- (1) A strong incident light into LCD panel might cause display characteristics' changing inferior because of polarizer film, color filter, and other materials becoming inferior. Please do not expose LCD module direct sunlight and strong UV rays.
- (2) Please pay attention on the side of LCD module do not contact with other materials in preserving it alone.
- (3) For the packaging box, please pay attention to the followings:
  - Packaging box and inner case for LCD are designed to protect the LCD from the damage or scratching during transportation. Please do not open except picking LCD up from the box.
  - Please do not pile them up more than 3 boxes. (They are not designed so.) And please do not turn over.
  - Please handle packaging box with care not to give them sudden shock and vibrations. And also please do not throw them up.
  - Packing box and inner case for LCD are made of cardboard. So please pay attention not to get them wet. (Such as keep them away from the high humidity or wet place.)