

# SPECIFICATION FOR 4,0" TFT MODULE WITH TOUCH PANEL

## MMTT040TNWL00004

### REVISION A00

**Customer Approval:**

--

MOMOTech GmbH  
Stawedder 29  
D – 25462 Rellingen / Germany  
P: +49(0)4101 – 8040 – 300  
F: +49(0)4101 – 8040 – 350  
Email: [info@momotech.de](mailto:info@momotech.de)

**REVISION STATUS**

Revision Notice	Description	Page	Rev. Date
0.0	First revision (Tentative)		2007.05.04
0.1	MECHANICAL SPECIFICATION Modify	14	2007.08.17
0.2	(a)Power Voltage 9.OPTICAL CHARACTERISTICS	6 14	2007/11/5

Getronic Only Confidential

## CONTENTS

<b>1. OVERVIEW</b> .....	<b>4</b>
<b>2. ABSOLUTE MAXIMUM RATINGS</b> .....	<b>5</b>
<b>3. ELECTRICAL CHARACTERISTICS</b> .....	<b>5</b>
(a) Power Voltage .....	5
(b) Backlight .....	6
<b>4. PIN ASSIGNMENT</b> .....	<b>7</b>
<b>5. INPUT SIGNAL(DE ONLY MODE)</b> .....	<b>8</b>
(1)Timing Chart.....	8
(2)Timing Specification.....	8
(3) Color Data Assignment .....	9
<b>6. TOUCH PANEL</b> .....	<b>10</b>
(1) ELECTRICAL CHARACTERISTICS :	10
(2) mechanical and reliability characteristics :	11
(3)Design guideline for Touch Panel.....	11
<b>7. BLOCK DIAGRAM</b> .....	<b>12</b>
<b>8. MECHANICAL SPECIFICATION</b> .....	<b>13</b>
(1)Front side.....	13
(2)Back side .....	13
<b>9. OPTICAL CHARACTERISTICS</b> .....	<b>14</b>
<b>10. RELIABILITY TEST CONDITIONS</b> .....	<b>15</b>
(1) Temperature and Humidity .....	15
(2) Shock & Vibration.....	16
(3) Electrostatic Discharge.....	16

## 1. OVERVIEW

This specification is apply for "4"(10.16cm)color TFT-LCD (Thin Film Transistor Liquid Crystal Display) module(pixel number : 480×272)and contain 4 WireResistance touch panel(type name : CLAA040JC06CT) . This module composed of LCD panel,Touch Panel, driver ICs, control circuit and backlight . The 10.16cm ("4") screen produces 480 ×RGB×272 resolution image . By applying 8 bits digital data, 16.7 million color images are displayed on the "4" diagonal screen , Inverter for backlight is not included in this module .

General specification are summarized in the following table :

ITEM	SPECIFICATION
Display Area (mm)	87.84(H) x 49.776(V) (4-inch diagonal )
Number of Pixels	480(H) ×3(RGB)×272(V)
Pixel Pitch (mm)	0.061(H) × 0.183(V)
Color Pixel Arrangement	R,G,B vertical stripe
Display Mode	Normally white, TN
Number of Colors	16.7M
Optimum Viewing Angle	6 o'clock
Brightness (cd/m <sup>2</sup> )	320nit (Typ.)
Viewing Angle   CR ≥ 10	130(H) · 110(V)
Electrical Interface	TTL
Power Consumption (with B/L)(W)	(0.72W) (Typ.)
Module Size (mm)	98.3(W) × 62.6(H) × 6.15(D)
Module Weight (g)	68g (Typ.)
Backlight Unit	LED
Surface Treatment (with Touch Panel)	Anti-Glare · Hardness : 3H
Touch Panel Mode	4 WireResistance

## 2. ABSOLUTE MAXIMUM RATINGS

ITEM	SYMBOL	MIN.	MAX.	UNIT	NOTE
Power Supply Voltage for LCD	VCC	-0.3	6.0	V	
input voltage	V <sub>i</sub>	-0.3	VCC+0.3	V	
Operate Temperature ( sys )	T <sub>opa</sub>	-30	85	°C	
Storage Temperature	T <sub>stg</sub>	-40	95	°C	
Singal LED Forward Current	I <sub>F</sub>	--	30	mA	
Singal LED Pulse Forward Current	I <sub>FP</sub>	--	100	mA	
Singal LED Reverse Current	V <sub>R</sub>	--	5	V	

## 3. ELECTRICAL CHARACTERISTICS

### (a) Power Voltage

Ta=25°C

ITEM	SYMBOL	MIN	TYP	MAX.	UNIT	NOTE
Power Supply Voltage for LCD	VCC	3.0	3.3	3.6	V	[Note1]
LCD Input Current *1)	ICC	-	55	--	mA	[Note2]
Logic Input Voltage	Input Voltage	V <sub>IN</sub>	0	VCC	V	
	Threshold Voltage (High)	V <sub>TH</sub>	0.7VCC	VCC	V	
	Threshold Voltage (Low)	V <sub>TL</sub>	0	0.3VCC	V	

[Note 1] Power · Signal sequence

VCC=3.3V

VCC Condition :

$1\text{ms} < t_1 \leq 10\text{ms}$

$0 < t_2 \leq 50\text{ms}$

$0 < t_3 \leq 50\text{ms}$

$0 < t_4 \leq 10\text{ms}$

$1\text{sec} \leq t_5$

[Note 2]

TYP range are 0~63 Gray scale

Pattern shown value

272 line mode

VCC= +3.3V

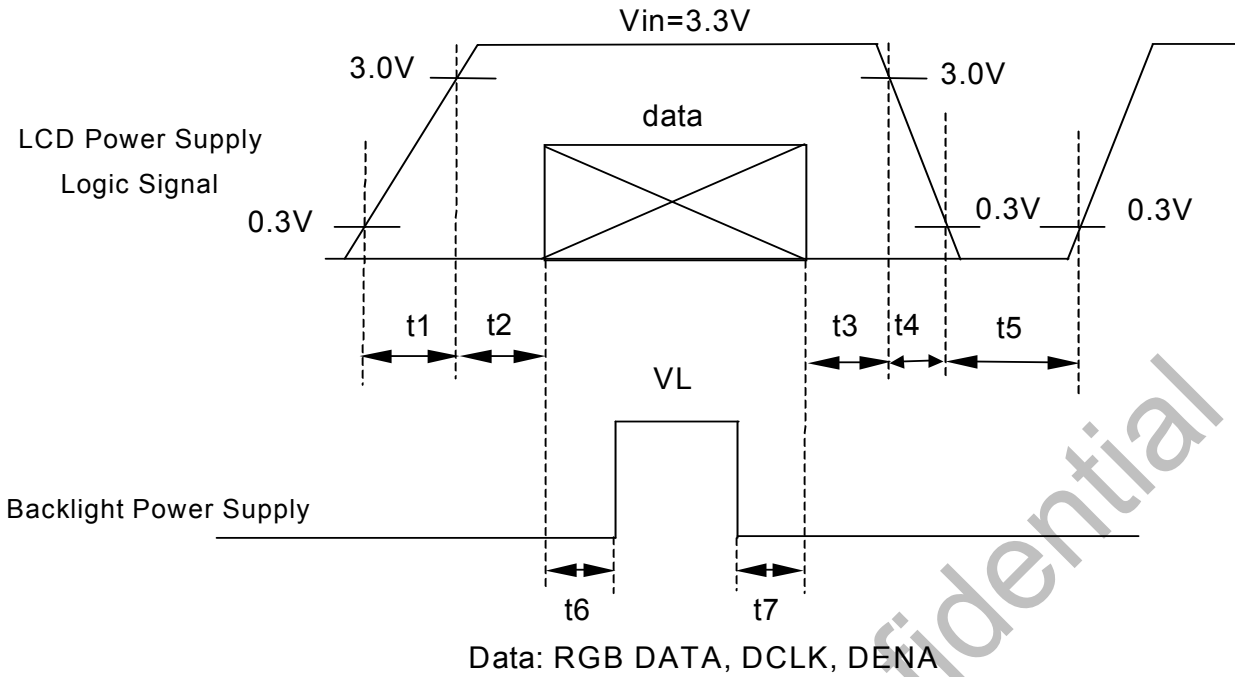

$t_1 \leq 10ms$        $1 \text{ sec} \leq t_5$   
 $50ms \leq t_2$        $200ms \leq t_6$   
 $0 < t_3 \leq 50ms$        $200ms \leq t_7$   
 $0 < t_4 \leq 10ms$

(b) Backlight

$T_a=25^\circ C$

ITEM	SYMBOL	MIN	STANDARD	MAX.	UNIT	NOTE
LED Voltage	$V_L$	--	23.1	25.5	V	$I_L=23.0 \text{ mA}$
LED Current	$I_L$	--	23.0	--	mA	*1)
Power consumption	$W_L$	--	531.3	--	mW	*2)

[Note]

\*1) LED Current Test Way

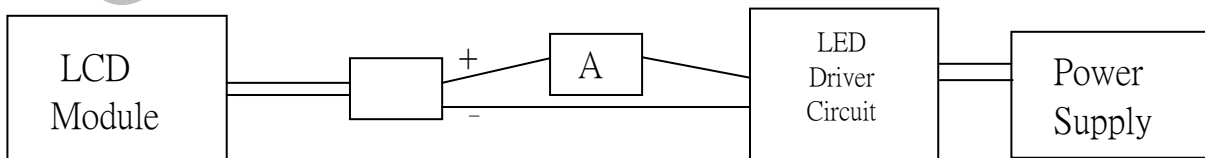

\*2)  $V_L \times I_L$ ,  $I_L=23mA$

**4.PIN ASSIGNMENT**

Pin NO.	SYMBOL	DESCRIPTION	Remark
1	VSS	Ground	
2	VSS	Ground	
3	Vcc	Power Supply	
4	Vcc	Power Supply	
5	R0	Red Data Bit 0	
6	R1	Red Data Bit 1	
7	R2	Red Data Bit 2	
8	R3	Red Data Bit 3	
9	R4	Red Data Bit 4	
10	R5	Red Data Bit 5	
11	R6	Red Data Bit 6	
12	R7	Red Data Bit 7	
13	G0	Green Data Bit0	
14	G1	Green Data Bit1	
15	G2	Green Data Bit2	
16	G3	Green Data Bit3	
17	G4	Green Data Bit4	
18	G5	Green Data Bit5	
19	G6	Green Data Bit6	
20	G7	Green Data Bit7	
21	B0	Blue Data Bit0	
22	B1	Blue Data Bit1	
23	B2	Blue Data Bit2	
24	B3	Blue Data Bit3	
25	B4	Blue Data Bit4	
26	B5	Blue Data Bit5	
27	B6	Blue Data Bit6	
28	B7	Blue Data Bit7	
29	Vss	Ground	
30	DCLK	Dot Data Clock	
31	DISP	Display/On/Off	Note1
32	Hsync	Horizotal Sync Input	
33	Vsync	Vertical Sync Input	
34	DE	Data Enable Control	Note2
35	U/D	Shift up or down Control	Note3
36	L/R	Shift Left or Right Control	Note3
37	Vss	Ground	
38	Vss	Ground	
39	X1	Right(TP)	
40	Y1	Bottom(TP)	
41	X2	Left(TP)	
42	Y2	UP(TP)	
43	Vss	Ground	
44	Vss	Ground	
45	Vss	Ground	
46	VLED-	LED Ground	
47	VLED+	LED Power	
48	Vss	Ground	
49	Vss	Ground	
50	Vss	Ground	

Note1 : DISP set High, input data are valid. DISP set Low, input data are invalid.

Note2 : DE is High, data can be access. DE is Low, data can not be access.

Note3 : U/D set High→UP to Down. U/D set Low→Down to UP.

L/R set High→Left to Right. L/R set Low→Right to Left

### 5. INPUT SIGNAL(DE ONLY MODE)

#### (1)Timing Chart

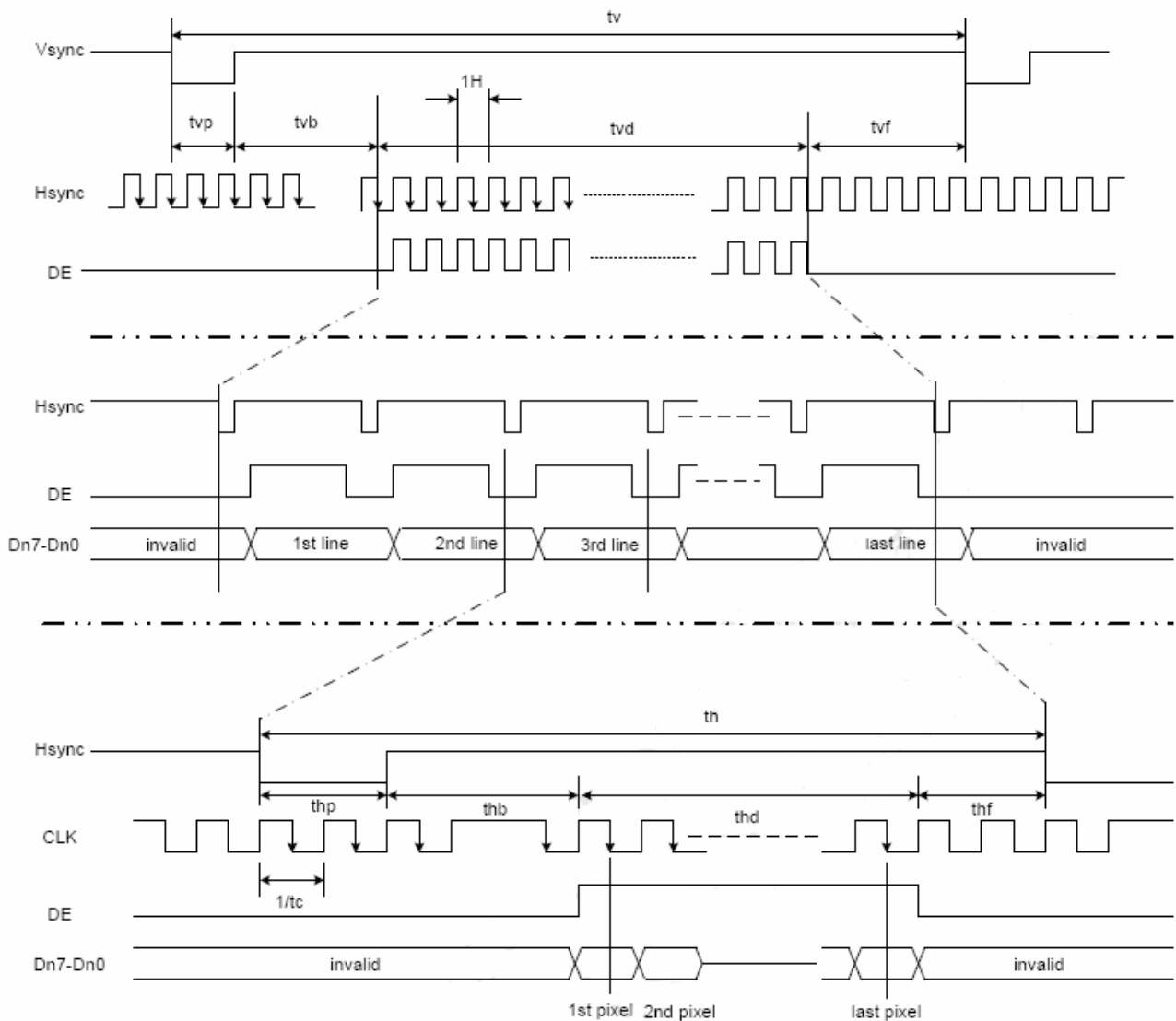

#### (2)Timing Specification

ITEM	SYMBOL	MIN	TYP	MAX	UNIT
CLK/Hsync/Vsync	CLK cycle	$t_{CLK}$	--	9	MHz
	Hsync cycle	$1/th$	--	17.14	kHz
	Vsync cycle	$1/tv$	--	59.94	Hz
Horizontal cycle	Horizontal cycle	$th$	--	525	CLK
	Horizontal display period	$thd$	--	480	CLK
	Horizontal front porch	$thf$	2	--	CLK
	Horizontal pulse width	$thp$	2	41	CLK
	Horizontal back porch	$thb$	2	2	CLK
Vertical cycle	Vertical cycle	$tv$	--	286	H
	Vertical display period	$tvd$	--	272	H
	Vertical front porch	$tvf$	1	2	H
	Vertical pulse width	$tvp$	1	10	H
	Vertical back porch	$tvb$	1	2	H



(3) Color Data Assignment

COLOR	INPUT DATA	R DATA								G DATA								B DATA							
		R7	R6	R5	R4	R3	R2	R1	R0	G7	G6	G5	G4	G3	G2	G1	G0	B7	B6	B5	B4	B3	B2	B1	B0
		MSB				LSB				MSB				LSB				MSB				LSB			
BASIC COLOR	BLACK	0	0	0	0	0	0	0	0	0	0	0	0	0	0	0	0	0	0	0	0	0	0	0	0
	RED(255)	1	1	1	1	1	1	1	1	0	0	0	0	0	0	0	0	0	0	0	0	0	0	0	
	GREEN(255)	0	0	0	0	0	0	0	0	1	1	1	1	1	1	1	0	0	0	0	0	0	0	0	
	BLUE(255)	0	0	0	0	0	0	0	0	0	0	0	0	0	0	0	1	1	1	1	1	1	1	1	
	CYAN	0	0	0	0	0	0	0	0	1	1	1	1	1	1	1	1	1	1	1	1	1	1	1	
	MAGENTA	1	1	1	1	1	1	1	1	0	0	0	0	0	0	0	1	1	1	1	1	1	1	1	
	YELLOW	1	1	1	1	1	1	1	1	1	1	1	1	1	1	1	0	0	0	0	0	0	0	0	
	WHITE	1	1	1	1	1	1	1	1	1	1	1	1	1	1	1	1	1	1	1	1	1	1	1	
RED	RED(0)	0	0	0	0	0	0	0	0	0	0	0	0	0	0	0	0	0	0	0	0	0	0	0	
	RED(1)	0	0	0	0	0	0	0	1	0	0	0	0	0	0	0	0	0	0	0	0	0	0	0	
	RED(2)	0	0	0	0	0	0	1	0	0	0	0	0	0	0	0	0	0	0	0	0	0	0	0	
	RED(254)	1	1	1	1	1	1	1	0	0	0	0	0	0	0	0	0	0	0	0	0	0	0	0	
	RED(255)	1	1	1	1	1	1	1	1	0	0	0	0	0	0	0	0	0	0	0	0	0	0	0	
	GREEN	GREEN(0)	0	0	0	0	0	0	0	0	0	0	0	0	0	0	0	0	0	0	0	0	0	0	0
GREEN(1)	0	0	0	0	0	0	0	0	0	0	0	0	0	0	1	0	0	0	0	0	0	0	0		
GREEN(2)	0	0	0	0	0	0	0	0	0	0	0	0	0	1	0	0	0	0	0	0	0	0	0		
GREEN(254)	0	0	0	0	0	0	0	0	1	1	1	1	1	1	0	0	0	0	0	0	0	0	0		
GREEN(255)	0	0	0	0	0	0	0	0	1	1	1	1	1	1	1	0	0	0	0	0	0	0	0		
BLUE	BLUE(0)	0	0	0	0	0	0	0	0	0	0	0	0	0	0	0	0	0	0	0	0	0	0	0	
	BLUE(1)	0	0	0	0	0	0	0	0	0	0	0	0	0	0	0	0	0	0	0	0	0	0	1	
	BLUE(2)	0	0	0	0	0	0	0	0	0	0	0	0	0	0	0	0	0	0	0	0	0	1	0	
	BLUE(254)	0	0	0	0	0	0	0	0	0	0	0	0	0	0	0	1	1	1	1	1	1	1	0	
	BLUE(255)	0	0	0	0	0	0	0	0	0	0	0	0	0	0	0	1	1	1	1	1	1	1	1	

[Note]

- (1) Definition of gray scale  
 Color (n) : n means level of gray scale  
 Larger n means brighter level
- (2)Data: 1-High,0-Low

### 6. TOUCH PANEL

(1) ELECTRICAL CHARACTERISTICS :

ITEM	MIN	TYP	MAX	UNIT	NOTE
Linearity error	-1.5	--	1.5	%	
Resistance Between Terminals *1)	500	--	1500	$\Omega$	X (Film Side)
	200	--	900	$\Omega$	Y (Glass Side)
Insulation Resistance	20M	--	--	$\Omega$	DC 25V
Operation Voltage	--	--	5	V	
Response Time	--	--	10	ms	*2)
Transmittance	--	80	--	%	*3)
Haze	4	8	12	%	*3)

[Note]

\*1)Type : four-wire resistance

\*2)

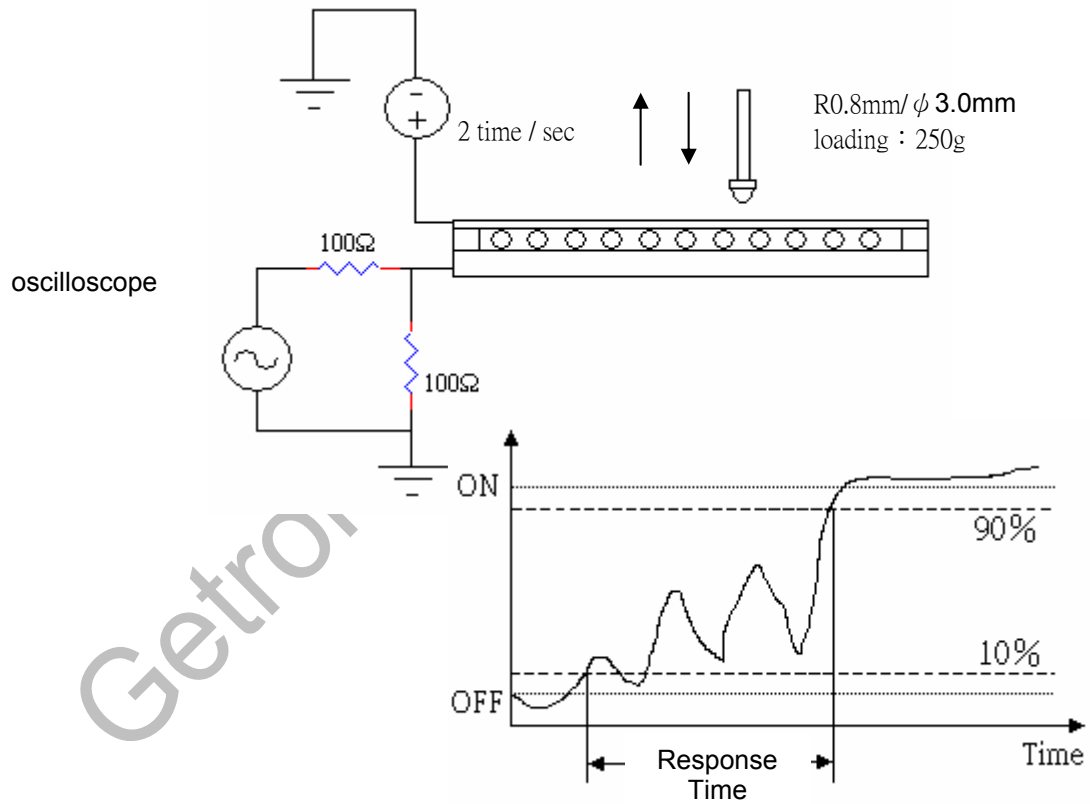

\*3)JIS K7105 · measure equipment=>Haze-gard plus : BYK-Gardner

## (2) mechanical and reliability characteristics :

Item	MIN	TYP	MAX	UNIT	NOTE
lowest. Activation Force	--	--	80	g	*1)
Durability-surface pitting	1,000,000			time	*2)
Durability-surface scratching	100,000			time	*3)
Surface Treatment	3			H	45°/4.9 Nt

## [Note]

\*1) with stylus pen : R 0.8mm/ψ3.0mm 、 with finger : R 8.0mm/ψ12.0mm ◦

\*2) writing with the Silicon Rubbe pen (R 8.0mm/ψ12.0mm) on the same point of the touch panel with 250g force , frequency : 5Hz

\*3) writing with the test pen (R 0.8/ψ3.0mm/POM material) on the touch area of the touch panel with 250g (2.45N) force , moving velocity : 70mm/sec

## (3)Design guideline for Touch Panel

(a)The Housing Cushion on touch-panel must be set at outside of T.P's view-area ◦

(b)The Cushion material must be elastic material.

(c)The housing must avoid to touch the T.P

(d)To combine, the housing should not be stuck on T.P.

(e)Position of Cushino:the distance of left&right of TSP VA aera is up to 2.4mm(only for reference),the distance of TSP VA aera is up to 0.9mm(only for reference),real condition must depend on design value of customer.

(f) 〈 Example of housing design 〉 :

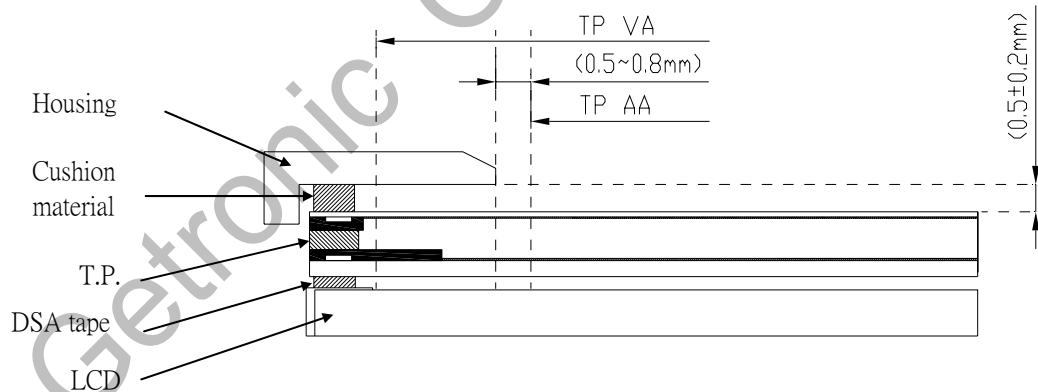

### 7. BLOCK DIAGRAM

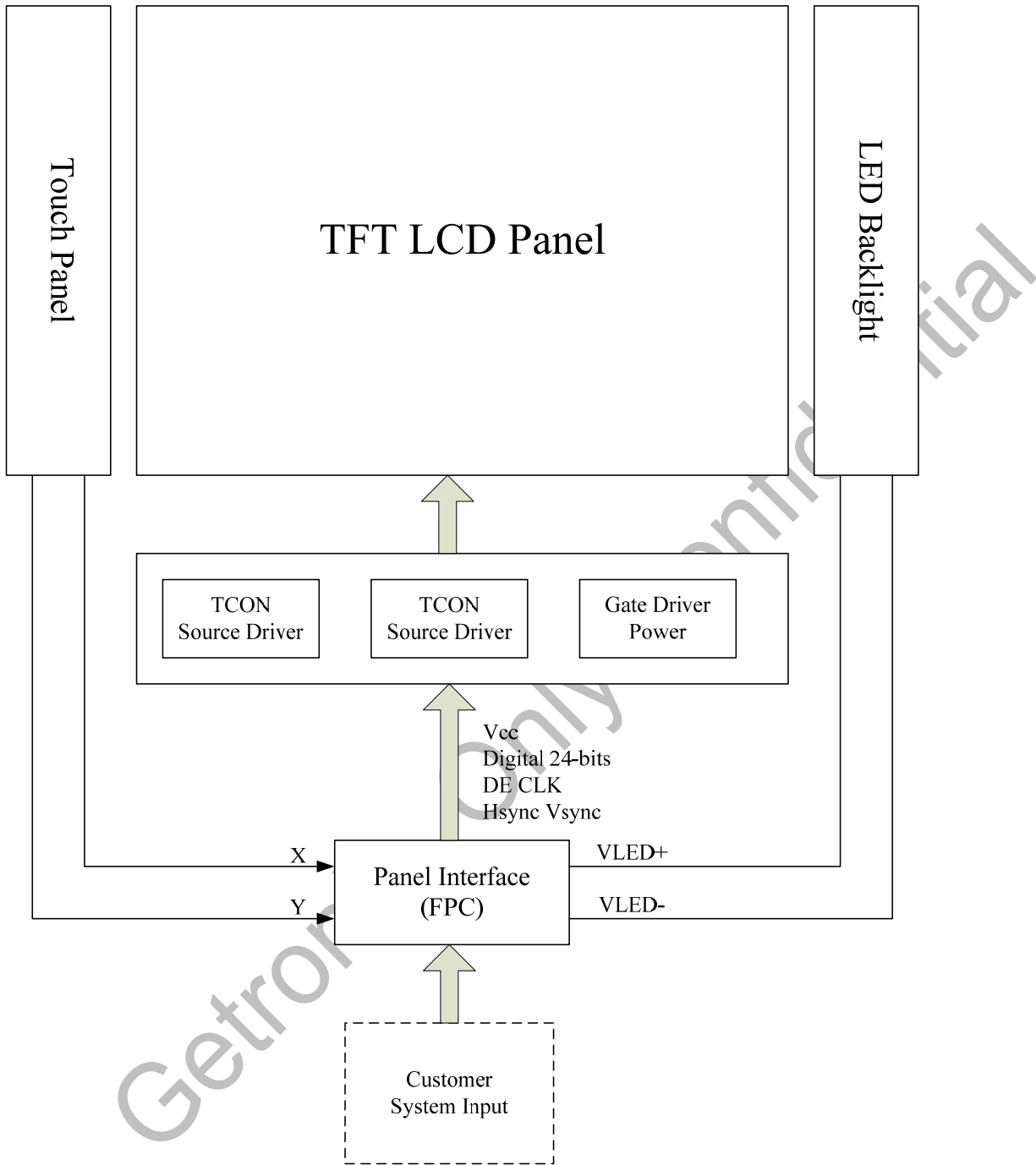

### 8. MECHANICAL SPECIFICATION

(1)Front side

[Unit : mm]

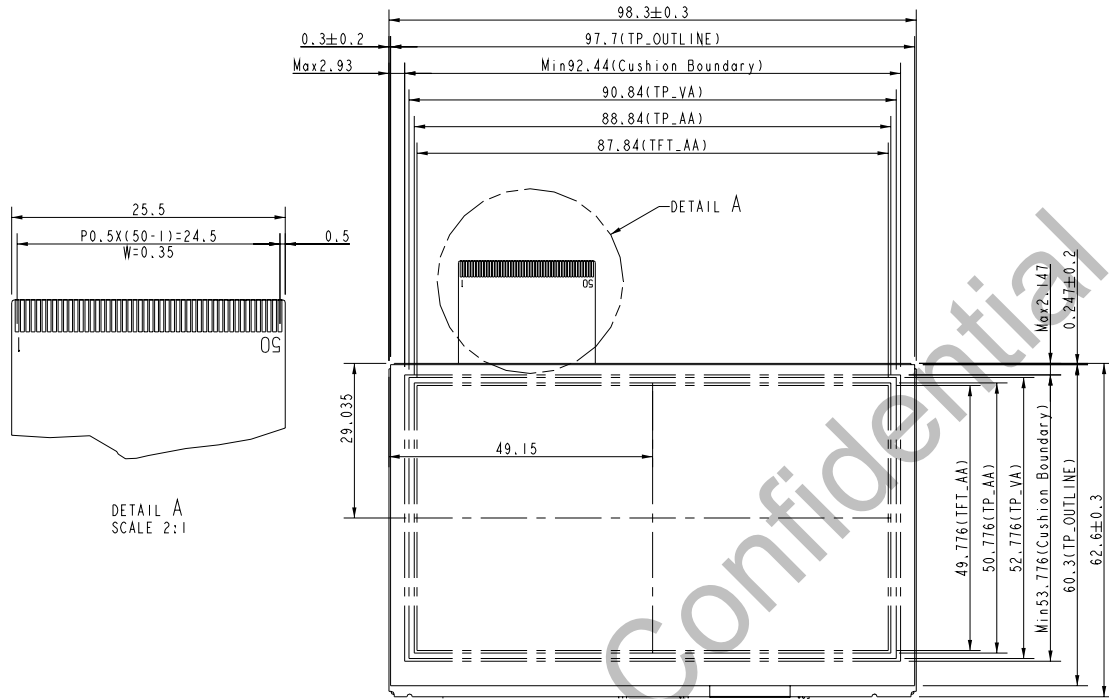

(2)Back side

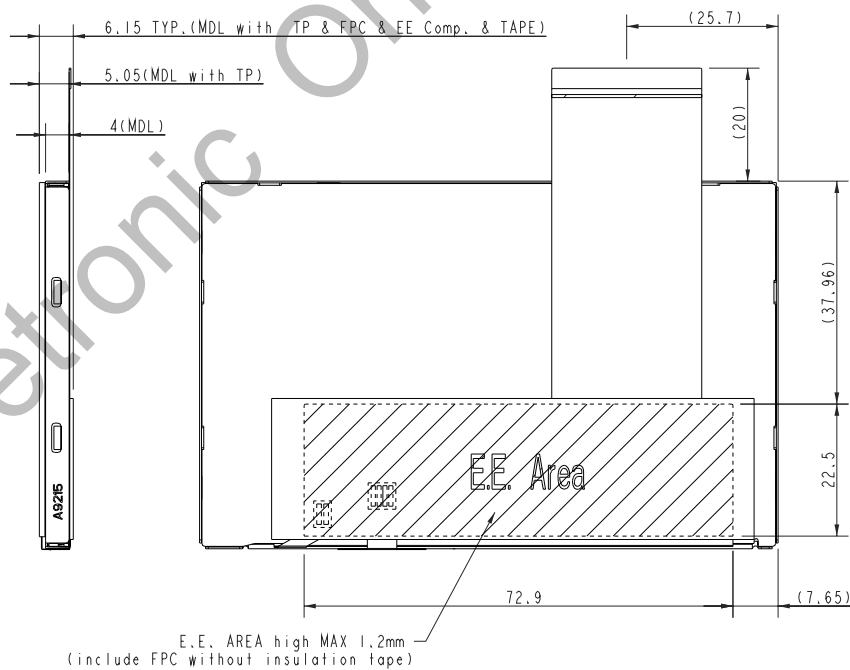

**Note1 : Undefined tolerances to be ±0.3mm**

**Note2 : Total Thickness is 6.15mm (without Tape and Cushion)**

9. OPTICAL CHARACTERISTICS

Ta=25°C

ITEM	SYMBOL	CONDITION	MIN.	TYP.	MAX.	UNIT	Remarks	
Contrast	CR	Point-5	200	300	--	--	*1)	
Luminance	Luminance (CEN)	L	. . . . .	260	320	--	cd/m <sup>2</sup>	*2)
	Luminance Uniformity	L	. . . . .	70	80	--	%	*2)
Color Saturation				45		%		
Response Time	tr+tf	. . . . .	--	25	30	ms	*3)	
View angle	Horizontal	CR 10 Point-5	110	130	--	°	*4)	
	Vertical		90	110	--	°	*4)	
Color Coordinate	White	Wx Wy	0.273 0.289	0.313 0.329	0.353 0.369	--		
			Red	Rx Ry	0.537 0.294	0.577 0.334	0.617 0.374	--
	Green	Gx Gy			0.296 0.543	0.336 0.583	0.376 0.623	--
			Blue	Bx By	0.112 0.0841	0.152 0.124	0.192 0.164	--

[Note] Measure Condition: IL= 23.0mA  
 Measure Item Definition as follow :

\*1) Definition of Contrast Ratio : (Measured by BM-5A (TOPCON) [dark room] )  
 Contrast Ratio (CR)= (White) Luminance of ON ÷ (Black) Luminance of OFF

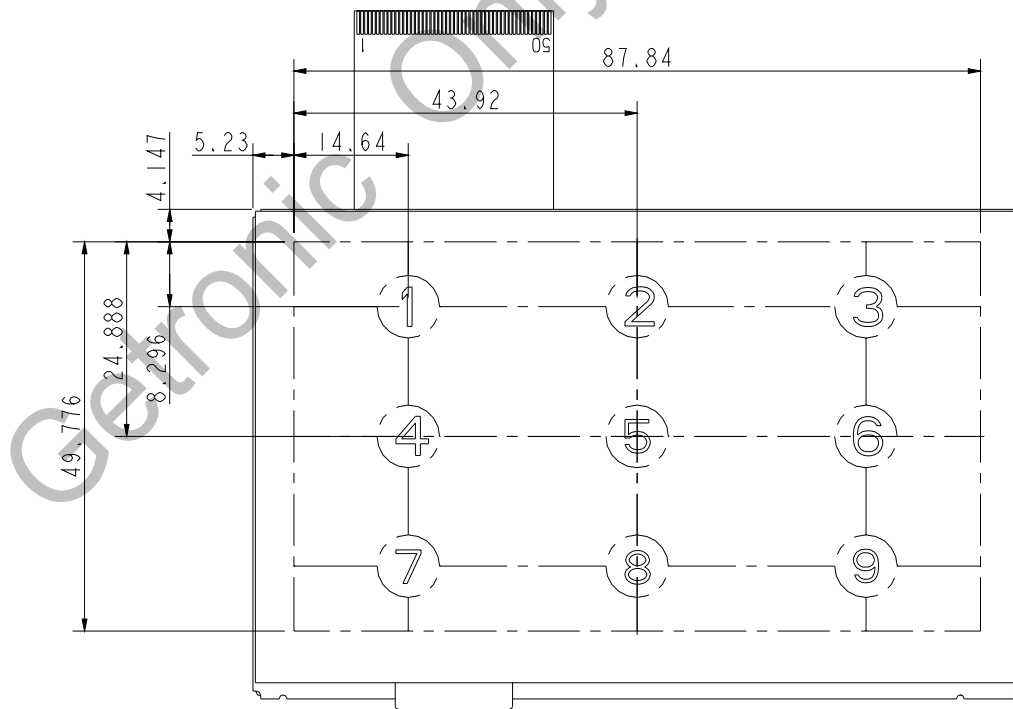

Fig.9-1: Test Point Position

\*2) Definition of Center Luminance & Luminance Uniformity : (Measured by BM-5A (TOPCON) [dark room] )  
 Center Luminance : Measure luminance on Point No5 as figure 9-1.  
 Luminance Uniformity : Measure maximum luminance(L(MAX) )and minimum luminance (L(MIN) )on the 9 points as figure 9-1.  
 $\Delta L = [L(MIN)/L(MAX)] \times 100\%$

\*3) Response Time (White - Black)

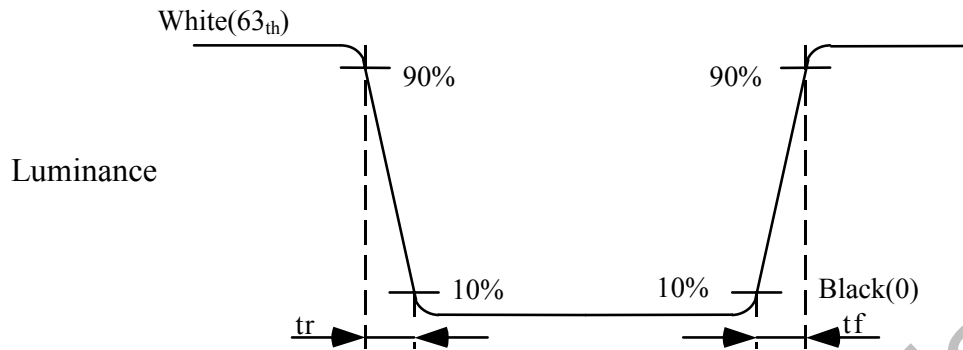

Fig.9-2: Definition of Response Time (White - Black)

\*4) Definition of Viewing Angle.( . . ) : (by EZ-CONTRAST (ELDIM) in the dark room. )

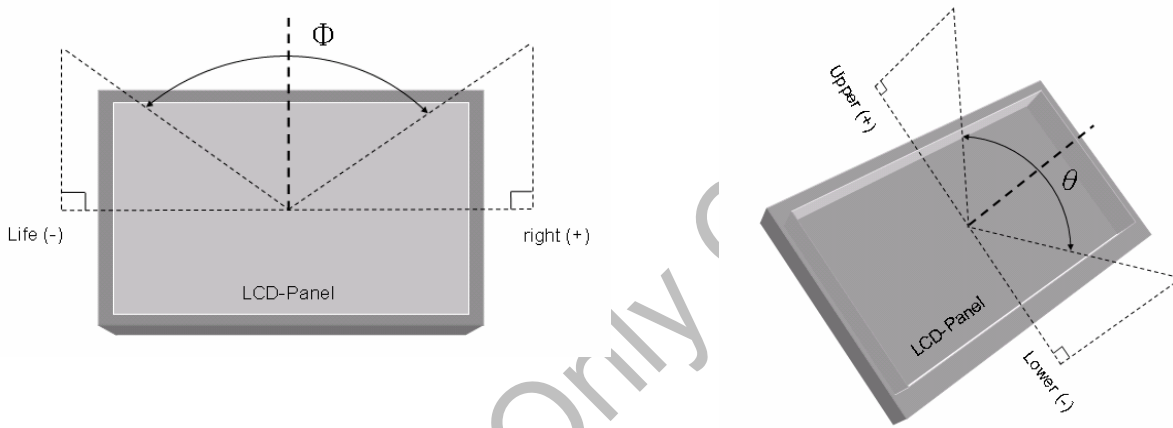

Fig.9-3: Definition of Viewing Angle

**10. RELIABILITY TEST CONDITIONS**

(1) Temperature and Humidity

TEST ITEM	CONDITIONS
High Temperature Operation	85° C ; 240 hrs
High Temperature Storage	95° C ; 240 hrs (TSP : 85° C ; 240 hrs)
High Temperature High Humidity Operation	60° C ; 90% RH ; 240 hrs (No condensation)
Low Temperature Operation	-30° C ; 240 hrs
Low Temperature Storage	-40° C ; 240 hrs
Thermal Shock	-30° C (0.5 hrs)~85° C (0.5 hrs) 200 CYCLE

## (2) Shock &amp; Vibration

TEST ITEM	CONDITIONS
Shock (Non-Operation)	Shock Level: 980m/s <sup>2</sup> (100G), Waveform: half sinusoidal wave Shock Time: 6ms Number of shocks: one shock input in each direction of three mutually perpendicular axes for a total of six shock inputs
Vibration (Non-Operation)	Frequency range:8~33.3Hz Stroke : 1.3 mm Wave Form: sinusoidal wave,perpendicular axis(both x,y,z axis: 2Hrs). Sweep: 2.9G,33.3~400Hz Cycle: 15 min

## (3) Electrostatic Discharge

TEST ITEM	CONDITIONS	Note
ESD	150pF , 330Ω , ±15kV air test	(i)
	200pF , 0Ω , 200V contact test	(ii)

NOTE : Measure point (i)LCD glass and metal bezel  
(ii)IF connector pins

## (4)Pass Judgment Mode

The judgment of the above test should be made as follow:

Pass: Normal display image with no obvious non-uniformity and no line defect.

Fail: No display image, obvious non-uniformity, or line defects.