



Chunghwa Picture Tubes, Ltd.

Product Specification

To :

Date : 090428

TFT LCD

CLAA048LA0BCW

ACCEPTED BY : (V0.2)

Tentative

APPROVED BY	CHECKED BY	PREPARED BY
張聖暉	李家銘	羅宇城

Prepared by :

Small &Medium Product Planning Management Department

Small &Medium Product General Division

CHUNGHWA PICTURE TUBES, LTD.

1127 Hopin Rd., Padeh, Taoyuan, Taiwan 334, R.O.C.
TEL: +886-3-3675151 FAX: +886-3-377-3858

Doc.No:	SPEC_CLAA048LA0BCW_V0.2_090428	Issue Date:	2009/03/23
---------	--------------------------------	-------------	------------

REVISION STATUS

Revision Notice	Description	Page	Rev. Date
0.0	First revision (Tentative)	--	2009.02.10
0.1	Revise Number of color of General specifications	P.4	2009.02.29
0.2	Revised Adjust control pin (ADJ) of Interface Connection	P.11	2009.03.23

1. OVERVIEW	4
2. ABSOLUTE MAXIMUM RATINGS	5
3. ELECTRICAL CHARACTERISTICS	6
3.1. TFT LCD (Power Supply Voltage)	6
3.2. TFT-LCD (Consumption Current)	6
3.3. Power on/off sequence.....	7
4. INPUT SIGNAL TIMING	8
4.1 Signal Timing Specification.....	8
4.2 Signal Timing Waveforms	8
4.3 Color data definition	10
5. INTERFACE CONNECTION	11
6. MECHANICAL SPECIFICATION	13
7. OPTICAL SPECIFICATION	14
8. RELIABILITY TEST	16
8.1 Temperature and Humidity	16
8.2 Shock & Vibration	16
8.3 ESD.....	16
8.4 Judgment standard.....	16

1. OVERVIEW

CPT CLAA048LA0BCW is 4.8" color TFT-LCD (Thin Film Transistor Liquid Crystal Display) module.

The 4.8" screen produces a high resolution image that is composed of 384000 (800×480) pixel elements in a Side-stripe arrangement.

General specifications are summarized in the following table:

ITEM	SPECIFICATION
Panel Size	4.8" inch
Display Area (mm)	103.8(W)X62.28(H)
Number of Pixels (dot)	800(H) x 480(V) x 3(RGB)
Pixel Pitch (mm)	0.12975(H)*0.12975(V)
Color Pixel Arrangement	RGB vertical strip
Display Mode	Normally white TN
Number of color	16M colors
Luminance (cd/m ²)	350nit(typ)
Contrast Ratio	400:1(typ)
Optimum Viewing Angle	6' o'clock
Electrical Interface	TTL(8 bit input)
Power Consumption(W)	1.4W(with B/L)
Surface Treatment	Anti-Glare
Outline Dimension (mm)	114.65(H)*74.7(V)*4.72(D) w Component
Weight (g)	55 g(Typ)

Note 1. Outline Dimension define without FPC

The LCD Products listed on this document are not suitable for use of aerospace equipments, submarine cables, nuclear reactor control systems and life support systems. If customers intend to use these LCD products for above applications or not listed in "Standard" as follows, please contact our sales people in advance.

2. ABSOLUTE MAXIMUM RATINGS

ITEM	SYMBOL	MIN.	MAX.	UNIT	NOTE
Power Input Voltage	VCC	-0.3	4.6	Vdc	At 25±5°C
LED Driving Circuit Power Supply	VLED	-0.3	7.0	Vdc	At 25±5°C
Operating Temperature	TOP	-20	70	°C	Note1
Storage Temperature	TST	-30	80	°C	Note1
Operation Ambient Humidity	HOP	10	90	%RH	Note1
Storage Humidity	HST	10	90	%RH	Note1

Note : 1. Temperature and relative humidity range are shown in the figure below.
Wet bulb temperature should be 39°C Max, and no condensation of water.

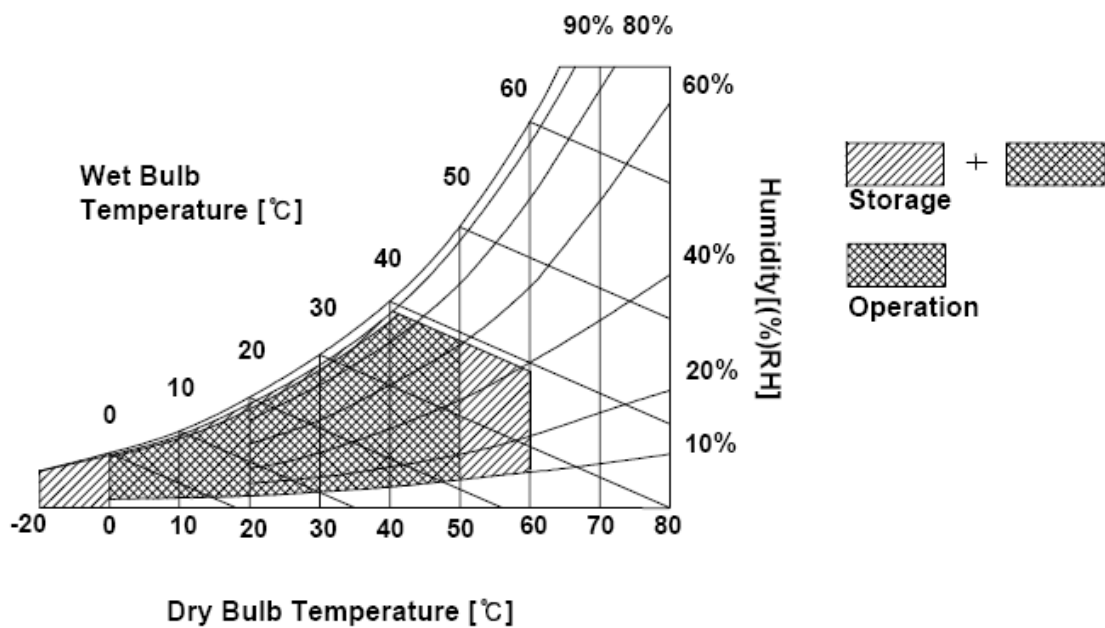

3. ELECTRICAL CHARACTERISTICS

3.1. TFT LCD (Power Supply Voltage)

Ta = 25°C

PARAMETERS	SYMBOL	MIN.	TYP.	MAX.	UNIT	NOTE
Power Supply Input Voltage	VCC	3.0	3.3	3.6	V	
Input Signal Voltage	VIH	0.8*VCC	---	VCC	V	
	VIL	GND	---	0.2*VCC	V	
LED Driving Circuit Power Supply	VLED	3	5	5.5	V	
ADJ Input Voltage	VADJH	3.0	---	3.3	V	
	VADJL	GND	---	0.3	V	

3.2. TFT-LCD (Consumption Current)

Ta = 25°C

PARAMETERS	SYMBOL	MIN.	TYP.	MAX.	UNIT	NOTE
LCD Power Current	ICC	---	125	135	mA	Note1
LED Power Current	ILED	170	190	320	mA	Note2

Note 1 :

Typ. specification : Gray-256 test Pattern.

Max. specification : Black test Pattern.

The specified current and power consumption are under the VCC = 3.3V, fv = 60Hz condition. Where as Mosaic pattern is displayed and fv is the frame frequency.



(a)Gray-256 Pattern

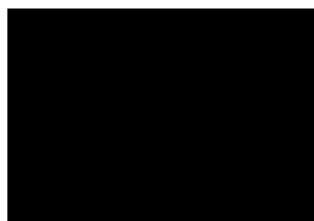

(b)Black Pattern

Note 2 :

Min. specification : VLED=5.5V.

Typ. specification : VLED=5V.

Max. specification : VLED=3V.

3.3. Power on/off sequence

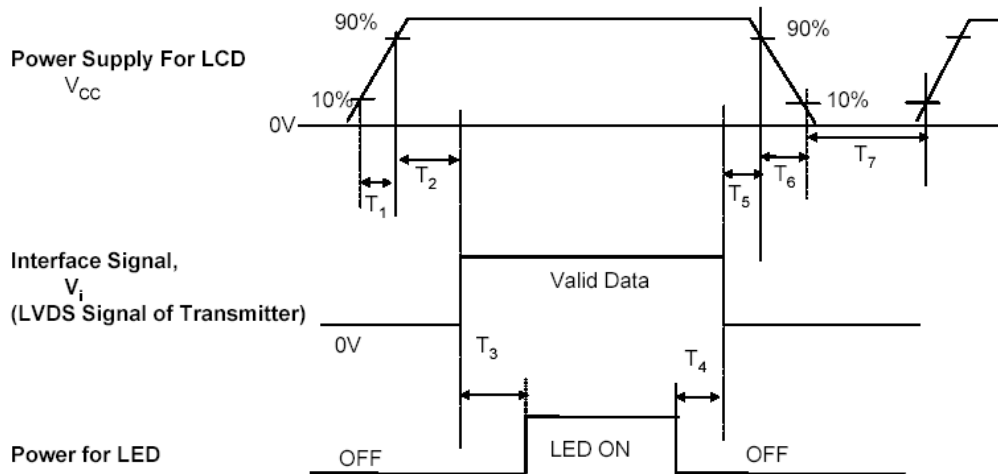

PARAMETERS	VALUE			UNITS
	MIN.	TYP.	MAX.	
T1	0.5	---	10	ms
T2	0	---	50	ms
T3	200	---	---	ms
T4	200	---	---	ms
T5	0	---	50	ms
T6	0	---	10	ms
T7	200	---	---	ms

4. INPUT SIGNAL TIMING

4.1 Signal Timing Specification

This is the signal timing required at the input of the user connector. All of the interface signal timing should be satisfied with the following specifications for its proper operation.

ITEM		SYMBOL	MIN.	TYP.	MAX.	UNIT
DCLK	Dot Clock	1/tclk	25	27	32	MHz
	Dot Clock Period	Tcp	31.25	---	---	ns
	High Level Width	Tch	0.3	---	---	Tcp
	Low Level Width	Tcl	0.3	---	---	
DATA	Setup Time	Tids	5	---	---	ns
	Hold Time	Tidh	10	---	---	
SYNC	HSYNC Setup Time	Thss	5	---	---	ns
	HSYNC Hold Time	Thsh	10	---	---	
	HSYNC Period	Ths	870	900	---	
	HSYNC Low Pulse Width	Thp	1	1	---	t _{CLK}
	HSYNC Display Start	The	---	50	---	
	Horizontal Active	Thd	800			
	VSYNC Setup Time	Tvss	5	---	---	ns
	VSYNC Hold Time	Tvsh	10	---	---	
	VSYNC Period	Tvs	490	500	---	Ths
	VSYNC Low Pulse Width	Tvp	1	1	---	
	VSYNC Display Start	Tve	---	6	---	
	Vertical Active	Tvd	480			
	Vertical Frequency	fV	---	60	---	

【Note1】 This module is operated by SYNC only mode.

4.2 Signal Timing Waveforms

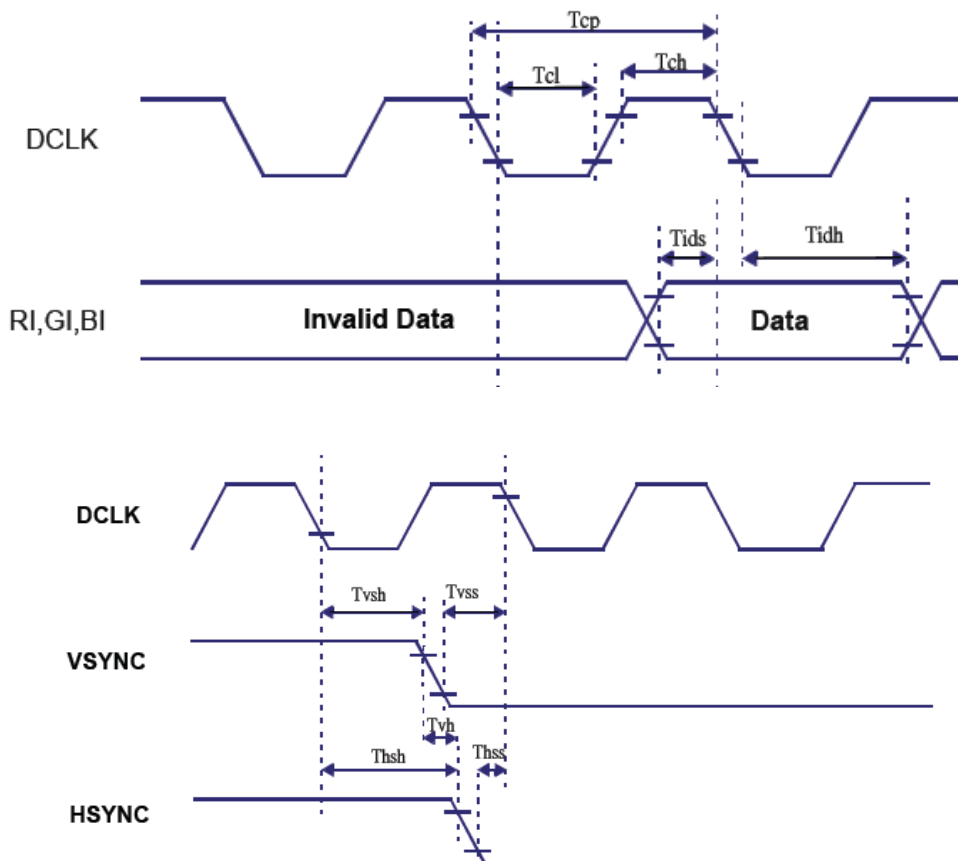

Vertical Timing Diagram

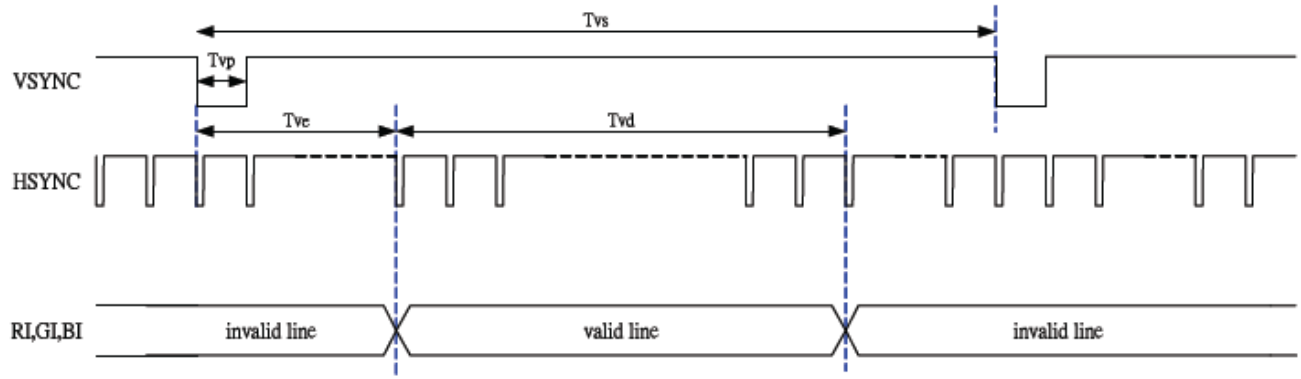

Horizontal Timing Diagram

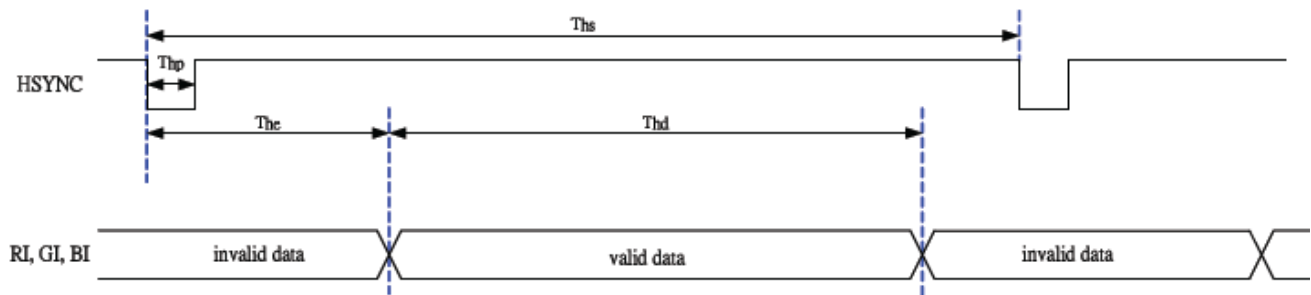

4.3 Color data definition

COLOR	INPUT DATA	R DATA								G DATA								B DATA							
		R7	R6	R5	R4	R3	R2	R1	R0	G7	G6	G5	G4	G3	G2	G1	G0	B7	B6	B5	B4	B3	B2	B1	B0
		MSB				LSB				MSB				LSB				MSB				LSB			
BASIC COLOR	BLACK	0	0	0	0	0	0	0	0	0	0	0	0	0	0	0	0	0	0	0	0	0	0	0	0
	RED(255)	1	1	1	1	1	1	1	1	0	0	0	0	0	0	0	0	0	0	0	0	0	0	0	
	GREEN(255)	0	0	0	0	0	0	0	0	1	1	1	1	1	1	1	0	0	0	0	0	0	0	0	
	BLUE(255)	0	0	0	0	0	0	0	0	0	0	0	0	0	0	0	1	1	1	1	1	1	1	1	
	CYAN	0	0	0	0	0	0	0	0	1	1	1	1	1	1	1	1	1	1	1	1	1	1	1	
	MAGENTA	1	1	1	1	1	1	1	1	0	0	0	0	0	0	0	1	1	1	1	1	1	1	1	
	YELLOW	1	1	1	1	1	1	1	1	1	1	1	1	1	1	1	0	0	0	0	0	0	0	0	
	WHITE	1	1	1	1	1	1	1	1	1	1	1	1	1	1	1	1	1	1	1	1	1	1	1	
RED	RED(0)	0	0	0	0	0	0	0	0	0	0	0	0	0	0	0	0	0	0	0	0	0	0	0	
	RED(1)	0	0	0	0	0	0	0	1	0	0	0	0	0	0	0	0	0	0	0	0	0	0	0	
	RED(2)	0	0	0	0	0	0	1	0	0	0	0	0	0	0	0	0	0	0	0	0	0	0	0	
	RED(254)	1	1	1	1	1	1	1	0	0	0	0	0	0	0	0	0	0	0	0	0	0	0	0	
	RED(255)	1	1	1	1	1	1	1	1	0	0	0	0	0	0	0	0	0	0	0	0	0	0	0	
GREEN	GREEN(0)	0	0	0	0	0	0	0	0	0	0	0	0	0	0	0	0	0	0	0	0	0	0	0	
	GREEN(1)	0	0	0	0	0	0	0	0	0	0	0	0	0	0	1	0	0	0	0	0	0	0	0	
	GREEN(2)	0	0	0	0	0	0	0	0	0	0	0	0	0	0	1	0	0	0	0	0	0	0	0	
	GREEN(254)	0	0	0	0	0	0	0	0	1	1	1	1	1	1	0	0	0	0	0	0	0	0	0	
	GREEN(255)	0	0	0	0	0	0	0	0	1	1	1	1	1	1	1	0	0	0	0	0	0	0	0	
BLUE	BLUE(0)	0	0	0	0	0	0	0	0	0	0	0	0	0	0	0	0	0	0	0	0	0	0	0	
	BLUE(1)	0	0	0	0	0	0	0	0	0	0	0	0	0	0	0	0	0	0	0	0	0	0	1	
	BLUE(2)	0	0	0	0	0	0	0	0	0	0	0	0	0	0	0	0	0	0	0	0	0	1	0	
	BLUE(254)	0	0	0	0	0	0	0	0	0	0	0	0	0	0	0	1	1	1	1	1	1	1	0	
	BLUE(255)	0	0	0	0	0	0	0	0	0	0	0	0	0	0	0	1	1	1	1	1	1	1	1	

Note 1 : Definition of gray scale:

Color (n): n means level of gray scale. Larger n means brighter level.

Note 2 : Data: 1= High, 0 = Low

5. INTERFACE CONNECTION

NO	SYMBOL	FUNCTION	REMARK
1	GND	Ground	
2	VCC	Power Supply	3.3V
3	VCC	Power Supply	
4	GND	Ground	
5	DCLK	Dot Clock	
6	GND	Ground	
7	B0	Blue Data 0	
8	B1	Blue Data 1	
9	B2	Blue Data 2	
10	B3	Blue Data 3	
11	B4	Blue Data 4	
12	B5	Blue Data 5	
13	B6	Blue Data 6	
14	B7	Blue Data 7	
15	G0	Green Data 0	
16	G1	Green Data 1	
17	G2	Green Data 2	
18	G3	Green Data 3	
19	G4	Green Data 4	
20	G5	Green Data 5	
21	G6	Green Data 6	
22	G7	Green Data 7	
23	R0	Red Data 0	
24	R1	Red Data 1	
25	R2	Red Data 2	
26	R3	Red Data 3	
27	R4	Red Data 4	
28	R5	Red Data 5	
29	R6	Red Data 6	
30	R7	Red Data 7	
31	GND	Ground	
32	NC	No Connect	
33	NC	No Connect	
34	NC	No Connect	
35	HSYNC	Horizontal SYNC	
36	VSYNC	Vertical SYNC	
37	NC	No Connect	
38	NC	No Connect	
39	NC	No Connect	
40	GND	Ground	
41	XR	TP Right electrode	
42	YU	TP Top electrode	
43	XL	TP Left electrode	
44	YD	TP Bottom electrode	
45	GND	Ground	
46	VLED	LED Power	5V/200mA
47	GND	Ground	
48	ADJ	Brightness control for LED B/L	
49	GND	Ground	
50	GND	Ground	

Note 1 : To reserve NC pin, don't make it connect with GND or any other signal.

Note 2 : Adjust control pin (ADJ) controls brightness. The bigger pulse duty, will be the brighter luminance.

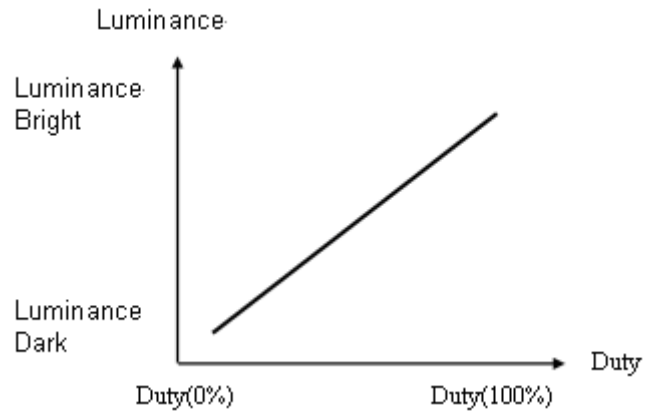

Note 3 : ADJ signal=0~3.3V, operation frequency: 25KHZ±5KHZ

$$F=25\text{KHz} \pm 5\text{KHz} \cdot T=0.05\text{ms}$$

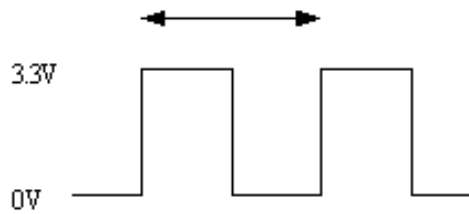

Note 4 : The ADJ should pull-high if not adjust brightness, this pin can't floating.

6. MECHANICAL SPECIFICATION

6.1 Front Side

[Unit : mm]

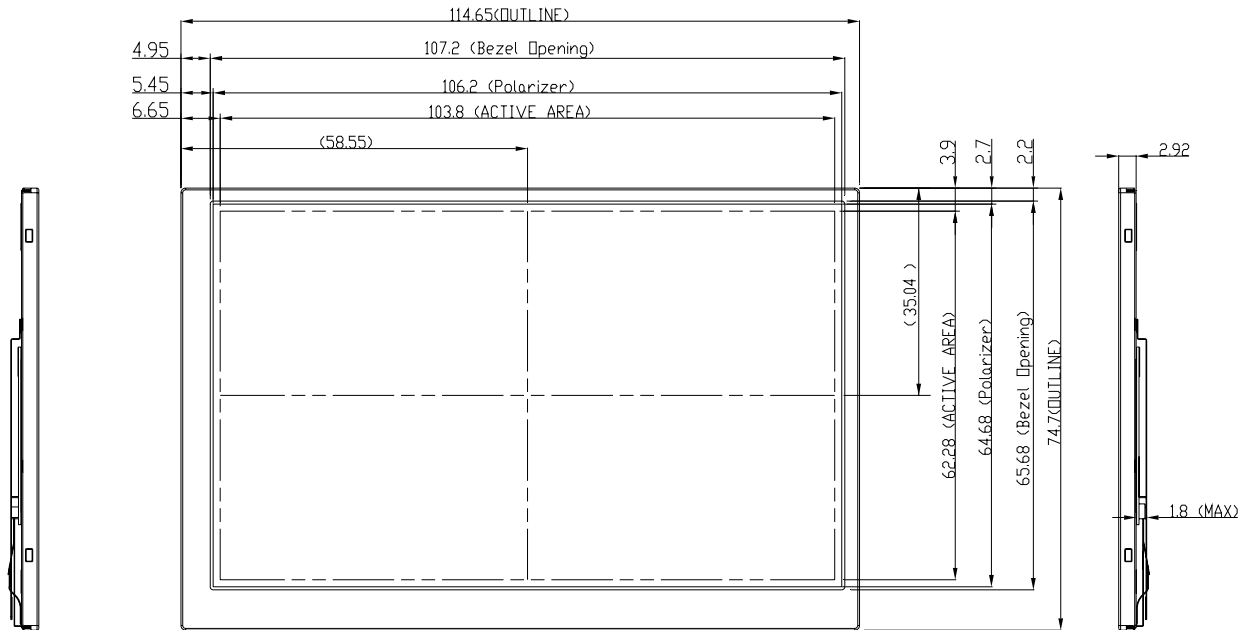

Note : Unit:[mm], General tolerance : $\pm 0.3\text{mm}$

6.2 Rear Side

[Unit : mm]

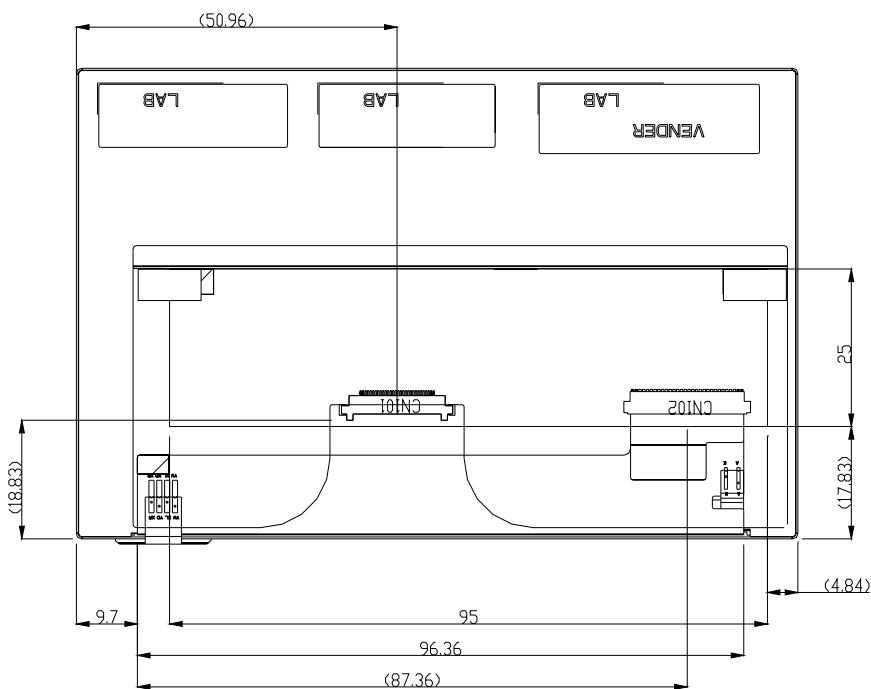

Note : Unit:[mm], General tolerance : $\pm 0.3\text{mm}$

7. OPTICAL SPECIFICATION

ITEM		SYMBOL	CONDITION	MIN.	TYP.	MAX.	UNIT	NOTE
Contrast Ratio		CR	$\theta = \psi = 0^\circ$ Point-5		400	--		*1)*2)*3)
Luminance		L	$\theta = \psi = 0^\circ$ Point-5	280	350	--	cd/m ²	*1)*2)
Luminance Uniformity		ΔL	$\theta = \psi = 0^\circ$	70	75	--	%	*1)*2)*4)
Response Time		Tr+Tf	$\theta = \psi = 0^\circ$	--	20	--	ms	*1)*2)*5)
View angle	Horizontal	ϕ	$CR \geq 10$ Point-5		140	--	°	*1)*2)*6)
	Vertical	θ			110	--	°	
Color Coordinate	W	x	$\theta = \psi = 0^\circ$ Point-5	0.273	0.313	0.353		*1)*2)
		y		0.289	0.329	0.369		
	R	x		TBD	TBD	TBD		
		y		TBD	TBD	TBD		
	G	x		TBD	TBD	TBD		
		y		TBD	TBD	TBD		
	B	x		TBD	TBD	TBD		
		y		TBD	TBD	TBD		

【Note】

*1) Ambient condition : $25^\circ\text{C} \pm 2^\circ\text{C}$, $60 \pm 10\% \text{RH}$, under 10 Lux in the darkroom 。
Lighting the LCM and measuring after 10 minutes.

*2) Measure device : BM-5A (TOPCON) , viewing cone= 1° , $I_L=40.0\text{mA}$ 。

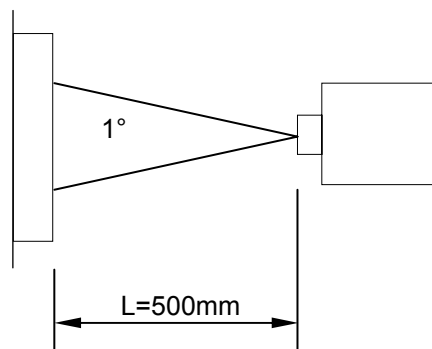

Fig.7-1 viewing cone= 1°

*3) Definition of Contrast Ratio :

$$CR = \text{White Luminance (ON)} / \text{Black Luminance (OFF)}$$

*4) Definition of Luminance Uniformity : $\Delta L = L(\text{MIN}) / L(\text{MAX}) \times 100\%$

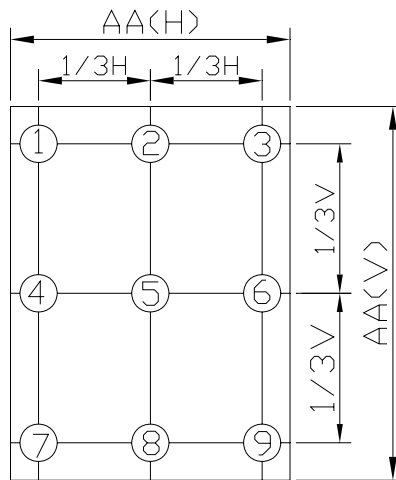

Fig.7-2 Measuring point

*5) Definition of response time : The response time is defined as the time interval between the 10% and 90% amplitudes.

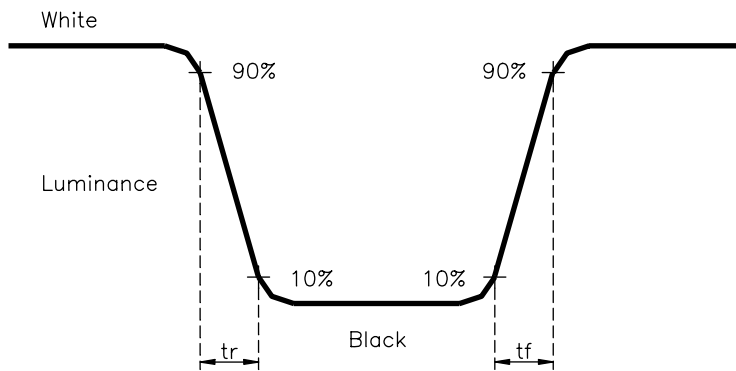

Fig.7-3 Definition of Response Time (White - Black)

*6) Definition of view angle(θ , ψ) :

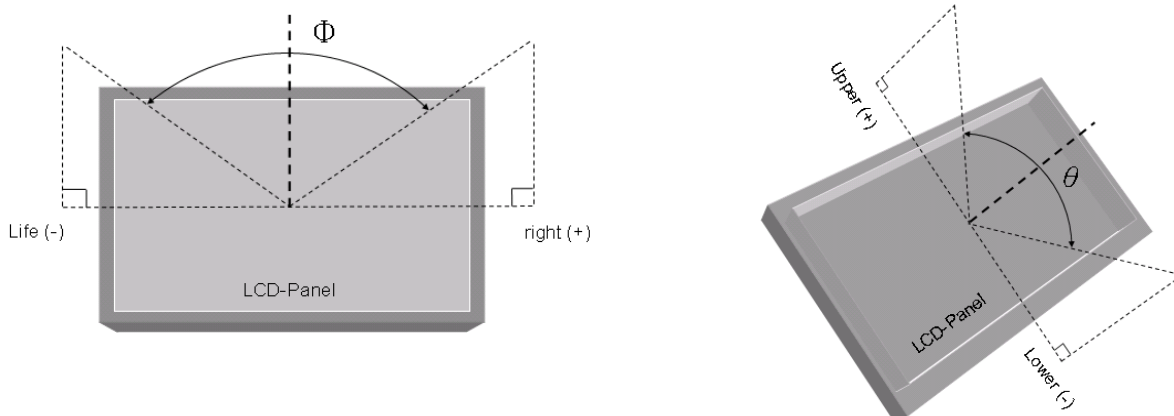

Fig.7-4 Definition of Viewing Angle

8. RELIABILITY TEST

8.1 Temperature and Humidity

TEST ITEMS	CONDITIONS
HIGH TEMPERATURE OPERATION	70° C ; 240Hrs
HIGH TEMPERATURE STORAGE	80° C ; 240Hrs
HIGH TEMPERATURE AND HIGH HUMIDITY OPERATION	60° C ; 90% RH ; 240Hrs
LOW TEMPERATURE OPERATION	-20° C ; 240Hrs
LOW TEMPERATURE STORAGE	-30° C ; 240Hrs
THERMAL SHOCK (No operation)	-30° C (0.5Hr)~80° C (0.5Hr) , 200 Cycles

8.2 Shock & Vibration

TEST ITEMS	CONDITIONS
SHOCK (Non operation)	<ul style="list-style-type: none"> ● Shock level: 980m/s²(equal to 100G). ● Waveform: half sinusoidal wave,6ms. ● Number of shocks: one shock input in each direction of three mutually perpendicular axes(±X, ±Y, ±Z)for a total of 6 shock inputs.
VIBRATION (Non operation)	<ul style="list-style-type: none"> ● Frequency range:8~33.3Hz ● Stroke:1.3 mm ● Vibration:sinusoidal wave, perpendicular axis Each direction on X, Z axes: 2hrs, Y axes: 4hrs. ● Sweep:2.9G,33.3 Hz ~ 400 Hz ● Cycle:15 min

8.3 ESD

TEST ITEM	CONDITIONS	Note
ESD (Non operation)	150 pF · 330Ω · ±8KV,±15KV	Air / Contact test
	200 pF · 0Ω · ±200V	Contact test

8.4 Judgment standard

The judgment of the above test should be made as follow:

Pass : Normal display image with no obvious non-uniformity and no line defect.

Partial transformation of the module parts should be ignored.

Fail : No display i mage, obvious non-uniformity, or line defects.