



# Chunghwa Picture Tubes, Ltd.

## Product Specification

To :

Date : 20060825

**TFT LCD**

***CLAA057VA01***

ACCEPTED BY :

TENTATIVE

APPROVED BY	CHECKED BY	PREPARED BY
張聖暉	李家銘	謝明聰

Prepared by :

Small &Medium Product Planning Management Department

Small &Medium Product General Division

**CHUNGHWA PICTUER TUBES, LTD.**

Doc.No:

Issue Date:

2006/07/21



## CONTENTS

<b>1. OVERVIEW</b> .....	<b>4</b>
<b>2. ABSOLUTE MAXIMUM RATINGS</b> .....	<b>5</b>
<b>3. ELECTRICAL CHARACTERISTICS</b> .....	<b>7</b>
3.1TFT LCD .....	7
3.2TFT-LCD current consumption.....	8
3.3 Power 、 Signal sequence.....	8
<b>4. INTERFACE CONNECTION</b> .....	<b>9</b>
<b>5. INPUT SIGNAL(DE ONLY MODE)</b> .....	<b>11</b>
5.1 Timing Specification .....	11
5.2 Timing sequence(Timing chart).....	12
5.3 Color Data Assignment.....	13
<b>6. BLOCK DIAGRAM</b> .....	<b>14</b>
<b>7. MECHANICAL DIMENSION</b> .....	<b>15</b>
7.1 Front Side .....	15
7.2 Rear Side .....	16
<b>8. OPTICAL CHARACTERISTICS</b> .....	<b>17</b>
<b>9. RELIABILITY TEST</b> .....	<b>20</b>
9-1. Temperature and humidity.....	20
9-2. Shock and Vibration.....	20
9-3. Judgment standard .....	20

## 1. OVERVIEW

CLAA057VAO1 is 5.7" color TFT-LCD(Thin Film Transistor Liquid Crystal Display)module composed of LCD panel,driver ICs,control circuit,and LED backlight.

The 5.7"screen produces a high resolution image that is composed of 640×480 pixel elements in a stripe arrangement.Display 262K colors by 6 Bit R.G.B signal input.

General specifications are summarized in the following table:

ITEM	SPECIFICATION
Panel Size	5.7 inch(panel diagonal)
Display Area (mm)	116.16(W)×87.12(H)
Number of Pixels	640×3(H)×480(V)
Pixel Pitch (mm)	0.1815(H)×0.1815(V)
Color Pixel Arrangement	RGB vertical stripe
Display Mode	Normally white
Number of colors	262,144
Viewing Direction	6 o'clock
Response Time (Tr+Tf)	30ms
Brightness(cd/m <sup>2</sup> )	220nit(typ)
NTSC ratio	50%
Viewing Angle(BL on,CR≥10)	140 degree(H) , 100degree(V)
Electrical Interface(data)	TTL
Power consumption(W)	TBD
Outline Dimension(in mm)	127(W)×100(H)×7(D)
Weight(g)	TBD
BL unit	LED
Surface Treatment	Anti-Glare , Hardness:3H

## 2. ABSOLUTE MAXIMUM RATINGS

Item	Symbol	Min.	Max.	Unit	Note
Power Supply Voltage	Vcc	-0.5	5.0	V	
Signal Input Voltage	DCLK,DE,R0,G0 ,B0~R5,G5,B5	-0.5	Vcc + 0.5	V	
Static Electricity	VESDc	-200	+200	V	*2)
	VESDm	-15K	+15K	V	
ICC Rush Current	IRUSH	-	1	A	*3)
Operation Temperature	T <sub>op</sub>	-30	85	°C	*1)
Storage Temperature	T <sub>stg</sub>	-40	95	°C	*1)
Forward Current (per LED)	I <sub>f</sub>	---	30	mA	
Reverse Voltage (per LED)	VR	---	5	V	
Pulse forward current (per LED)	I <sub>fp</sub>	---	100	mA	*4)

Remarks :

- \*1) If users use the product out off the environment operation range ( temperature and humidity ) ,it will concern for visual quality.
- \*2) Test Condition: IEC 61000-4-2 ,  
VESDc : Contact discharge to input connector  
VESDm : Contact discharge to module
- \*3) The input pulse-current measurement system as below :

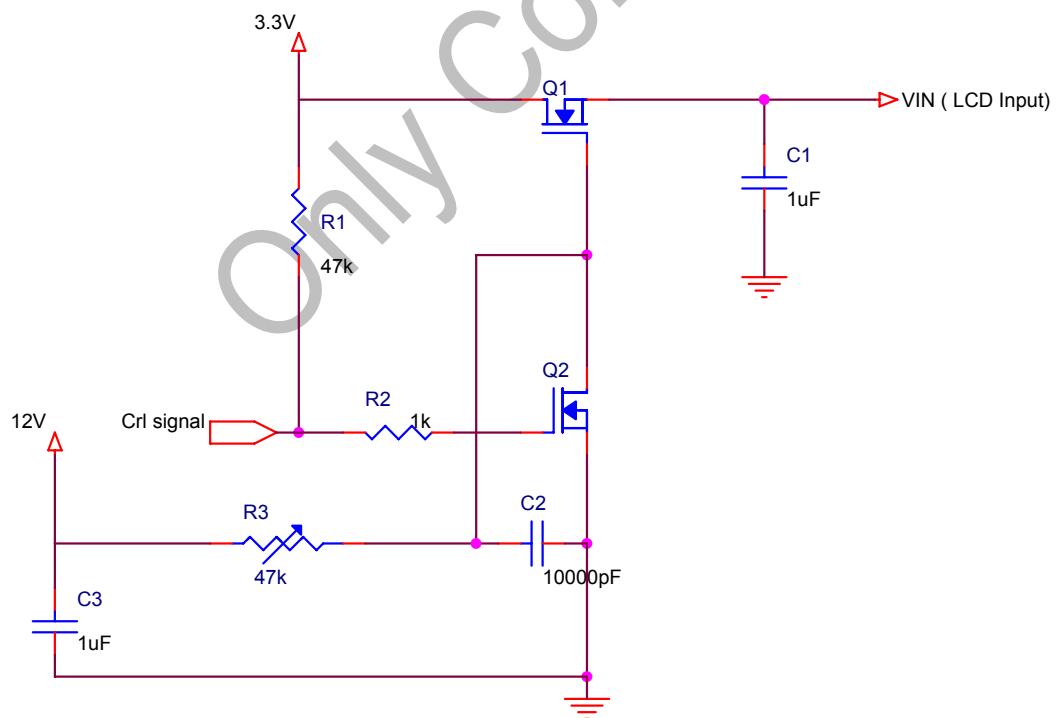

Control signal: High(+3.3V)→Low(GND)

Supply Voltage of rising time should be from R3 and C2 tune to 550 us.

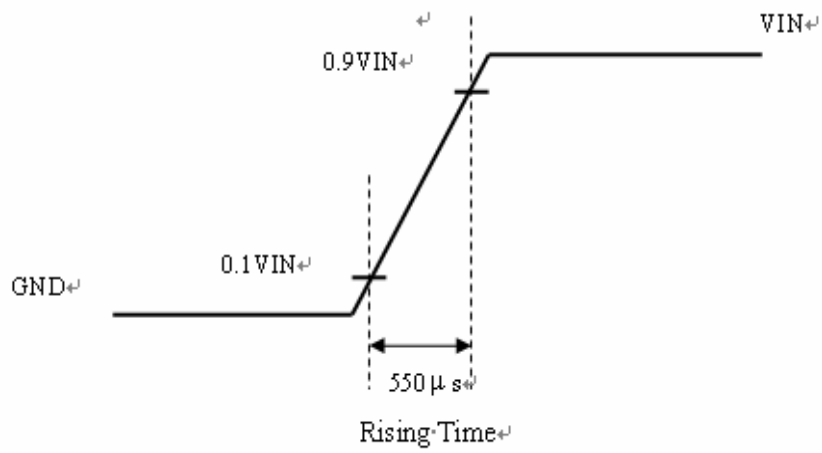

\*4) Ifp Conditions : Pulse Width=0.1msec and Duty=1/10 °

Only Confidential

### 3. ELECTRICAL CHARACTERISTICS

#### 3.1 TFT LCD

Ta=25°C

Item	Symbol	Min.	Typ	Max.	Unit	Note
Power Supply Voltage For LCD	VCC	3.0	3.3	3.6	V	*1)
Power Supply Voltage For LED	VDD	2.7	3.3	5	V	
Logic Input Voltage	VIH	VCC*0.7	--	VCC	V	
	VIL	0	--	VCC*0.3	V	

Remarks :

\*1) VCC -dip condition:

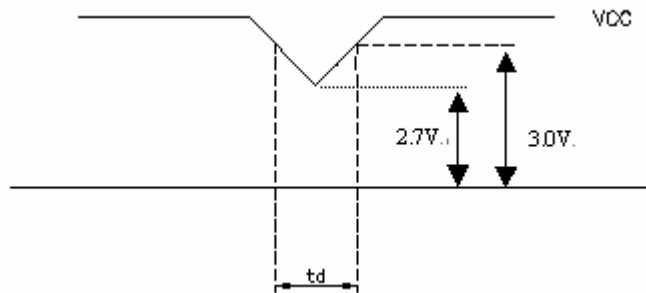
When  $2.7\text{ V} \leq \text{VCC} < 3.0\text{ V}$ ,  $t_d \leq 10\text{ ms}$ . $\text{VCC} > 3.0\text{ V}$ , VCC-dip condition should be same as VCC-turn-on condition.

3.2TFT-LCD current consumption

Item	Symbol	Min.	Typ	Max.	Unit	Note
LCD power current	ICC	--	TBD	TBD	mA	*1)
LED power current	IDD		TBD	TBD	mA	*2)

\*1) Typical: Under 64 gray pattern  
 Maximum: Under black pattern

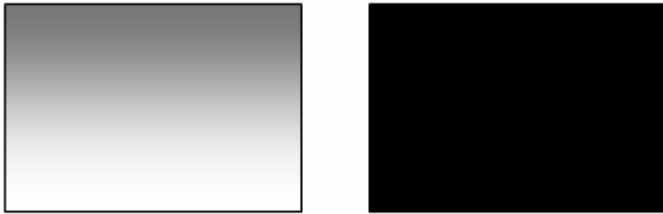

(a) 64 Gray Pattern (b) Black Pattern

\*2) Typical: When VDD is 3.3V  
 Maximum: When VDD is 2.7V

3.3 Power 、 Signal sequence

- $t1 \leq 10ms$        $1 \text{ sec} \leq t5$
- $50ms \leq t2$        $200ms \leq t6$
- $0 < t3 \leq 50ms$        $200ms \leq t7$
- $0 < t4 \leq 10ms$

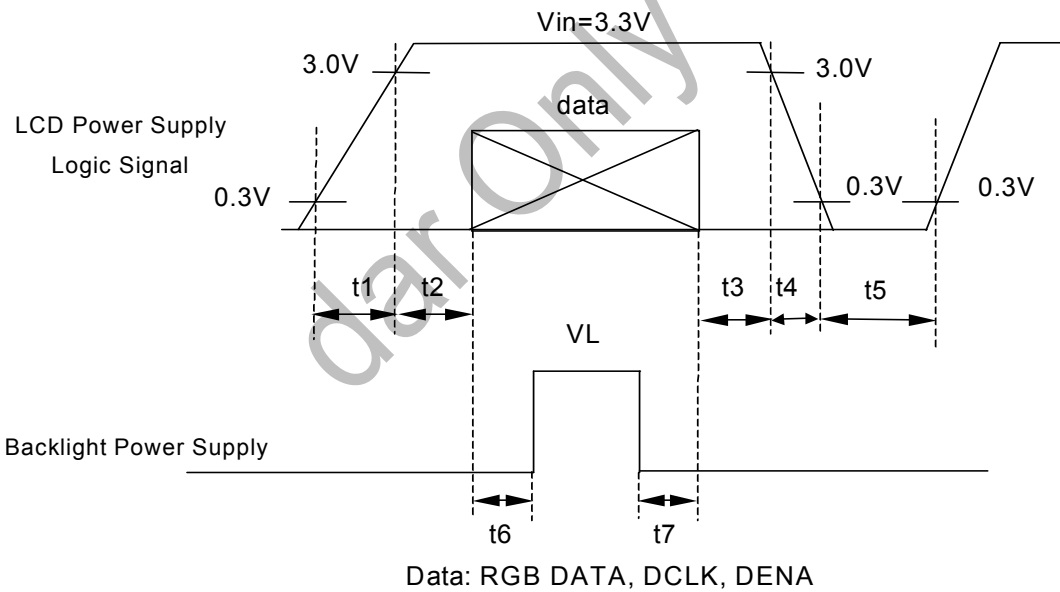



## 4. INTERFACE CONNECTION

(Connector type:40pin/0.5mm pitch/Bottom contact)-089N40-000R00-G2

Pin NO.	SYMBOL	DESCRIPTION
1	U/D	Up or Down Display Control
2	DMS	Selection DE or SYNC
3	Hsync	Horizontal SYNC.
4	Vcc	Power Supply for Digital Circuit
5	Vcc	Power Supply for Digital Circuit
6	Vcc	Power Supply for Digital Circuit
7	Vcc	Power Supply for Digital Circuit
8	Vsync	Vertical SYNC.
9	DE	Data Enable
10	V <sub>ss</sub>	Power Ground
11	V <sub>ss</sub>	Power Ground
12	ADJ	Adjust for LED brightness
13	B5	Blue Data 5 (MSB)
14	B4	Blue Data 4
15	B3	Blue Data 3
16	V <sub>ss</sub>	Power Ground
17	B2	Blue Data 2
18	B1	Blue Data 1
19	B0	Blue Data 0 (LSB)
20	V <sub>ss</sub>	Power Ground
21	G5	Green Data 5 (MSB)
22	G4	Green Data 4
23	G3	Green Data 3
24	V <sub>ss</sub>	Power Ground
25	G2	Green Data 2
26	G1	Green Data 1
27	G0	Green Data 0 (LSB)
28	V <sub>ss</sub>	Power Ground
29	R5	Red Data 5 (MSB)
30	R4	Red Data 4
31	R3	Red Data 3
32	V <sub>ss</sub>	Power Ground
33	R2	Red Data 2
34	R1	Red Data 1
35	R0	Red Data 0 (LSB)
36	V <sub>ss</sub>	Power Ground
37	V <sub>ss</sub>	Power Ground
38	DCLK	Clock Signals
39	V <sub>ss</sub>	Power Ground
40	L/R	Left or Right Display Control

Remarks :

1).ADJ adjust brightness to control Pin · Pulse duty the more small the more bright



2) ADJ signal =0~3.3V , operation frequency:20KHZ

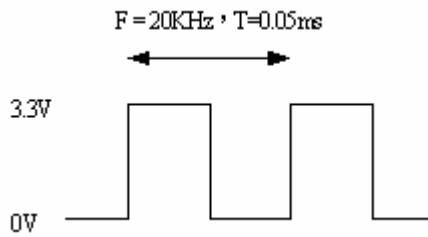

3) GND Pin must ground contact , can not be floating.

4) U/D and L/R are controlled function

L/R	U/D	Function
1	0	Normally display
0	0	Left and Right opposite
1	1	Up and Down opposite
0	1	Left and Right opposite , Up and Down opposite

5) DMS ( Selection DE / SYNC mode )

DMS	Function
1	DE Mode
0	SYNC Mode

Only Confidential

## 5. INPUT SIGNAL(DE ONLY MODE)

### 5.1 Timing Specification

ITEM		SYMBOL	MIN.	TYP.	MAX.	UNIT
DCLK	Period	$t_{CLK}$	16.67			ns
	Dot Clock	$f_{CLK}$	5	-	40	MHz
	Low Level Width	$t_{WCL}$	0.3	-	-	ns
	High Level Width	$t_{WCH}$	0.3	-	-	
DE	Setup Time	$t_{DES}$	5	-	-	ns
	Hold time	$t_{DEH}$	10	-	-	
	Horizontal Period	$t_{HP}$	750	800	900	$t_{CLK}$
	Horizontal Valid	$t_{HV}$	640			
	Horizontal Blank	$t_{HBK}$	110	160	260	
	Vertical Period	$t_{VP}$	515	525	560	$t_{HP}$
	Vertical Valid	$t_{VV}$	480			
	Vertical Blank	$t_{VBK}$	35	45	80	
	Vertical Frequency	$f_V$	55	60	65	
DATA	Setup Time	$t_{DS}$	4	-	-	ns
	Hold Time	$t_{DH}$	8	-	-	

Remarks :

- \*1) High level of logic signal is 80% ◦ Low level of logic signal is 20% ◦
- \*2) This module is operated by DE only mode

5.2 Timing sequence(Timing chart)

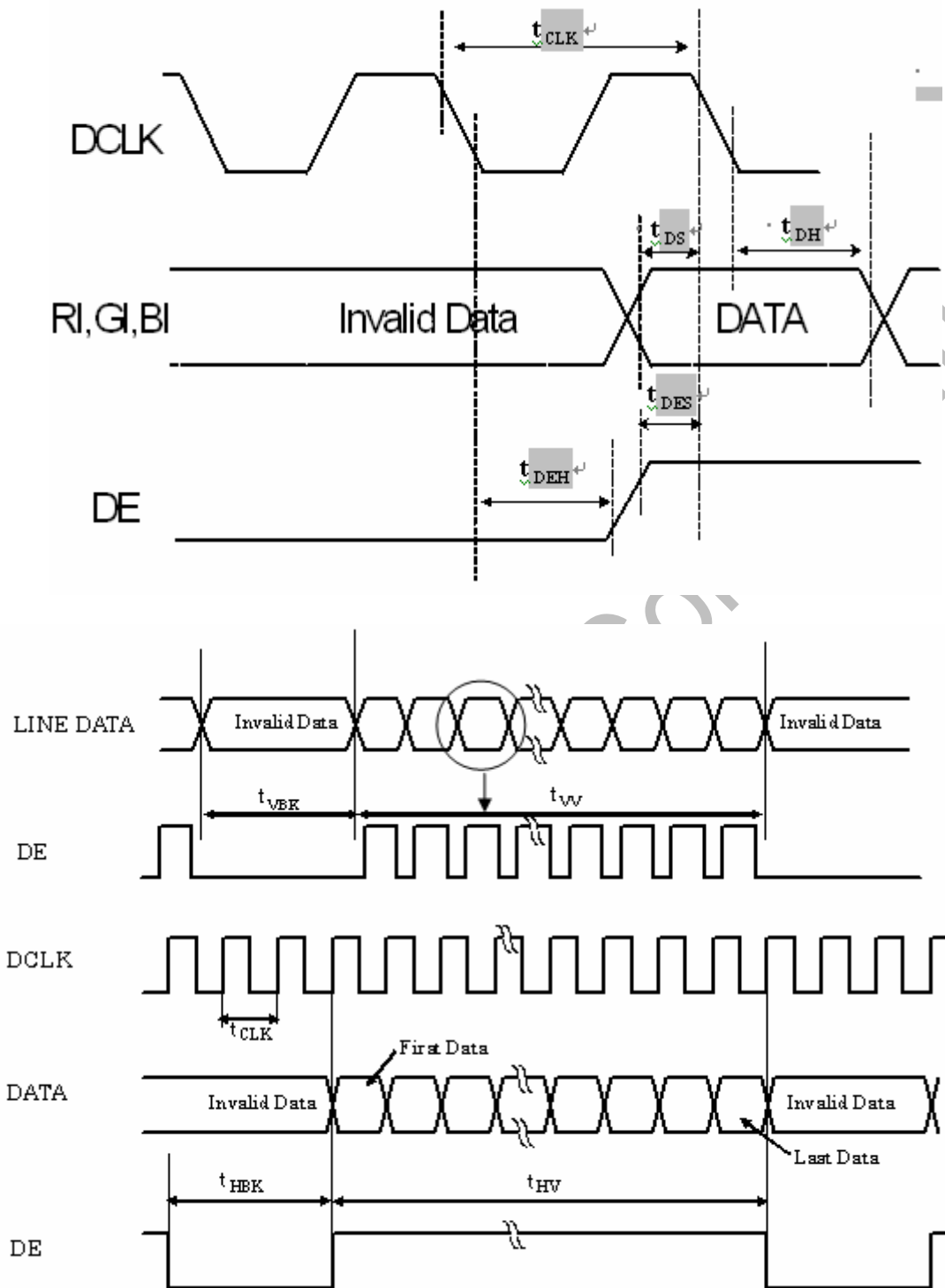

5.3 Color Data Assignment

COLOR	INPUT	R DATA						G DATA						B DATA					
		R5	R4	R3	R2	R1	R0	G5	G4	G3	G2	G1	G0	B5	B4	B3	B2	B1	B0
	DATA	MSB					LSB	MSB					LSB	MSB					LSB
	BLACK	0	0	0	0	0	0	0	0	0	0	0	0	0	0	0	0	0	0
	RED(63)	1	1	1	1	1	1	0	0	0	0	0	0	0	0	0	0	0	0
BASIC	GREEN(63)	0	0	0	0	0	0	1	1	1	1	1	1	0	0	0	0	0	0
COLOR	BLUE(63)	0	0	0	0	0	0	0	0	0	0	0	0	1	1	1	1	1	1
	CYAN	0	0	0	0	0	0	1	1	1	1	1	1	1	1	1	1	1	1
	MAGENTA	1	1	1	1	1	1	0	0	0	0	0	0	1	1	1	1	1	1
	YELLOW	1	1	1	1	1	1	1	1	1	1	1	1	0	0	0	0	0	0
	WHITE	1	1	1	1	1	1	1	1	1	1	1	1	1	1	1	1	1	1
	RED(0)	0	0	0	0	0	0	0	0	0	0	0	0	0	0	0	0	0	0
	RED(1)	0	0	0	0	0	1	0	0	0	0	0	0	0	0	0	0	0	0
	RED(2)	0	0	0	0	1	0	0	0	0	0	0	0	0	0	0	0	0	0
RED																			
	RED(62)	1	1	1	1	1	0	0	0	0	0	0	0	0	0	0	0	0	0
	RED(63)	1	1	1	1	1	1	0	0	0	0	0	0	0	0	0	0	0	0
	GREEN(0)	0	0	0	0	0	0	0	0	0	0	0	0	0	0	0	0	0	0
	GREEN(1)	0	0	0	0	0	0	0	0	0	0	1	0	0	0	0	0	0	0
	GREEN(2)	0	0	0	0	0	0	0	0	0	0	1	0	0	0	0	0	0	0
GREEN																			
	GREEN(62)	0	0	0	0	0	0	1	1	1	1	1	0	0	0	0	0	0	0
	GREEN(63)	0	0	0	0	0	0	1	1	1	1	1	1	0	0	0	0	0	0
	BLUE(0)	0	0	0	0	0	0	0	0	0	0	0	0	0	0	0	0	0	0
	BLUE(1)	0	0	0	0	0	0	0	0	0	0	0	0	0	0	0	0	0	1
	BLUE(2)	0	0	0	0	0	0	0	0	0	0	0	0	0	0	0	0	1	0
BLUE																			
	BLUE(62)	0	0	0	0	0	0	0	0	0	0	0	0	1	1	1	1	1	0
	BLUE(63)	0	0	0	0	0	0	0	0	0	0	0	0	1	1	1	1	1	1

Remarks :

(1) Definition of Gray Scale

color(n) : n is series of Gray Scale

The more n value is, the bright Gray Scale.

(2)Data:1-High,0-Low

### 6. BLOCK DIAGRAM

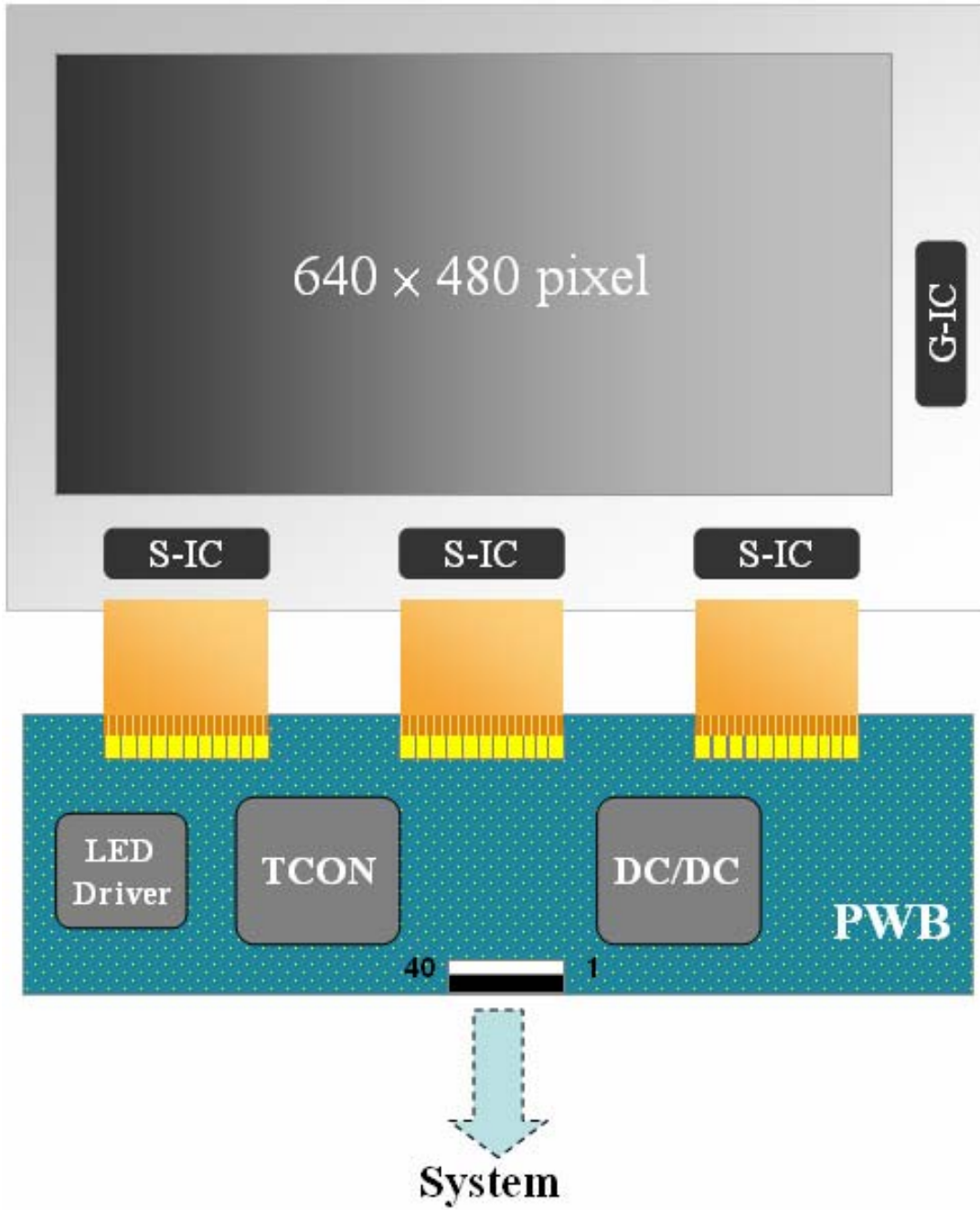

### 7. MECHANICAL DIMENSION

#### 7.1 Front Side

[Unit : mm]

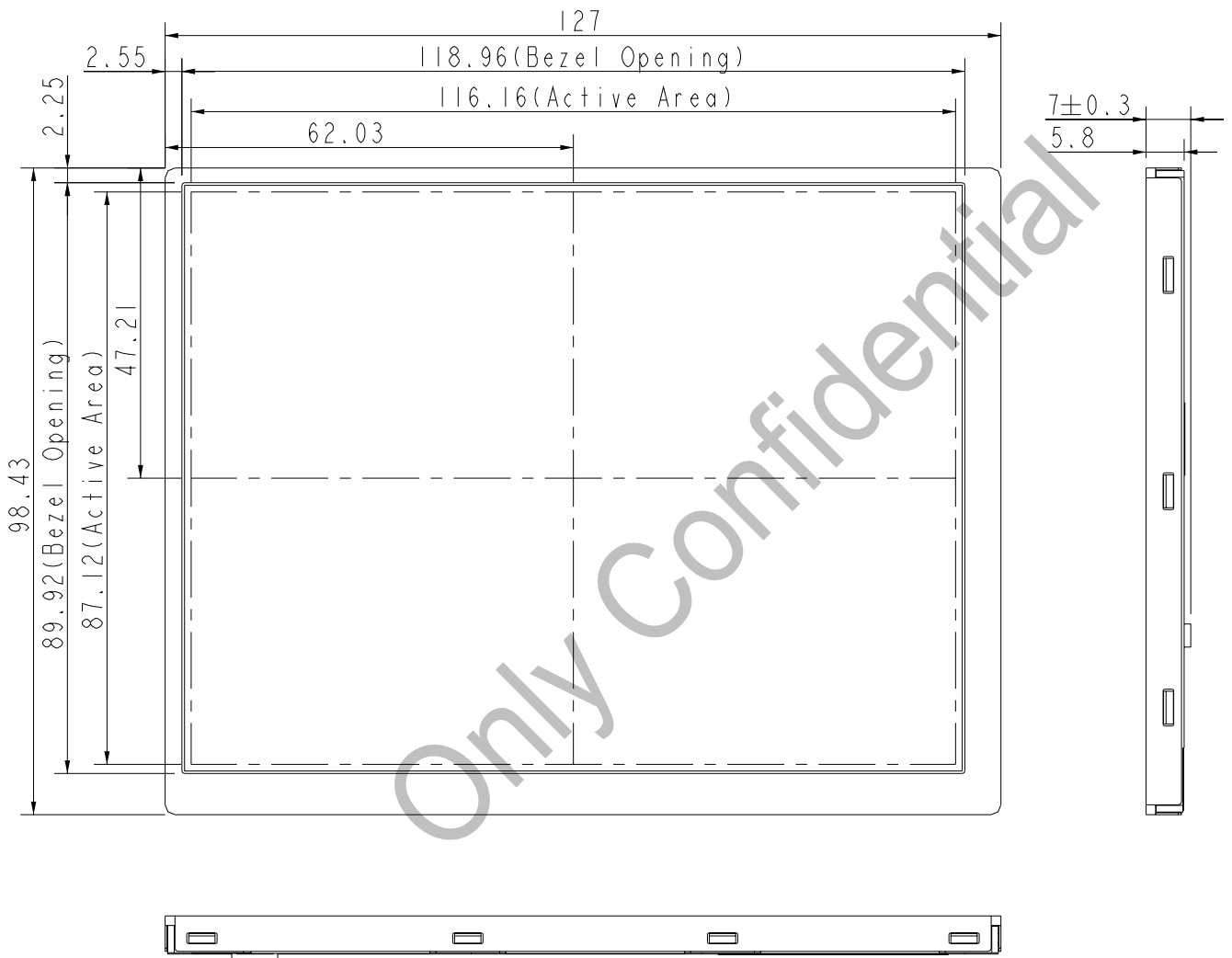

7.2 Rear Side

[Unit : mm]

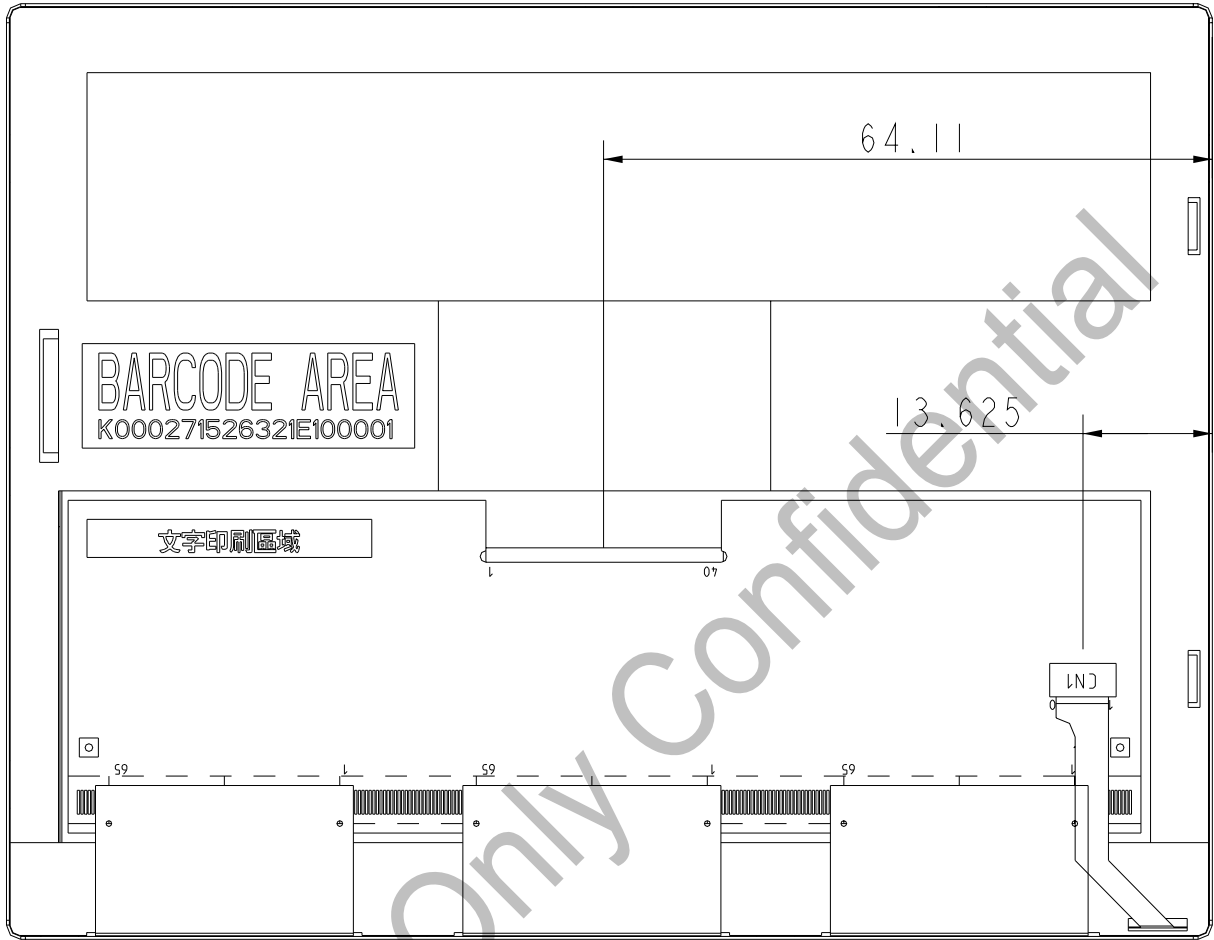

Remark : Un-indication tolerance is  $\pm 0.3\text{mm}$



## 8. OPTICAL CHARACTERISTICS

ITEM	SYMBOL	CONDITION	MIN.	TYP.	MAX.	UNIT	Remarks
Constrast Ratio	CR	Point-5	200	300	--	--	*1)*2)*3)
Luminance	Lw	Point-5	180	220	--	cd/m <sup>2</sup>	*1)*3)
Luminance Uniformity	$\Delta L$		70	80	--	%	*1)*3)
Response Time (White - Black)	Tr+ Tf	Point-5	--	30	50	ms	*1)*3)*5)
Viewing Angle	Horizontal	CR $\geq$ 10 Point-5	120	140	--	°	*1)*2)*4)
	Vertical		80	100	--	°	*1)*2)*4)
Color Coordinate	White	Wx Wy	0.273 0.289	0.313 0.329	0.353 0.369	--	*1)*3)
	Red	Rx Ry	TBD	TBD	TBD		
	Green	Gx Gy	TBD	TBD	TBD		
	Blue	Bx By	TBD	TBD	TBD		

Remarks :

\*1)Measure condition : 25°C $\pm$ 2°C , 60 $\pm$ 10%RH , under10 Lux in the dark room.BM-5A (TOPCON) , viewing angle2° , VCC=3.3V , VDD=3.3V.

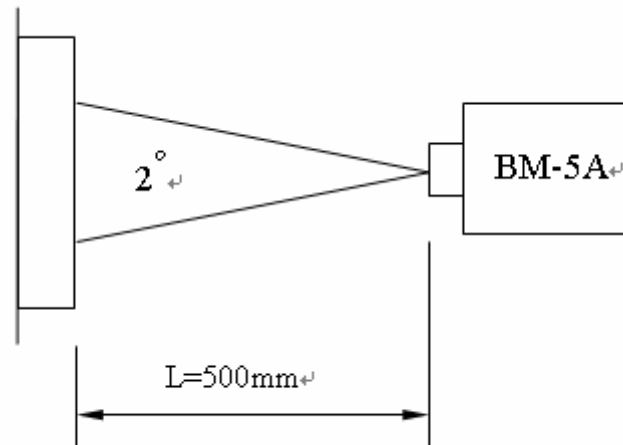

\*2) Definition of contrast ratio :

Contrast Ratio (CR)= (White) Luminance of ON  $\div$  (Black) Luminance of OFF

\*3) Definition of luminance :

Measure white luminance on the point 5 as figure8-1

Definition of Luminance Uniformity:

Measure white luminance on the point1、2、3、4、5 as figure8-1

$$\Delta L = [L(\text{MIN})/L(\text{MAX})] \times 100$$

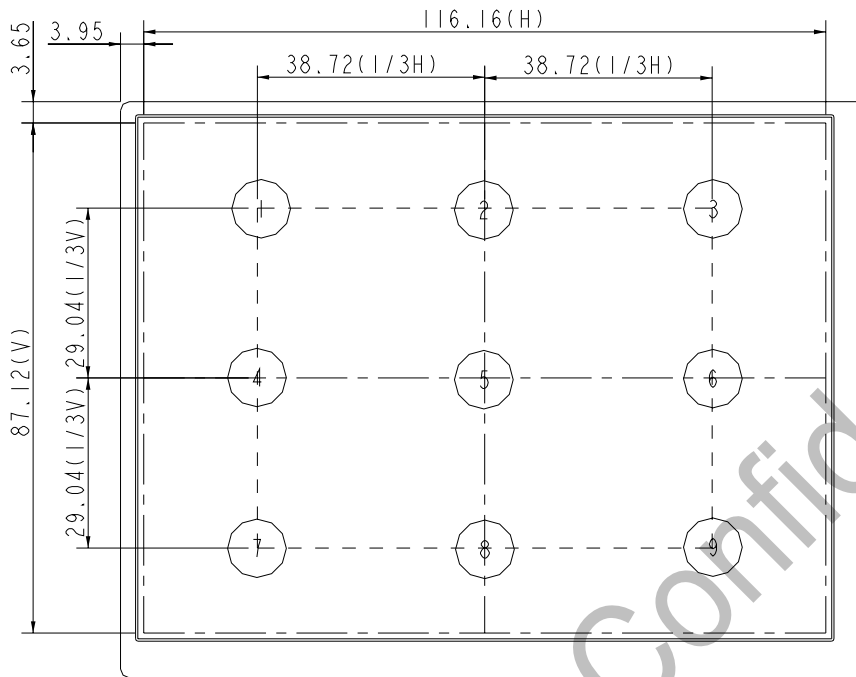

Fig8-1 Measuring point

\*4) Definition of Viewing Angle( $\theta, \psi$ ), refer to Fig8-2 as below :

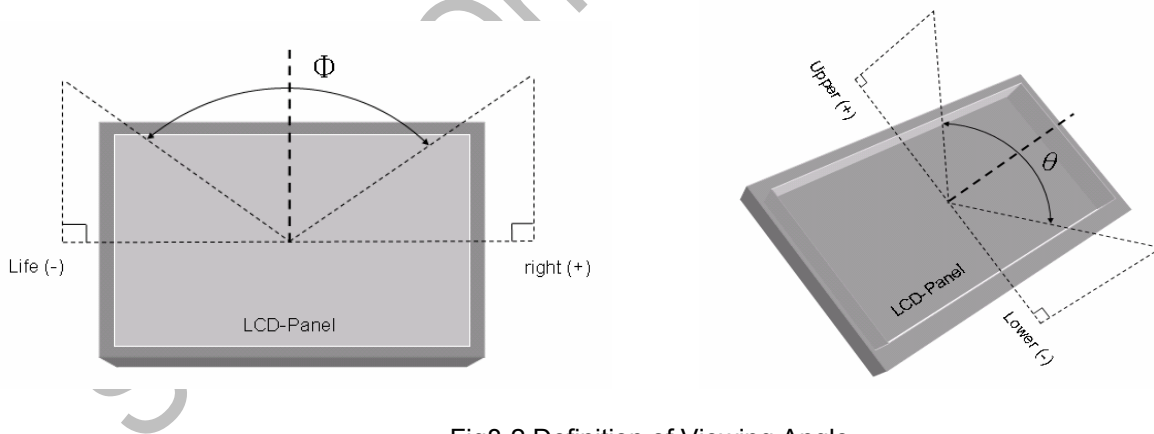

Fig8-2 Definition of Viewing Angle

\*5) Definition of Response Time.(White-Black)

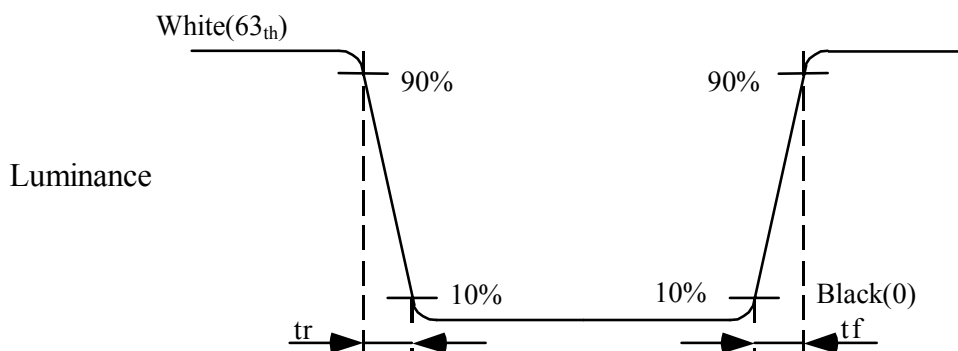

Fig8-3 Definition of Response Time(White-Black)

Only Confidential

## 9. RELIABILITY TEST

### 9-1. Temperature and humidity

TEST ITEMS	CONDITIONS
High Temperature Operation	85°C , 240H
High Temperature Storage	90°C , 240H
High Temperature High Humidity Operation	60°C , 90%RH , 240H
Low Temperature Operation	-30°C , 240H
Low Temperature Storage	-40°C , 240H
Thermal Shock	-30°C ( 1Hr ) ~ 85°C (1Hr) 200 cycles

### 9-2. Shock and Vibration

TEST ITEMS	CONDITIONS
Shock (Non-operation)	<ul style="list-style-type: none"> <li>● Shock level:980m/s<sup>2</sup>(equal to 100G)</li> <li>● Waveform:half sinusoidal wave,6ms.</li> <li>● Number of shocks:one shock input in each direction of three mutually perpendicular axes for a total of three shock inputs.</li> </ul>
Vibration (Non-operation)	<ul style="list-style-type: none"> <li>● Frequency range:8~33.3Hz</li> <li>● Stoke:1.3mm</li> <li>● Vibration:sinusodial wave,perpendicularaxis(both x,y,z axis:2Hrs).</li> <li>● Sweep:2.9G,33.3Hz-400Hz</li> <li>● Cycle:15min</li> </ul>

### 9-3. Judgment standard

The Judgment of the above test should be made as follow:

Pass:Normal display image with no obvious non-uniformity and no line defect.Partial trasformation of the module parts should be ignored.

Fail:No display image,obvious non-uniformity,or line defect.