



# Chunghwa Picture Tubes, Ltd.

## Product Specification

To : AsiaNet

Date : 081023

**TFT LCD**  
**CLAA070LC2BCW**

ACCEPTED BY : (V0.4)

Tentative

APPROVED BY	CHECKED BY	PREPARED BY

Prepared by :

Product Planning Management Division  
Small & Medium TFT Product Business Unit  
**CHUNGHWA PICTURE TUBES, LTD.**

Doc.No:	SPEC_CLAA070LC2BCW_V0.4_AsiaNet_081023	Issue Date:	2008/07/01
---------	--	-------------	------------



## CONTENTS

<b>1. OVERVIEW</b> .....	<b>4</b>
<b>2. ABSOLUTE MAXIMUM RATINGS</b> .....	<b>5</b>
<b>3. ELECTRICAL CHARACTERISTICS</b> .....	<b>6</b>
3.1 TFT LCD .....	6
3.2 TFT-LCD Current Consumption .....	6
3.3 Power 、 Signal sequence .....	7
3.4 Backlight.....	7
<b>4. INTERFACE CONNECTION</b> .....	<b>8</b>
4.1 CN1 .....	8
<b>5. INPUT SIGNAL(DE ONLY MODE)</b> .....	<b>9</b>
5.1 Timing Specification .....	9
5.2 Timing sequence (Timing chart).....	9
5.3 LVDS Input Data mapping .....	10
5.4 Color Data Assignment.....	11
<b>6. BLOCK DIAGRAM</b> .....	<b>12</b>
<b>7. MECHANICAL DIMENSION</b> .....	<b>13</b>
7.1 Front Side .....	13
7.2 Reae Side .....	13
<b>8. OPTICAL CHARACTERISTICS</b> .....	<b>14</b>
<b>9. RELIABILITY TEST</b> .....	<b>16</b>
9.1. Temperature and humidity .....	16
9.2. Shock and Vibration .....	16
9.3. ESD Test.....	16
9.4 Judgment standard.....	16

## 1. OVERVIEW

CLAA070LC2BCW is 17.67cm ( 7" ) color TFT-LCD(Thin Film Transistor Liquid Crystal Display ) module. Composed of LCD panel,driver ICs,control circuit,and LED backlight.

The 7.0"screen produces a high resolution image that is composed of 800×480 pixel elements in a stripe arrangement.Display 262K colors by 6 Bit R.G.B signal input.

General specifications are summarized in the following table :

ITEM	SPECIFICATION
Display Area (mm)	152.4(W)×91.44(H)
Number of Pixels	800(H)×3(RGB)×480(V)
Pixel Pitch (mm)	0.1905(H)×0.1905(V)
Color Pixel Arrangement	RGB vertical stripe
Display Mode	Normally white
Number of colors	262,144
Viewing Direction	6 o'clock
Response Time (Tr+Tf)	20ms
Brightness(cd/m <sup>2</sup> )	500nit(typ)
Viewing Angle(BL on,CR ≥ 10)	140 degree(H) · 110degree(V)
Electrical Interface(data)	LVDS
Power consumption	2.9W(Typ)
Outline Dimension(in mm)	163.9(W)×103.95(H)×7.95(D)(with component)
Weight(g)	TBD
BL unit	LED
Surface Treatment	Anti-Glare · Hardness:3H

## 2. ABSOLUTE MAXIMUM RATINGS

Item	Symbol	Min.	Max.	Unit	Note
Input Voltage	V <sub>cc</sub>	-0.3	4.0	V	
Signal Input Voltage	RxIN0+ ~ RxIN2+ RxIN0- ~ RxIN2- Rx CLK IN +/-	-0.3	V <sub>cc</sub> +0.3	V	
Static Electricity	VESDc	-200	+200	V	【Note1】
	VESDm	-15K	+15K	V	
ICC Rush Current	IRUSH	-	1	A	【Note2】
Forward Current ( per LED )	I <sub>f</sub>		30	mA	
Reverse Voltage ( per LED )	V <sub>R</sub>		5	V	
Pulse forward current ( per LED )	I <sub>fp</sub>		100	mA	【Note3】

**【Note1】**

Test Condition: IEC 61000-4-2 ,  
 VESDc : Contact discharge to input connector  
 VESDm : Discontact discharge to module

**【Note2】**

Control signal:High(+3.3V)→Low(GND)  
 Supply Voltage of rising time should be from R3 and C2 tune to 550 us.

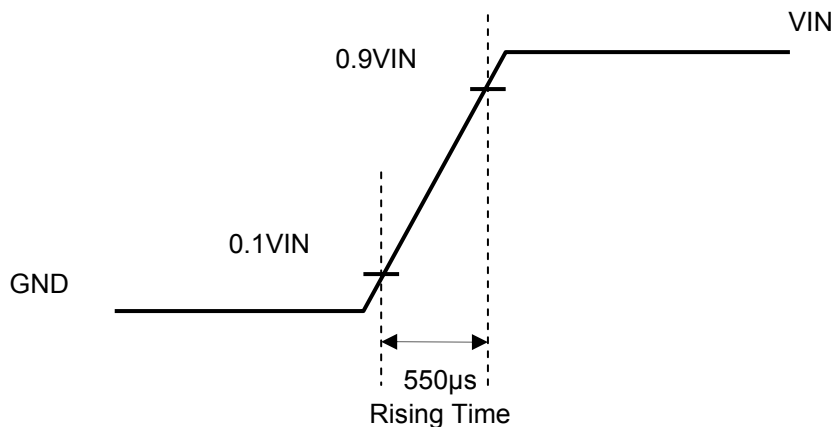
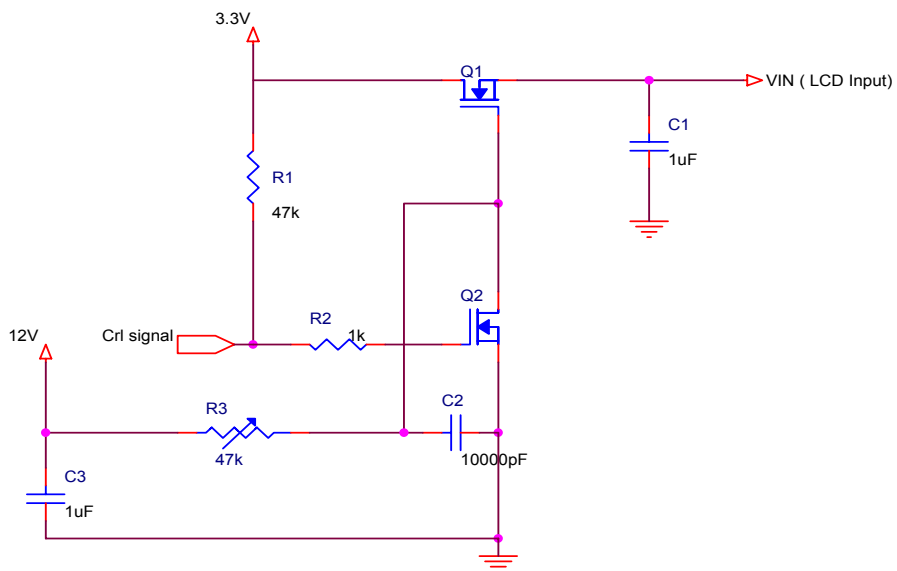

**【Note3】** I<sub>fp</sub> Conditions : Pulse Width ≤ 10msec and Duty ≤ 1/10 ◦

### 3. ELECTRICAL CHARACTERISTICS

#### 3.1 TFT LCD

Ta=25°C

Item	Symbol	Min.	Typ	Max.	Unit	Note	
Power Supply Voltage For LCD	VCC	3.0	3.3	3.6	V	【Note1】	
Logic Input Voltage (LVDS:IN+,IN-)	Input Voltage	VIN	0	-	VCC	【Note2】	
	Common Mode Voltage	VCM	1.08	1.2	1.32	V	【Note2】
	Differential Input Voltage	VID	250	350	450	mV	【Note2】
	Threshold Voltage(high)	VTH	-	-	100	mV	【Note2】 VCM=+1.2V
	Threshold Voltage(low)	VTL	-100	-	-	mV	【Note2】

【Note1】 VCC –dip codition:

- 1) When  $2.7V \leq VCC < 3.0V$ ,  $td \leq 10ms$ .
- 2)  $VCC > 3.0V$ , VCC-dip condition should be same as VCC-turn-on condition.

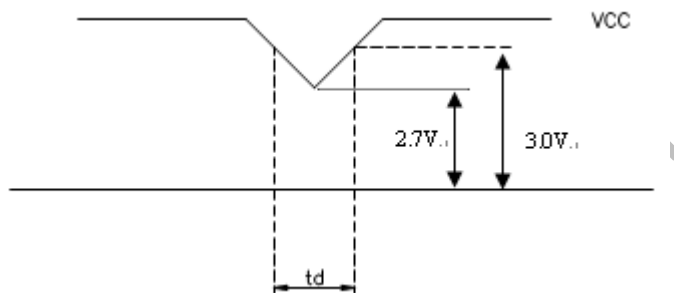

【Note2】 LVDS signal

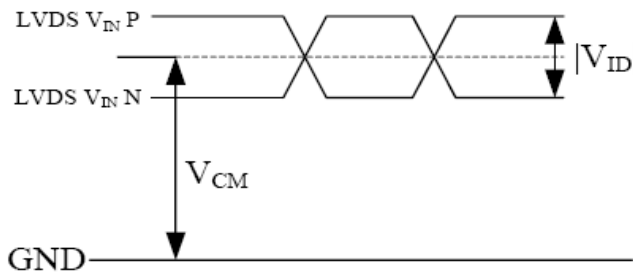

$|VID| = |VTH - VTL|$   
 $VCM = (VTH + VTL)/2$

#### 3.2 TFT-LCD Current Consumption

Item	Symbol	Min	Type	Max	Unit	Notes
LCD power current	ICC	--	150	200	mA	【Note1】

【Note1】

Typical: Under 64 gray pattern  
 Maximum: Under black pattern



(a)64 Gray Pattern

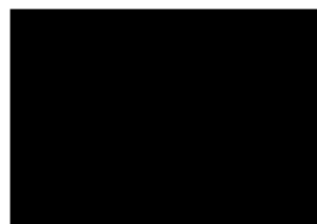

(b)Black Pattern

3.3 Power · Signal sequence

- $t1 \cong 10\text{ms}$        $1 \text{ sec} \cong t5$
- $0 \cong t2 \cong 50\text{ms}$      $200\text{ms} \cong t6$
- $0 < t3 \cong 50\text{ms}$      $200\text{ms} \cong t7$
- $0 < t4 \cong 10\text{ms}$

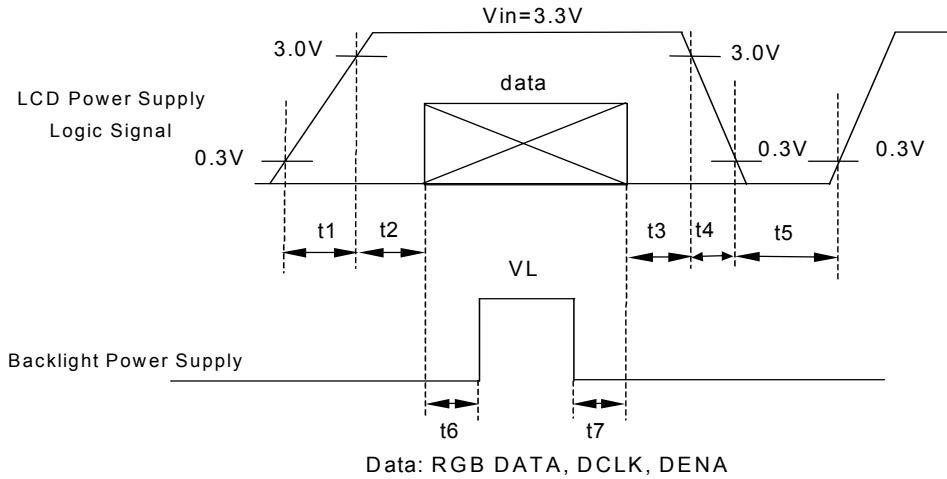

3.4 Backlight

Ta=25°C

Item	Symbol	Min.	Typ	Max.	Unit	Note
LED current	IL	--	100	--	mA	【Note1,2】
LED voltage	VL	18	19.5	(21.6)	V	【Note1,2】
Power consumption	WL	--	1.95	(2.13)	W	【Note1,2】

【Note1】 LED B/L circuit · If=100mA · A : Anode · K : Cathode ◦

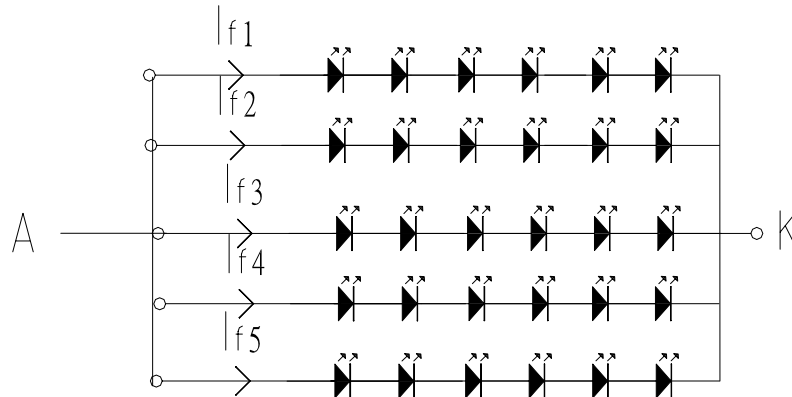

【Note2】 We suggest using the constant current control, IL=100mA, to avoid the leakage light and brightness quality issue.

## 4. INTERFACE CONNECTION

### 4.1 CN1 : Connector type : STARCONN 093F30-B0B01A

Pin NO.	SYMBOL	DESCRIPTION
1	AVSS	Power Ground
2	VCC	Power Supply for Digital circuit
3	VCC	Power Supply for Digital circuit
4	NC	NC
5	NC	NC
6	NC	NC
7	AVSS	Power Ground
8	RXIN0-	Negative LVDS differential data inputs
9	RXIN0+	Positive LVDS differential data inputs
10	AVSS	Power Ground
11	RXIN1-	Negative LVDS differential data inputs
12	RXIN1+	Positive LVDS differential data inputs
13	AVSS	Power Ground
14	RXIN2-	Negative LVDS differential data inputs
15	RXIN2+	Positive LVDS differential data inputs
16	AVSS	Power Ground
17	RXCLK-	Negative LVDS differential clock inputs
18	RXCLK+	Positive LVDS differential clock inputs
19	AVSS	Power Ground
20	NC	NC
21	NC	NC
22	AVSS	Power Ground
23	NC	NC
24	NC	NC
25	NC	NC
26	NC	NC
27	NC	NC
28	AVSS	Power Ground
29	NC	NC
30	NC	NC

Note1 : GND Pin must ground contact , can not be floating.



### 5. INPUT SIGNAL(DE ONLY MODE)

#### 5.1 Timing Specification

Item		Symbol	Min	Typ	Max	Unit	
CLK Frequency		fCLKin	25	27	32	MHz	
DENA	Horizontal	Horizontal total Time	$t_H$	850	900	950	tCLK
		Horizontal effective Time	$t_{HA}$	800	800	800	tCLK
		Horizontal Blank Time	$t_{HB}$	50	100	150	tCLK
	Vertical	Frame	fV	55	60	65	Hz
		Vertical total Time	$t_V$	490	500	520	$t_H$
		Vertical effectiveTime	$t_{VA}$	480	480	480	$t_H$
	Vertical Blank Time	$t_{VB}$	10	20	40	$t_H$	

#### 5.2 Timing sequence (Timing chart)

##### 5.2.1 Horizontal Timing Sequence

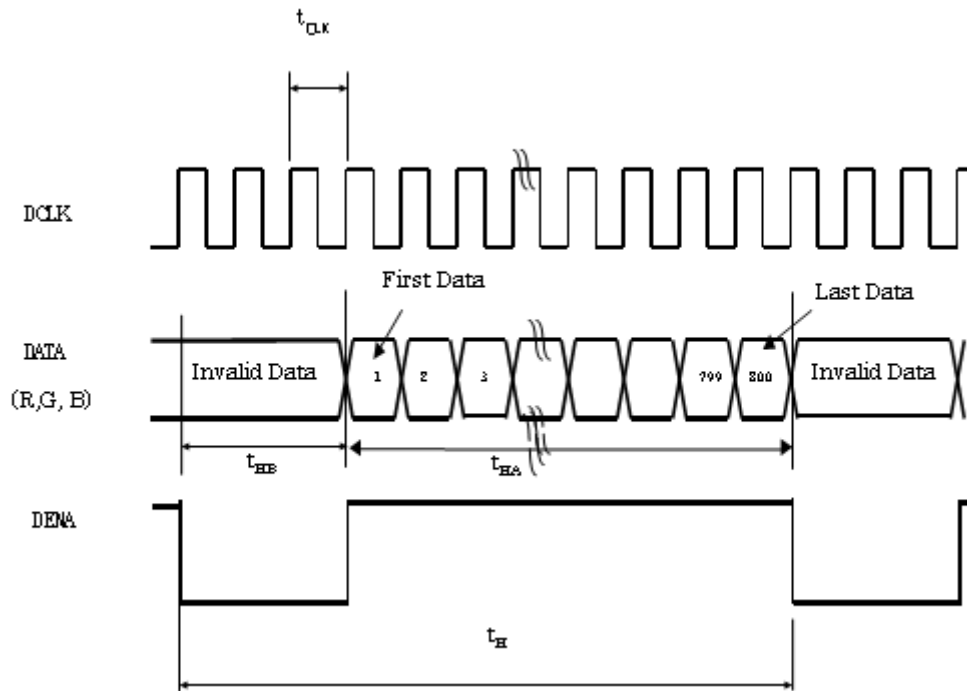

### 5.2.2 Vertical Timing Sequence

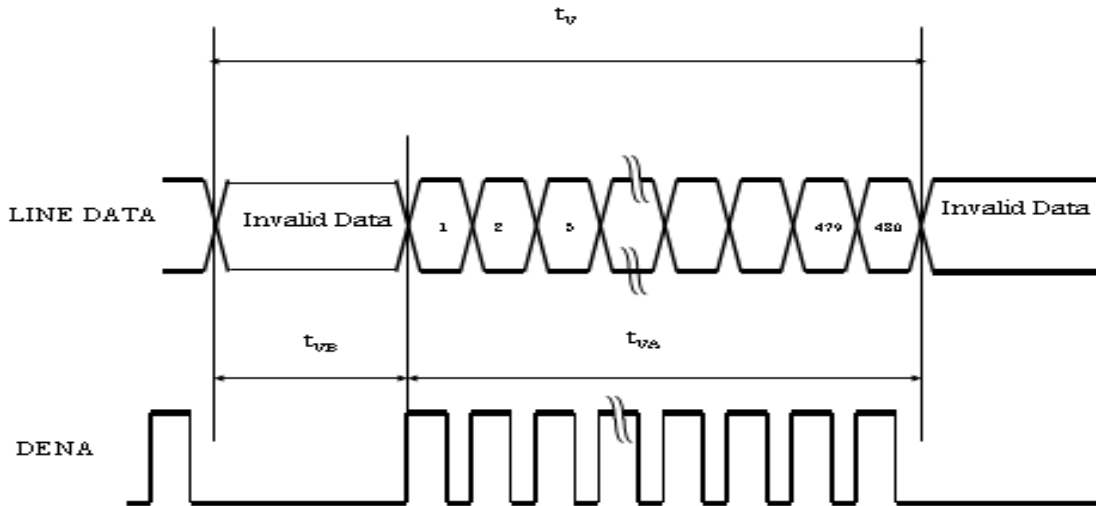

### 5.3 LVDS Input Data mapping

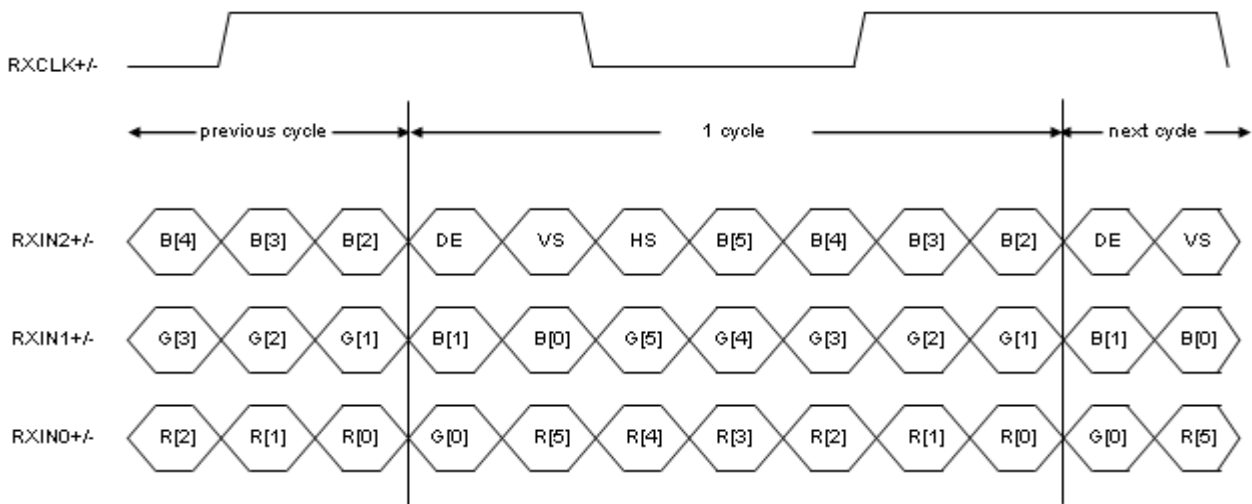

5.4 Color Data Assignment

COLOR	INPUT DATA	R DATA						G DATA						B DATA					
		R5	R4	R3	R2	R1	R0	G5	G4	G3	G2	G1	G0	B5	B4	B3	B2	B1	B0
		MSB			LSB			MSB			LSB			MSB			LSB		
BASIC COLOR	BLACK	0	0	0	0	0	0	0	0	0	0	0	0	0	0	0	0	0	0
	RED(63)	1	1	1	1	1	1	0	0	0	0	0	0	0	0	0	0	0	0
	GREEN(63)	0	0	0	0	0	0	1	1	1	1	1	1	0	0	0	0	0	0
	BLUE(63)	0	0	0	0	0	0	0	0	0	0	0	0	1	1	1	1	1	1
	CYAN	0	0	0	0	0	0	1	1	1	1	1	1	1	1	1	1	1	1
	MAGENTA	1	1	1	1	1	1	0	0	0	0	0	0	1	1	1	1	1	1
	YELLOW	1	1	1	1	1	1	1	1	1	1	1	1	0	0	0	0	0	0
	WHITE	1	1	1	1	1	1	1	1	1	1	1	1	1	1	1	1	1	1
RED	RED(0)	0	0	0	0	0	0	0	0	0	0	0	0	0	0	0	0	0	0
	RED(1)	0	0	0	0	0	1	0	0	0	0	0	0	0	0	0	0	0	0
	RED(2)	0	0	0	0	1	0	0	0	0	0	0	0	0	0	0	0	0	0
	RED(62)	1	1	1	1	1	0	0	0	0	0	0	0	0	0	0	0	0	0
	RED(63)	1	1	1	1	1	1	0	0	0	0	0	0	0	0	0	0	0	0
GREEN	GREEN(0)	0	0	0	0	0	0	0	0	0	0	0	0	0	0	0	0	0	0
	GREEN(1)	0	0	0	0	0	0	0	0	0	0	0	1	0	0	0	0	0	0
	GREEN(2)	0	0	0	0	0	0	0	0	0	0	1	0	0	0	0	0	0	0
	GREEN(62)	0	0	0	0	0	0	1	1	1	1	1	0	0	0	0	0	0	0
GREEN(63)	0	0	0	0	0	0	1	1	1	1	1	1	0	0	0	0	0	0	
BLUE	BLUE(0)	0	0	0	0	0	0	0	0	0	0	0	0	0	0	0	0	0	0
	BLUE(1)	0	0	0	0	0	0	0	0	0	0	0	0	0	0	0	0	0	1
	BLUE(2)	0	0	0	0	0	0	0	0	0	0	0	0	0	0	0	0	1	0
	BLUE(62)	0	0	0	0	0	0	0	0	0	0	0	0	1	1	1	1	1	0
BLUE(63)	0	0	0	0	0	0	0	0	0	0	0	0	1	1	1	1	1	1	

[Note] (1) Definition of Gray Scale ,color(n) : n is series of Gray Scale  
 The more n value is, the bright Gray Scale.  
 (2)Data:1-High,0-Low

### 6. BLOCK DIAGRAM

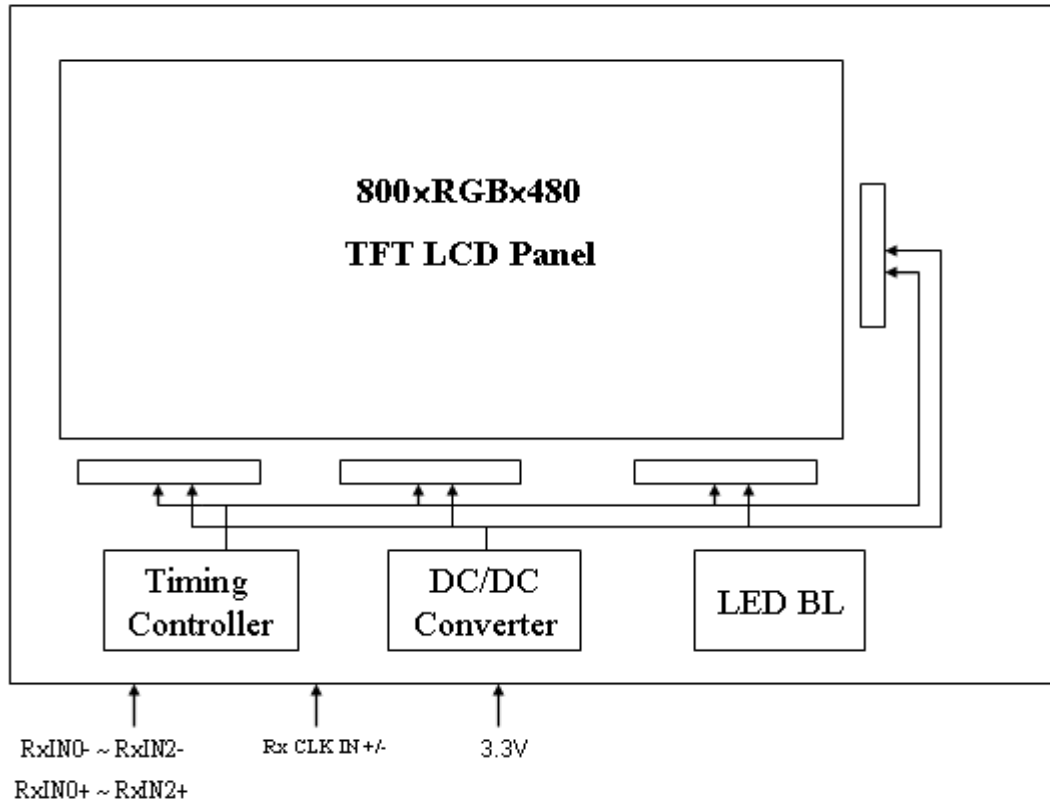

### 7. MECHANICAL DIMENSION

#### 7.1 Front Side

[Unit : mm]

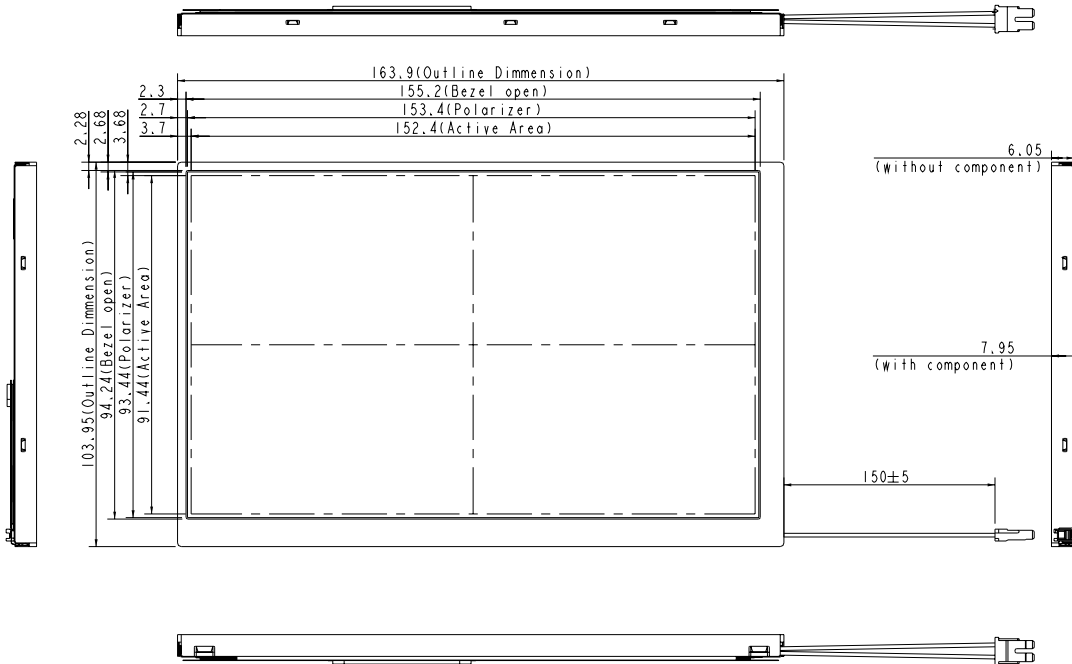

General Tolerance = ±0.3

#### 7.2 Reae Side

[Unit : mm]

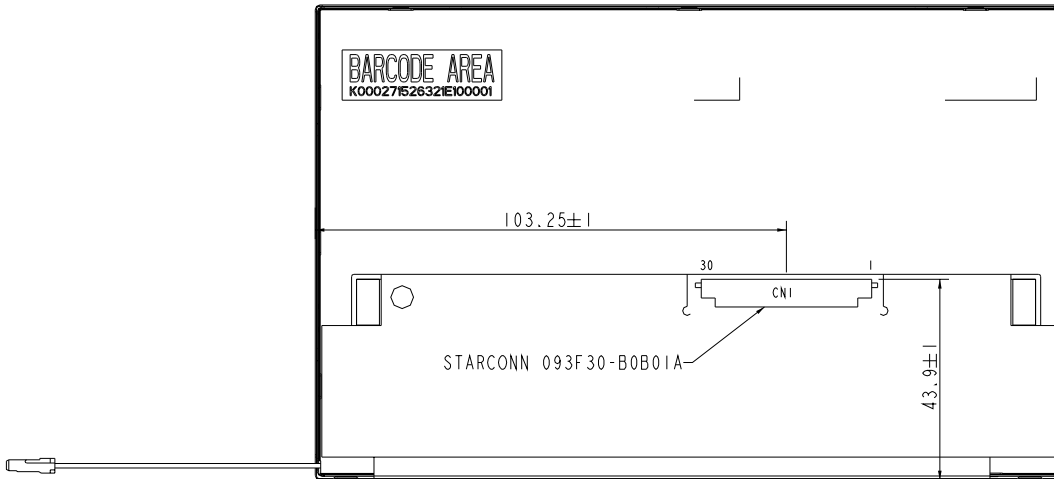

Note1:Un-indication tolerance is ±0.3mm

Note2:CN2 Type : STARCONN 093F30-B0B01A

Note 3 :Anode : black cable , Cathode : white cable

## 8. OPTICAL CHARACTERISTICS

ITEM	SYMBOL	CONDITION	MIN.	TYP.	MAX.	UNIT	Remarks
Constrast Ratio	CR	Point-5	300	400	--	--	*1)*2)*3)
Luminance (CEN)	Lw	Point-5	400	500	--	cd/m <sup>2</sup>	*1)*3)
Luminance Uniformity	$\Delta L$		70	80	--	%	*1)*3)
Response Time (White - Black)	Tr+ Tf	Point-5	--	--	20	ms	*1)*3)
Viewing Angle	Horizontal	CR $\geq$ 10 Point-5	120	140	--	°	*1)*2)
	Vertical		90	110	--	°	*1)*2)
Color Coordinate	White	Point-5	0.273	0.313	0.353	--	*1)*3)
			0.289	0.329	0.369		
	Red		0.535	0.575	0.615		
			0.292	0.332	0.372		
Green	Gx Gy	0.290	0.330	0.370			
		0.525	0.565	0.605			
Blue	Bx By	0.110	0.150	0.190			
		0.080	0.120	0.160			

### [Note]

\*1) These items are measured by BM-5A (TOPCON) in the dark room. (no ambient light), viewing cone = 2° , 25°C $\pm$ 2°C · 60 $\pm$ 10%RH, VCC=3.3V and IL=100mA, after 10 minutes operation.

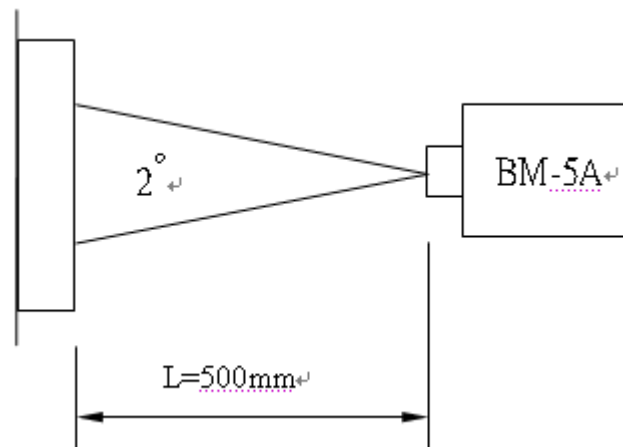

\*2) Definition of contrast ratio : Measure contrast ratio on the # 5 points (refer to figure1) .

Contrast ratio is calculated with the following formula :

Contrast Ratio (CR)= (White) Luminance of ON  $\div$  (Black) Luminance of OFF

\*3) Definition of Luminance Uniformity : Measure maximum luminance(L(MAX) )and minimum luminance (L(MIN) ) on the 9 points as figure 1(#1~#9 poin).

Luminance Uniformity is calculated with the following formula :

$$\Delta L = (L(MIN) \div L (MAX)) \times 100$$

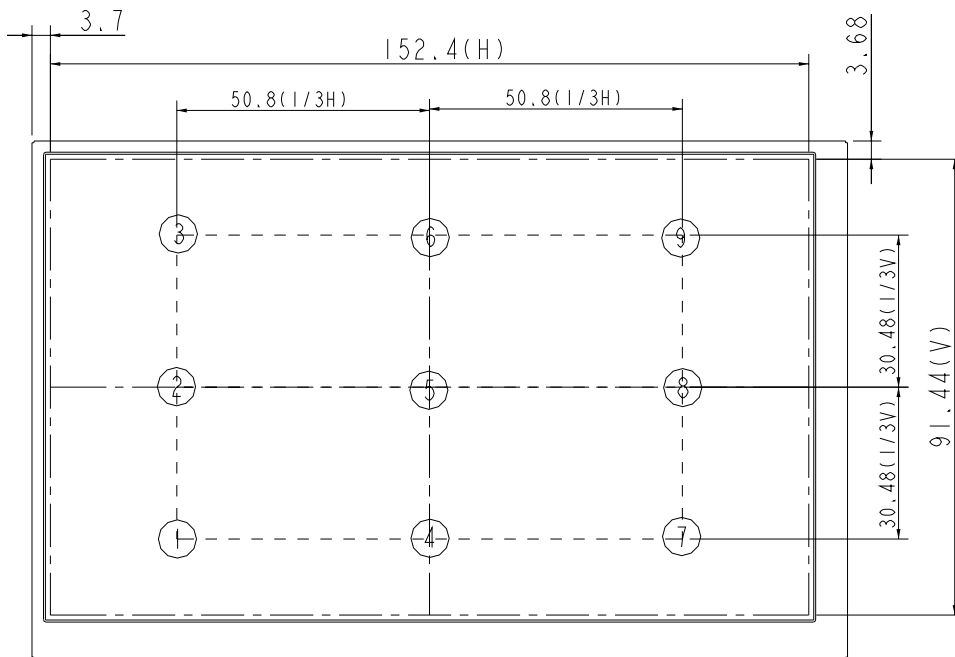

Fig.1 Measuring point

\*4) Definition of Viewing Angle( $\theta, \psi$ ),refer to Fig.2 as below : (EZ-CONTRAST (ELDIM))

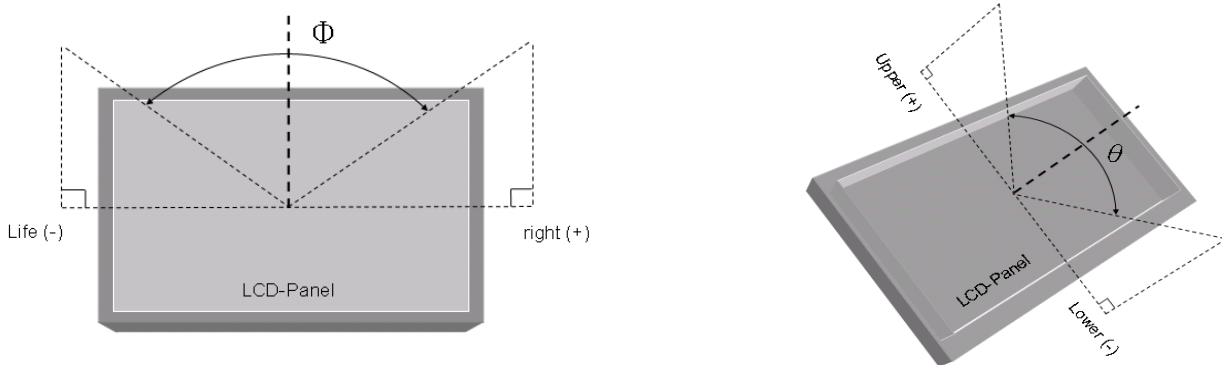

Fig.2 Definition of Viewing Angle

\*5) Definition of Response Time.

The response time is defined as the time interval between the 10% and 90% amplitudes.Refer to figure 3 as below.

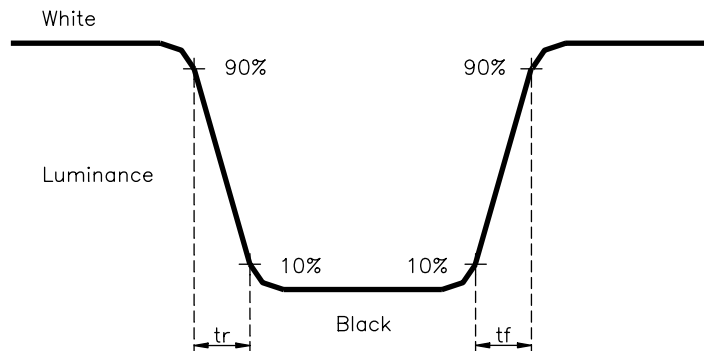

Fig.3 Definition of Response Time

## 9. RELIABILITY TEST

### 9.1. Temperature and humidity

TEST ITEMS	CONDITIONS	REMARK
High Temperature Operation	85°C , 1000Hrs	
High Temperature Storage	90°C , 1000Hrs	
High Temperature High Humidity Operation	60°C , 90%RH , 1000Hrs	No condensation
Low Temperature Operation	-30°C , 1000Hrs	
Low Temperature Storage	-40°C , 1000Hrs	
Thermal Shock	-30°C ( 1.0Hr ) ~ 85°C (1.0Hr) 200 cycles	

### 9.2. Shock and Vibration

TEST ITEMS	CONDITIONS
Shock (Non-operation)	<ul style="list-style-type: none"> <li>● Shock level:980m/s<sup>2</sup>(equal to 100G)</li> <li>● Waveform:half sinusoidal wave,6ms.</li> <li>● Number of shocks:one shock input in each direction of three mutually perpendicular axes for a total of three shock inputs.</li> </ul>
Vibration (Non-operation)	<ul style="list-style-type: none"> <li>● Frequency range:8~33.3Hz</li> <li>● Stroke:1.3mm</li> <li>● Vibration:sinusoidal wave,perpendicularaxis(both x, z axis:2Hrs, y axis 4Hrs).</li> <li>● Sweep:2.9G,33.3Hz-400Hz</li> <li>● Cycle:15min</li> </ul>

### 9.3. ESD Test

ITEM	CONDITION	REMARK
ESD	150pF , 330Ω , ±8KV&±15KV air & contact test	*1)
	200pF , 0Ω , ±250V contact test	*2)

Remarks :

\*1) LCD glass and metal bezel

\*2) IF connector pins

### 9.4 Judgment standard

The Judgment of the above test should be made as follow:

Pass:Normal display image with no obvious non-uniformity and no line defect.Partial transformation of the module parts should be ignored.

Fail:No display image,obvious non-uniformity,or line defect.