



Chunghwa Picture Tubes, Ltd.

Product Specification

To :

TFT LCD
CLAA070NA01CW

ACCEPTED BY : (V0.0)

Tentative

APPROVED BY	CHECKED BY	PREPARED BY

Prepared by :

Product Planning Management Division
Small & Medium TFT Product Business Unit
CHUNGHWA PICTURE TUBES, LTD.

Doc.No: SPEC_CLAA070NA01CW_V0.0_AsiaNet_081023

Issue Date:

2008/04/15

REVISION STATUS

Revision Notice	Description	Page	Rev. Date
0.0	First revision	--	2008.04.15

CONTENTS

1. OVERVIEW	4
2. ABSOLUTE MAXIMUM RATINGS	5
3. ELECTRICAL CHARACTERISTICS	6
3.1 TFT LCD	6
3.2 TFT-LCD Current Consumption	7
3.3 Power 、 signal sequence.....	7
4. INTERFACE CONNECTION	8
5. INPUT SIGNAL(DE ONLY MODE)	10
5.1 Timing Specification	10
5.2 Timing sequence(Timing chart).....	11
5.3 LVDS Input Data mapping	12
5.4 Color Data Assignment.....	13
6. BLOCK DIAGRAM	14
7. MECHANICAL DIMENSION	15
7.1 Front Side	15
7.2 Rear Side	15
8. OPTICAL CHARACTERISTICS	16
9. RELIABILITY TEST	19
9.1. Temperature and humidity	19
9.2. Shock and Vibration	19
9.3 Judgment standard.....	19

1. OVERVIEW

CLAA070NA01CW is 7" color TFT-LCD(Thin Film Transistor Liquid Crystal Display)module composed of LCD panel,driver ICs,control circuit,and LED backlight.

The 7.0"screen produces a high resolution image that is composed of 1024×600 pixel elements in a stripe arrangement.Display 262K colors by 6 Bit R.G.B signal input.

General specifications are summarized in the following table :

ITEM	SPECIFICATION
Display Area (mm)	153.6(H)×90(V)
Number of Pixels	1024(H)×3(RGB)×600(V)
Pixel Pitch (mm)	0.15(H)×0.15(V)
Color Pixel Arrangement	RGB vertical stripe
Display Mode	Normally white
Number of colors	262,144
Viewing Direction	6 o'clock
Response Time (Tr+Tf)	20ms(typ.)/30ms(max.)
Brightness(cd/m ²)	280 nit(min)/350nit(typ)
Viewing Angle(BL on,CR≥10)	140 degree(H) , 110degree(V)
Electrical Interface(data)	LVDS
Power consumption	2.825W (TYP)
Outline Dimension(in mm)	165(W)×102(H)×4.9(D)
Weight(g)	110
BL unit	LED
Surface Treatment	Anti-Glare , Hardness:3H

2. ABSOLUTE MAXIMUM RATINGS

Item	Symbol	Min.	Max.	Unit	Note
LCD input Voltage	Vcc	-0.3	4.0	V	
LED input Voltage	VLED	-0.3	6	V	
Signal Input Voltage	RxIN0+ ~ RxIN2+ RxIN0- ~ RxIN2- Rx CLK IN +/-	-0.3	Vcc+0.3	V	
Static Electricity	VESDc	-200	+200		*2)
	VESDm	-15K	+15K	V	
ICC Rush Current	IRUSH	--	1	A	*3)
Operation Temperature	T _{op}	-30	85	°C	*1)
Storage Temperature	T _{stg}	-40	95	°C	*1)

Remarks :

- *1) If users use the product out off the environment operation range (temperature and humidity) ,it will concern for visual quality.
- *2) Test Condition: IEC 61000-4-2 ,
VESDc : Contact discharge to input connector
VESDm : Contact discharge to module
- *3) Control signal:High(+3.3V)→Low(GND)
Supply Voltage of rising time should be from R3 and C2 tune to 550 us.

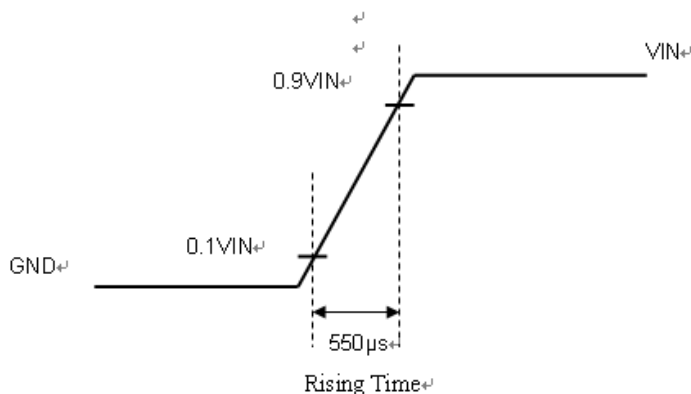
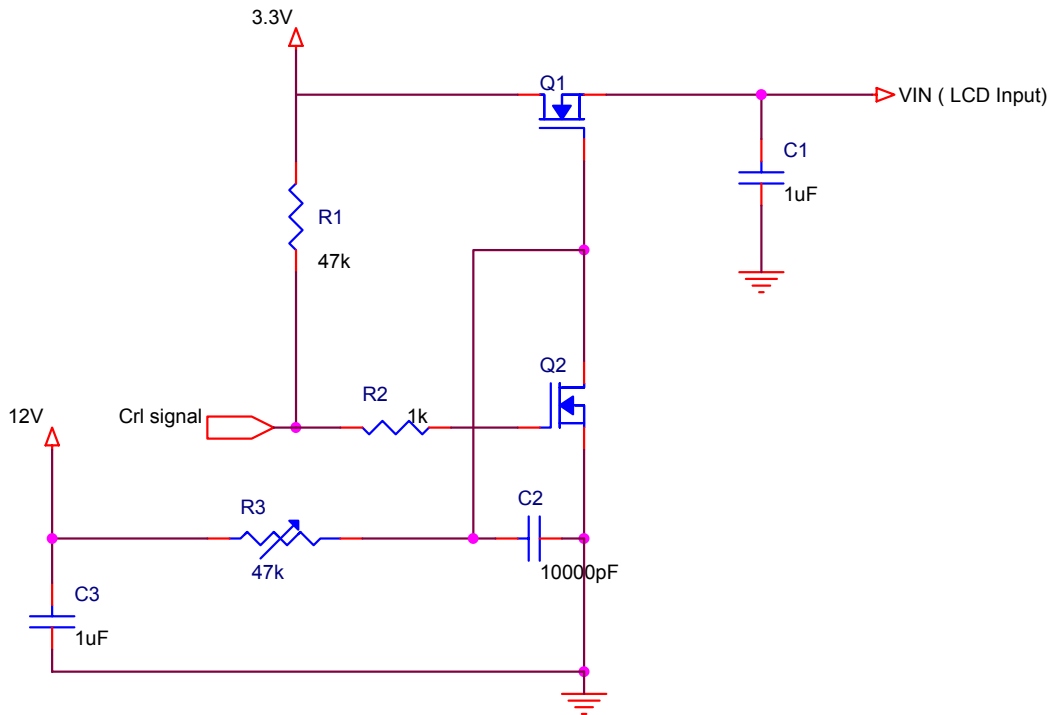

3. ELECTRICAL CHARACTERISTICS

3.1 TFT LCD

Ta=25°C

Item	Symbol	Min.	Typ	Max.	Unit	Note
Power Supply Voltage For LCD	VCC	3.0	3.3	3.6	V	
Power Supply Voltage For LED	VLED	4.5	5.0	5.5		
Logic Input Voltage (LVDS:IN+,IN-)	VCM	1.08	1.2	1.32	V	*1)
	VID	250	350	450	mV	*1)
	VTH	--	--	100	mV	*1)
	VTL	-100	--	--	mV	*1) When VCM=+1.2V
ADJ Input Voltage	VIH	3.0		3.3	V	
	VIL	GND		0.3	V	

Remarks :

*1) LVDS signal

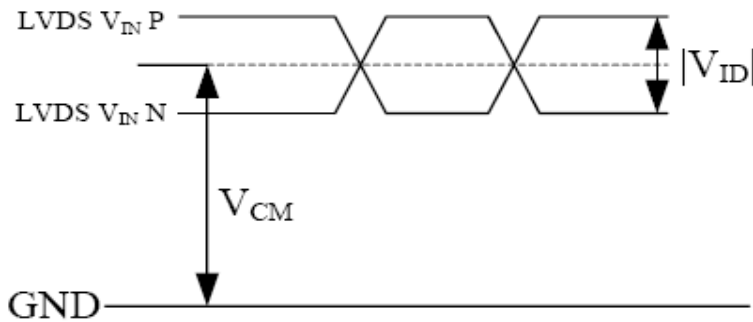

$$|VID| = |VTH - VTL|,$$

$$VCM = (VTH + VTL)/2$$

3.2 TFT-LCD Current Consumption

ITEM	SYMBOL	MIN	TYP	MAX	UNIT	REMARK
LCD Power Current	ICC	--	250	300	mA	*1)
LED Power Current	IDD		400	450	mA	*2)

*1) Typical: Under 64 gray pattern
 Maximum: Under black pattern



(a)64 Gray Pattern



(b)Black Pattern

*2) Typical: When VDD is 5V
 Maximum: When VDD is 4.5V

3.3 Power & signal sequence

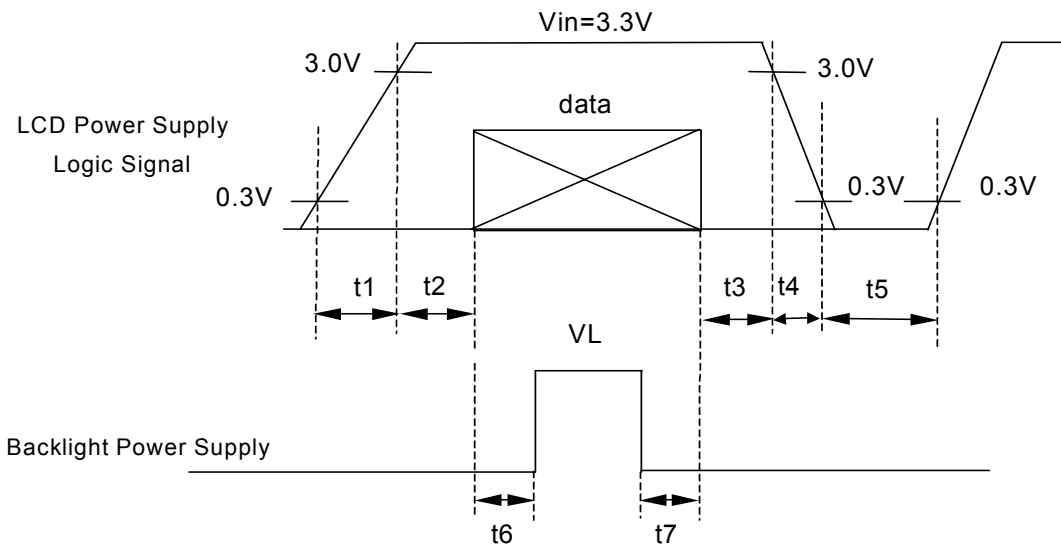

Data: RGB DATA, DCLK, DENA

- t1 ≤ 10ms
- 0 < t2 ≤ 50ms
- 0 < t3 ≤ 50ms
- 0 < t4 ≤ 10ms
- 1 sec ≤ t5
- 200ms ≤ t6
- 200ms ≤ t7

4. INTERFACE CONNECTION

Pin NO.	SYMBOL	DESCRIPTION
1	AVSS	Power Ground
2	VCC	Power Supply for Digital circuit
3	VCC	Power Supply for Digital circuit
4	NC	NC
5	ADJ	Adjust for LED brightness
6	NC	NC
7	AVSS	Power Ground
8	RXIN0-	Negative LVDS differential data inputs
9	RXIN0+	Positive LVDS differential data inputs
10	AVSS	Power Ground
11	RXIN1-	Negative LVDS differential data inputs
12	RXIN1+	Positive LVDS differential data inputs
13	AVSS	Power Ground
14	RXIN2-	Negative LVDS differential data inputs
15	RXIN2+	Positive LVDS differential data inputs
16	AVSS	Power Ground
17	RXCLK-	Negative LVDS differential clock inputs
18	RXCLK+	Positive LVDS differential clock inputs
19	AVSS	Power Ground
20	NC	NC
21	NC	NC
22	NC	NC
23	NC	NC
24	VLED	Power Supply for LED($V_{led}=5.0\pm 0.5$)
25	VLED	Power Supply for LED($V_{led}=5.0\pm 0.5$)
26	VLED	Power Supply for LED($V_{led}=5.0\pm 0.5$)
27	NC	NC
28	NC	NC
29	NC	NC
30	NC	NC

Remarks :

- 1) NC Pin must be retain, this pin can't contact GND or other signal.
- 2) GND Pin must ground contact , can not be floating.
- 3) ADJ adjust brightness to control Pin , Pulse duty the more big the more bright

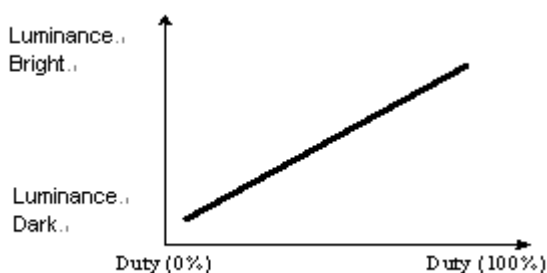

4) ADJ signal=0~3.3V , operation frequency : 20±5KHz

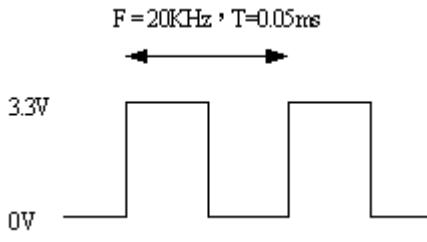

5. INPUT SIGNAL(DE ONLY MODE)

5.1 Timing Specification

Item		Symbol	Min	Typ	Max	Unit	
LVDS input signal sequence	CLK Frequency		fCLKin	39	45	52	MHz
LCD input signal sequence (Input LVDS Transmitter)	Horizontal	Horizontal total Time	t_H	1150	1200	1250	tCLK
		Horizontal effective Time	t_{HA}	1024			tCLK
		Horizontal Blank Time	t_{HB}	126	176	226	tCLK
	Vertical	Frame	fV	55	60	65	Hz
		Vertical total Time	t_V	610	625	640	t_H
		Vertical effectiveTime	t_{VA}	600			t_H
		Vertical Blank Time	t_{VB}	10	25	50	t_H

5.2 Timing sequence(Timing chart)

5.2.1 Horizontal Timing Sequence

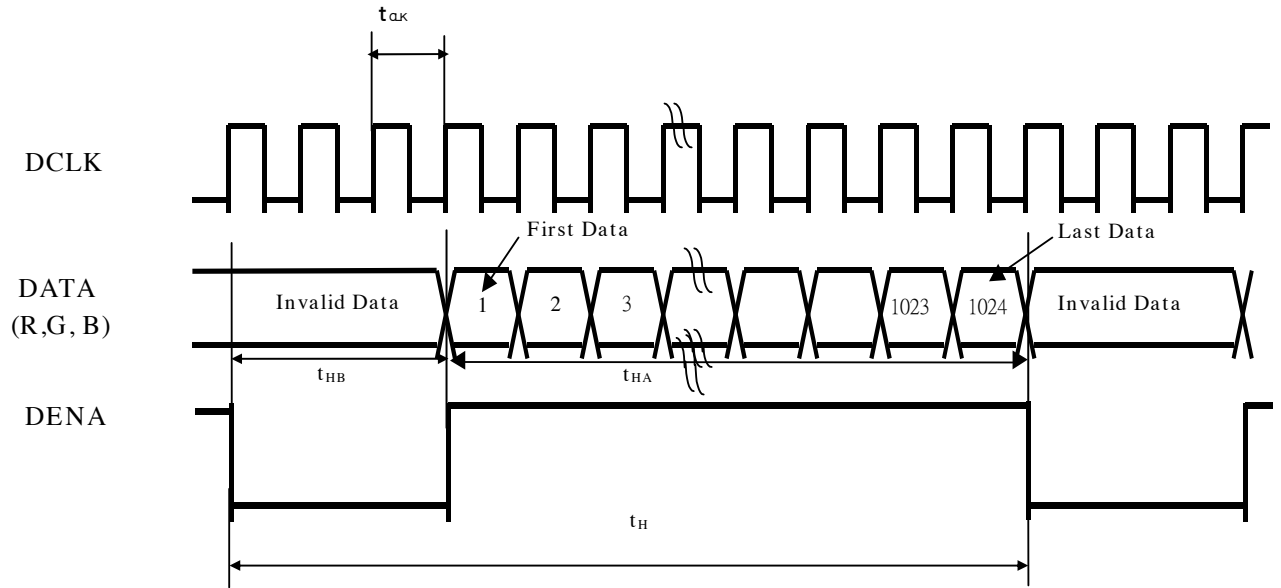

5.2.2 Vertical Timing Sequence

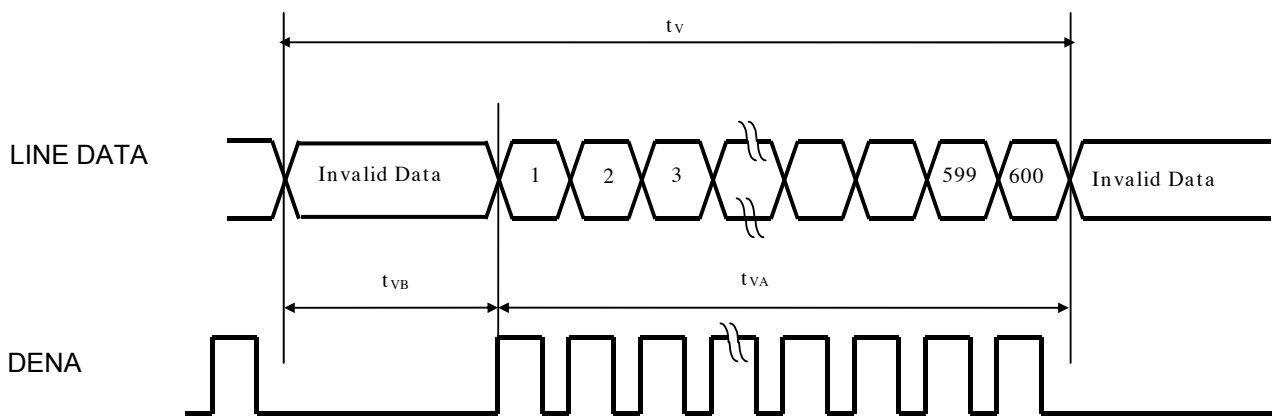

5.3 LVDS Input Data mapping

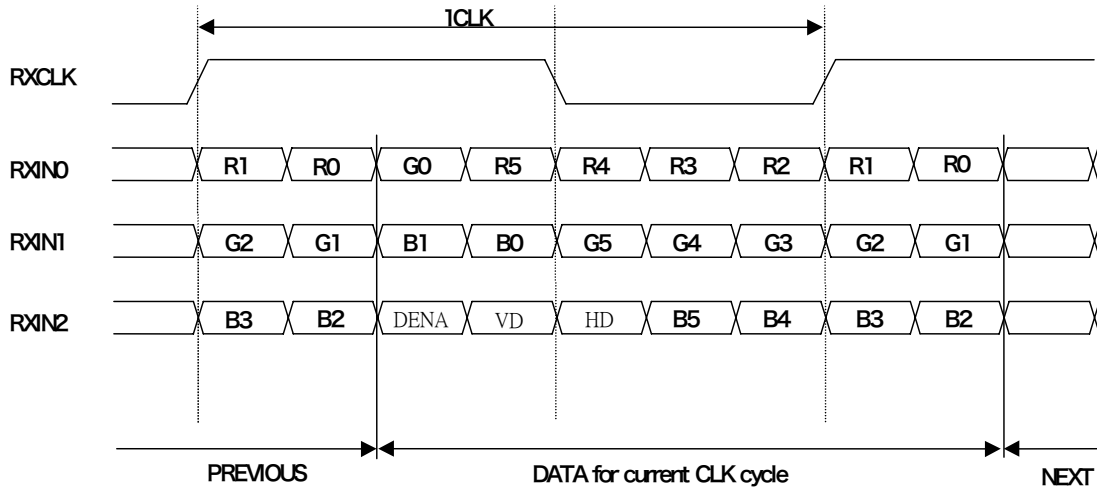

5.4 Color Data Assignment

COLOR	INPUT DATA	R DATA						G DATA						B DATA					
		R5	R4	R3	R2	R1	R0	G5	G4	G3	G2	G1	G0	B5	B4	B3	B2	B1	B0
		MSB					LSB	MSB					LSB	MSB					LSB
BASIC COLOR	BLACK	0	0	0	0	0	0	0	0	0	0	0	0	0	0	0	0	0	0
	RED(63)	1	1	1	1	1	1	0	0	0	0	0	0	0	0	0	0	0	0
	GREEN(63)	0	0	0	0	0	0	1	1	1	1	1	1	0	0	0	0	0	0
	BLUE(63)	0	0	0	0	0	0	0	0	0	0	0	0	1	1	1	1	1	1
	CYAN	0	0	0	0	0	0	1	1	1	1	1	1	1	1	1	1	1	1
	MAGENTA	1	1	1	1	1	1	0	0	0	0	0	0	1	1	1	1	1	1
	YELLOW	1	1	1	1	1	1	1	1	1	1	1	1	0	0	0	0	0	0
	WHITE	1	1	1	1	1	1	1	1	1	1	1	1	1	1	1	1	1	1
RED	RED(0)	0	0	0	0	0	0	0	0	0	0	0	0	0	0	0	0	0	0
	RED(1)	0	0	0	0	0	1	0	0	0	0	0	0	0	0	0	0	0	0
	RED(2)	0	0	0	0	1	0	0	0	0	0	0	0	0	0	0	0	0	0
	RED(62)	1	1	1	1	1	0	0	0	0	0	0	0	0	0	0	0	0	0
	RED(63)	1	1	1	1	1	1	0	0	0	0	0	0	0	0	0	0	0	0
GREEN	GREEN(0)	0	0	0	0	0	0	0	0	0	0	0	0	0	0	0	0	0	0
	GREEN(1)	0	0	0	0	0	0	0	0	0	0	0	1	0	0	0	0	0	0
	GREEN(2)	0	0	0	0	0	0	0	0	0	0	1	0	0	0	0	0	0	0
	GREEN(62)	0	0	0	0	0	0	1	1	1	1	1	0	0	0	0	0	0	0
GREEN(63)	0	0	0	0	0	0	1	1	1	1	1	1	0	0	0	0	0	0	
BLUE	BLUE(0)	0	0	0	0	0	0	0	0	0	0	0	0	0	0	0	0	0	0
	BLUE(1)	0	0	0	0	0	0	0	0	0	0	0	0	0	0	0	0	0	1
	BLUE(2)	0	0	0	0	0	0	0	0	0	0	0	0	0	0	0	0	1	0
	BLUE(62)	0	0	0	0	0	0	0	0	0	0	0	0	1	1	1	1	1	0
BLUE(63)	0	0	0	0	0	0	0	0	0	0	0	0	1	1	1	1	1	1	

Remarks :

- (1) Definition of Gray Scale
color(n) : n is series of Gray Scale
The more n value is, the bright Gray Scale.
- (2)Data:1-High,0-Low

6. BLOCK DIAGRAM

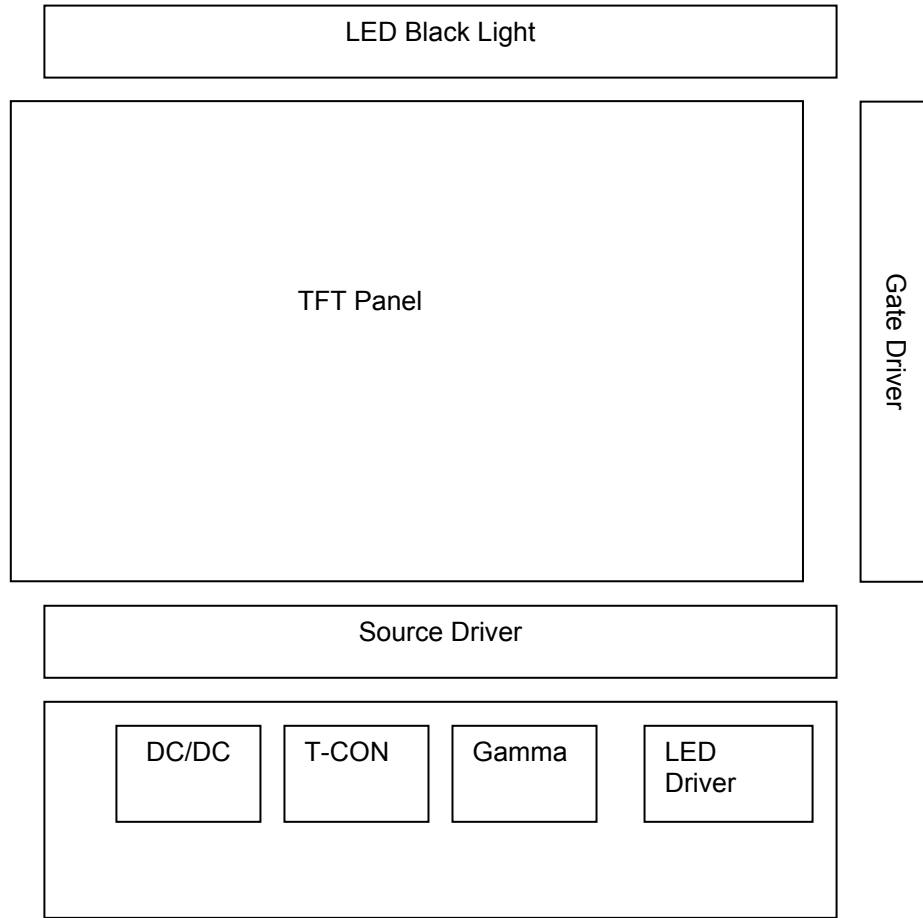

7. MECHANICAL DIMENSION

7.1 Front Side

[Unit : mm]

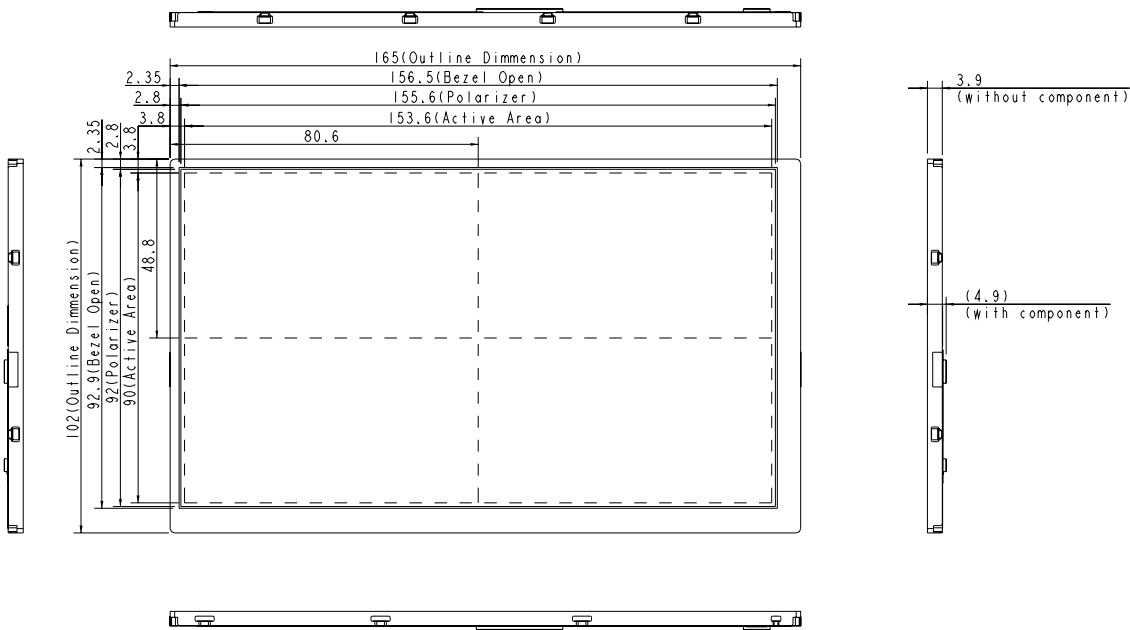

Note: General tolerance : $\pm 0.3\text{mm}$

7.2 Rear Side

[Unit : mm]

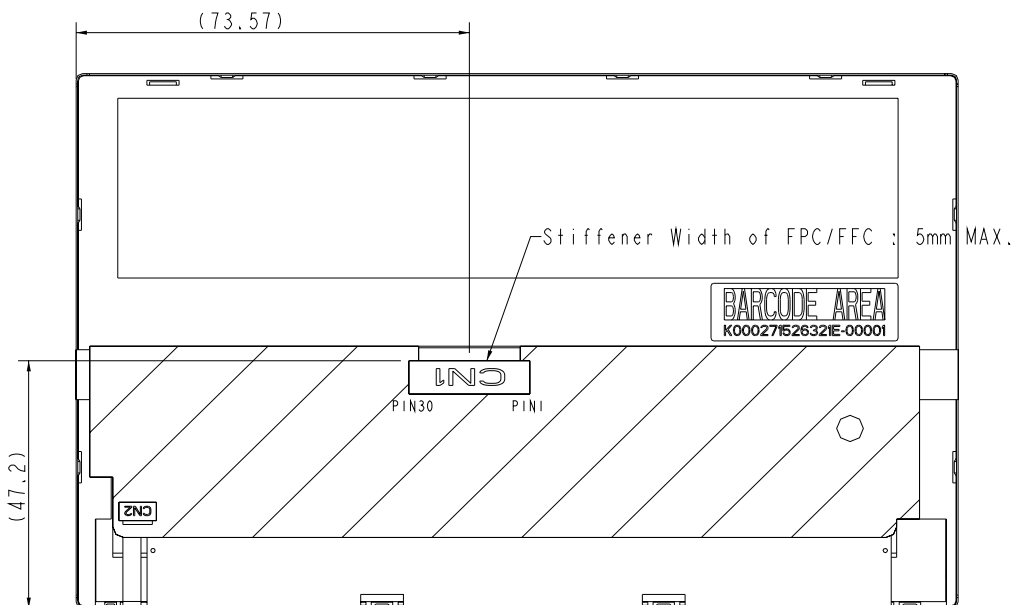

Note :

1. General tolerance : $\pm 0.3\text{mm}$
2. LCD connector CN1(30pin) : STARCONN , P/N : 089N30-000R00-G2

8. OPTICAL CHARACTERISTICS

ITEM	SYMBOL	CONDITION	MIN.	TYP.	MAX.	UNIT	Remarks	
Constrast Ratio	CR	Point-5	300	400	--	--	*1)*2)*3)	
Luminance*)	Lw	Point-5	280	350	--	cd/m ²	*1)*3)	
Luminance Uniformity	ΔL		70	80	--	%	*1)*3)	
Response Time (White - Black)	Tr+ Tf	Point-5	--	20	30	ms	*1)*3)*5)	
Viewing Angle	Horizontal	ϕ	CR \geq 10 Point-5	120	140	--	°	*1)*2)*4)
	Vertical			θ	90	110	--	°
Color Coordinate	White	Wx Wy	Point-5	0.273 0.289	0.313 0.329	0.353 0.369	*1)*3)	*1)*3)
	Red	Rx Ry		0.544 0.299	0.584 0.339	0.624 0.379		
	Green	Gx Gy		0.275 0.528	0.315 0.568	0.355 0.608		
	Blue	Bx By		0.108 0.118	0.148 0.158	0.188 0.198		

Remarks :

*1)Measure condition : 25°C \pm 2°C , 60 \pm 10%RH , under10 Lux in the dark room.BM-5A (TOPCON) , viewing angle2° , VCC=3.3V , VLED=5V.

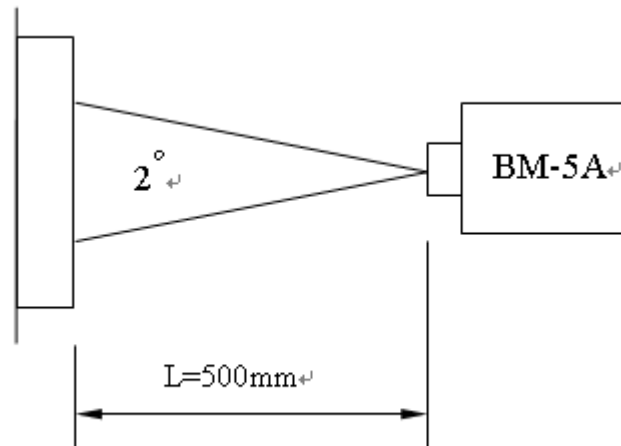

*2) Definition of contrast ratio :

$$\text{Contrast Ratio (CR)} = (\text{White}) \text{ Luminance of ON} \div (\text{Black}) \text{ Luminance of OFF}$$

*3) Definition of luminance :

Measure white luminance on the point 5 as figure8-1

Definition of Luminance Uniformity:

Measure white luminance on the point1~9as figure8-1

$$\Delta L = [L(\text{MIN})/L(\text{MAX})] \times 100$$

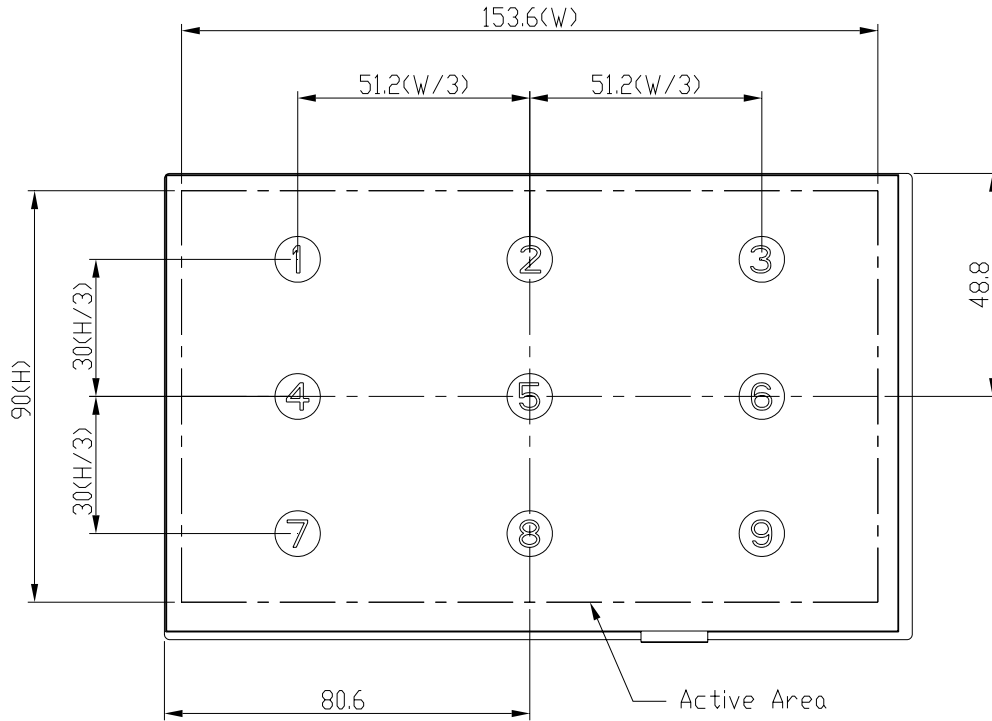

Fig8-1 Measuring point

*4) Definition of Viewing Angle(θ, ψ), refer to Fig8-2 as below :

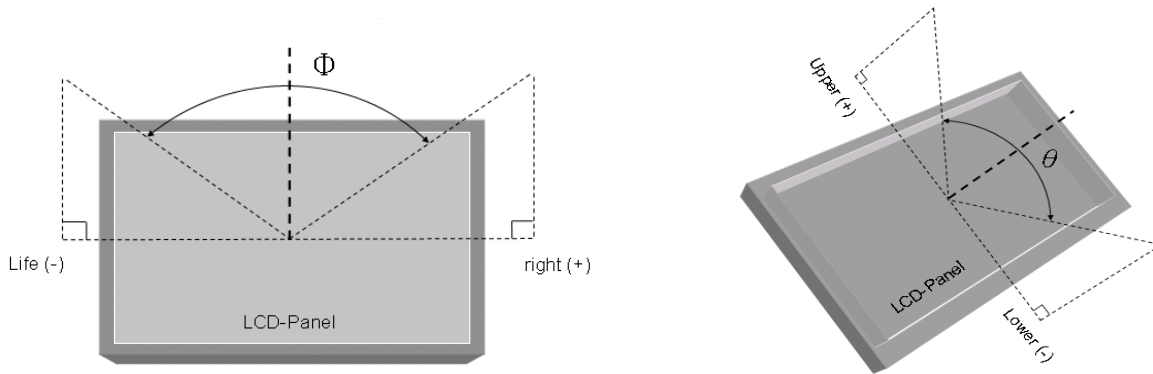

Fig8-2 Definition of Viewing Angle

*5) Definition of Response Time.(White-Black)

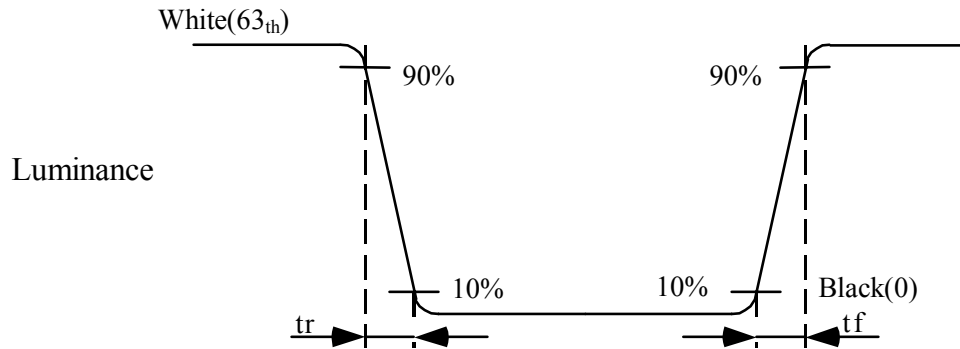

Fig9-3 Definition of Response Time(White-Black)

9. RELIABILITY TEST

9.1. Temperature and humidity

TEST ITEMS	CONDITIONS	REMARK
High Temperature Operation	85°C , 240Hrs	
High Temperature Storage	95°C , 240Hrs	
High Temperature High Humidity Operation	60°C , 90%RH , 240Hrs	No condensation
Low Temperature Operation	-30°C , 240Hrs	
Low Temperature Storage	-40°C , 240Hrs	
Thermal Shock	-30°C (0.5Hr) ~ 85°C(0.5Hr) 200 cycles	

9.2. Shock and Vibration

TEST ITEMS	CONDITIONS
Shock (Non-operation)	<ul style="list-style-type: none"> ● Shock level:980m/s²(equal to 100G) ● Waveform:half sinusoidal wave,6ms. ● Number of shocks:one shock input in each direction of three mutually perpendicular axes for a total of three shock inputs.
Vibration (Non-operation)	<ul style="list-style-type: none"> ● Frequency range:8~33.3Hz ● Stoke:1.3mm ● Vibration: sinusoidal wave, perpendicular axis(both x, z axis:2Hrs,y axis:4Hrs). ● Sweep:2.9G,33.3Hz-400Hz ● Cycle:15min

9.3 Judgment standard

The Judgment of the above test should be made as follow:

Pass:Normal display image with no obvious non-uniformity and no line defect.Partial trasformation of the module parts should be ignored.

Fail:No display image,obvious non-uniformity,or line defect.