



Chunghwa Picture Tubes, Ltd.

Product Specification

To : Data-Modul

Date : 120808

TFT LCD

CLAA070NJ01CW

ACCEPTED BY :

V 0.2

APPROVED BY	CHECKED BY	PREPARED BY
鍾昭玟	李家銘	陳威

Prepared by :

Product Planning Management Division

Consumer Electronic Business Unit

CHUNGHWA PICTURE TUBES, LTD.

1127 Hopin Rd., Padeh, Taoyuan, Taiwan 334, R.O.C.

TEL: +886-3-3675151 FAX: +886-3-377-3858

Doc.No:	SPEC_CLAA070NJ01CW_V0.2_Data-Modul_120808	Issue Date:	2012/07/23
---------	---	-------------	------------

REVISION STATUS

Revision Notice	Description	Page	Rev. Date
0.0	First revision (Tentative)	--	2012.02.22
0.1	1. Modify Power Consumption (W) 1.46 W → 2.823 W	4	2012.05.29
	2. Modify Module Weight TBD → 120 g	4	2012.05.29
	3. Modify Common Power Supply Voltage TBD → 3.9 V	6	2012.05.29
	4. Modify MECHANICAL DIMENSIONC Rear Side	14	2012.05.29
	5. Add RGB Chromacicity Red : original TBD modify x : 0.587 y : 0.340 Green : original TBD modify x : 0.343 y : 0.599 Blue : original TBD modify x : 0.158 y : 0.123	15	2012.05.29
0.2	Common Power Supply Voltage tolerance modify 0.5V to 0.2V old min:3.4V , typ:3.9V , max 4.4V , new min:3.7V , typ:3.9V , max:4.1V	6	2012.07.23

CONTENTS

1. OVERVIEW	4
2. ABSOLUTE MAXIMUM RATINGS.....	5
3. ELECTRICAL CHARACTERISTICS	6
3.1 Typical Operation Conditions	6
3.2 Current consumption.....	7
3.3 Power 、 Signal Sequence	7
3.5 Timing Sequence(Timing Chart)	8
3.5.1 Horizontal Timing Sequence	8
3.5.2 Vertical Timing Sequence	8
3.5.3 LVDS Input Data Mapping.....	9
3.6 Backlight.....	10
4. INTERFACE CONNECTION	11
4.1 CN1 (Input Signal)	11
5. MECHANICAL DIMENSIONC.....	13
5.1 Front Side	13
5.2 Rear Side.....	14
6. OPTICAL CHARACTERISTICS	15
7. RELIABILITY TEST.....	17
7.1 Temperature and Humidity	17
7.2 Shock and Vibration.....	17
7.3 Electrostatic Discharge	17
7.4 Judgment Standard.....	18
8. PACKING	18
9. WARRANTY	18

1. OVERVIEW

CLAA070NJ01CW is 7.0" color TFT-LCD (Thin Film Transistor Liquid Crystal Display) module composed of LCD panel, driver ICs, control circuit and LED backlight. By applying 1024×600 images are displayed on the 7.0" diagonal screen. Display 16.7M colors by R.G.B signal input.

General specifications are summarized in the following table :

ITEM	SPECIFICATION			
Display Area (mm)	154.2144(H) × 85.92(V)			
Number of Pixels	1024(H) × 3(RGB) × 600(V)			
Pixel Pitch (mm)	0.1506(H) × 0.1432(V)			
Color Pixel Arrangement	RGB vertical stripe			
Display Mode	Normally White			
Number of Colors	16.7M			
Viewing Direction	6 o'clock (Max. contrast ratio, Gray level inversion)			
Brightness (cd/m ²)	550nits(typ)/500nits(min)			
Response Time (ms)	25(typ.)			
NTSC	50%			
Contrast Ratio	800(typ) ; 600 (min)			
Viewing Angle (CR ≥ 10)	160degree (Horizontal.)			
	130degree (Vertical)			
Power Consumption (W)	2.823W(Typ)			
Inversion	Dot			
Interface connection	LVDS			
Module Size (mm)		Min.	Typ.	Max
	Horizontal (H)	164.6	164.9	165.2
	Vertical (V)	99.7	100	100.3
	Depth (D)	3.1	3.4	3.7
Module Weight (g)	120 (typ)			
Backlight Unit	LED			
Surface Treatment	Anti-Glare			

2. ABSOLUTE MAXIMUM RATINGS

The following are maximum values which, if exceeded, may cause faulty operation or damage to the unit.

Item	Symbol	Min.	Max.	Unit	Note
Digital Supply Voltage	DVDD DVDD_LVDS	-0.3	3.96	V	
Analog Supply Voltage	AVDD	-0.5	14.85	V	
Gate On Voltage	VGH	-0.3	40	V	
Gate Off Voltage	VGL	-20	0.3	V	
Gate On-Gate Off Voltage	VGH-VGL	12	40	V	
Signal Input Voltage	NIND0 ~ NIND3 PIND0 ~ PIND3 NINC,PINC	-0.5	5	V	
Forward Current (per LED)	I _f	-	30	mA	
Reverse Voltage (per LED)	VR	-	5	V	
Pulse Forward Current (Per LED)	I _{fp}	-	100	mA	Note 1、2
Operating Temperature	Topa	-20	70	°C	Note 3
Storage Temperature	Tstg	-30	80	°C	Note 3

Note1 : I_{fp} Conditions : Pulse Width \leq 10msec ; Duty \leq 1/10

Note2 : perating must under the condition as below drawing.

(Ambient Temperature /Allowable Forward Current) Each LED .

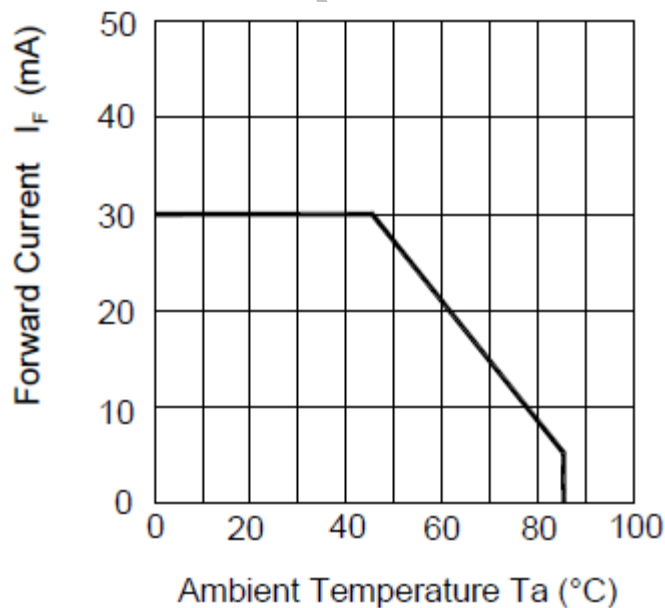

Note3 : If users use the product out off the environmmental operation range (temperature and humidity, it will have visual quality concerns.

3. ELECTRICAL CHARACTERISTICS

3.1 Typical Operation Conditions

Ta=25°C

ITEM	SYMBOL	MIN	TYP	MAX	UNIT	NOTE
Digital Power Supply Voltage For LCD	DVDD	3	3.3	3.6	V	
Logic Input Voltage (LVDS:IN+,IN-)	VCM	$\frac{ VID }{2}$	-	$2.4 - \frac{ VID }{2}$	V	Note1
	VID	200	-	600	mV	Note1
	VTH	-	-	100	mV	VCM=1.2V Note1
	VTL	-100	-	-	mV	
Analog Power Supply Voltage	AVDD	9.4	9.6	9.8	V	
Gate On Power Supply Voltage	VGH	17	18	19	V	
Gate Off Power Supply Voltage	VGL	-6.6	-6	-5.4	V	
Common Power Supply Voltage	VCOM	3.7	3.9	4.1	V	Note2
Logic Input Voltage	VIH	0.7*DVDD	-	DVDD	V	
	VIL	GND	-	0.3*DVDD	V	

【Note1】 LVDS signal

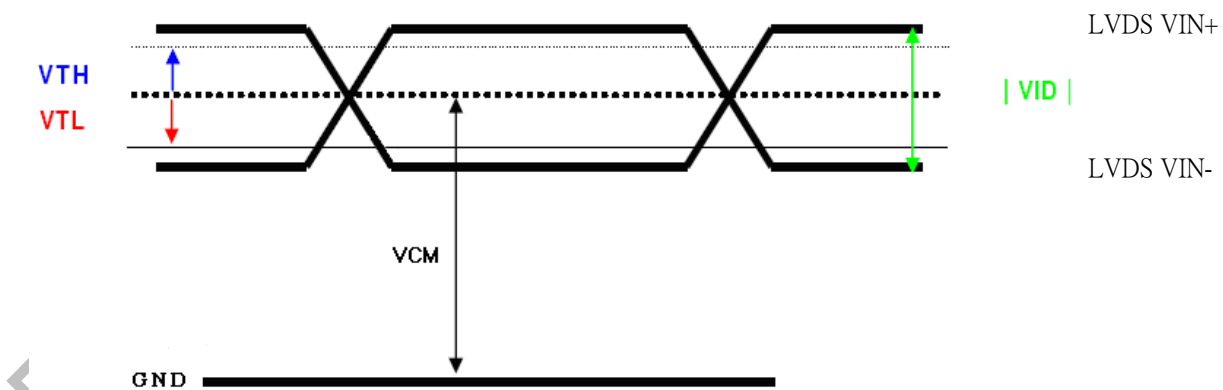

【Note2】 Please adjust VCOM to make the flicker level be minimum.

3.2 Current Consumption

ITEM	SYMBOL	CONDITION	MIN	TYPE	MAX	UNIT	NOTE
Gate On Power Current	IVGH	VGH =18V	--	0.5	1	mA	Note1
Gate Off Power Current	IVGL	VGL=-6V	--	0.5	1	mA	Note1
Digital Power Current	IDVDD	DVDD = 3.3V	--	30	45	mA	Note1
Analog Power Current	IAVDD	AVDD = 9.6V	--	35	45	mA	Note1
Total Power Consumption	PC		--	447	604	mW	Note1

【Note1】 Typ. specification : Gray-level test Pattern
 Max. specification : Black test Pattern



256 gray pattern



Black Pattern

3.3 Power · Signal Sequence

Power On : DVDD→AVDD/VGL →VGH →Video & Logic Signal→Backlight
 Power Off : Backlight→Video & Logic Signal→ VGH→AVDD/VGL→DVDD

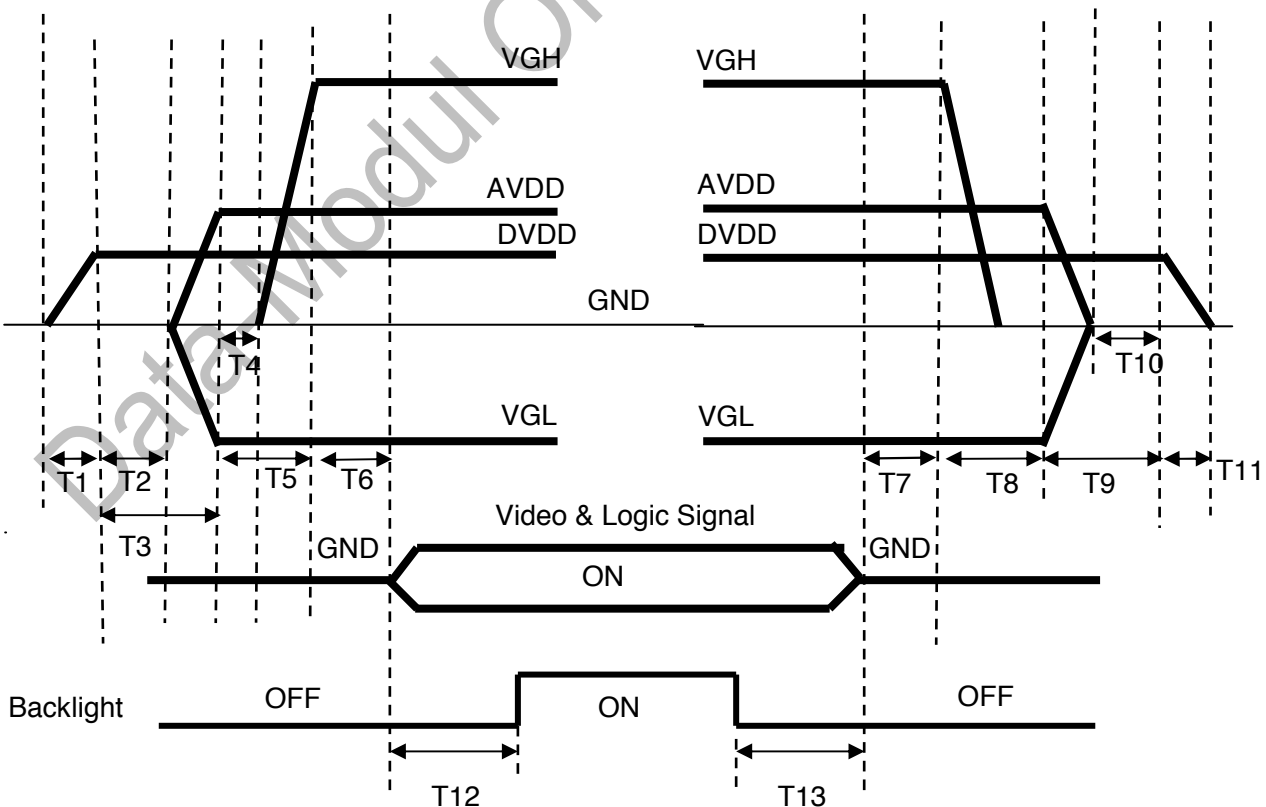

$0 < T1 \leq 10\text{ms}$
 $T2 > 0\text{ms}$
 $T3 > 20\text{ms}$
 $T4 > 0\text{ms}$
 $T5 > 10\text{ms}$
 $0 < T6 \leq 10\text{ms}$
 $T12 \geq 200\text{ms}$

$T7 > 0\text{ms}$
 $T8 > 0\text{ms}$
 $T9 > 0\text{ms}$
 $T10 > 0\text{ms}$
 $0 < T11 \leq 10\text{ms}$
 $T13 \geq 200\text{ms}$

3.4 Timing Characteristics of Input Signals

ITEM		SYMBOL	MIN	TYP	MAX	UNIT	
LVDS input signal sequence	CLK Frequency	tclk	45	51.2	57	MHz	
LCD input signal sequence (Input LVDS Transmitter)	Horizontal	Horizontal total Time	t _H	1324	1344	1364	tCLK
		Horizontal effective Time	t _{HA}	1024			tCLK
		Horizontal Blank Time	t _{HB}	300	320	340	tCLK
	Vertical	Vertical total Time	t _V	625	635	645	t _H
		Vertical effective Time	t _{VA}	600			t _H
		Vertical Blank Time	t _{VB}	25	35	45	t _H

3.5 Timing Sequence(Timing Chart)

3.5.1 Horizontal Timing Sequence

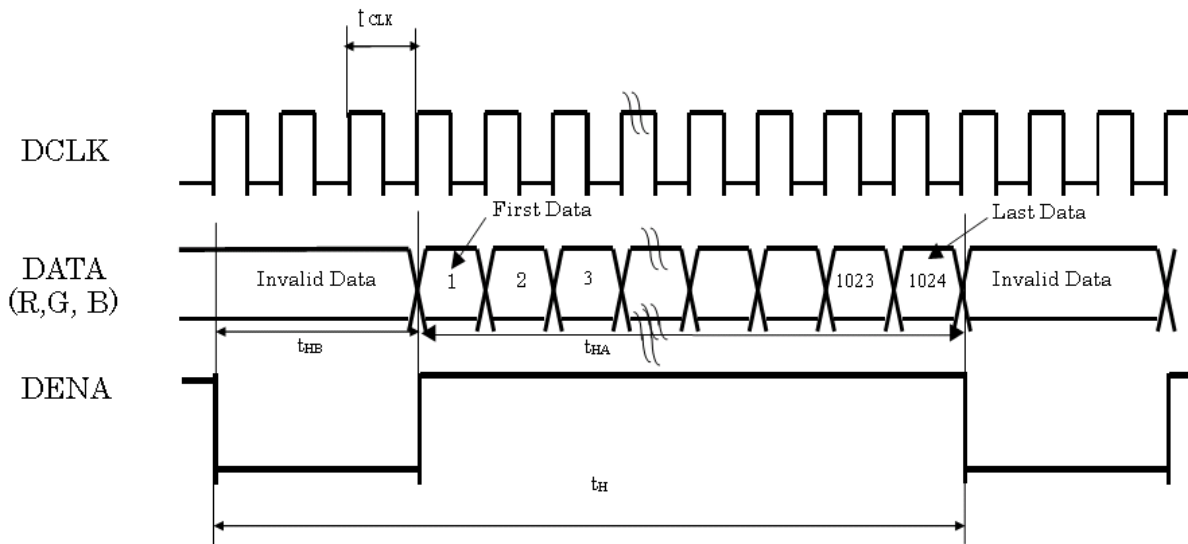

3.5.2 Vertical Timing Sequence

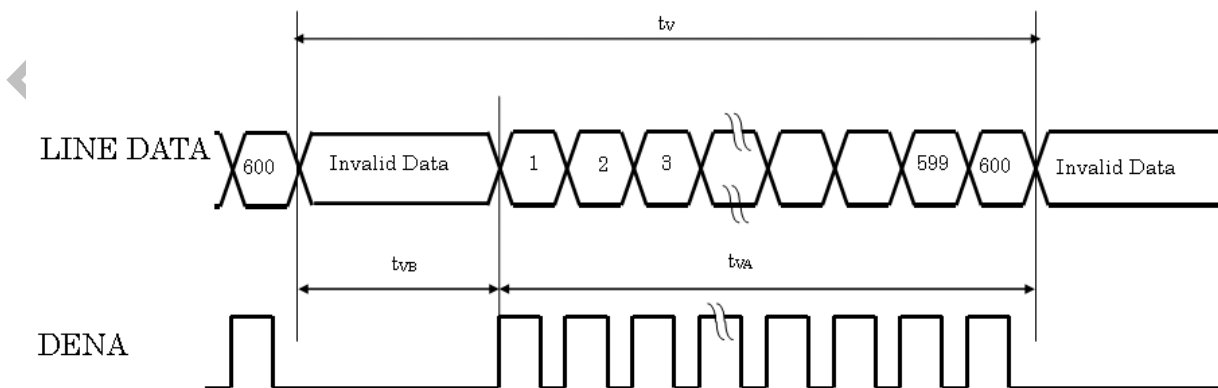

3.5.3 LVDS Input Data Mapping

6bits LVDS Input

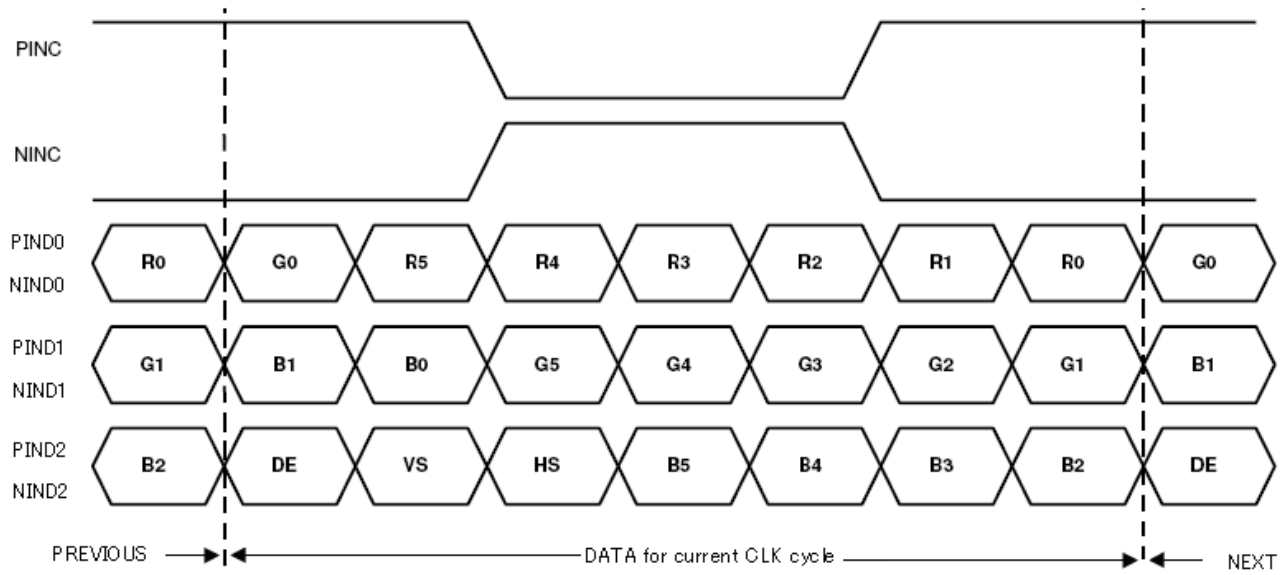

8bits LVDS Input

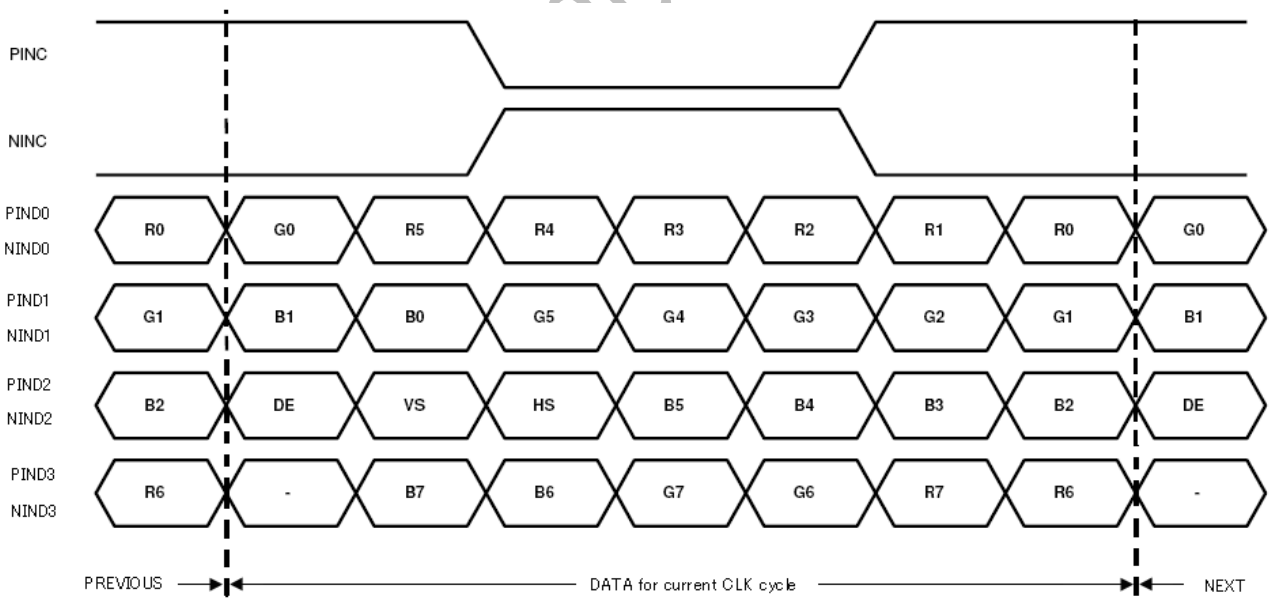

3.6 Backlight

Ta=25°C

ITEM	SYMBOL	CONDITION	MIN.	TYP.	MAX.	UNIT
LED Current	IL	Ta=25°C Each serial=20mA	-	120	-	mA
LED Voltage	VL	Ta=25°C Each serial=20mA	17.7	19.8	21.3	V
Power Consumption	WL	Ta=25°C Each serial=20mA	-	2.376	-	W
LED Lifetime	-	Ta=25°C Each serial=20mA	20000			Hr

【Note】

*1)LED Circuit Diagram :

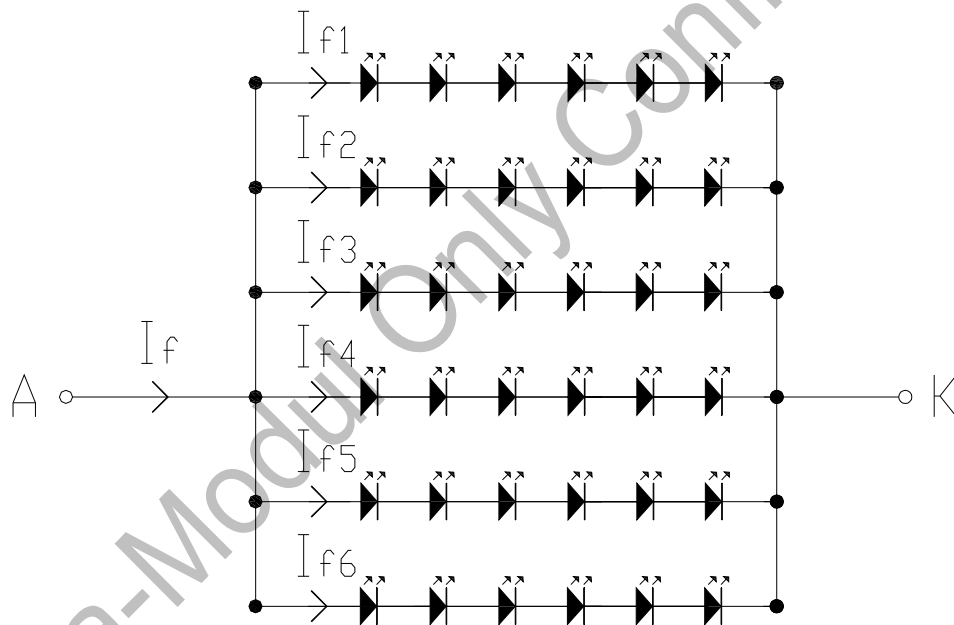

*2) A : Anode(+) , K : Cathode(-)

*3) LED control suggested fixed current.

*4) Definition of the LED life time : Luminance will decay less than 50%

4. INTERFACE CONNECTION

4.1 CN1 (Input Signal)

Pin No.	SYMBOL	FUNCTION	Remark
1	VCOM	Common Voltage	
2	DVDD	Digital Power	
3	DVDD	Digital Power	
4	NC	Not Connect	
5	RESET	Global reset pin. Active low to enter reset state. Suggest to connecting with an RC reset circuit for stability. Normally pull high. (R=10KΩ · C=0.1μF)	
6	STBYB	Standby mode, normally pull high STBYB="1", normal operation STBYB="0", timing control, source driver will turn off, all output are high-Z	
7	GND	Ground	
8	NIND0	Negative LVDS differential data input	
9	PIND0	Positive LVDS differential data input	
10	GND	Ground	
11	NIND1	Negative LVDS differential data input	
12	PIND1	Positive LVDS differential data input	
13	GND	Ground	
14	NIND2	Negative LVDS differential data input	
15	PIND2	Positive LVDS differential data input	
16	GND	Ground	
17	NINC	Negative LVDS differential clock input	
18	PINC	Positive LVDS differential clock input	
19	GND	Ground	
20	NIND3	Negative LVDS differential data input	
21	PIND3	Positive LVDS differential data input	
22	GND	Ground	
23	NC	Not Connect	
24	NC	Not Connect	
25	GND	Ground	
26	NC	Not Connect	
27	NC	Not Connect	
28	SELB	6bit/8bit Mode Select	*1)
29	AVDD	Power for Analog Circuit	
30	GND	Ground	
31	LED-	LED Cathode	
32	LED-	LED Cathode	
33	SHLR	Horizontal Inversion	*2)
34	UPDN	Vertical Inversion	*2)
35	VGL	Negative Power for TFT	
36	NC	Not Connect	
37	NC	Not Connect	
38	VGH	Positive Power for TFT	
39	LED+	LED Anode	
40	LED+	LED Anode	

Remarks :

*1)if LVDS input data is 6bits,SELB must must be set to High
if LVDS input data is 8bit , SELB must be set to Low

*2)UPDN and SHLR control function

UPDN	SHLR	FUNCTION
0	1	Normal Display
0	0	Inverse Left and Right
1	1	Inverse Up and Down
1	0	Inverse Left and Right Inverse Up and Down

SHLR	UPDN	Data shifting
DVDD	GND	Left→Right · Up→Down(default)
GND	GND	Right→Left · Up→Down
DVDD	DVDD	Left→Right · Down→Up
GND	DVDD	Right→Left · Down→Up

Definition of scanning direction.

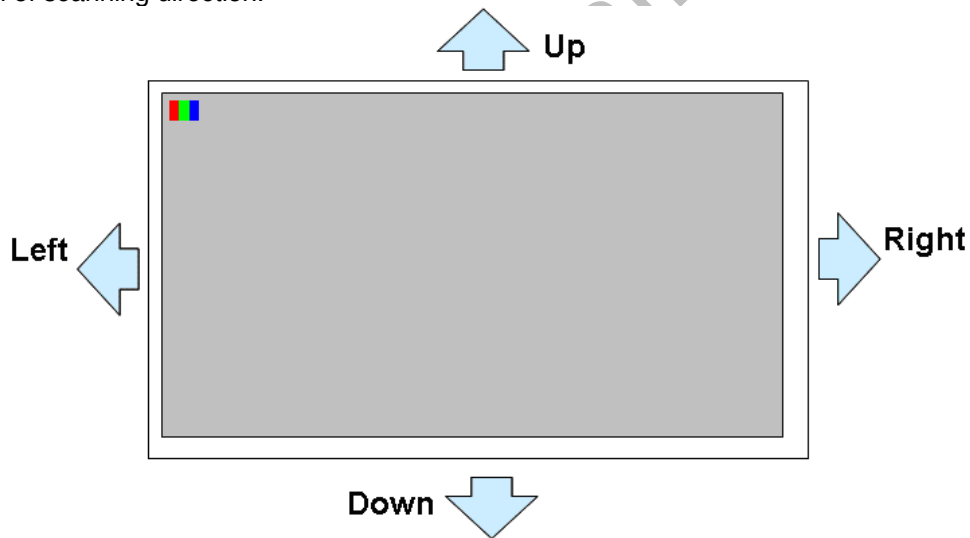

5. MECHANICAL DIMENSIONC

5.1 Front Side

(Unit : mm)

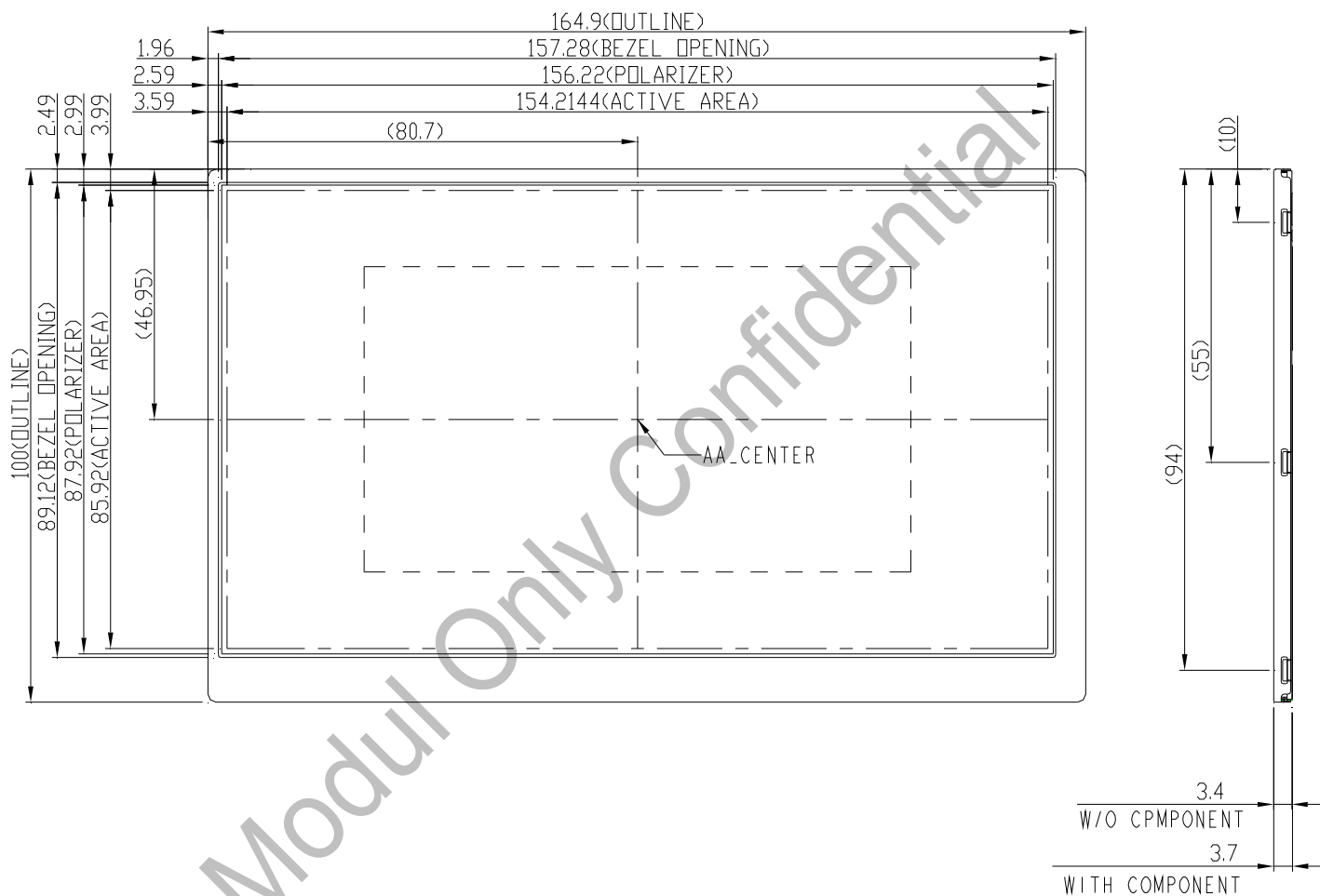

5.2 Rear Side

(Unit : mm)

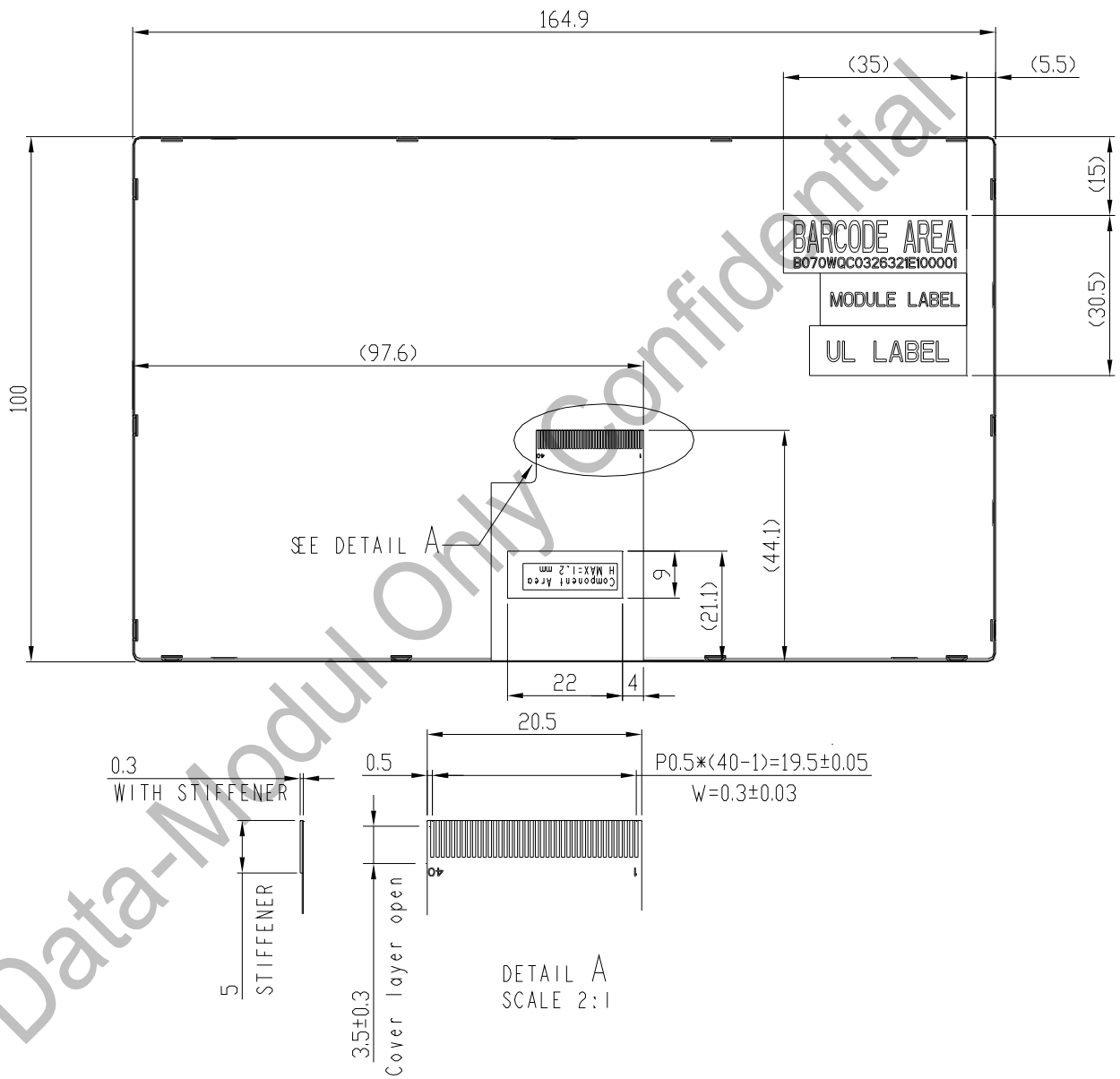

[Note] : Tolerance is ±0.3mm unless noted

6. OPTICAL CHARACTERISTICS

(Use CPT LED backlight)

Ta=25°C

ITEM	SYMBOL	CONDITION	MIN.	TYP.	MAX.	UNIT	NOTE
Contrast Ratio	CR	Point-5	600	800	--	--	2
Response Time	Tr +Tf	Point-5	--	25	40	ms	3
Luminance	L	Point-5	500	550	--	cd/m ²	
Luminance Uniformity	ΔL	*2)	70	80	--	%	
NTSC			45%	50%	--		
Viewing Angle	Left	φ	Point-5 CR ≥ 10	70	80		4
	Right	φ		70	80		4
	Upper	θ		50	60		4
	Lower	θ		60	70		4
MDL Chromacity	White	x	θ = φ = 0°	0.273	0.313	0.353	
		y		0.289	0.329	0.369	
	Red	x	θ = φ = 0°	0.547	0.587	0.627	
		y		0.300	0.340	0.380	
	Green	x	θ = φ = 0°	0.303	0.343	0.383	
		y		0.559	0.599	0.639	
	Blue	x	θ = φ = 0°	0.118	0.158	0.198	
		y		0.083	0.123	0.163	

Note1: Measure condition : 25°C ±2°C , 60±10%RH , under10 Lux in the dark room.BM-5A (TOPCON) , viewing angle2° , IL=120 mA (Backlight current) , measurement after lighting on 10 mins.

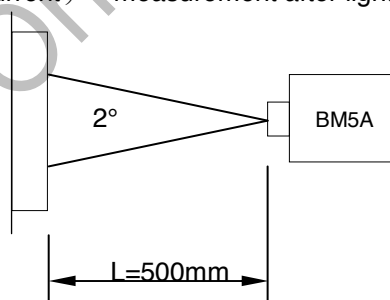

Note2: Definition of contrast ratio :

Contrast Ratio (CR)= (White) Luminance of ON ÷ (Black) Luminance of OFF

Definition of luminance : Measure white luminance on the point 5 as figure.6-1

ΔL = [L(MIN)/L(MAX)]×100

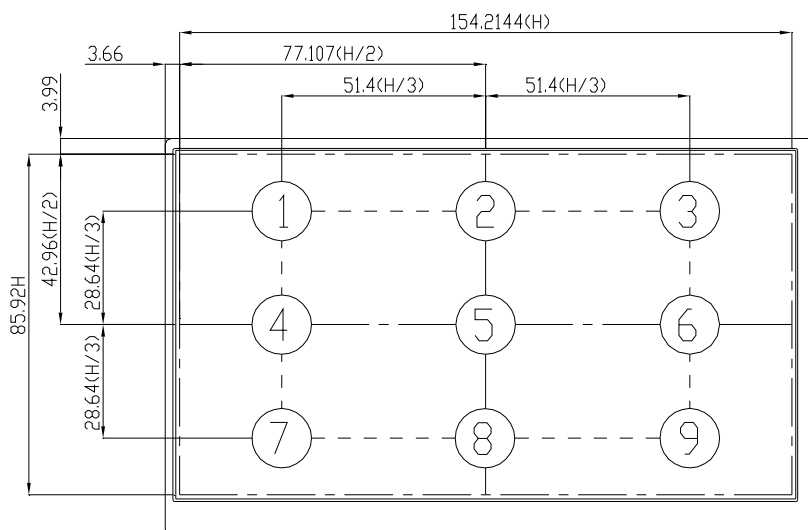

Fig. 6-1 Measuring point

Note 3: Definition of Response Time.(White-Black)

The response time is defined as the time interval between the 10% and 90% amplitudes.

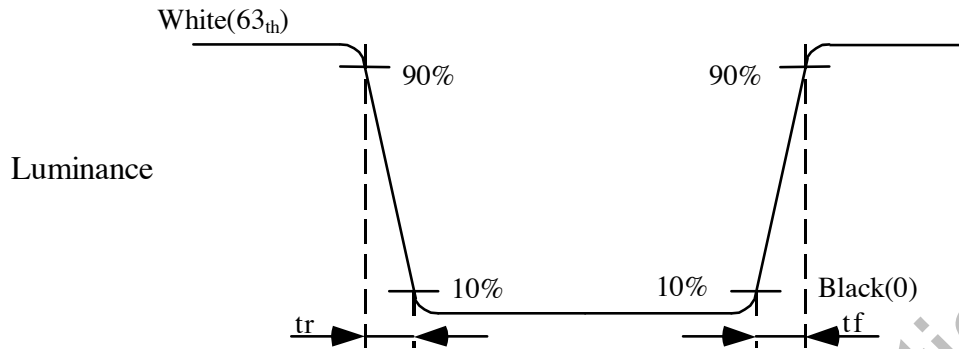

Fig. 6-2 Measuring point

Note 4: Definition of Viewing Angle(θ, ψ), refer to Fig.6 as below :

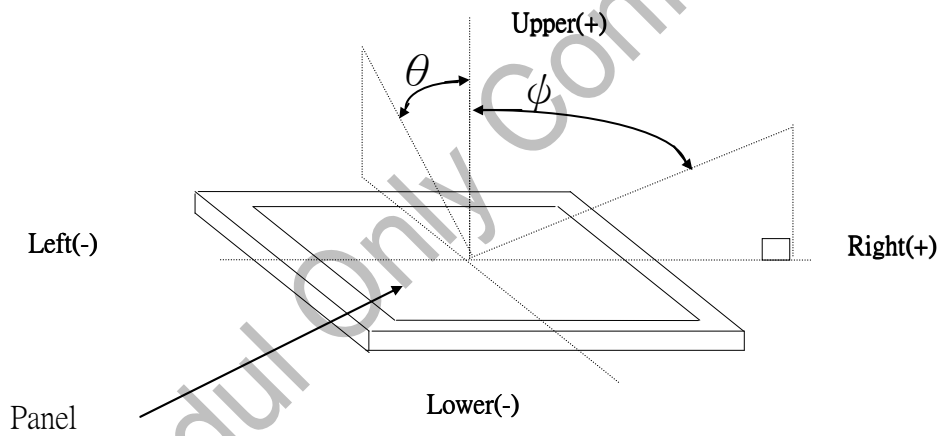

Fig.6-3 Definition of Viewing Angle

7. RELIABILITY TEST

(These tests are conducted with CPT backlight.)

7.1 Temperature and Humidity

TEST ITEMS	CONDITIONS	NOTE
High Temperature Operation	70°C ; 240hrs	
High Temperature Storage	80°C ; 240hrs	
High Temperature High Humidity Operation	60°C ; 90%RH ; 240hrs (No condensation)	
Low Temperature Operation	-20°C ; 240hrs	
Low Temperature Storage	-30°C ; 240hrs	
Thermal Shock	-30°C (0.5hr) ~ 80°C (0.5hr) ; 200 Cycles	Non-Operating
Image Sticking	25°C ; 4hrs	1
MTBF	200,00hrs	

Note 1: Condition of Image Sticking test : 25 °C ± 2 °C

Operation with test pattern sustained for 4 hrs, then change to gray pattern immediately.
After 5 mins, the mura must be disappeared completely .

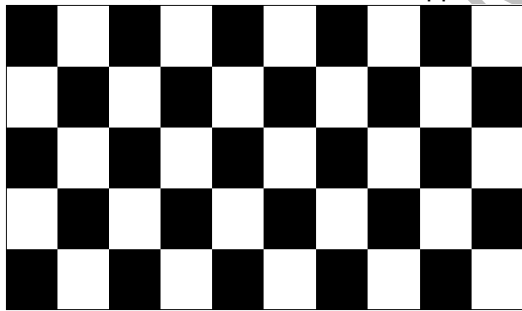

(a) Test Pattern (chess board Pattern)



(b) Gray Pattern

7.2 Shock and Vibration

ITEMS	CONDITIONS
Shock (Non-Operation)	<ul style="list-style-type: none"> ● Shock level : 980m/s²(equal to 100G). ● Waveform : 1/2 Sine wave,6msec ● ±X , ±Y , ±Z , each axis 1 times
Vibration (Non-Operation)	<ul style="list-style-type: none"> ● Frequency range : 8~33.3Hz ● Stoke : 1.3 mm ● Vibration : sinusoidal wave, perpendicular axis (both x, z axis:2Hrs, y axis 4Hrs). ● Sweep : 2.9G, 33.3 Hz -400 Hz ● Cycle : 15 min

7.3 Electrostatic Discharge

TEST ITEM	CONDITIONS	NOTE
ESD	150pF , 330Ω , ±8kV&±15kV Air& Contact test	1
	200pF , 0Ω , ±200V Contact test	2

Note: Measure point :

1. LCD glass and metal bezel
2. IF connector pins

7.4 Judgment Standard

The judgment of the above test should be made as follow:

Pass : Normal display image with no obvious non-uniformity and no line defect.

Partial transformation of the module parts should be ignored.

Fail : No display image, obvious non-uniformity, or line defects.

8. PACKING

TBD

9. WARRANTY

9.1 The period is within 12 months since the date of shipping out under normal using and storage conditions.

9.2 The warranty will be avoided in case of defect induced by customer.