



Chunghwa Picture Tubes, Ltd.

Technical Specification

To :

Date : 2012/06/25

CPT TFT-LCD
CLAA070WP03XG (MDL)

ACCEPTED BY :

APPROVED BY	CHECKED BY	PREPARED BY
Kevin Chen	Sean Lee	Product Planning Management General Division

Product Planning Management Division
Small & Medium TFT Product Business Unit
CHUNGHWA PICTURE TUBES, LTD.
1127 Hopin Rd., Padeh, Taoyuan, Taiwan 334, R.O.C.
TEL: +886-3-3675151 FAX: +886-3-377-3003

Doc. No:	CLAA070WP03XG- -SPEC-Ver.1 -20120625	Issue Date:	2012/06/25
----------	--------------------------------------	-------------	------------

1. OVERVIEW

CLAA070WP03 is 7" color TFT-LCD (Thin Film Transistor Liquid Crystal Display) module composed of LCD panel, LVDS driver ICs, control circuit and backlight. By applying 6 bit digital data, 800×RGB (3) ×1280, 262,144-color images are displayed on the 7" diagonal screen. general specifications are summarized in the following table :

ITEM	SPECIFICATION
Display Area	94.2(H)×150.72(V) (mm) (7-inch diagonal)
Number of Pixels	800 ×3(H)×1280 (V)
Pixel Pitch	0.11775(H)×0.11775(V) (mm)
Color Pixel Arrangement	RGB vertical stripe
Display Mode	Normally Black
Number of Colors	262,144(6bits)(LVDS)
Gamut	60%(Typ)
Optimum Viewing Angle	whole view
Response Time	60ms (Max)
Surface Treatment	HC , Hardness : 3H
Viewing Angle(CR>10)	85° · 85° / 85° · 85°(Min)
Brightness	450 cd/m ² (5points, average) (Typ)
Uniformity	9point : 80 %(Typ.)
Consumption of Power	0.5 (LCD Module Typical)/ 1.692 (Backlight Typical)
Module Size	161.67(H)×104.32(V)×3.85(D) (Typ.)
Module Weight	101g (Max)

The LCD Products listed on this document are not suitable for use of aerospace equipment, submarine cable, and nuclear reactor control system and life support systems. If customers intend to use these LCD products for applications listed above or those not included in the "Standard" list as follows, please contact our sales in advance.

Standard : Computer, Office equipment, Communication equipment, Test and Measurement equipment, Machine tool, Industrial robot, Audio and Visual equipment, Other consumer products.

2. ABSOLUTE MAXIMUM RATINGS

The following are maximum value, which if exceeded, may cause faulty operation or damage to the unit.

ITEM	SYMBOL	MIN.	MAX.	UNIT	NOTE
LCD Power Voltage	VDD	0	5	V	
Operation Temperature	Top	0	50	°C	*1). 2). 3). 4)
Storage Temperature	Tstg	-25	65	°C	*1). 2). 3)

【Note】

- *1) The relative temperature and humidity range are as below sketch, 90%RH Max. ($T_a \leq 40^\circ\text{C}$)
- *2) The maximum wet bulb temperature $\leq 39^\circ\text{C}$ ($T_a > 40^\circ\text{C}$) and without dewing.
- *3) If product in environment which over the definition of the relative temperature and humidity out of range too long, it will affect visual of LCD.
- *4) If you operate LCD in normal temperature range, the center surface of panel should be under 50°C .

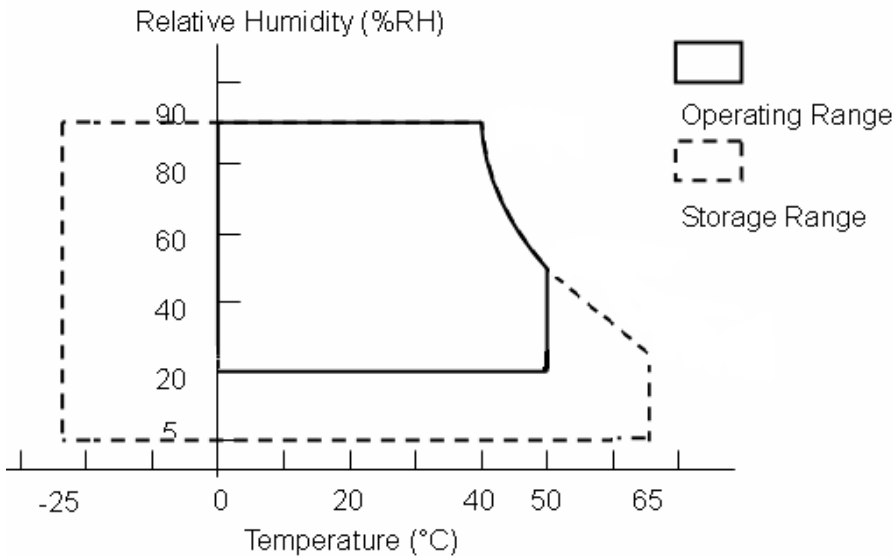

3. ELECTRICAL CHARACTERISTICS

(A) TFT LCD

TEM	SYMBOL	MIN	TYP	MAX	UNIT	NOTE
LCD Power Voltage	VDD	3	3.3	3.6	V	*1)
LCD Power Current	IDD	-	-	-	mA	*2)
Rush Current	Irush	-	-	2	A	*4)

【Note】

*1) Power Sequence :

$0.5 \text{ ms} \leq t1 \leq 10\text{ms}$

$0.01 \text{ ms} < t2 \leq 50 \text{ ms}$

$0.01 \text{ ms} < t3 \leq 50 \text{ ms}$

$500 \text{ ms} \leq t4$

$200 \text{ ms} \leq t5$

$200 \text{ ms} \leq t6$

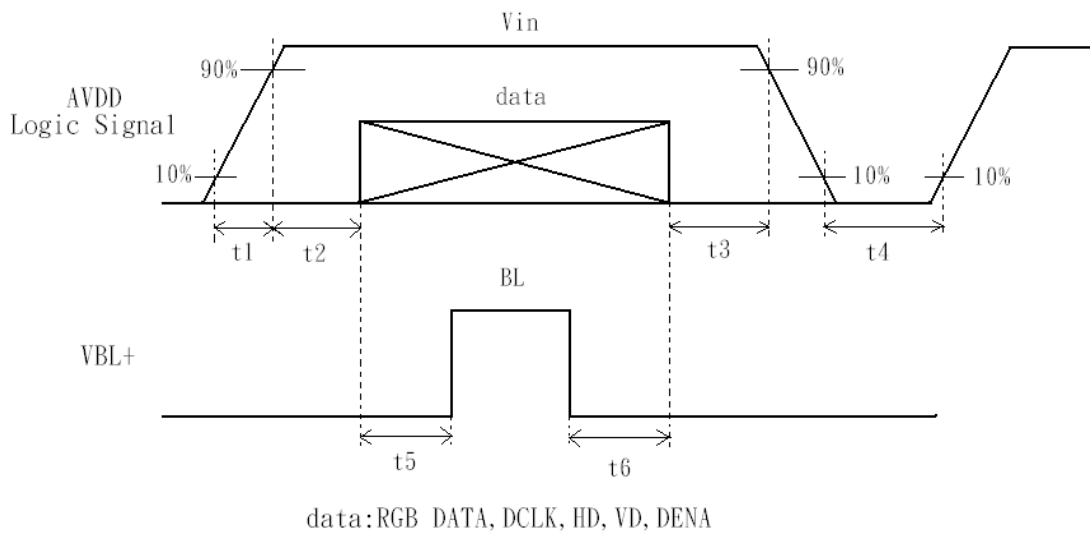

Vin-dip state

(1)when $3.0V > Vin \geq 2.7V$, $t_d \leq 10 \text{ ms}$.

(2)when $Vin < 2.7V$, Vin-dip condition should as the Vin-turn-off condition.

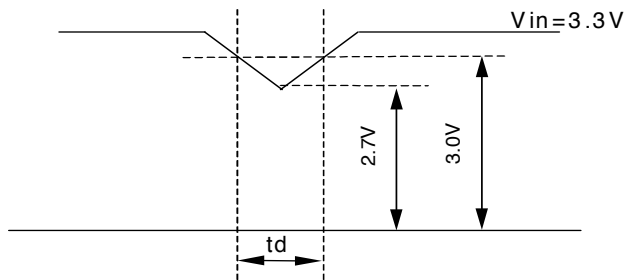

*2) Max value is White Pattern : 1280 line mode ◦

Circuit condition (Max.) : VDD=3.3 V , $f_v=60$ Hz , $f_H=51.84$ kHz , $f_{CLK}=66.77$ MHz



*3) LVDS Signal Definite :

LVDS Interface DC characteristic						
(VDD=3.0 to 3.6V, AVDD=8.0 to 13.5V, GND=AGND=0V, TA=-20 to +85°C)						
Parameter	Symbol	Min.	Typ.	Max.	Unit	Condition
Differential input high threshold voltage	R _{xVTH}			+0.2	V	R _{xVCM} =1.2V
Differential input low threshold voltage	R _{xVTL}	-0.2			V	
Input voltage range(singled-end)	R _{xVIN}	0.7	-	1.7	V	
Differential input common mode voltage	R _{xVCOM}	1	1.2	1.4	V	V _{ID} =0.2V
Differential input impedance	Z _{ID}	80	100	125	ohm	
Differential input voltage	V _{ID}	0.2	-	0.6	V	

Single-end Signals

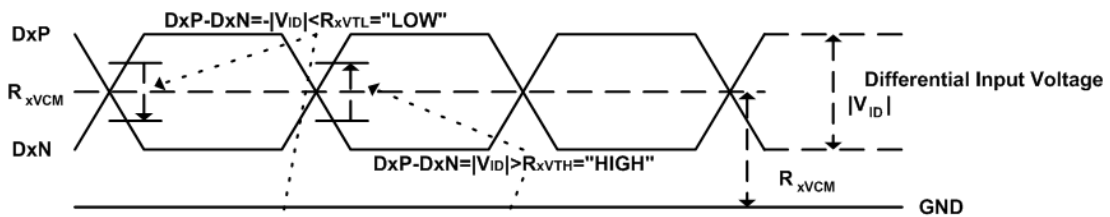

Differential Signal

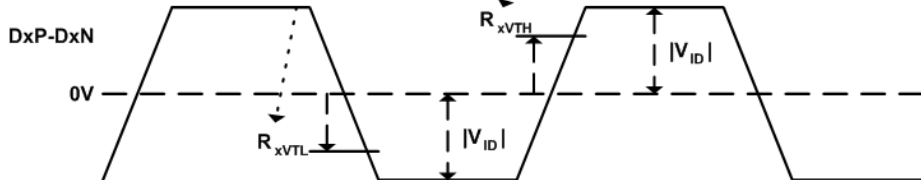

Figure1. LVDS DC Diagram

LVDS Interface AC characteristic						
(VDD=3.0 to 3.6V, AVDD=8.0 to 13.5V, GND=AGND=0V, TA=-20 to +85°C)						
Parameter	Symbol	Min.	Typ.	Max.	Unit	Condition
Clock frequency	RxFCLK		66.77		MHz	Refer to input timing table for each display resolution.
Input data skew margin	TRSKM	500	-	-	ps	VID =200mV RxVCM=1.2V RxFCLK=81MHz
Clock high time	TLVCH	-	$4/(7 * RxFCLK)$	-	ns	
Clock low time	TLCVL	-	$3/(7 * RxFCLK)$	-	ns	
PLL wake-up time	TenPLL	-	-	150	us	

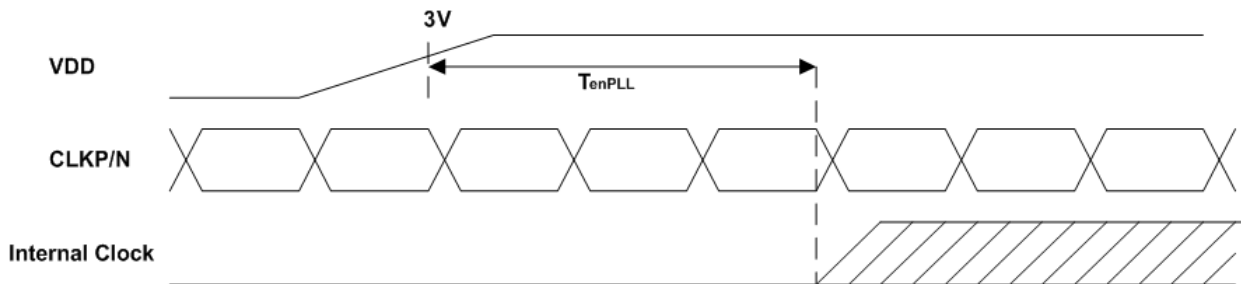

Figure2. Relationship between VDD, LVDS clock, and internal clock

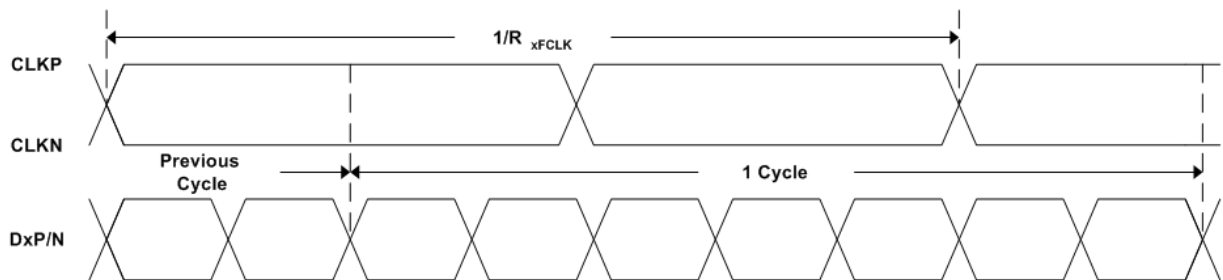
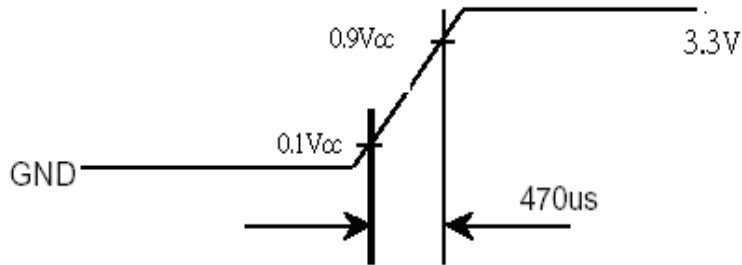
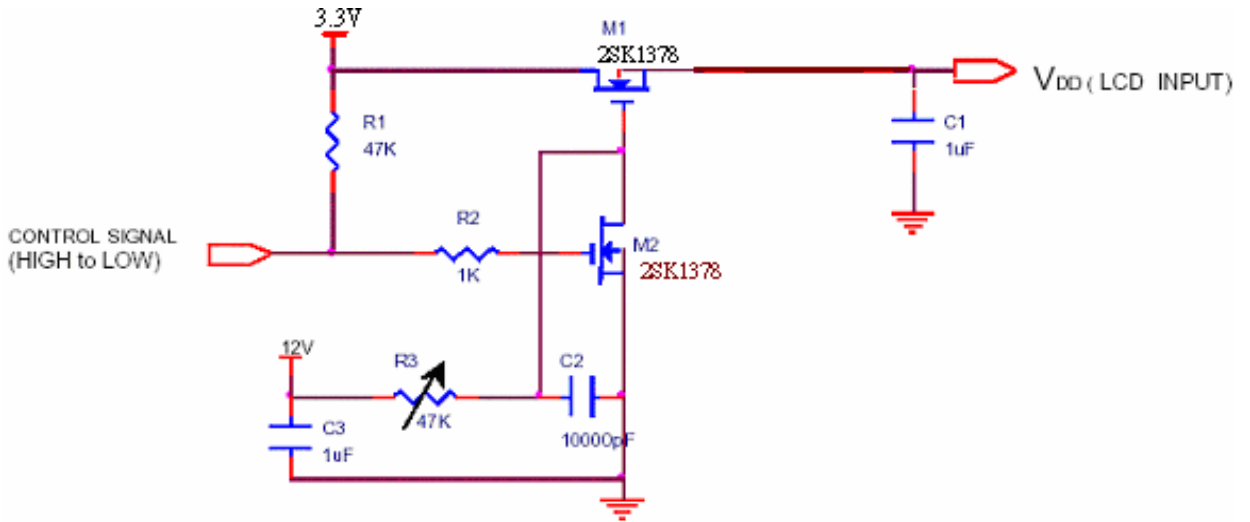

Figure3. 1 cycle time of LVDS

*4) Irush measure condition



(B) BACK LIGHT

(a.) ELECTRICAL CHARACTERISTICS

Ta=25°C

ITEM	SYMBOL	MIN	TYP	MAX	UNIT	NOTE
LED Driver Input Voltage	VBL+	3.0	3.3	5.0	V	
LED Driver Input Current	IBL+	-	512	-	mA	*1)
Forward Voltage	VF		2.85	3	V	*2)I _f =19mA
Forward Current	I _F	-	19	-	mA	
Power consumption	PLED	-	1.692		W	*2)*3)I _f =19mA
PWM Frequency	PWM_BL	180	200	220	Hz	
Duty ratio	Dim	5		100	%	

(b) LED LIFE - TIME

ITEM	Condition	min	typ	max	UNIT	NOTE
LIFE TIME	I _F =20mA · Ta=25°C	10000	x	x	hrs	*4)

(c) LED ON/OFF Sequence :

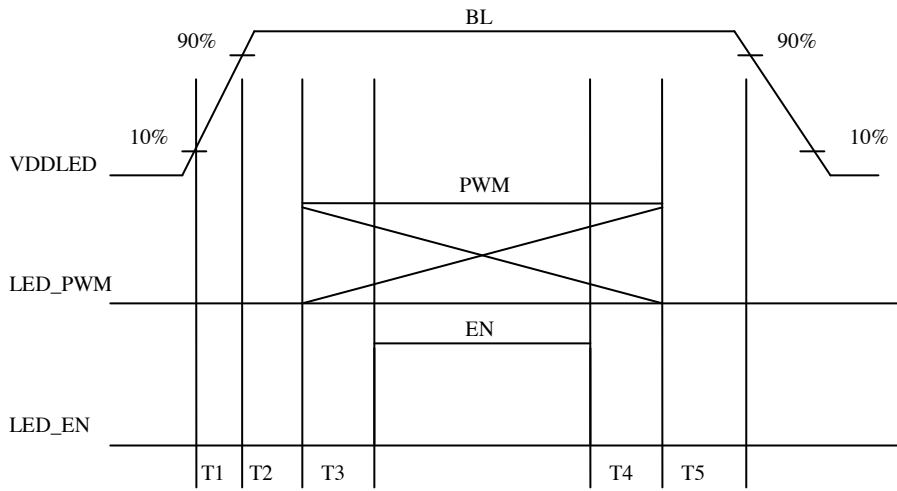

- $0.5ms \leq T1 \leq 10ms$
- $10ms \leq T2$
- $10ms \leq T3$
- $0ms \leq T4$
- $10ms \leq T5$

- *1) Maximum LED Driver Input Current at 3 V Input Voltage/PWM Duty 100%.
- *2) Measure method : a. LED current is measured by utilizing a current meter as show below.
b. System power PLED is measured at input voltage 3.3V

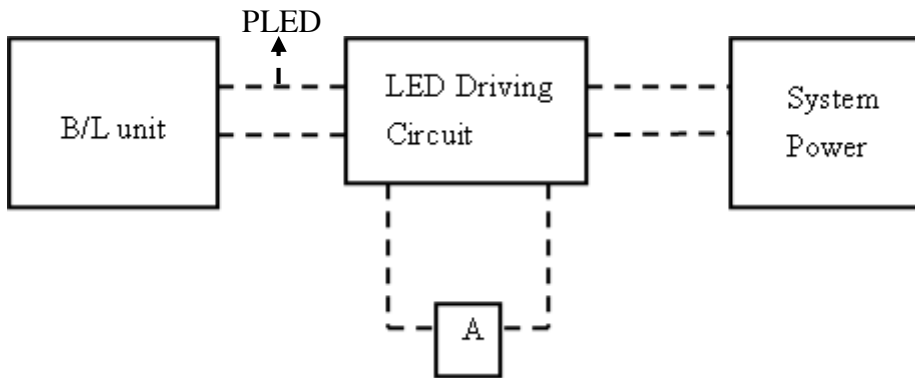

- *3) Calculator value for reference $I_F \times V_F \times N = PLED$
- *4) Life time means that estimated time to 50% degradation of initial luminous intensity.

4. Connector Interface PIN & Function

CN(Interface signal)

1	VDD	Power Supply, 3.3V typ
2	VDD	Power Supply, 3.3V typ
3	VDD	Power Supply, 3.3V typ
4	NC	NC
5	GND	Ground
6	RXINO-	D0-
7	RXINO+	D0+
8	GND	Ground
9	RXINO1-	D1-
10	RXINO1+	D1+
11	GND	Ground
12	RXINO2-	D2-
13	RXINO2+	D2+
14	GND	Ground
15	RXCLKIN-	CLK-
16	RXCLKIN+	CLK+
17	GND	Ground
18	NC	NC
19	NC	NC
20	GND	Ground
21	LVBIT	GND (6 or 8bit Change)
22	DITHER	GND (FRC)
23	GND	Ground
24	LED EN (PWM)	PWM
25	LVFMT	GND (MSB/LSB Changge)
26	BIST	NC
27	VLED	LED Power Supply , 3~5V
28	VLED	LED Power Supply , 3~5V
29	VLED	LED Power Supply , 3~5V
30	VLED	LED Power Supply , 3~5V
31	NC	NC

5. INTERFACE TIMING CHART

(1)(a). LVDS input time sequence

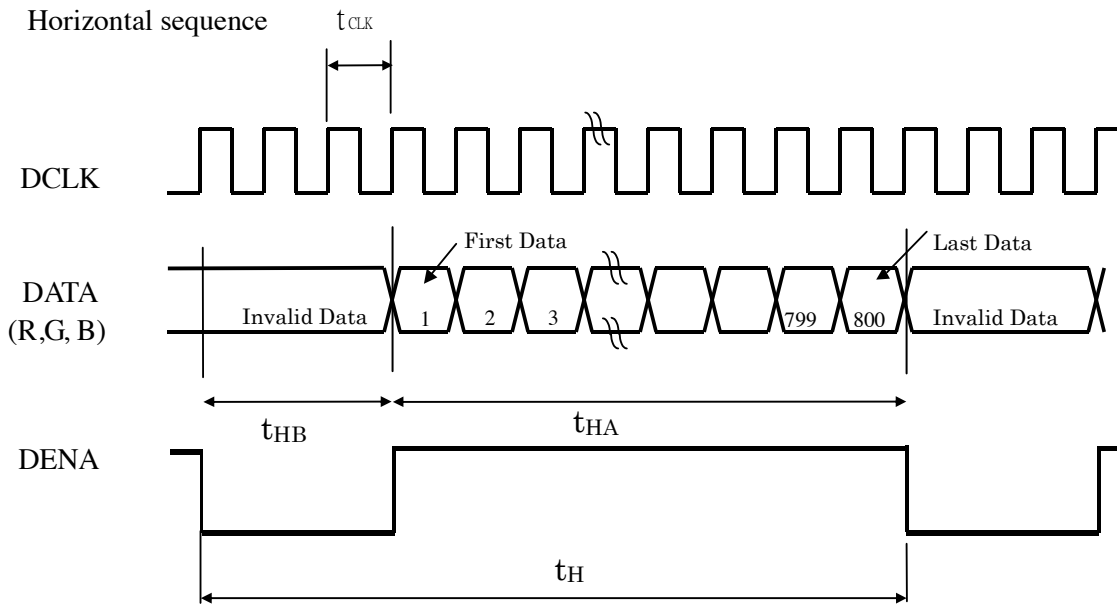

(b) LCD input time sequence

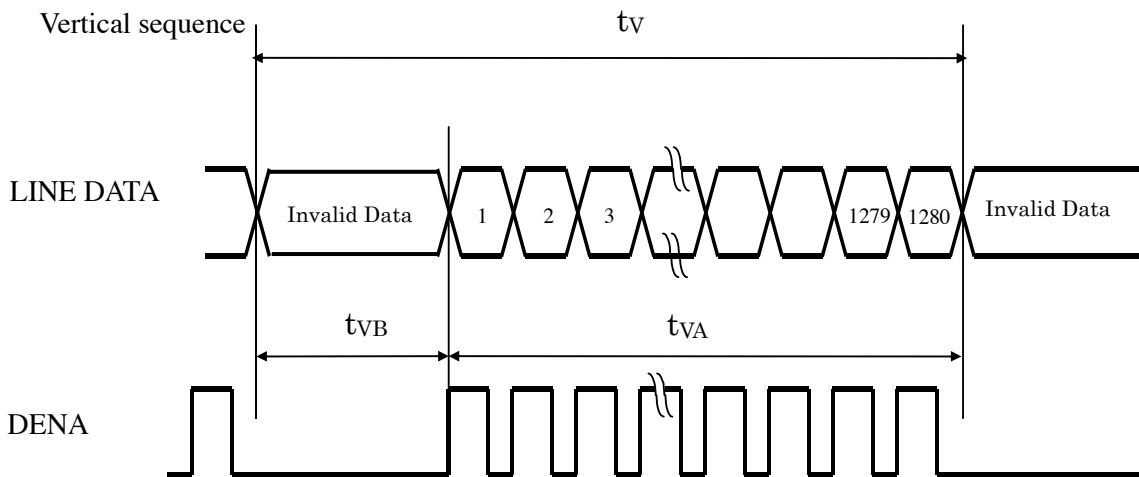

(2) Timing Chart

ITEM			SYMBOL	MIN	TYP	MAX	UNIT	
LCD Timing	Frame Rate		-	TBD	60	TBD	Hz	
	DCLK	Frequency	f _{CLK}	TBD	66.77	TBD	MHz	
	DENA	Horizontal	Horizontal total time	t _H	TBD	864	TBD	t _{CLK}
			Horizontal Active time	t _{HA}	TBD	800	TBD	t _{CLK}
			Horizontal Blank time	t _{HB}	TBD	64	TBD	t _{CLK}
	Vertical	Vertical	Vertical total time	t _V	TBD	1288	TBD	t _H
			Vertical Active time	t _{VA}	TBD	1200	TBD	t _H
			Vertical Blank time	t _{VB}	TBD	8	TBD	t _H

【Note】

*1) DENA (DATA ENABLE) usually is positive.

*2) During the whole blank period, DCLK should keep input.

(3) DATA mapping

Color	Input Data	R DATA						G DATA						B DATA					
		R5	R4	R3	R2	R1	R0	G5	G4	G3	G2	G1	G0	B5	B4	B3	B2	B1	B0
		MS B					LSB	MS B					LSB	MS B					LSB
Basic Color	Black	0	0	0	0	0	0	0	0	0	0	0	0	0	0	0	0	0	0
	Red(63)	1	1	1	1	1	1	0	0	0	0	0	0	0	0	0	0	0	0
	Green(63)	0	0	0	0	0	0	1	1	1	1	1	1	0	0	0	0	0	0
	Blue(63)	0	0	0	0	0	0	0	0	0	0	0	0	1	1	1	1	1	1
	Cyan	0	0	0	0	0	0	1	1	1	1	1	1	1	1	1	1	1	1
	Magenta	1	1	1	1	1	1	0	0	0	0	0	0	1	1	1	1	1	1
	Yellow	1	1	1	1	1	1	1	1	1	1	1	1	0	0	0	0	0	0
	White	1	1	1	1	1	1	1	1	1	1	1	1	1	1	1	1	1	1
RED	RED(0)	0	0	0	0	0	0	0	0	0	0	0	0	0	0	0	0	0	0
	RED(1)	0	0	0	0	0	1	0	0	0	0	0	0	0	0	0	0	0	0
	RED(2)	0	0	0	0	1	0	0	0	0	0	0	0	0	0	0	0	0	0
	RED(62)	1	1	1	1	1	0	0	0	0	0	0	0	0	0	0	0	0	0
	RED(63)	1	1	1	1	1	1	0	0	0	0	0	0	0	0	0	0	0	0
	Green	Green(0)	0	0	0	0	0	0	0	0	0	0	0	0	0	0	0	0	0
Green(1)		0	0	0	0	0	0	0	0	0	0	0	1	0	0	0	0	0	0
Green(2)		0	0	0	0	0	0	0	0	0	0	1	0	0	0	0	0	0	0
Green(62)		0	0	0	0	0	0	1	1	1	1	1	0	0	0	0	0	0	0
Green(63)		0	0	0	0	0	0	1	1	1	1	1	1	0	0	0	0	0	0
Blue		Blue(0)	0	0	0	0	0	0	0	0	0	0	0	0	0	0	0	0	0
	Blue(1)	0	0	0	0	0	0	0	0	0	0	0	0	0	0	0	0	0	1
	Blue(2)	0	0	0	0	0	0	0	0	0	0	0	0	0	0	0	0	1	0
	Blue(62)	0	0	0	0	0	0	0	0	0	0	0	0	1	1	1	1	1	0
	Blue(63)	0	0	0	0	0	0	0	0	0	0	0	0	1	1	1	1	1	1

【Note】

1) Gray level:

Color(n) : n is level order; higher n means brighter level.

2) DATA:

1: high , 0: low

6. BLOCK DIAGRAM

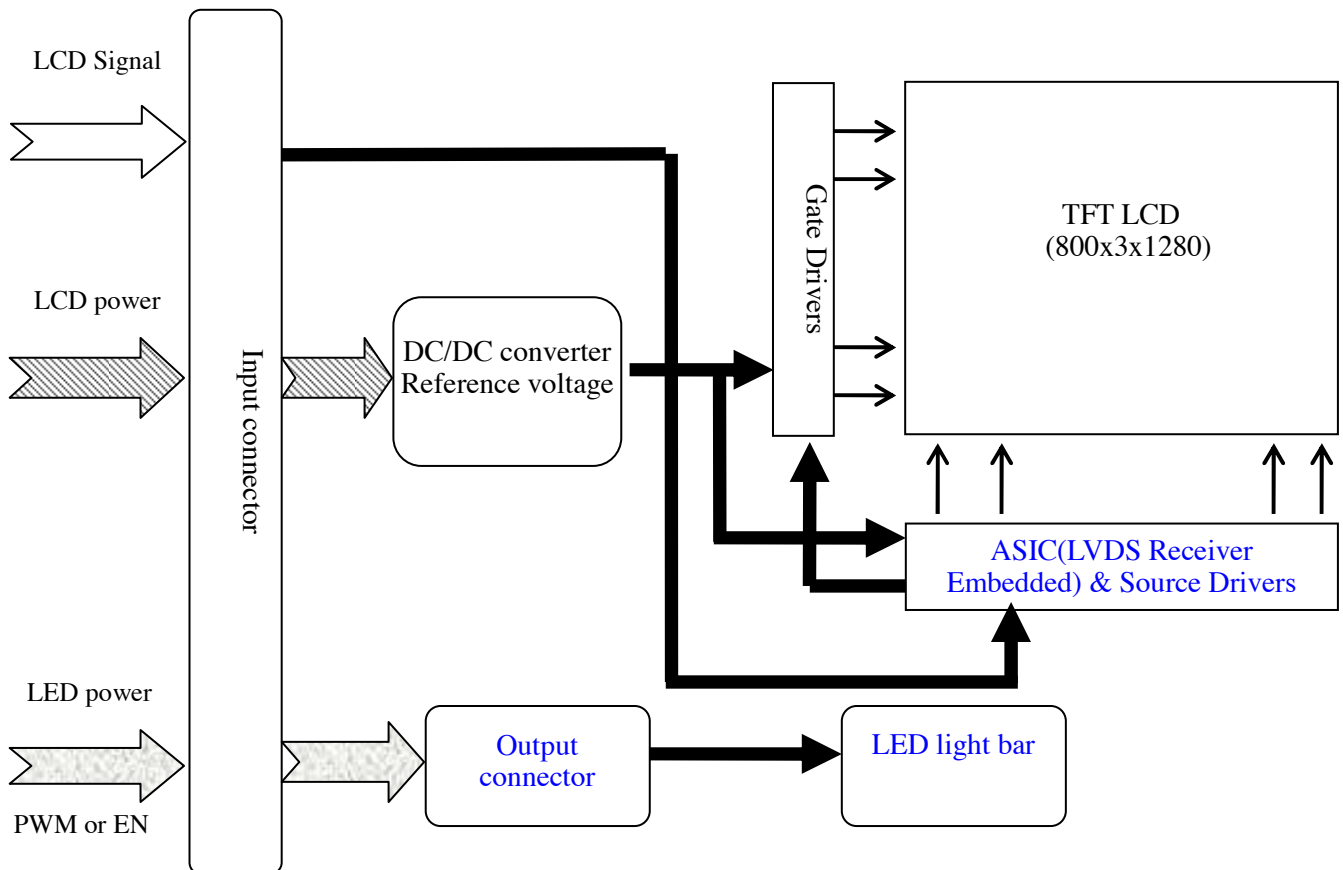

7. MECHANICAL SPECIFICATION

(1) Front side

The tolerance, not show in the figure, is $\pm 0.2\text{mm}$.

[Unit : mm]

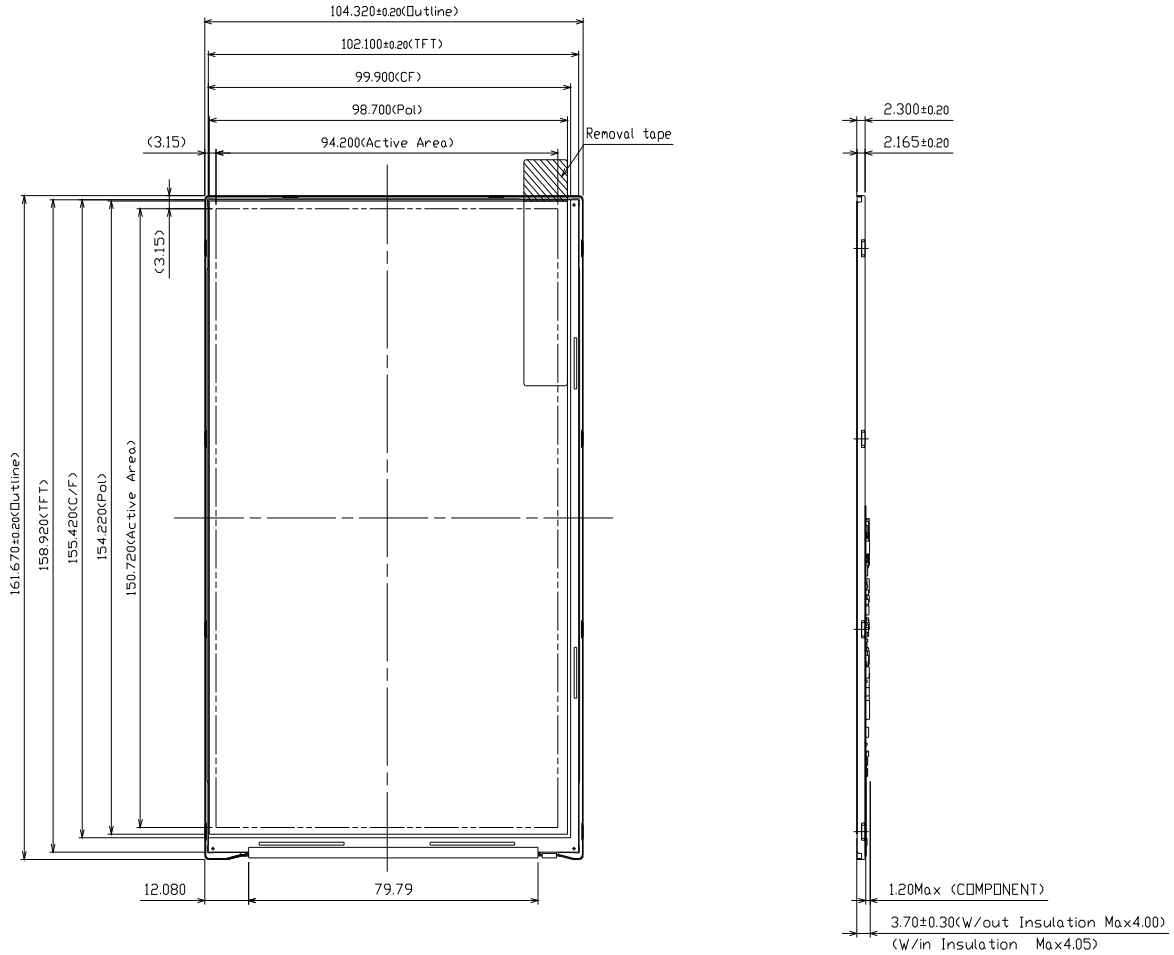

2) Rear side

The tolerance, not show in the figure, is $\pm 0.2\text{mm}$.

[Unit : mm]

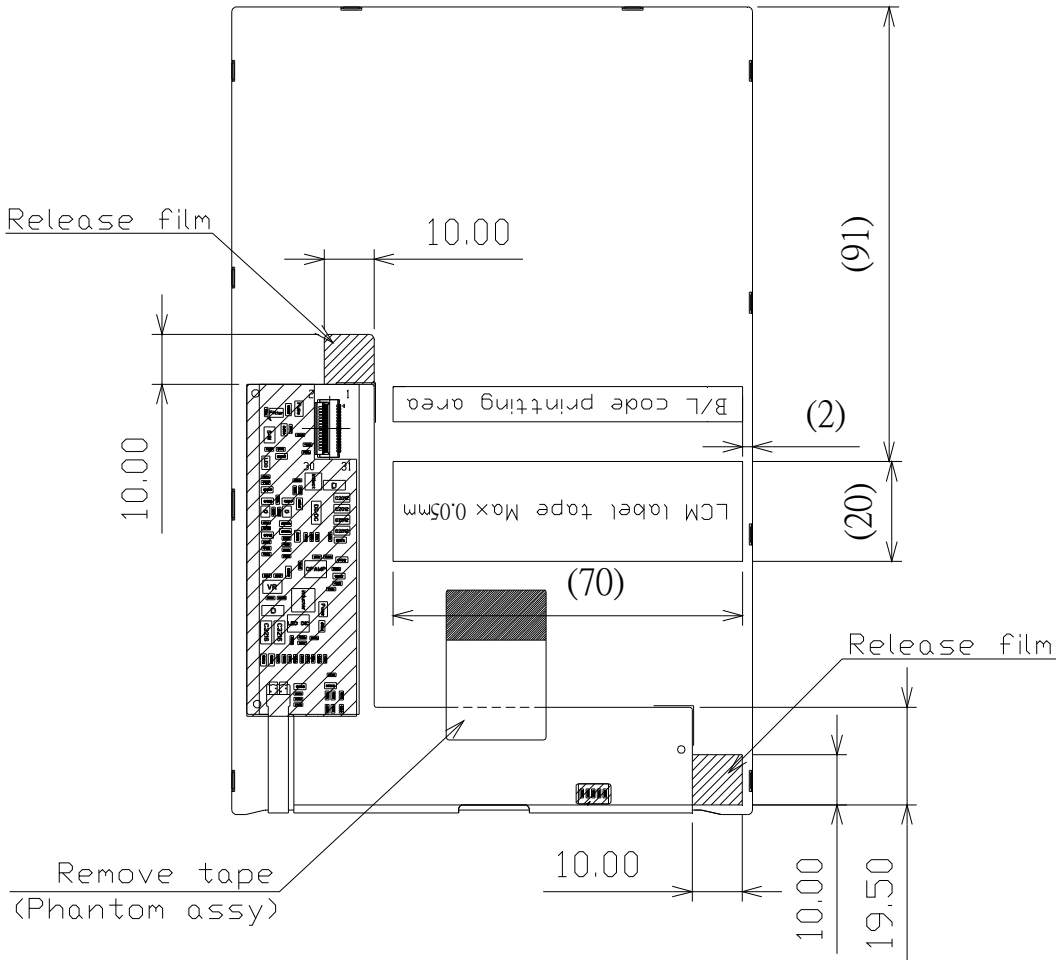

For Optical Bonding Maker
Rear view (Reference dimension)

8. OPTICAL CHARACTERISTICS

Ta=25°C , VDD=3.3V

ITEM		SYMBOL	CONDITION	MIN.	TYP.	MAX.	UNIT	NOTE
Contrast Ratio		CR	$\theta = \phi = 0^\circ$	500	700	--	--	*1) 2)
Luminance (5P Average)		L	$\theta = \phi = 0^\circ$	300	450	--	cd/m ²	*1) 3)
Uniformity(9P)		ΔL	$\theta = \phi = 0^\circ$	72	80	--	%	*1) 3)
Response Time		Tr+Tf	$\theta = \phi = 0^\circ$	--	30	60	ms	*5)
Cross talk		CT	$\theta = \phi = 0^\circ$	--	--	2.5	%	*6)
View angle	Horizontal	Ψ	$CR \geq 10$	80/-80	85/-85	--	°	View angle
	Vertical	θ		80/-80	85/-85	--	°	
Color Temperature Coordinate	W	X	$\theta = \phi = 0^\circ$	0.28	0.310	0.340	--	Color Temperature Coordinate
		Y		0.30	0.330	0.360		
	R	X		TBD	TBD	TBD	--	
		Y		TBD	TBD	TBD		
	G	X		TBD	TBD	TBD	--	
		Y		TBD	TBD	TBD		
	B	X		TBD	TBD	TBD	--	
Y		TBD	TBD	TBD				
Gamut			$\theta = \phi = 0^\circ$	--	60	--	%	
Gamma		γ	GL	2.0	2.2	2.4	--	*7)

Color coordinate and color gamut are measured by SRUL1R, response time is measured by TRD-100, and all the other items are measured by BM-5A (TOPCON). All these items are measured under the dark room condition (no ambient light).

Measurement Condition: IL=19 mA(each LED)

Definition of these measurement items is as follows:

***1) Setup of Measurement Equipment**

The LCD module should be turn-on to a stable luminance level to be reached. The measurement should be executed after lighting Backlight for 20 minutes and in a dark room.

***2) Definition of Contrast Ratio**

CR=ON (White) Luminance/OFF (Black) Luminance

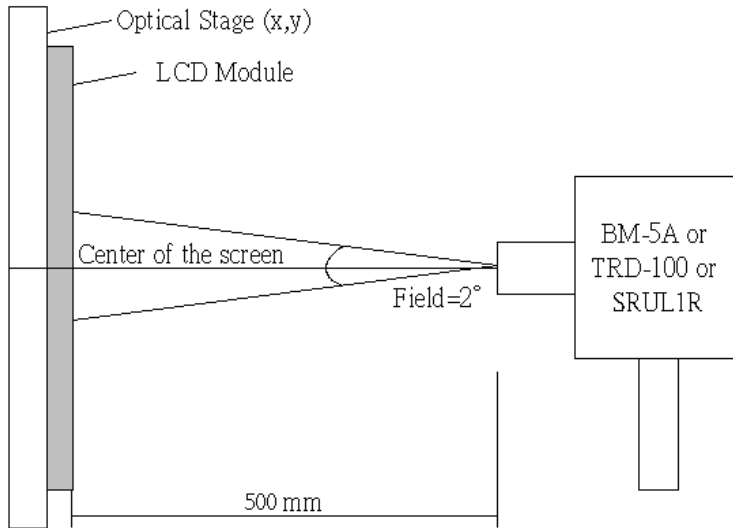

***3) Definition of Luminance and Luminance uniformity**

Central luminance: The white luminance is measured at the center position “1” on the screen, see Fig below.

5P Luminance (AVG): The white luminance is measured at measuring points 1~5 see Fig below.

9P Uniformity: $\Delta L = (L_{min} / L_{max}) \times 100\%$ at measuring points 1 & 6~13 see fig below.

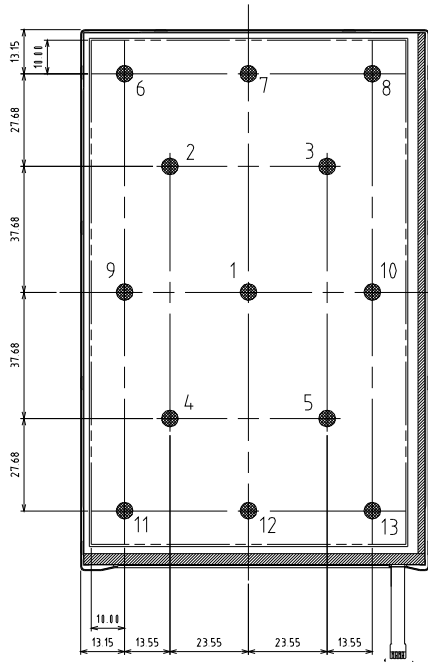

*4) Definition of view angle(θ , ψ)

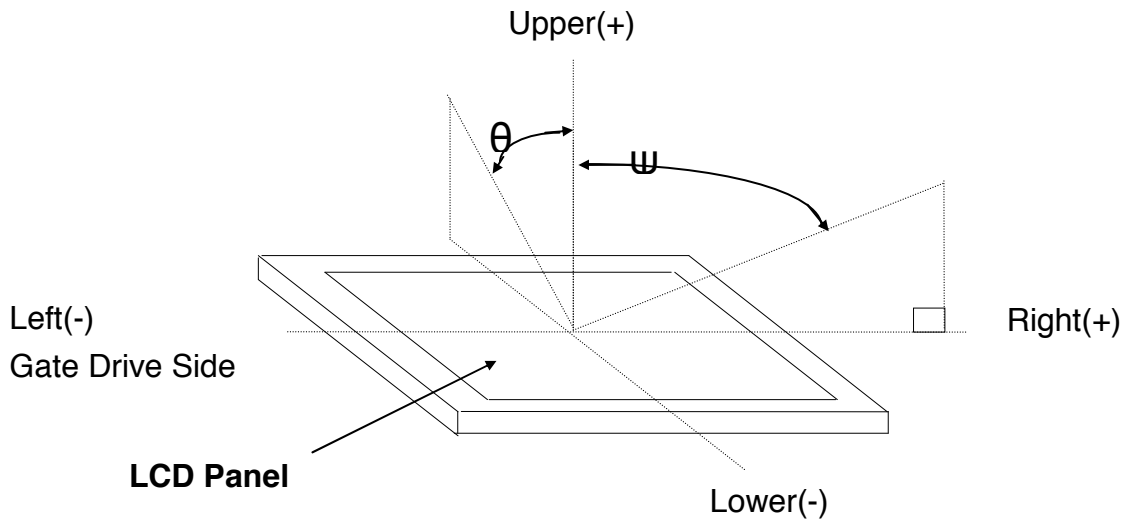

*5) Definition of response time

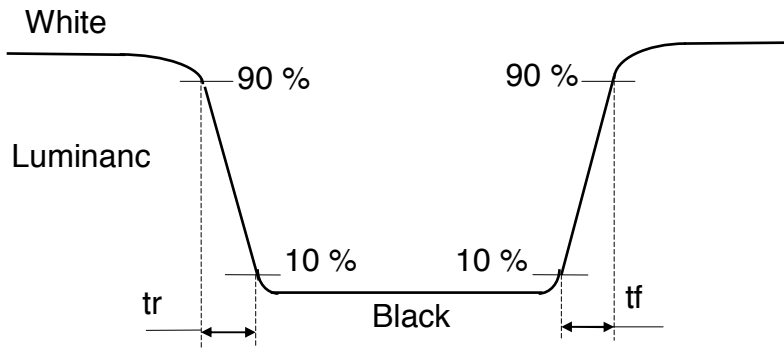

*6) Crosstalk Modulation Ratio:

$$CT = | Y_B - Y_A | / Y_{Ax} \times 100\%$$

Y_A , Y_B measure position and definition

Y_A means luminance at gray level 31(exclude gray level 0 pattern)

Y_B means luminance at gray level 31(include gray level 0 pattern)

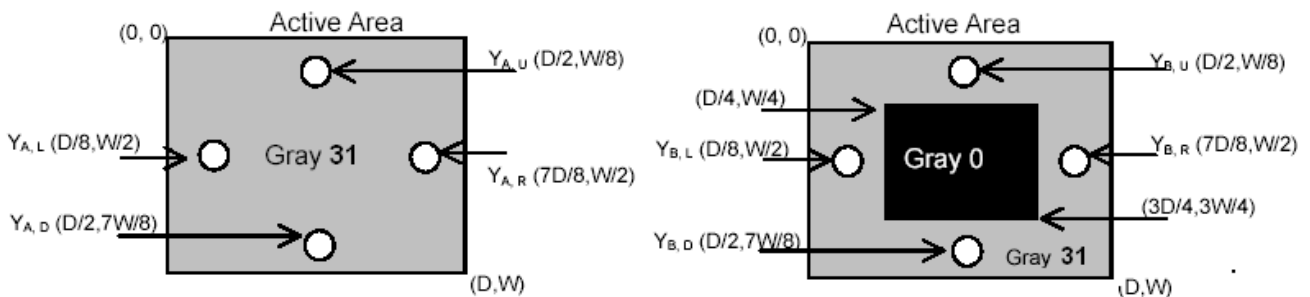

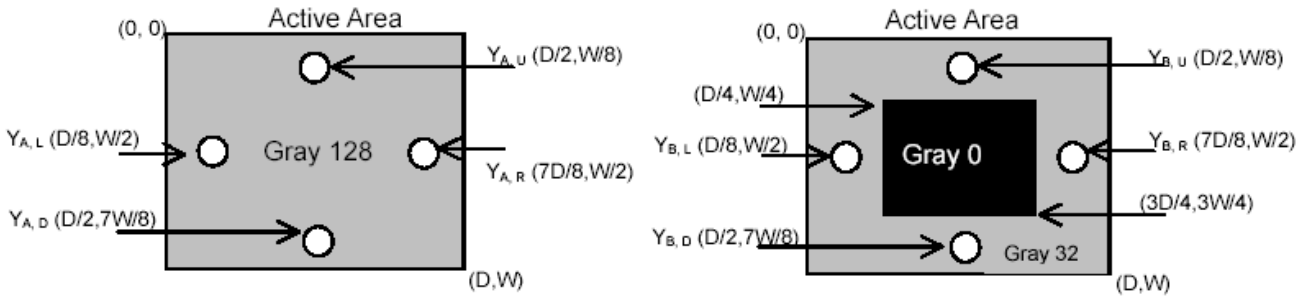

***7) Definition Gamma (VESA)**

Based on Customer Sample, take the average value as a standard center value and the variation range of gamma value caused by loop voltage error should be between +/- 0.2. the bellow figure shows how to obtain the gamma curve and γ (from gray level: 0、4、8-----60、63).



9. RELIABILITY TEST CONDITIONS

High Temp. Storage Test	80°C , 240 Hrs
High Temp. Operating Test	70°C , 240Hrs
Low Temp. Storage Test	-30°C , 240 Hrs
Low Temp. Operating Test	-20°C , 240 Hrs
High Temp/ High Humidity Operating Test	40°C , 95% RH , 240Hrs
High Temp./High Humidity Storage Test	60°C , 90% RH , 240Hrs
Thermal Shock Test	-30°C (0.5 Hr)~80°C (0.5 Hr) 56 Cycles
Low Air Pressure Test	533mbar(100mbar/min ramp), "-40C~55°C "(1C/min ramp)and 2hrs per each temperature
FPC Bending test	Bending degree is 180, bending 30 times and the bending radius is 1.0mm
FPC Insert/Remove test	30 times FPC insert/remove
Shock Test	980m/s ² ,Action time: 6ms, Time: 3 times for each direction, Direction:+/-X, +/-Y, +/-Z
ESD	150pF 、 330Ω 、 contact+-8KV/ Air+-15KV, NO DAMAGE
Package Vibration test	Frequency range: 10-55Hz, 1.2Grms, swep time: 1 minute, test period: 2 hours for each direction of X, Y, Z
Package Drop test	Height: 60cm, 1 corner, 3 edges, 6 surfaces: 1 time for each direction