



Chunghwa Picture Tubes, Ltd.

Product Specification

To : Geontek International Co.,Ltd.
Date : 2009/03/19

TFT LCD
CLAA102NA2CCN

ACCEPTED BY :

APPROVED BY	CHECKED BY	PREPARED BY

Prepared by :
Product Planning Management Division
NB TFT Product Business Unit
CHUNGHWA PICTURE TUBES, LTD.

Doc.No:	CLAA102NA2CCW-Geontek-V1-20090319	Issue Date:	20090319
---------	-----------------------------------	-------------	----------

CONTENTS

1. OVERVIEW.....	4
2. ABSOLUTE MAXIMUM RATINGS	5
3. ELECTRICAL CHARACTERISTICS.....	6
4. INTERFACE CONNECTION.....	8
5. INPUT SIGNAL	9
6. BLOCK DIAGRAM	12
7. MECHANICAL DIMENSION	13
8. OPTICAL CHARACTERISTICS	14
9. RELIABILITY TEST	16

1. OVERVIEW

CLAA102NA2CCN is 25.8cm(10.2") color TFT-LCD (Thin Film Transistor Liquid Crystal Display) module composed of LCD panel, driver ICs, control circuit and LED backlight. By applying 1024×600 images are displayed on the 10.2" diagonal screen. Display 262K colors by 6 Bit R.G.B signal input. Use 3.3 voltage to drive the power of LCD system. Use 5.0 voltage to drive the power of LED backlight.

General specification are summarized in the following table:

ITEM	SPECIFICATION			
Panel Size	10.2 inch(panel diagonal)			
Display Area (mm)	222.72(H) x 130.5(V) (10.2-inch diagonal)			
Number of Pixels	1024(H) × 3(RGB) × 600(V)			
Pixel Pitch (mm)	0.2175 (H) × 0.2175 (V)			
Color Pixel Arrangement	RGB vertical stripe			
Display Mode	Normally white			
Number of colors	262,144			
Brightness(cd/m ²)	200 Typ. (5-point Average)			
Response Time (ms)	20 Typ.			
Outline Dimension(mm)		Min.	Typ.	Max.
	Horizontal (H)	234.9	235.2	235.5
	Vertical (V)	145.6	145.9	146.2
	Depth (D)	5.4	5.7	6.0
Viewin Angle(BL on,CR ≥ 10)	90 degree (Horizontal.)			
	60 degree (Vertical)			
Power consumption (W)	3.6(w) (Typ)			
BL unit	LED			
Electrical Interface(data)	LVDS			
Viewing Direction	6 o'clock			
Weight(g)	250(Typ)			
Surface Treatment	Anti-Glare type, Hardness:3H			

2. ABSOLUTE MAXIMUM RATINGS

The following are maximum values which, if exceeded, may cause faulty operation or damage to the unit.

Item	Symbol	Min.	Max.	Unit	Note
Power Supply Voltage	V _{cc}	-0.3	4.0	V	
LED Supply Voltage	V _{LED}	-0.3	6.0	V	
Static Electricity	VESDc	-200	200	V	【Note2】
	VESDm	-15K	15K	V	
ICC Rush Current	IRUSH	-	1	A	【Note 3】
Operation Temperature	T _{op}	0	50	°C	【Note 1】
Storage Temperature	T _{stg}	-20	60	°C	【Note 1】

【Note】

【Note1】 If users use the product out off the environment operation range (temperature and humidity) , it will concern for visual quality.

【Note2】 Test Condition: IEC 61000-4-2 ,

VESDc : Contact discharge to input connector

VESDm : Discontact discharge to module

【Note3】 The input pulse-current measurement system as below :

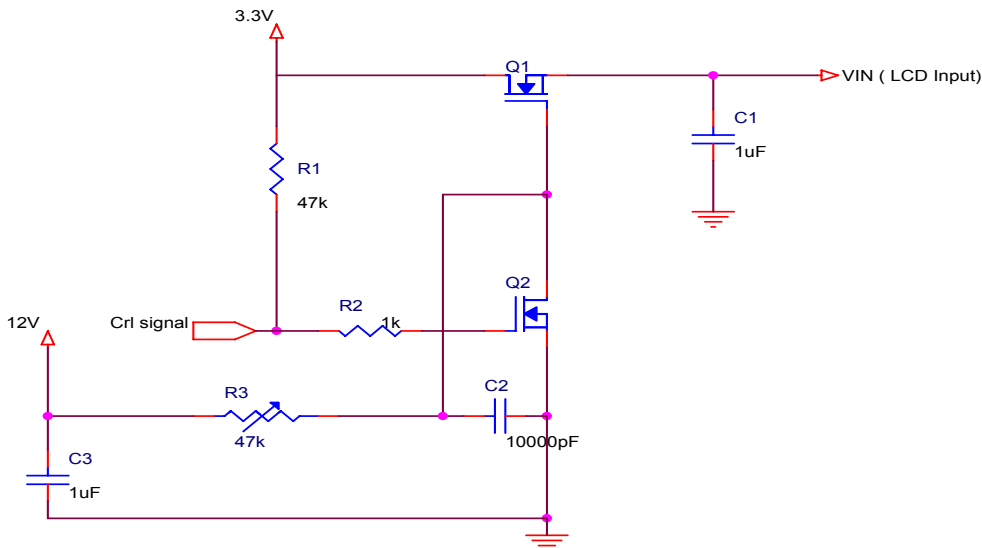

Control signal: High(+3.3V)→Low(GND)

Supply Voltage of rising time should be from R3 and C2 tune to 550 us.

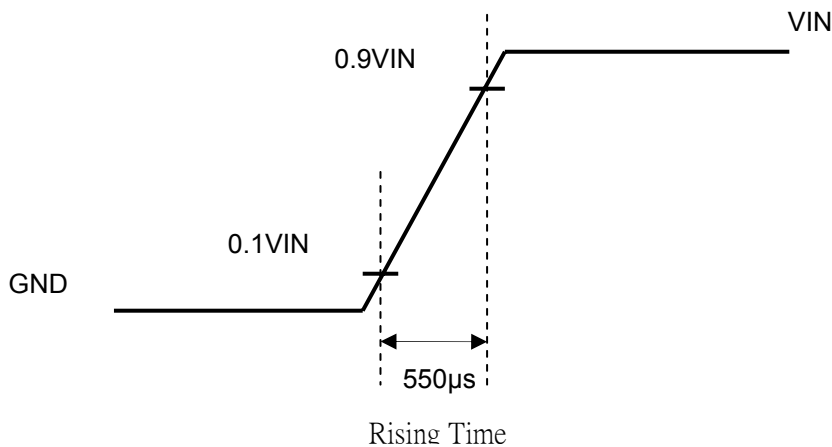

3. ELECTRICAL CHARACTERISTICS

3.1 TFT LCD Power Voltage

Ta=25°C

Item	Symbol	Min.	Typ	Max.	Unit	Note	
Power Supply Voltage For LCD	V _{CC}	3.0	3.3	3.6	V	【Note 1】	
Power Supply Voltage For LED	V _{LED}	4.5	5	5.5	V		
Logic Input Voltage (LVDS:IN+,IN-)	Input Voltage	V _{IN}	0	-	V _{CC}	V	【Note 2】
	Common Mode Voltage	V _{CM}	1.08	1.2	1.32	V	【Note 2】
	Differential Input Voltage	V _{ID}	250	350	450	mV	【Note 2】
	Threshold Voltage(high)	V _{TH}	-	-	100	mV	【Note 2】
	Threshold Voltage(low)	V _{TL}	-100	-	-	mV	【Note 2】
ADJ Input Voltage	Input Voltage(high)	V _{IH}	3.0	3.3	V		
	Input Voltage(low)	V _{IL}	GND	0.3	V		

Remarks :

【Note1】 VCC –dip codition:

- 1) When $2.7\text{V} \leq V_{CC} < 3.0\text{V}$, $t_d \leq 10\text{ms}$.
- 2) $V_{CC} > 3.0\text{V}$, VCC-dip condition should be same as VCC-turn-on condition.

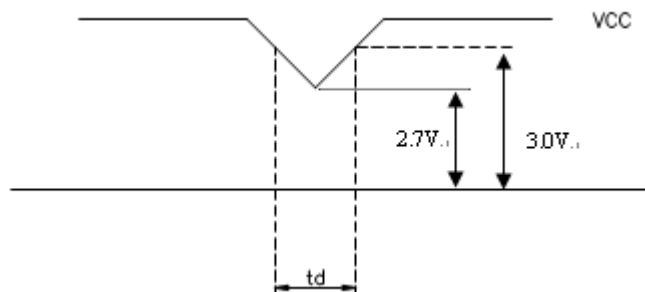

【Note 2】 LVDS signal

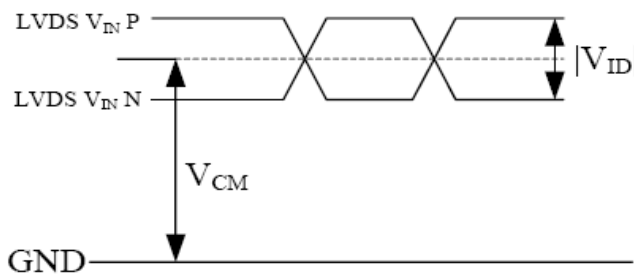

$$|V_{ID}| = |V_{TH} - V_{TL}|,$$

$$V_{CM} = (V_{TH} + V_{TL})/2$$

3.2 TFT-LCD Current Consumption

Item	Symbol	Min.	Typ	Max.	Unit	Note
LCD Power Current	I_{CC}	--	250	350	mA	【Note1】
LED Power Current	I_{LED}	--	500	600	mA	【Note2】

【Note1】 Typical: Under 64 gray pattern @ $V_{CC} = 3.3\text{ V}$
 Maximum: Under black pattern @ $V_{CC} = 3.0\text{ V}$

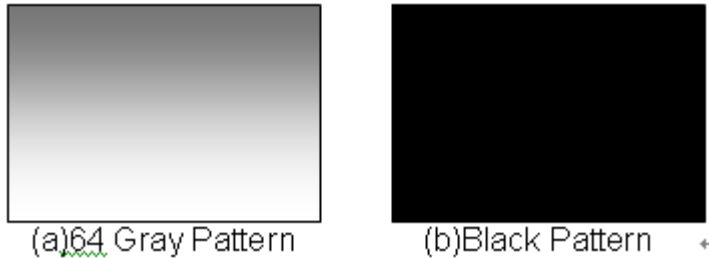

【Note2】 Typical: When V_{LED} is 5V
 Maximum: When V_{LED} is 4.5V

3.3 Power · Signal sequence

- $0.5 < t_1 \leq 10\text{ms}$
- $0 < t_2 \leq 50\text{ms}$
- $0 < t_3 \leq 50\text{ms}$
- $0 < t_4 \leq 10\text{ms}$
- $200\text{ms} \leq t_5$
- $200\text{ms} \leq t_6$
- $200\text{ms} \leq t_7$

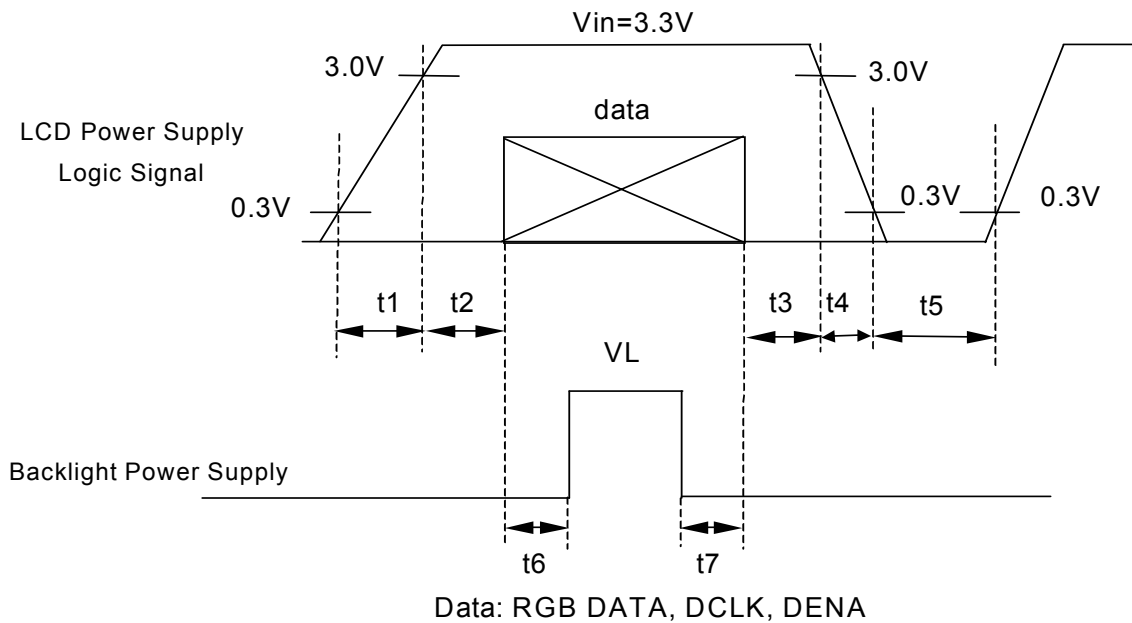

4. INTERFACE CONNECTION

4.1 CN1

Connector type : 093F30-B0B01A

Pin No.	SYMBOL	FUNCTION
1	GND	Ground
2	V _{CC}	+3.3V Power
3	V _{CC}	+3.3V Power
4	V _{EDID}	3.3V Power for NB
5	ADJ	Adjust for LED brightness
6	CLK _{EDID}	EDID Clock for NB
7	DATA _{EDID}	EDID Data for NB
8	RXIN0-	LVDS Signal(-)—channel 0
9	RXIN0+	LVDS Signal(+)—channel 0
10	GND	Ground
11	RXIN1-	LVDS Signal(-)—channel 1
12	RXIN1+	LVDS Signal(+)—channel 1
13	GND	Ground
14	RXIN2-	LVDS Signal(-)—channel 2
15	RXIN2+	LVDS Signal(+)—channel 2
16	GND	Ground
17	RXCLKIN-	LVDS Clock Signal(-)
18	RXCLKIN+	LVDS Clock Signal(+)
19	GND	Ground
20	NC	NC
21	NC	NC
22	GND	Ground
23	GND	Ground
24	V _{LED}	Power Supply for LED(V _{LED} =5.0±0.5)
25	V _{LED}	Power Supply for LED(V _{LED} =5.0±0.5)
26	V _{LED}	Power Supply for LED(V _{LED} =5.0±0.5)
27	NC/YD	(Touch Panel control pin)
28	NC/XL	(Touch Panel control pin)
29	NC/YU	(Touch Panel control pin)
30	NC/XR	(Touch Panel control pin)

【Note】

1) ADJ adjust brightness to control Pin , Pulse duty the bigger the brighter.

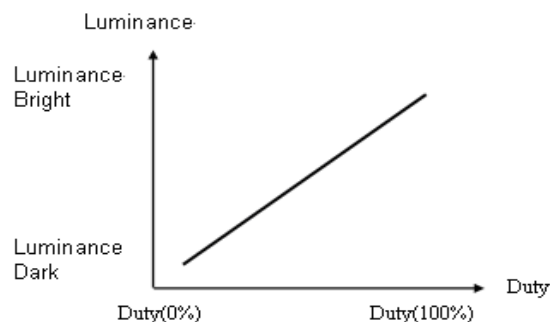

2) ADJ signal=0~3.3V , operation frequency : 25KHZ±5KHz

$$F = 25\text{KHz} \pm 5\text{KHz} , T = 0.05\text{ms}$$

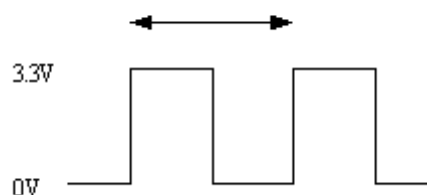

3) GND Pin must ground contact , can not be floating.

5. INPUT SIGNAL

5.1 Timing Specification

Item			Symbol	Min	Typ	Max	Unit
LVDS input signal sequence	CLK Frequency		fCLKin	39.05	45	51.42	MHz
	CLK Period		tCLKin	25.61	22.22	19.45	ns
LCD input timing	Horizontal	Horizontal Total Time	t _H	1160	1200	1240	tCLK
		Horizontal Effective Time	t _{HA}	1024	1024	1024	tCLK
		Horizontal Blank Time	t _{HB}	136	176	216	tCLK
	Vertical	Frame	fV	55	60	65	Hz
		Vertical Total Time	t _V	612	625	638	t _H
		Vertical EffectiveTime	t _{VA}	600	600	600	t _H
		Vertical Blank Time	t _{VB}	12	25	38	t _H

5.2 Timing sequence (Timing chart)

5.2.1 Horizontal Timing Sequence

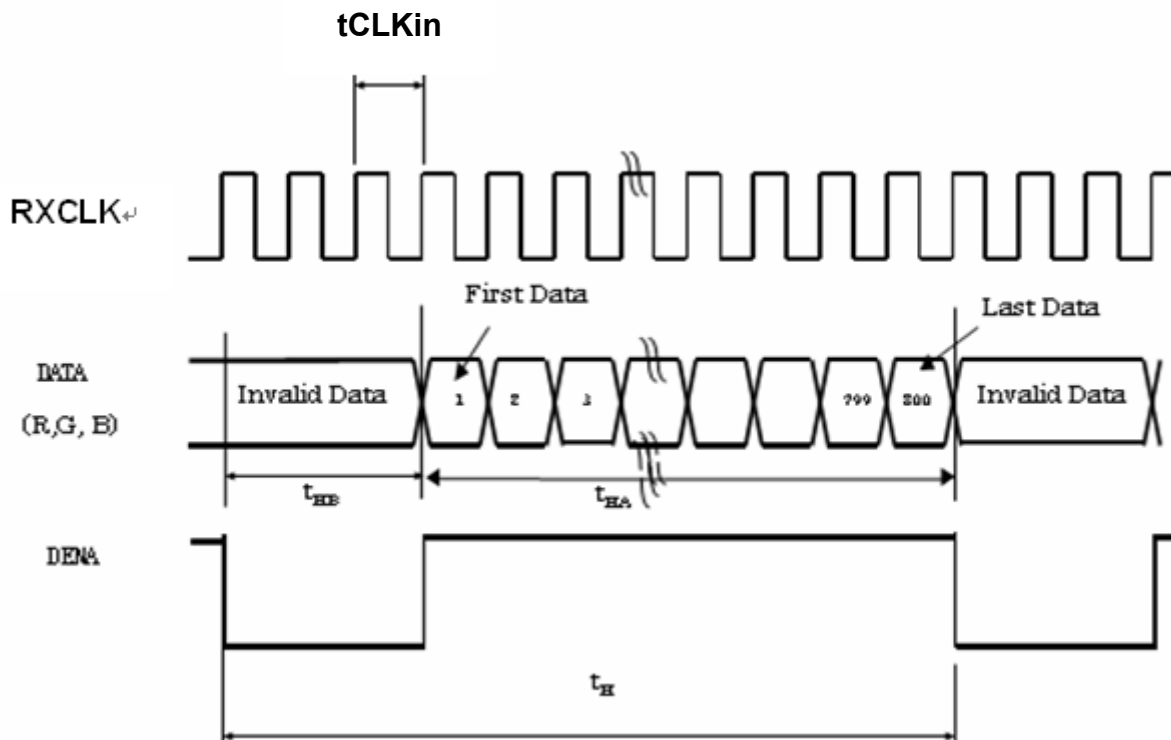

5.2.2 Vertical Timing Sequence

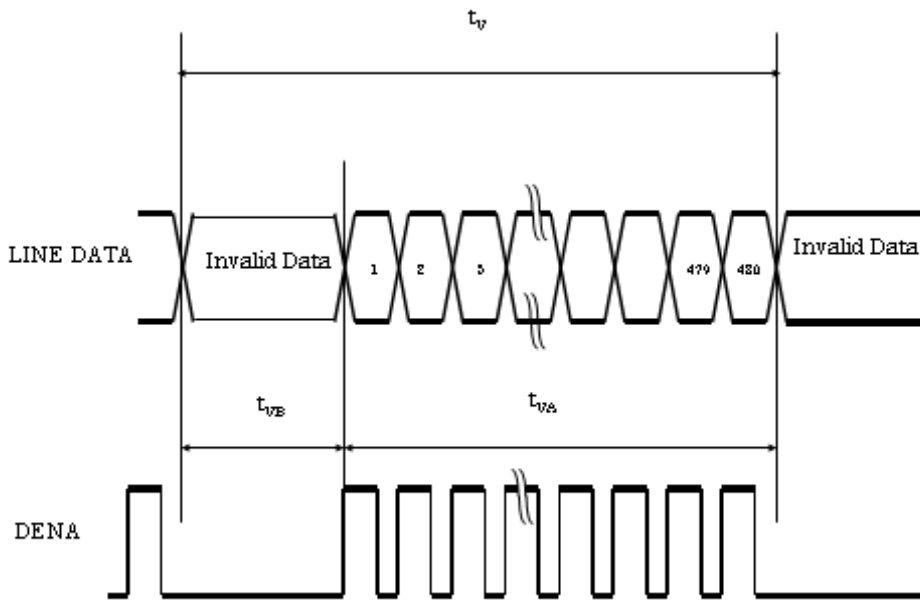

5.2.3 LVDS Input Data mapping

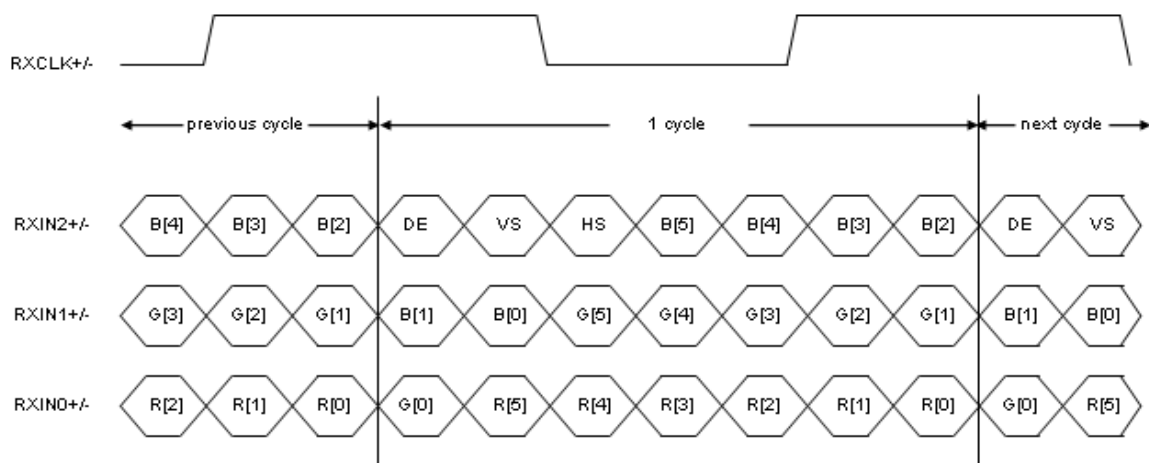

5.3 Color data assignment

COLOR	INPUT	R DATA						G DATA						B DATA					
		R5	R4	R3	R2	R1	R0	G5	G4	G3	G2	G1	G0	B5	B4	B3	B2	B1	B0
	DATA	MSB					LSB	MSB					LSB	MSB					LSB
BASI COLOR C	BLACK	0	0	0	0	0	0	0	0	0	0	0	0	0	0	0	0	0	0
	RED(63)	1	1	1	1	1	1	0	0	0	0	0	0	0	0	0	0	0	0
	GREEN(63)	0	0	0	0	0	0	1	1	1	1	1	1	0	0	0	0	0	0
	BLUE(63)	0	0	0	0	0	0	0	0	0	0	0	0	1	1	1	1	1	1
	CYAN	0	0	0	0	0	0	1	1	1	1	1	1	1	1	1	1	1	1
	MAGENTA	1	1	1	1	1	1	0	0	0	0	0	0	1	1	1	1	1	1
	YELLOW	1	1	1	1	1	1	1	1	1	1	1	1	0	0	0	0	0	0
	WHITE	1	1	1	1	1	1	1	1	1	1	1	1	1	1	1	1	1	1
RED	RED(0)	0	0	0	0	0	0	0	0	0	0	0	0	0	0	0	0	0	0
	RED(1)	0	0	0	0	0	1	0	0	0	0	0	0	0	0	0	0	0	0
	RED(2)	0	0	0	0	1	0	0	0	0	0	0	0	0	0	0	0	0	0
	RED(62)	1	1	1	1	1	0	0	0	0	0	0	0	0	0	0	0	0	0
RED(63)	1	1	1	1	1	1	0	0	0	0	0	0	0	0	0	0	0	0	
GREEN	GREEN(0)	0	0	0	0	0	0	0	0	0	0	0	0	0	0	0	0	0	0
	GREEN(1)	0	0	0	0	0	0	0	0	0	0	0	1	0	0	0	0	0	0
	GREEN(2)	0	0	0	0	0	0	0	0	0	0	1	0	0	0	0	0	0	0
	GREEN(62)	0	0	0	0	0	0	1	1	1	1	1	0	0	0	0	0	0	0
GREEN(63)	0	0	0	0	0	0	1	1	1	1	1	1	0	0	0	0	0	0	
BLUE	BLUE(0)	0	0	0	0	0	0	0	0	0	0	0	0	0	0	0	0	0	0
	BLUE(1)	0	0	0	0	0	0	0	0	0	0	0	0	0	0	0	0	0	1
	BLUE(2)	0	0	0	0	0	0	0	0	0	0	0	0	0	0	0	0	1	0
	BLUE(62)	0	0	0	0	0	0	0	0	0	0	0	0	1	1	1	1	1	0
BLUE(63)	0	0	0	0	0	0	0	0	0	0	0	0	1	1	1	1	1	1	

【Note1】 Definition of Gray Scale

color(n) : n is series of Gray Scale. The more n value is, the bright Gray Scale.

【Note2】 Data:1-High,0-Low

6. BLOCK DIAGRAM

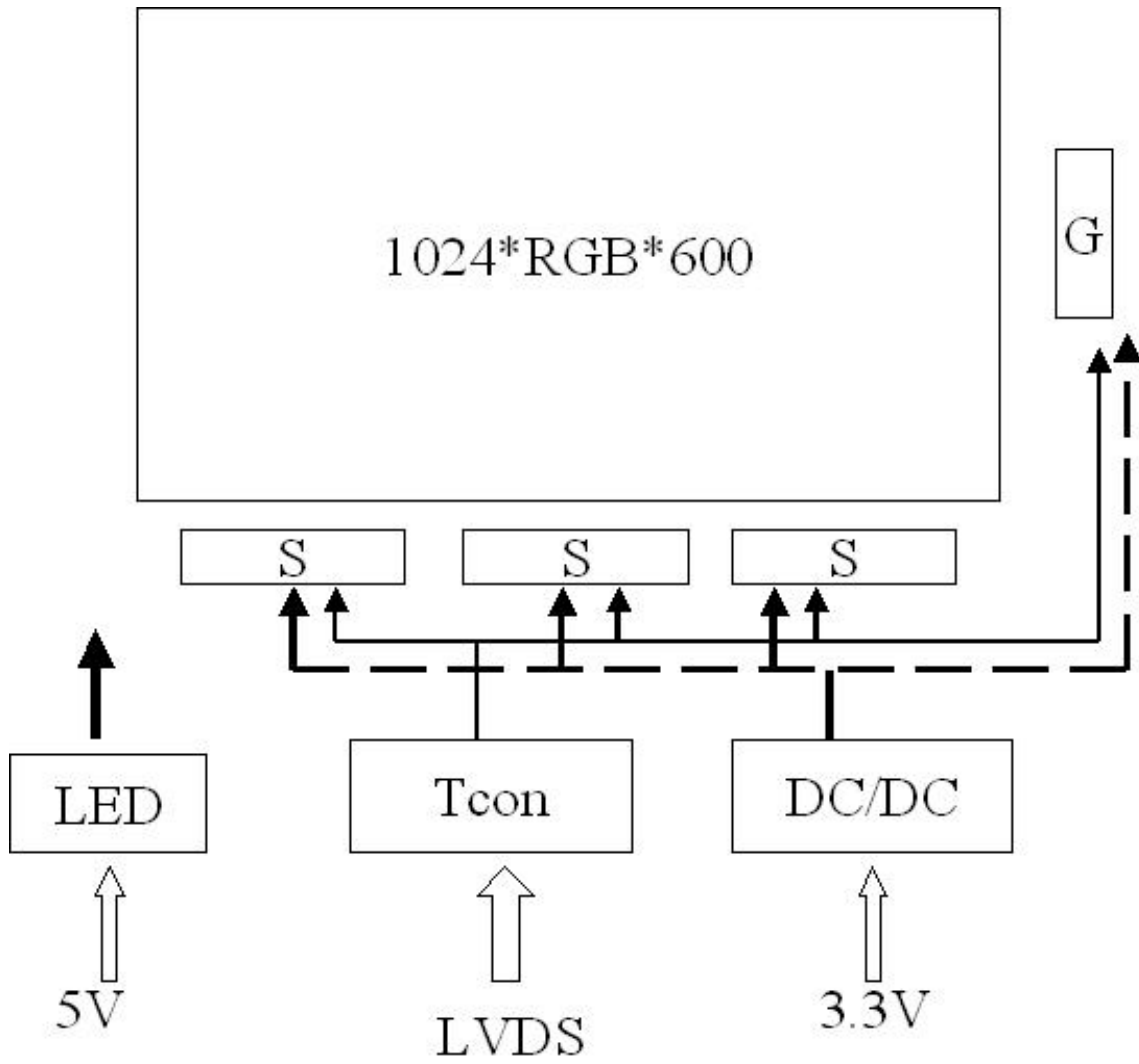

7. MECHANICAL DIMENSION

7.1 Front Side

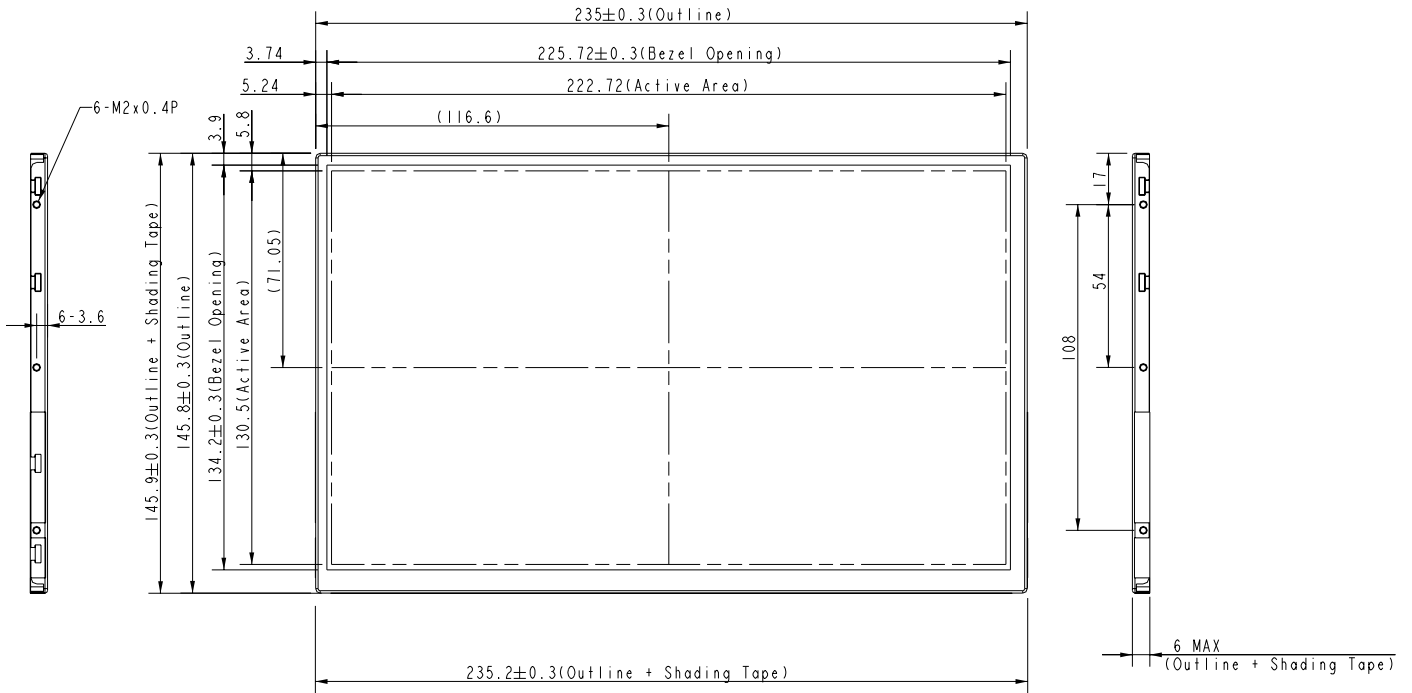

[Note] : Tolerance is ± 0.3 mm unless noted

7.2 Rear Side

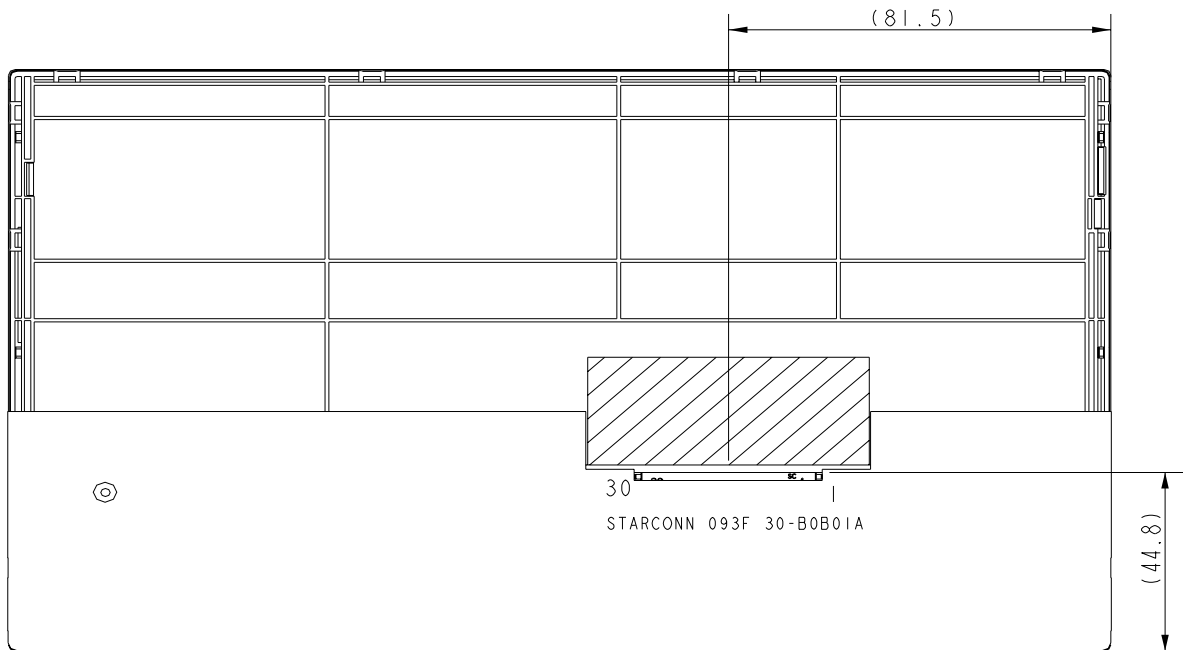

NOTE :

- 1.General tolerance= ± 0.3
- 2.Depth of screw insertion is 1.5mm MAX
- 3.Screw torque of side mount =2.5kg/cm MAX
- 4.User connector do not interference with plastic frame

[Note] : Tolerance is ± 0.3 mm unless noted

8. OPTICAL CHARACTERISTICS

Ta = 25°C, V_{CC} = 3.3V

ITEM	SYMBOL	CONDITION	MIN.	TYP.	MAX.	UNIT	NOTE	
Constrast Ratio	CR	Point-7	300	400	--	--	*1)*2)*3)	
Average Luminance of White	L _{W,AVE}	5 Points	170	200	--	cd/m ²	*1)*3)	
Response Time (White - Black)	Tr+ Tf	Point-7	--	20	30	ms	*1)*3)*5)	
Viewing Angle	Horizontal(φ)	Left(-)	CR ≥ 10 Point-7	-30	-45	--	Degree	*1)*2)*4)
		Right(+)		+30	+45	--		
	Vertical(θ)	Lower(-)		-20	-35	--		
		Upper(+)		+10	+25	--		
Color Coordinate	White	Wx Wy	θ = φ = 0° Point-7	0.273 0.289	0.313 0.329	0.353 0.369	--	*1)*3)
	Red	Rx Ry		0.521 0.293	0.561 0.333	0.601 0.373		
	Green	Gx Gy		0.304 0.539	0.344 0.579	0.384 0.619		
	Blue	Bx By		0.113 0.069	0.153 0.109	0.193 0.149		

Remarks :

*1)Measure condition : 25°C±2°C , 60±10%RH , under10 Lux in the dark room.BM-5A (TOPCON) , viewing angle2° , V_{CC}=3.3V ,V_{LED}=5V.

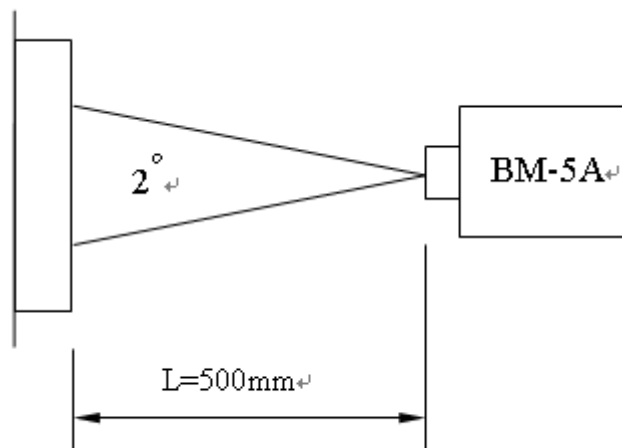

*2) Definition of contrast ratio :

Contrast Ratio (CR)= (White) Luminance of ON ÷ (Black) Luminance of OFF

- 3) Definition of luminance : Measure white luminance on the point 5 as figure8-1
 Definition of Luminance Uniformity: Measure white luminance on the point1~9 as figure8-1
 $\Delta L = [L(\text{MIN})/L(\text{MAX})] \times 100$

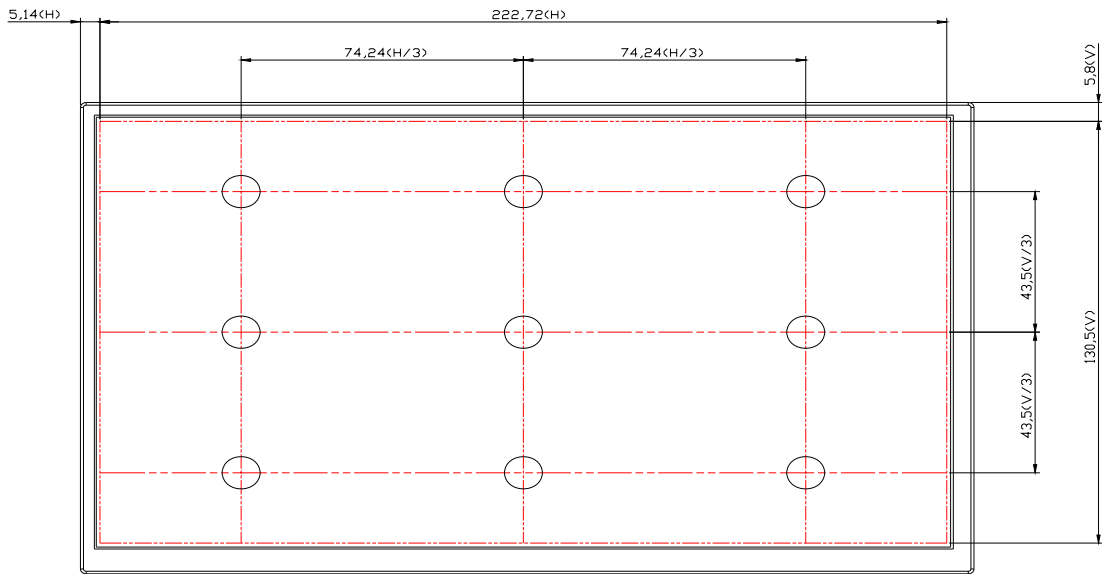

Fig8-1 Measuring point

- *4) Definition of Viewing Angle(θ, ψ), refer to Fig8-2 as below :
 These items are measured by EZ-CONTRAST (ELDIM) in the dark room. (no ambient light).

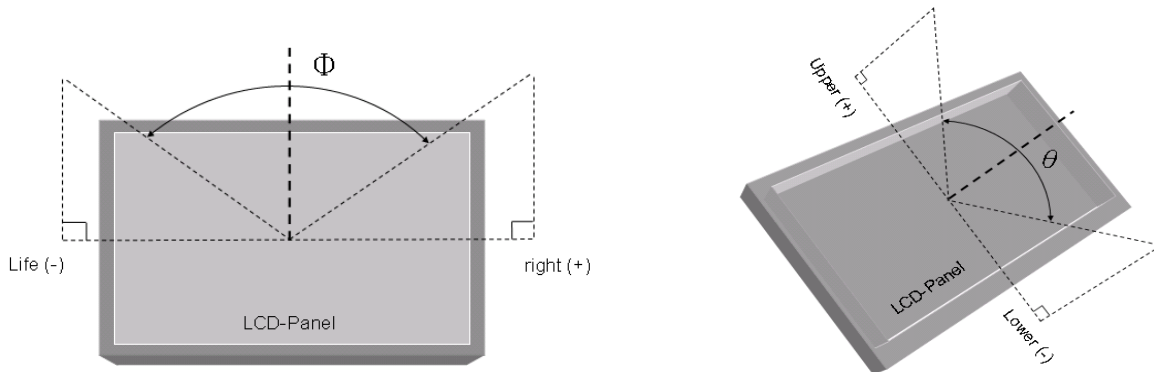

Fig8-2 Definition of Viewing Angle

- *5) Definition of Response Time.(White-Black)

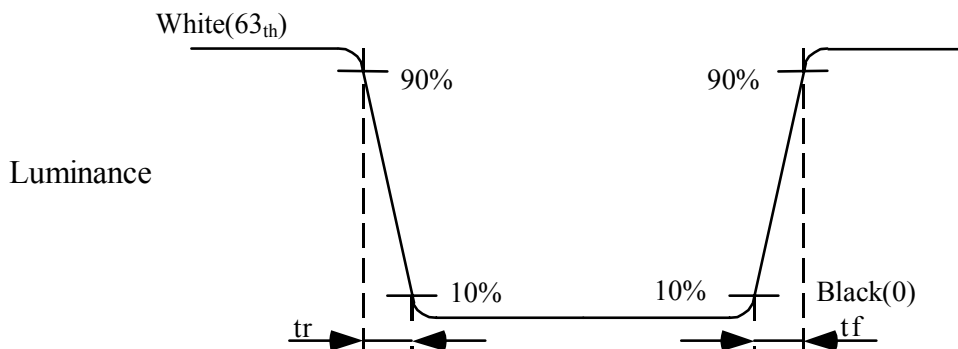

Fig8-3 Definition of Response Time(White-Black)

9. RELIABILITY TEST

9.1. Temperature and humidity

TEST ITEMS	CONDITIONS	NOTE
High Temperature Operation	50°C , 240Hrs	
High Temperature Storage	60°C , 240Hrs	
High Temperature High Humidity Operation	60°C , 90%RH , 240Hrs	No condensation
Low Temperature Operation	0°C , 240Hrs	
Low Temperature Storage	-20°C , 240Hrs	
Thermal Shock	-20°C (0.5Hr) ~ 60°C(0.5Hr) 200 cycles	

9.2. Shock and Vibration

TEST ITEMS	CONDITIONS
Shock (Non-operation)	<ul style="list-style-type: none"> ● Shock level:980m/s²(equal to 100G) ● Waveform:half sinusoidal wave,6ms. ● Number of shocks:one shock input in each direction of three mutually perpendicular axes for a total of three shock inputs.
Vibration (Non-operation)	<ul style="list-style-type: none"> ● Frequency range: 10 to 500 Hz ● Vibration:sinusoidal wave,perpendicular axis(x,z,y axis). ● Sweep: 1.5 g zero-to-peak, 10 to 500 Hz, 0.5 octave/minute.

9.3. ESD Test

ITEM	CONDITION	NOTE
ESD	150pF , 330Ω , ±8KV&±15KV air test	*1)
	200pF , 0Ω , ±250V contact test	*2)

NOTE :

*1) LCD glass and metal bezel

*2) IF connector pins

9.4 Judgment Standard

The Judgment of the above test should be made as follow:

Pass:Normal display image with no obvious non-uniformity and no line defect.Partial transformation of the module parts should be ignored.

Fail:No display image,obvious non-uniform,or line defect.