



Chunghwa Picture Tubes, Ltd.

Technical Specification

To : SCL
Date : 2011 / 04 / 07

TFT LCD
CLAA133UA01

ACCEPTED BY :

| APPROVED BY | CHECKED BY | PREPARED BY |
|--------------|------------|-------------|
| Ronald Huang | Roger Liu | Carol Shen |

Prepared by : Design General Division, VD Business Unit

CHUNGHWA PICTUER TUBES, LTD.

1127 Hopin Rd., Padeh, Taoyuan, Taiwan 334, R.O.C.

TEL: +886-3-3675151 FAX: +886-3-377-3003

| | | | |
|---------|-----------------------------|-------------|------------|
| Doc.No: | CLAA133UA01-SCL-V1-20110407 | Issue Date: | 2011/04/07 |
|---------|-----------------------------|-------------|------------|

CONTENTS

| NO. | ITEM | Page |
|------------|---|-------------|
| 1 | OVERVIEW | 3 |
| 2 | ABSOLUTE MAXIMUM RATINGS | 4 |
| 3 | ELECTRICAL CHARACTERISTICS | 5 |
| 4 | CONNECTOR INTERFACE PIN & FUNCTION | 10 |
| 5 | INTERFACE TIMING CHART | 11 |
| 6 | BLOCK DIAGRAM | 14 |
| 7 | MECHANICAL SPECIFICATION | 15 |
| 8 | OPTICAL CHARACTERISTICS | 17 |
| 9 | RELIABILITY TEST CONDITIONS | 21 |
| 10 | HANDLING PRECAUTIONS FOR TFT-LCD MODULE | 22 |
| | | |
| | | |
| | | |

1. OVERVIEW

CLAA133UA01 is 13.3" color (16 : 9) TFT-LCD (Thin Film Transistor Liquid Crystal Display) module composed of LCD panel, LVDS driver ICs, control circuit and backlight. By applying 6 bit digital data, 1600×RGB (3) ×900, 262K-color images are displayed on the 13.3" diagonal screen. General specifications are summarized in the following table :

| ITEM | SPECIFICATION |
|-------------------------|--|
| Display Area | 293.28(H) x 164.97(V) (mm) (13.3-inch diagonal) |
| Number of Pixels | 1600 x 3 (RGB) x 900 |
| Pixel Pitch | 0.1833 (H) x 0.1833 (V) (mm) |
| Color Pixel Arrangement | RGB vertical stripe |
| Display Mode | Normally white |
| Number of Colors | 262,144(6bits) (LVDS) |
| Gamut | 42%(min)/45% (Typ) |
| Optimum Viewing Angle | 6 o'clock |
| Response Time | 16ms (Typ) |
| Surface Treatment | AG |
| Viewing Angle | 40° 、 -40°/15° 、 -30°(min.) |
| Brightness | 300 cd/m ² (5point) (Typ) |
| Uniformity | 80% |
| Consumption of Power | 4.3W (Max) |
| Module Size | 314.6(W)x 192.75(H)x3.1(D) (mm) (Max) 314.6(W)x 192.75(H)x4.1(with thermal pad) (mm) (Max) |
| Module Weight | 250g (Max) |

The LCD Products listed on this document are not suitable for use of aerospace equipment, submarine cable, and nuclear reactor control system and life support systems. If customers intend to use these LCD products for applications listed above or those not included in the "Standard" list as follows, please contact our sales in advance.

Standard : Computer, Office equipment, Communication equipment, Test and Measurement equipment, Machine tool, Industrial robot, Audio and Visual equipment, Other consumer products.

2. ABSOLUTE MAXIMUM RATINGS

The following are maximum value, which if exceeded, may cause faulty operation or damage to the unit.

| ITEM | SYMBOL | MIN | MAX | UNIT | NOTE |
|--------------------------|--------|-----|-----|------|------------------|
| LCD Power Voltage | VCC | 0 | 4.0 | V | |
| LED Driver Input Voltage | VBL+ | 7 | 21 | V | |
| Operation Temperature | Top | 0 | 50 | °C | *1).*2).*3).*4). |
| Storage Temperature | Tstg | -25 | 65 | °C | *1).*2).*3). |

【Note】

- *1) The relative temperature and humidity range are as below sketch, 90%RH Max. ($T_a \leq 40^\circ\text{C}$)
- *2) The maximum wet bulb temperature $\leq 39^\circ\text{C}$ ($T_a > 40^\circ\text{C}$) and without dewing.
- *3) If product in environment which over the definition of the relative temperature and humidity out of range too long, it will affect visual of LCD.
- *4) If you operate LCD in normal temperature range, the center surface of panel should be under 50°C .

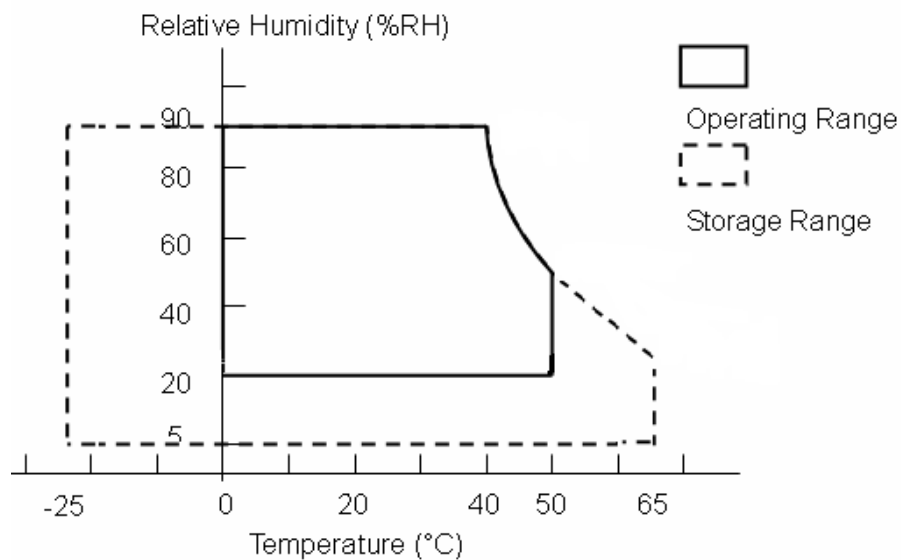

3. ELECTRICAL CHARACTERISTICS

(A) TFT LCD

| ITEM | SYMBOL | MIN | TYP | MAX | UNIT | NOTE | |
|-------------------------------------|----------------------------|-----|-------|------|-------|------|-------------------------|
| LCD Power Voltage | VCC | 3.0 | 3.3 | 3.6 | V | *1) | |
| LCD Power Current | ICC | - | 320 | 420 | mA | *2) | |
| Rush Current | Irush | - | - | 2 | A | *4) | |
| Logic Input Voltage (LVDS: IN+,IN-) | Common Voltage | VCM | 1.125 | 1.25 | 1.375 | V | *3) |
| | Differential Input Voltage | VID | 250 | 350 | 450 | mV | *3) |
| | Threshold Voltage (HIGH) | VTH | - | - | 100 | mV | *3) When VCM = +1.2V |
| | Threshold Voltage (LOW) | VTL | -100 | - | - | mV | |

【Note】

*1) Power Sequence :

- $0.50\text{ ms} \leq t1 \leq 10\text{ ms}$
- $0.01\text{ ms} < t2 \leq 50\text{ ms}$
- $0.01\text{ ms} < t3 \leq 50\text{ ms}$
- $500\text{ ms} \leq t4$
- $200\text{ ms} \leq t5$
- $200\text{ ms} \leq t6$

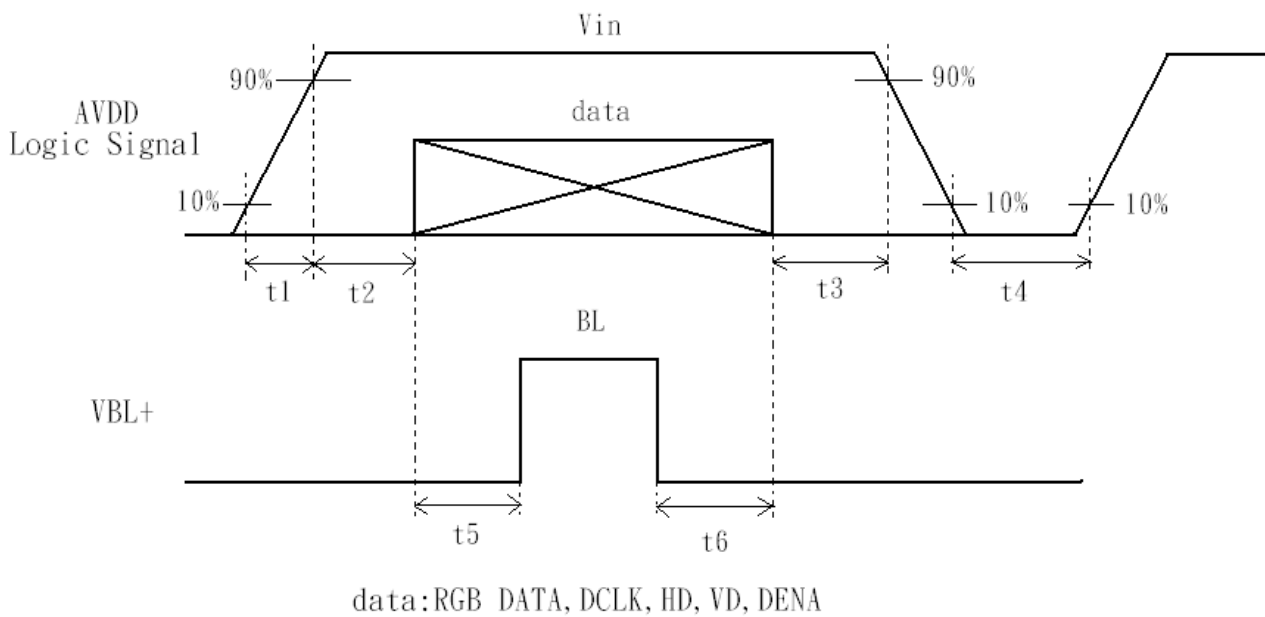

VCC-dip state

(1) when $3.0V > VCC \geq 2.7V$, $t_d \leq 10$ ms.

(2) when $VCC < 2.7V$, VCC-dip condition should as the VCC-turn-off condition.

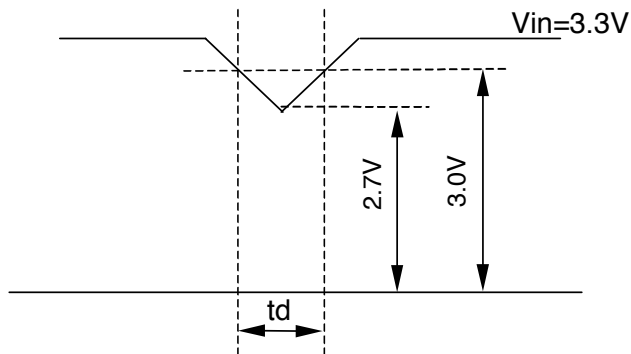

*2) Typical value is Mosaic (32*36 Checker board) Pattern : 900 line mode.

Circuit condition (Typ) : $VCC=3.3$ V , $f_v=60$ Hz , $f_H=55.92$ KHz , $f_{CLK}=50.1$ MHz

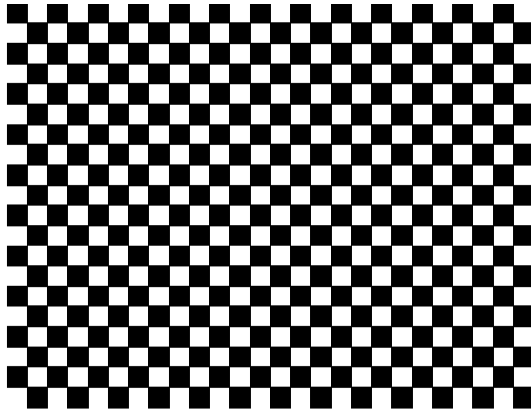

Max value is Black Pattern : 900 line mode.

Circuit condition (Max) : $VCC=3.3$ V , $f_v=60$ Hz , $f_H=55.92$ KHz , $f_{CLK}=50.1$ MHz

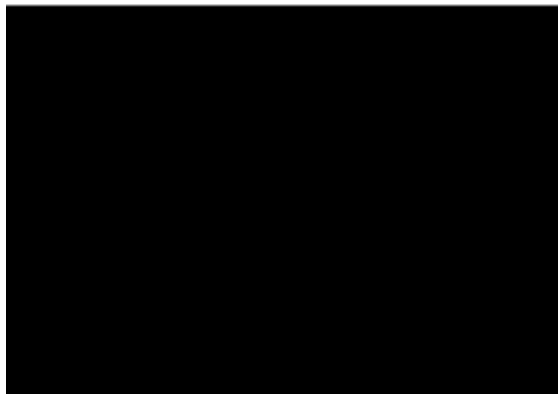

*3) LVDS Signal Definite :

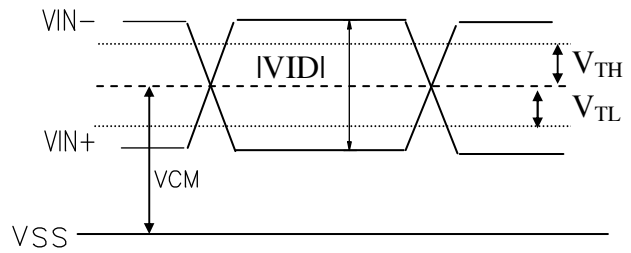
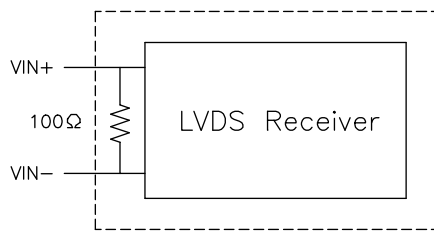

VIN+ : Positive differential DATA & CLK Input

VIN- : Negative differential DATA & CLK Input

*4) Irush measure condition

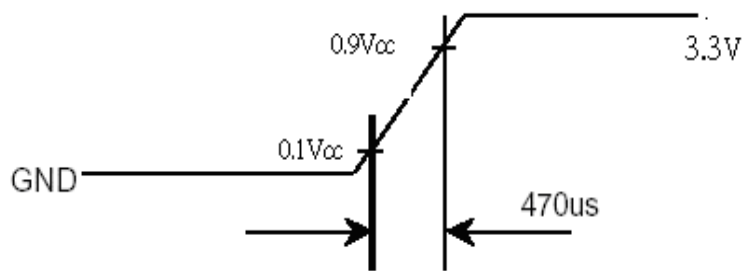
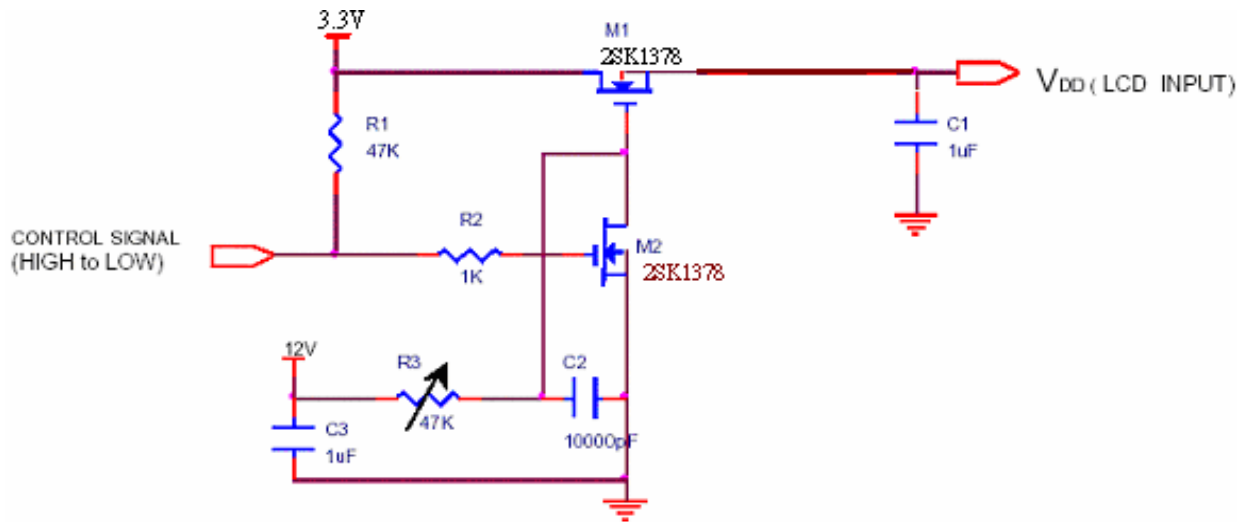

(B) BACK LIGHT

(a.) ELECTRICAL CHARACTERISTICS

Ta=25°C

| ITEM | SYMBOL | MIN | TYP | MAX | UNIT | NOTE |
|--------------------------|----------------|------|------|------|------|--------------------------|
| LED Driver Input Voltage | VBL+ | 7 | 12 | 21 | V | |
| LED Driver Input Current | IBL+ | | | 650 | mA | *1) |
| Forward Voltage | V _F | | 2.9 | 3.0 | V | *2) I _F =20mA |
| Forward Current | I _F | 19.5 | 20 | 20.5 | mA | *2) |
| Power Consumption | PLED | 2.66 | 2.73 | 2.9 | W | *2)*3) |
| PWM Frequency | PWM_BL | 180 | 200 | 1K | Hz | *2)I _F =20mA |
| Duty ratio | Dim | 10 | | 100 | % | |

(b.) LED LIFE – TIME

| ITEM | CONDITION | MIN | TYP | MAX | UNIT | NOTE |
|-----------|------------------------------|-------|-----|-----|------|------|
| Life Time | I _F =20mA、Ta=25°C | 15000 | | | hrs | *4) |

(c.) LED ON/OFF Sequence :

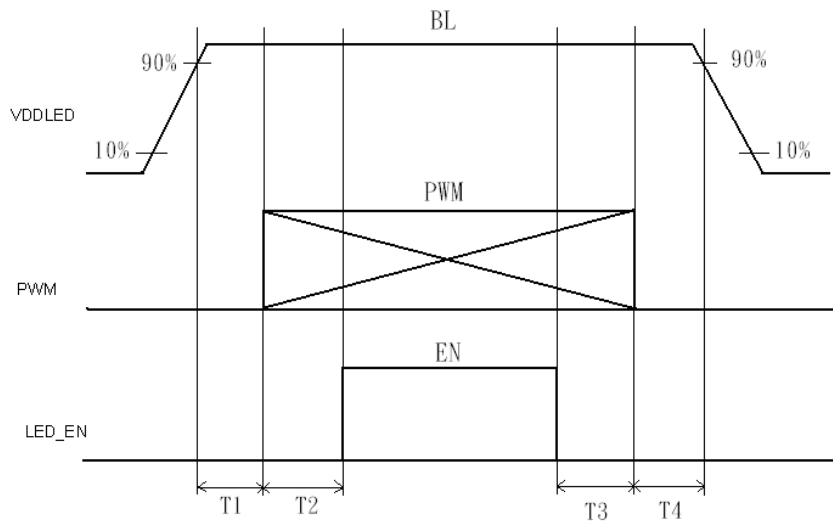

10ms ≤ T1

0ms ≤ T3

10ms ≤ T2

10ms ≤ T4

- *1) Maximum LED Driver Input Current at 7V Input Voltage/PWM Duty 100%.
- *2) Measure method : a. LED current is measured by utilizing a current meter as show below.
b. System power PLED is measured at input voltage 12V.

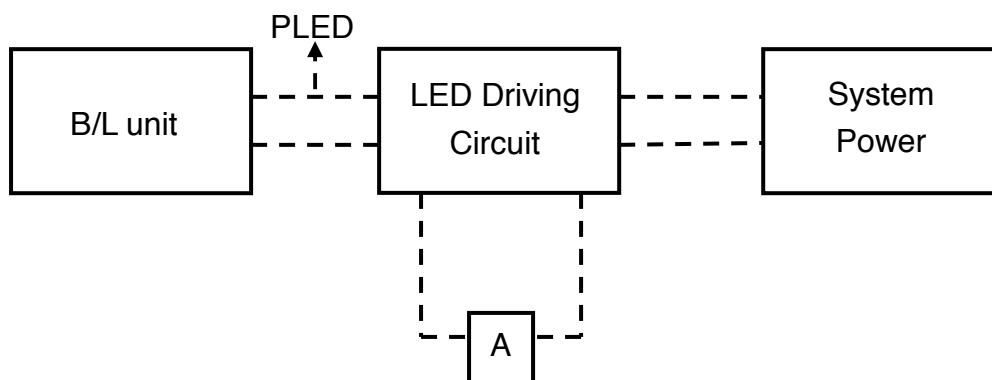

- *3) Calculator value for reference $I_F \times V_F \times N = PLED$
- *4) Life time means that estimated time to 50% degradation of initial luminous intensity.

4. Connector Interface PIN & Function

CN (Interface signal)

Outlet connector: TYCO_5-2069716-3

| Pin No. | SYMBOL | FUNCTION |
|---------|----------|---|
| 1 | NC | No Connect |
| 2 | VDD | Power Supply, 3.3 V (typical) |
| 3 | VDD | Power Supply, 3.3 V (typical) |
| 4 | V_EEDID | DDC 3.3V power |
| 5 | NC | No Connect |
| 6 | SCL_EDID | DDC Clock |
| 7 | SDA_EDID | DDC Data |
| 8 | RXO0- | Minus signal of odd channel 0(LVDS) |
| 9 | RXO0+ | Plus signal of odd channel 0(LVDS) |
| 10 | GND | Ground |
| 11 | RXO1- | Minus signal of odd channel 1(LVDS) |
| 12 | RXO1+ | Plus signal of odd channel 1(LVDS) |
| 13 | GND | Ground |
| 14 | RXO2- | Minus signal of odd channel 2(LVDS) |
| 15 | RXO2+ | Plus signal of odd channel 2(LVDS) |
| 16 | GND | Ground |
| 17 | RXOC- | Minus signal of odd clock channel (LVDS) |
| 18 | RXOC+ | Plus signal of odd clock channel (LVDS) |
| 19 | NC | Ground |
| 20 | RXE0- | Minus signal of even channel 0(LVDS) |
| 21 | RXE0+ | Plus signal of even channel 0(LVDS) |
| 22 | GND | Ground |
| 23 | RXE1- | Minus signal of even channel 1(LVDS) |
| 24 | RXE1+ | Plus signal of even channel 1(LVDS) |
| 25 | GND | Ground |
| 26 | RXE2- | Minus signal of even channel 2(LVDS) |
| 27 | RXE2+ | Plus signal of even channel 2(LVDS) |
| 28 | GND | Ground |
| 29 | RXEC- | Minus signal of even clock channel (LVDS) |
| 30 | RXEC+ | Plus signal of even clock channel (LVDS) |
| 31 | VLED_GND | Ground - LED |
| 32 | VLED_GND | Ground - LED |
| 33 | VLED_GND | Ground - LED |
| 34 | NC | No Connect |
| 35 | BLIM | System PWM Signal Input (+3.3V Swing) |
| 36 | BL_ON | LED enable pin (+3.3V Input) |
| 37 | NC | |
| 38 | VDDLED | 7.5V – 21V LED power |
| 39 | VDDLED | 7.5V – 21V LED power |
| 40 | VDDLED | 7.5V – 21V LED power |

5. INTERFACE TIMING CHART

(1) LVDS input time sequence

(a). Horizontal sequence

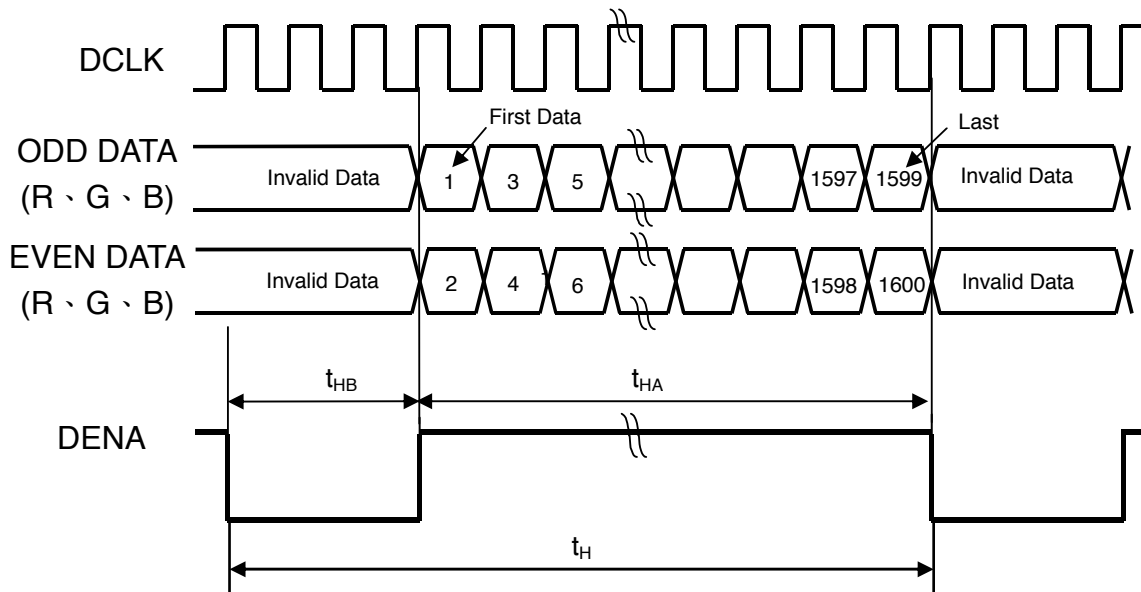

(b). Vertical sequence

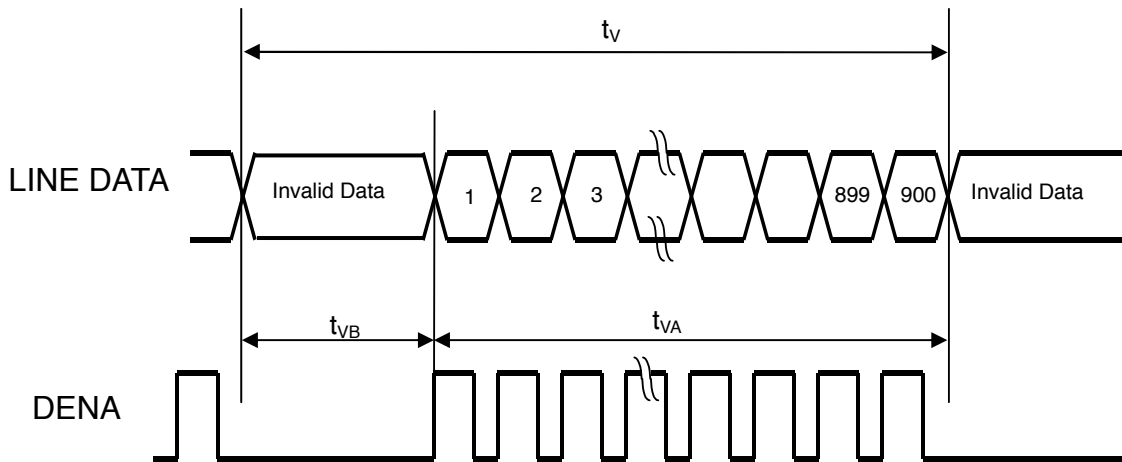

(2) Timing Chart

| ITEM | | SYMBOL | MIN | TYP | MAX | UNIT | | |
|--------------------------------|------------|------------|------------------------|----------|-------|-------|-----|-----------|
| LCD Timing | Frame Rate | - | 55 | 60 | 60 | Hz | | |
| | DCLK | Frequency | f_{CLK} | 44.82 | 50.1 | 55.49 | MHz | |
| | | Period | t_{CLK} | 18.02 | 19.96 | 23.31 | ns | |
| | DENA | Horizontal | Horizontal total time | t_H | 880 | 896 | 986 | t_{CLK} |
| | | | Horizontal Active time | t_{HA} | 800 | 800 | 800 | t_{CLK} |
| | | | Horizontal Blank time | t_{HB} | 80 | 96 | 186 | t_{CLK} |
| | | Vertical | Vertical total time | t_V | 926 | 932 | 938 | t_H |
| | | | Vertical Active time | t_{VA} | 900 | 900 | 900 | t_H |
| | | | Vertical Blank time | t_{VB} | 26 | 32 | 38 | t_H |
| LVDS spread spectrum range *3) | | | -2 | | 2 | % | | |

【Note】

- *1) DENA (DATA ENABLE) usually is positive.
- *2) During the whole blank period, DCLK should keep input.
- *3) LVDS input clock is 85MHz and modulation rate is fixed 100KHz

(3) DATA mapping

| Color | Input Data | R DATA | | | | | G DATA | | | | | B DATA | | | | | | | |
|-------------|------------|----------|----|----|----|----|--------|-----|----|----|----|--------|-----|-----|----|----|----|----|-----|
| | | R5 | R4 | R3 | R2 | R1 | R0 | G5 | G4 | G3 | G2 | G1 | G0 | B5 | B4 | B3 | B2 | B1 | B0 |
| | | MSB | | | | | LSB | MSB | | | | | LSB | MSB | | | | | LSB |
| Basic Color | Black | 0 | 0 | 0 | 0 | 0 | 0 | 0 | 0 | 0 | 0 | 0 | 0 | 0 | 0 | 0 | 0 | 0 | 0 |
| | Red(63) | 1 | 1 | 1 | 1 | 1 | 1 | 0 | 0 | 0 | 0 | 0 | 0 | 0 | 0 | 0 | 0 | 0 | 0 |
| | Green(63) | 0 | 0 | 0 | 0 | 0 | 0 | 1 | 1 | 1 | 1 | 1 | 1 | 0 | 0 | 0 | 0 | 0 | 0 |
| | Blue(63) | 0 | 0 | 0 | 0 | 0 | 0 | 0 | 0 | 0 | 0 | 0 | 0 | 1 | 1 | 1 | 1 | 1 | 1 |
| | Cyan | 0 | 0 | 0 | 0 | 0 | 0 | 1 | 1 | 1 | 1 | 1 | 1 | 1 | 1 | 1 | 1 | 1 | 1 |
| | Magenta | 1 | 1 | 1 | 1 | 1 | 1 | 0 | 0 | 0 | 0 | 0 | 0 | 1 | 1 | 1 | 1 | 1 | 1 |
| | Yellow | 1 | 1 | 1 | 1 | 1 | 1 | 1 | 1 | 1 | 1 | 1 | 1 | 0 | 0 | 0 | 0 | 0 | 0 |
| | White | 1 | 1 | 1 | 1 | 1 | 1 | 1 | 1 | 1 | 1 | 1 | 1 | 1 | 1 | 1 | 1 | 1 | 1 |
| RED | RED(0) | 0 | 0 | 0 | 0 | 0 | 0 | 0 | 0 | 0 | 0 | 0 | 0 | 0 | 0 | 0 | 0 | 0 | 0 |
| | RED(1) | 0 | 0 | 0 | 0 | 0 | 1 | 0 | 0 | 0 | 0 | 0 | 0 | 0 | 0 | 0 | 0 | 0 | 0 |
| | RED(2) | 0 | 0 | 0 | 0 | 1 | 0 | 0 | 0 | 0 | 0 | 0 | 0 | 0 | 0 | 0 | 0 | 0 | 0 |
| | RED(62) | 1 | 1 | 1 | 1 | 1 | 0 | 0 | 0 | 0 | 0 | 0 | 0 | 0 | 0 | 0 | 0 | 0 | 0 |
| | RED(63) | 1 | 1 | 1 | 1 | 1 | 1 | 0 | 0 | 0 | 0 | 0 | 0 | 0 | 0 | 0 | 0 | 0 | 0 |
| | Green | Green(0) | 0 | 0 | 0 | 0 | 0 | 0 | 0 | 0 | 0 | 0 | 0 | 0 | 0 | 0 | 0 | 0 | 0 |
| Green(1) | | 0 | 0 | 0 | 0 | 0 | 0 | 0 | 0 | 0 | 0 | 0 | 1 | 0 | 0 | 0 | 0 | 0 | 0 |
| Green(2) | | 0 | 0 | 0 | 0 | 0 | 0 | 0 | 0 | 0 | 0 | 1 | 0 | 0 | 0 | 0 | 0 | 0 | 0 |
| Green(62) | | 0 | 0 | 0 | 0 | 0 | 0 | 1 | 1 | 1 | 1 | 1 | 0 | 0 | 0 | 0 | 0 | 0 | 0 |
| Green(63) | | 0 | 0 | 0 | 0 | 0 | 0 | 1 | 1 | 1 | 1 | 1 | 1 | 0 | 0 | 0 | 0 | 0 | 0 |
| Blue | | Blue(0) | 0 | 0 | 0 | 0 | 0 | 0 | 0 | 0 | 0 | 0 | 0 | 0 | 0 | 0 | 0 | 0 | 0 |
| | Blue(1) | 0 | 0 | 0 | 0 | 0 | 0 | 0 | 0 | 0 | 0 | 0 | 0 | 0 | 0 | 0 | 0 | 0 | 1 |
| | Blue(2) | 0 | 0 | 0 | 0 | 0 | 0 | 0 | 0 | 0 | 0 | 0 | 0 | 0 | 0 | 0 | 0 | 1 | 0 |
| | Blue(62) | 0 | 0 | 0 | 0 | 0 | 0 | 0 | 0 | 0 | 0 | 0 | 0 | 1 | 1 | 1 | 1 | 1 | 0 |
| | Blue(63) | 0 | 0 | 0 | 0 | 0 | 0 | 0 | 0 | 0 | 0 | 0 | 0 | 1 | 1 | 1 | 1 | 1 | 1 |

【Note】

- 1) Gray level:
Color(n) : n is level order; higher n means brighter level.
- 2) DATA:
1: high , 0: low

6. BLOCK DIAGRAM

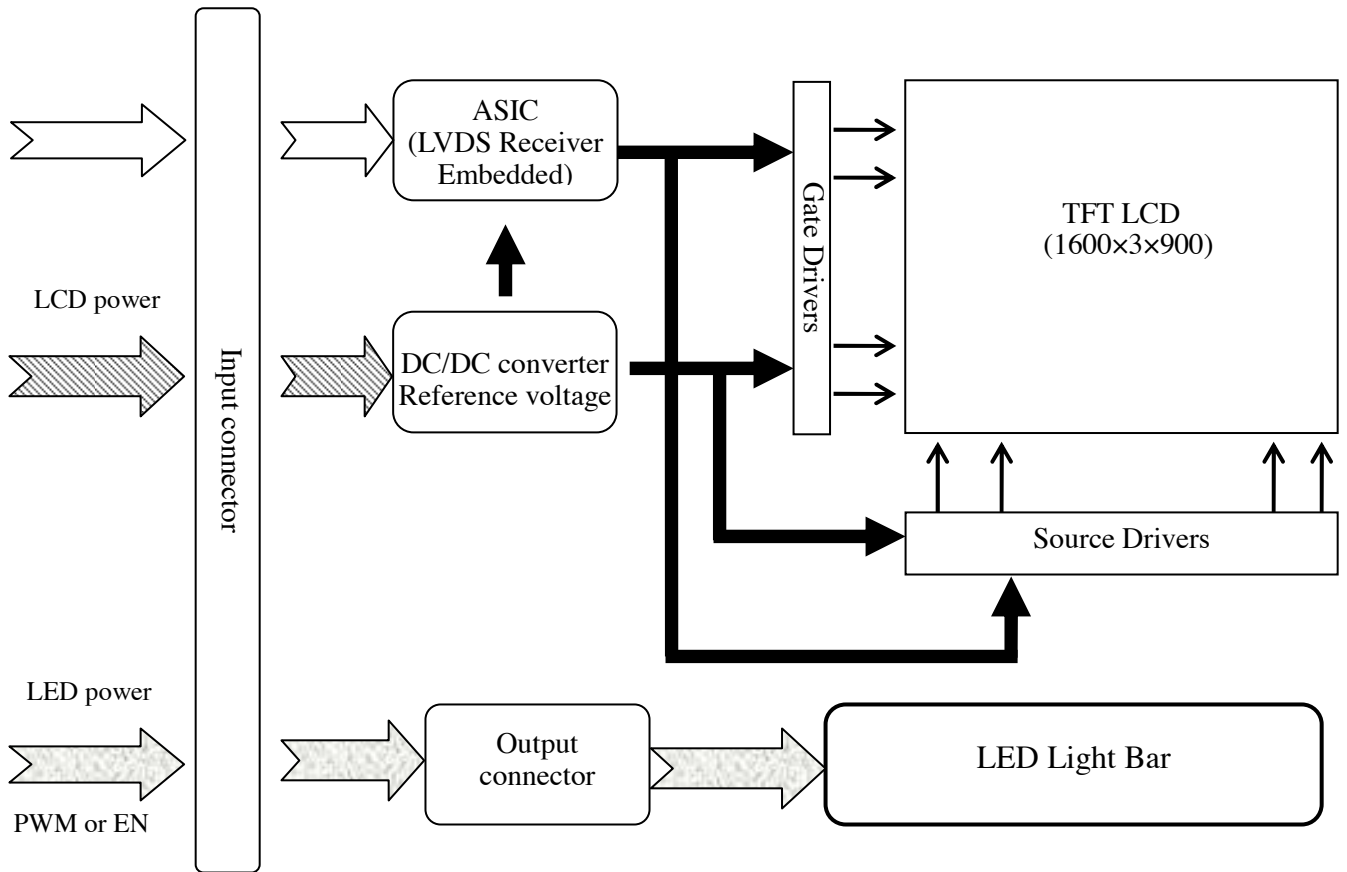

7. MECHANICAL SPECIFICATION

(1) Front side

The tolerance, not show in the figure, is ± 0.5 mm.

[Unit : mm]

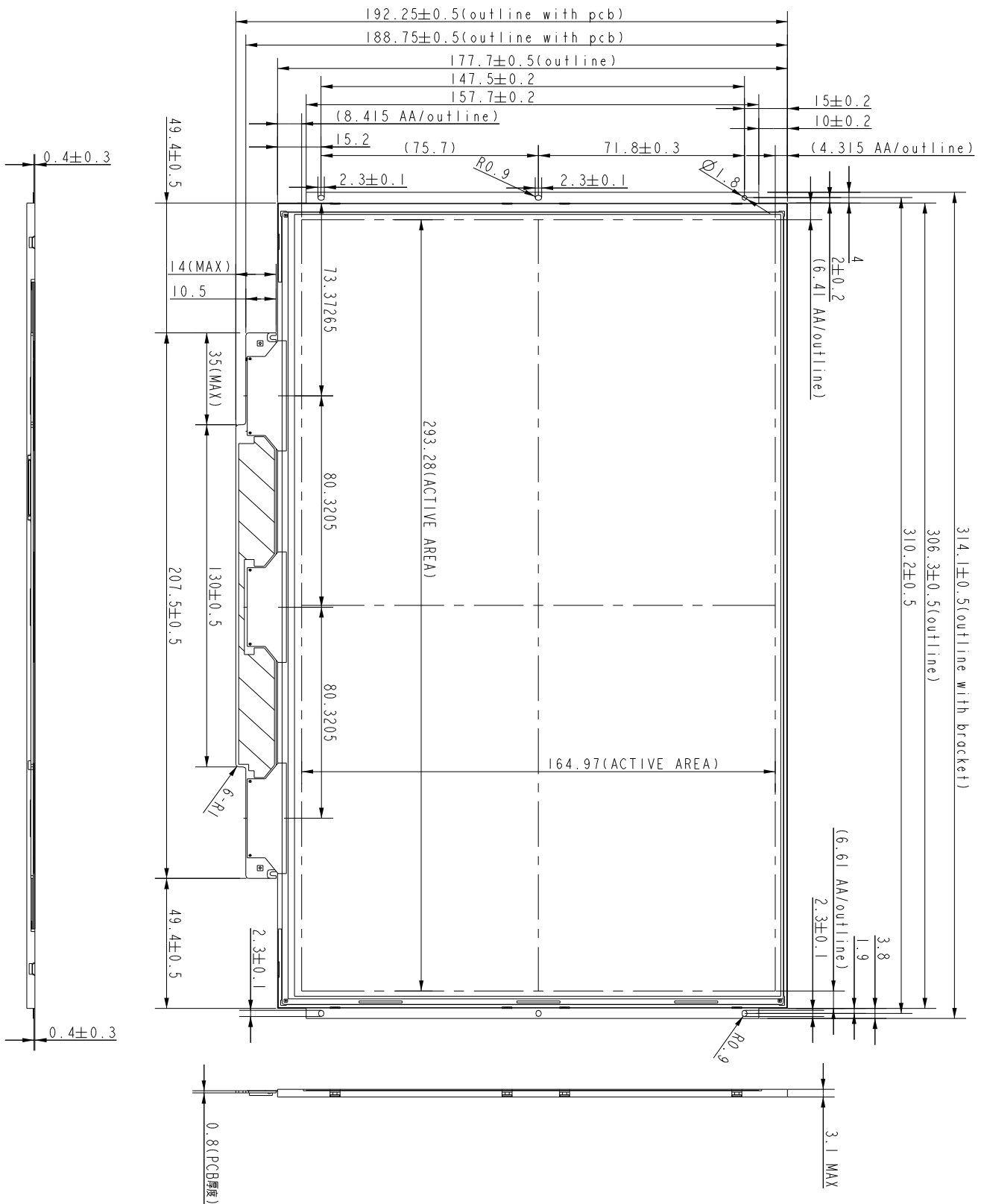

(2) Rear side

The tolerance, not show in the figure, is ± 0.5 mm.

[Unit : mm]

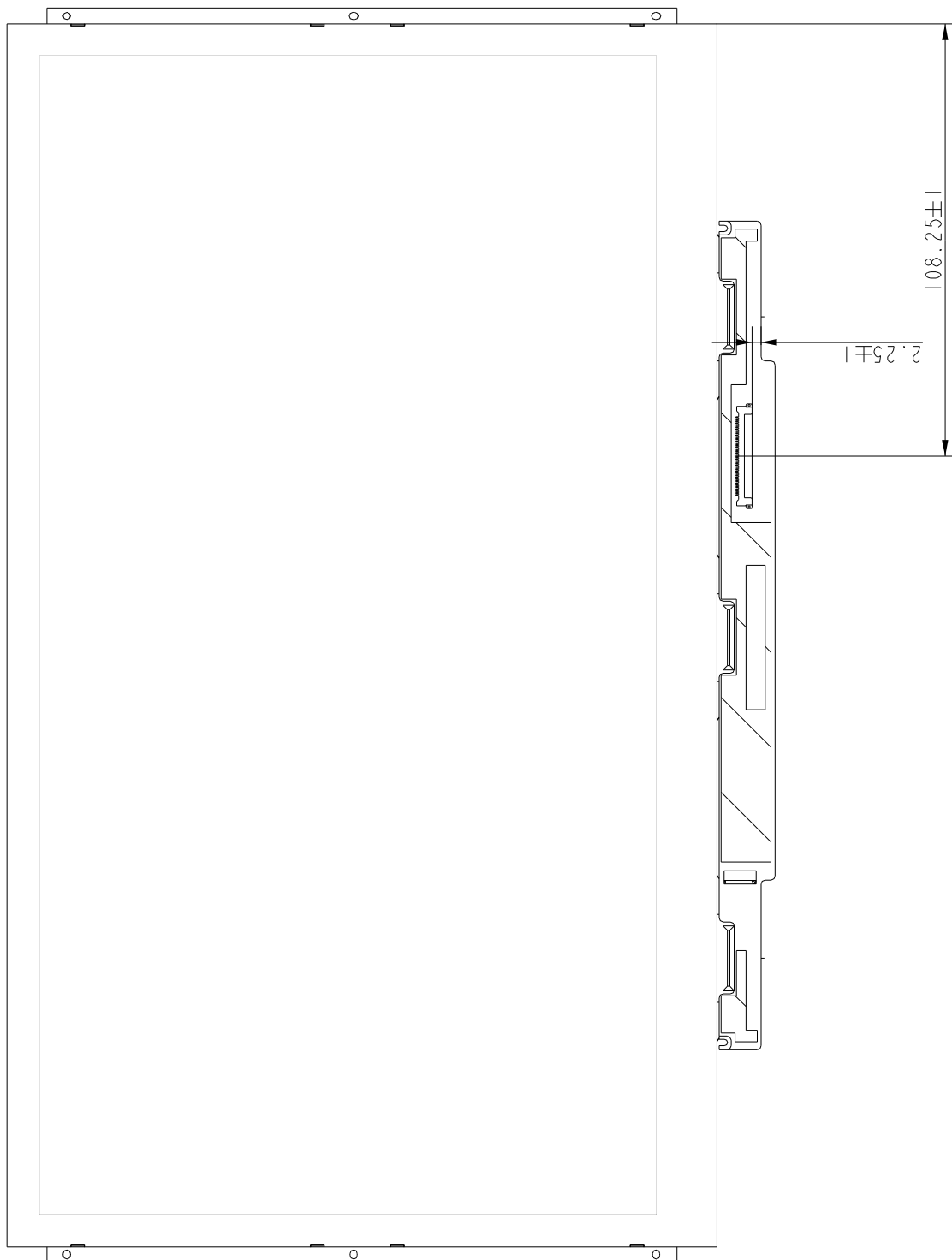

8. OPTICAL CHARACTERISTICS

Ta=25°C , VDD=3.3V

| ITEM | SYMBOL | CONDITION | MIN | TYP | MAX | UNIT | NOTE | |
|------------------------------|------------|---------------------------|---------------------------|--------|-------|-------------------|--------|-----|
| Contrast Ratio | CR | $\theta = \psi = 0^\circ$ | 400 | 500 | | -- | *1) 2) | |
| Luminance (5P) | L | $\theta = \psi = 0^\circ$ | 260 | 300 | | cd/m ² | *1) 3) | |
| Uniformity(5P) | ΔL | $\theta = \psi = 0^\circ$ | 80 | | | % | *1) 3) | |
| Response Time | Tr | $\theta = \psi = 0^\circ$ | | 6 | 9 | ms | *5) | |
| | Tf | $\theta = \psi = 0^\circ$ | | 10 | 16 | ms | *5) | |
| Cross Talk | CT | $\theta = \psi = 0^\circ$ | | | 1 | % | *6) | |
| View Angle | Horizontal | ψ | $CR \geq 10$ | 40/-40 | | | ° | *4) |
| | Vertical | θ | | 15/-30 | | | ° | *4) |
| Color Temperature Coordinate | W | X | $\theta = \psi = 0^\circ$ | 0.293 | 0.313 | 0.333 | *3) | |
| | | Y | | 0.309 | 0.329 | 0.349 | | |
| | R | X | | 0.538 | 0.586 | 0.598 | | |
| | | Y | | 0.306 | 0.336 | 0.366 | | |
| | G | X | | 0.318 | 0.348 | 0.378 | | |
| | | Y | | 0.540 | 0.570 | 0.600 | | |
| B | X | 0.132 | 0.162 | 0.192 | | | | |
| | Y | 0.091 | 0.121 | 0.153 | | | | |
| Gamut | | $\theta = \psi = 0^\circ$ | 42% | 45% | | | | |
| Gamma | γ | GL | 2.0 | 2.2 | 2.4 | | *7) | |

Color coordinate and color gamut are measured by SRUL1R, response time is measured by TRD-100, and all the other items are measured by BM-5A (TOPCON). All these items are measured under the dark room condition (no ambient light).

Measurement Condition: IL= 20mA (each LED)

Definition of these measurement items is as follows:

*1) Setup of Measurement Equipment

The LCD module should be turn-on to a stable luminance level to be reached. The measurement should be executed after lighting Backlight for 20 minutes and in a dark room.

*2) Definition of Contrast Ratio

CR=ON (White) Luminance/OFF (Black) Luminance

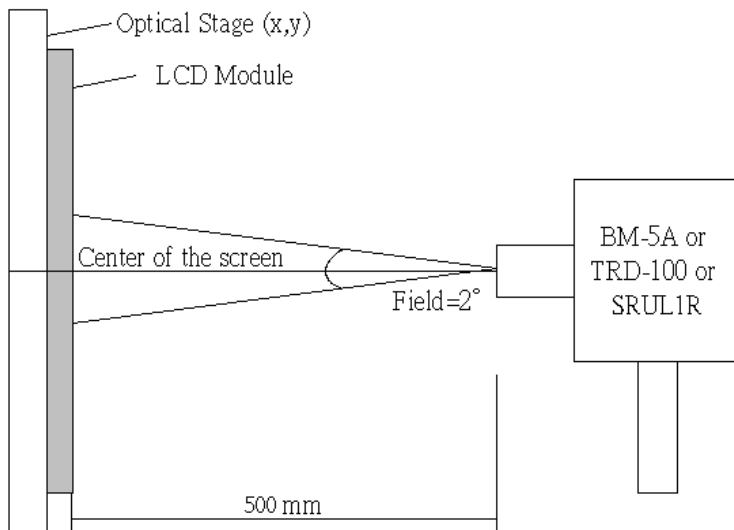

***3) Definition of Luminance and Luminance uniformity**

Central luminance: The white luminance is measured at the center position "5" on the screen, see Fig.1 below.

5P Luminance (AVG): The white luminance is measured at measuring points 5、10、11、12、13, see Fig.1 below.

5P Uniformity: $\Delta L = (L_{min} / L_{max}) \times 100\%$

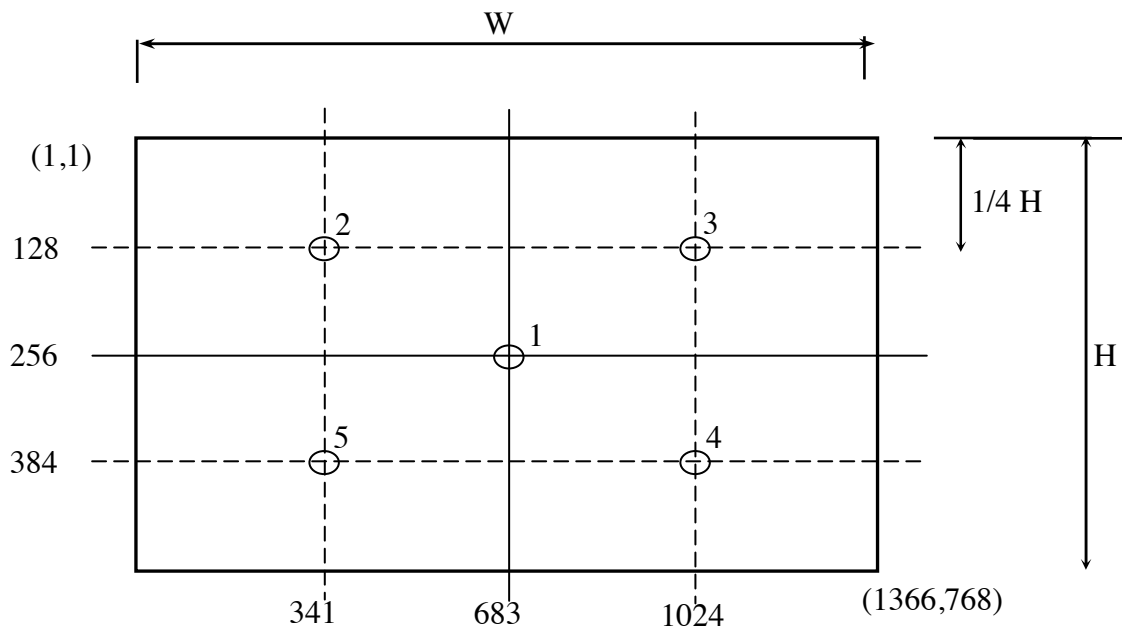

***4) Definition of view angle(θ , ψ)**

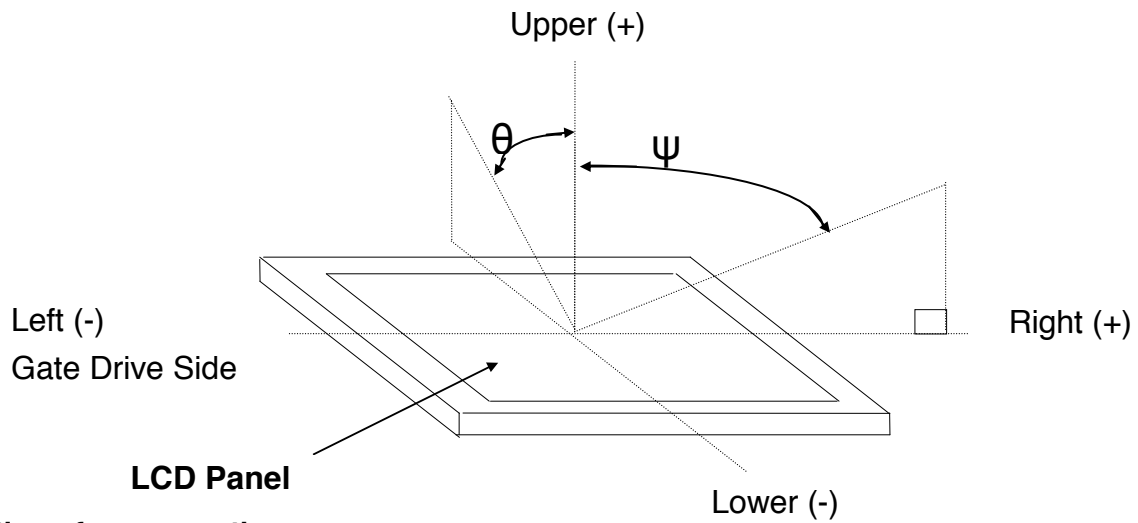

***5) Definition of response time**

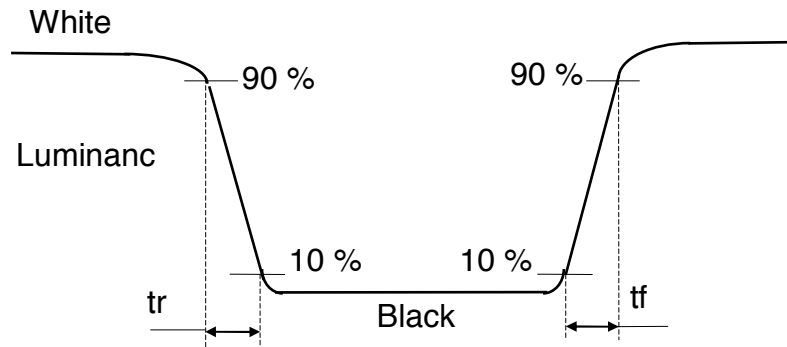

***6) Crosstalk Modulation Ratio:**

$$CT = | Y_B - Y_A | / Y_{Ax} \times 100\%$$

Y_A , Y_B measure position and definition

Y_A means luminance at gray level 31(exclude gray level 0 pattern)

Y_B means luminance at gray level 31(include gray level 0 pattern)

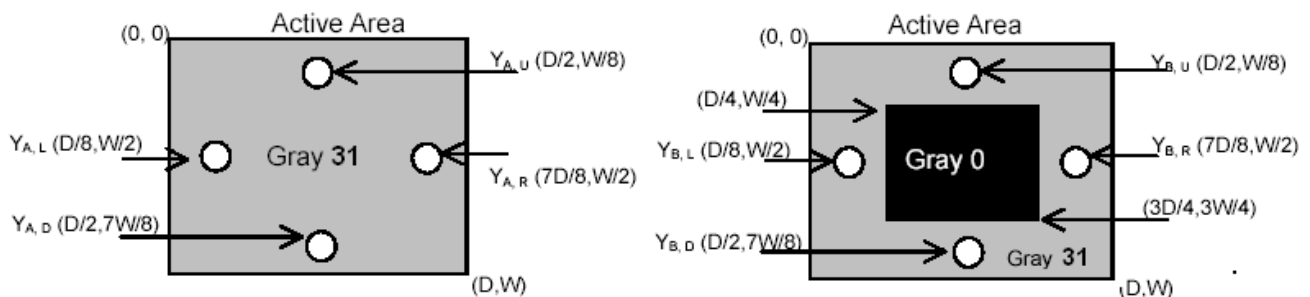

***7) Definition of Gamma (VESA)**

Based on Customer Sample, take the average value as a standard center value and the variation range of gamma value caused by loop voltage error should be between +/- 0.2. the bellow figure shows how to obtain the gamma curve and γ (from gray level: 0、4、8-----60、63).

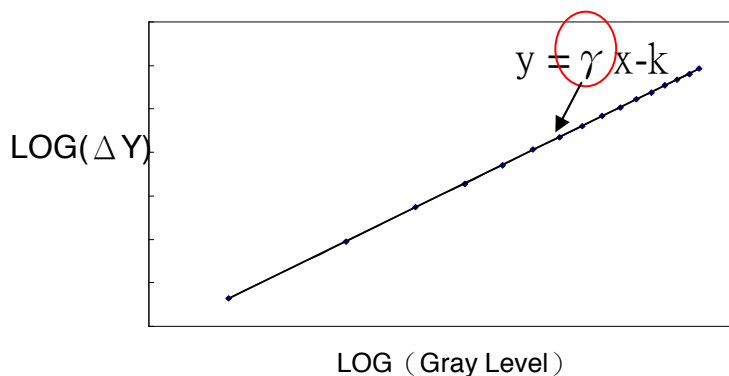

9. RELIABILITY TEST CONDITIONS

(A) Temperature 、 Humidity and Pressure

| TEST ITEMS | CONDITIONS |
|--|---|
| High Temperature Operation | 50° C ; 250Hrs |
| High Temperature Storage | 65° C ; 250Hrs |
| High Temperature High Humidity Operation | 40° C ; 95% RH ; 250Hrs |
| High Temperature High Humidity Storage | 60° C ; 95% RH ; 48 Hrs |
| Low Temperature Operation | 0° C ; 250 Hrs |
| Low Temperature Storage | -25° C ; 250 Hrs |
| Thermal Shock | -40° C (30 Mins)~65° C (30 Mins) , 100 CYCLE |
| Low Temperature Low Pressure Storage | 0° C 、 260hPa 、 24 Hrs |

(B) Shock & Vibration

| TEST ITEMS | CONDITIONS |
|------------------------------|--|
| Shock (Non-Operation) | Shock level : 2058m/s ² (210G), Waveform : half sinusoidal wave, 2ms, 6 axis (± X, ± Y, ± Z) per cycle |
| Vibration (Non-Operation) | Vibration level : 14.7m/s ² (1.5G), sinusoidal wave (each x, y, z axis : 1hr, total 3hrs) Frequency range : 5 ~ 500 Hz Sweep speed : 0.5 Octave/min. |

(C) ESD

| | Surface discharge (Panel display area 、 Frame) | | Electric capacity of Connector |
|---------------------|---|------------|-----------------------------------|
| | Contact | Air | Contact |
| Capacity | 150 pF | 150 pF | 200 pF |
| Resistance | 330 Ω | 330 Ω | 0 Ω |
| Voltage | ±8kV | ±8kV/±15kV | ±250 V |
| Interval | 1 sec | 1 sec | 1 sec |
| Times(single point) | 25 | 25 | 1 |

(D) MTBF without B/L : 200,000 Hrs(min) lifetime.

(E) Judgment standard

The judgment of the above test should be made as follow:

Pass : Normal display image with no obvious non-uniformity and no line defect.

Partial transformation of the module parts should be ignored.

Fail : No display image, obvious non-uniformity, or line defects.

10. HANDLING PRECAUTIONS FOR TFT-LCD MODULE

Please pay attention to the followings in handling- TFT-LCD products;

10.1 ASSEMBLY PRECAUTION

- (1) Please use the mounting hole on the module side in installing and do not beading or wrenching LCD in assembling. And please do not drop, bend or twist LCD module in handling.
- (2) Please design display housing in accordance with the following guidelines.
 - Housing case must be destined carefully so as not to put stresses on LCD all sides and not to wrench module. The stresses may cause non-uniformity even if there is no non-uniformity statically.
 - Keep sufficient clearance between LCD module back surface and housing when the LCD module is mounted. Approximately 1.0 mm of the clearance in the design is recommended taking into account the tolerance of LCD module thickness and mounting structure height on the housing.
 - When some parts, such as, FPC cable and ferrite plate, are installed underneath the LCD module, still sufficient clearance is required, such as 0.5mm. This clearance is, especially, to be reconsidered when the additional parts are implemented for EMI countermeasure.
 - Design the inverter location and connector position carefully so as not to give stress to lamp cable, or not to interface the LCD module by the lamp cable.
 - Keep sufficient clearance between LCD module and the others parts, such as inverter and speaker so as not to interface the LCD module. Approximately 1.0mm of the clearance in the design is recommended.
- (3) Please do not push or scratch LCD panel surface with any-thing hard. And do not soil LCD panel surface by touching with bare hands. (Polarizer film, surface of LCD panel is easy to be flawed.)
- (4) Please do not press any parts on the rear side such as source TCP, gate TCP, control circuit board and FPCs during handling LCD module. If pressing rear part is unavoidable, handle the LCD module with care not to damage them.
- (5) Please wipe out LCD panel surface with absorbent cotton or soft clothe in case of it being soiled.
- (6) Please wipe out drops of adhesives like saliva and water on LCD panel surface immediately. They might damage to cause panel surface variation and color change.
- (7) Please do not take a LCD module to pieces and reconstruct it. Resolving and reconstructing modules may cause them not to work well.
- (8) Please do not touch metal frames with bare hands and soiled gloves. A color change of the metal frames can happen during a long preservation of soiled LCD modules.
- (9) Please pay attention to handling lead wire of backlight so that it is not tugged in connecting with inverter.

10.2 OPERATING PRECAUTIONS

- (1) Please be sure to turn off the power supply before connecting and disconnecting signal input cable.
- (2) Please do not change variable resistance settings in LCD module. They are adjusted to the most suitable value. If they are changed, it might happen LCD does not satisfy the characteristics specification.
- (3) Please consider that LCD backlight takes longer time to become stable of radiation characteristics in low temperature than in room temperature.
- (4) A condensation might happen on the surface and inside of LCD module in case of sudden change of ambient temperature.

- (5) Please pay attention to displaying the same pattern for very long time. Image might stick on LCD. If then, time going on can make LCD work well.
- (6) Please obey the same caution descriptions as ones that need to pay attention to ordinary electronic parts.

10.3 PRECAUTIONS WITH ELECTROSTATICS

- (1) This LCD module use CMOS-IC on circuit board and TFT-LCD panel, and so it is easy to be affected by electrostatics. Please be careful with electrostatics by the way of your body connecting to the ground and so on.
- (2) Please remove protection film very slowly on the surface of LCD module to prevent from electrostatics occurrence.

10.4 STORAGE PRECAUTIONS

- (1) When you store LCDs for a long time, it is recommended to keep the temperature between 0°C ~40°C without the exposure of sunlight and to keep the humidity less than 90%RH.
- (2) Please do not leave the LCDs in the environment of high humidity and high temperature such as 60°C and 90%RH.
- (3) Please do not leave the LCDs in the environment of low temperature(below -20°C.)

10.5 SAFETY PRECAUTIONS

- (1) When you waste LCDs, it is recommended to crush damaged or unnecessary LCDs into pieces and wash them off with solvents such as acetone and ethanol, which should later be burned.
- (2) If any liquid leaks out of a damaged-glass cell and comes in contact with the hands, wash off thoroughly with soap and water.

10.6 OTHERS

- (1) A strong incident light into LCD panel might cause display characteristic changing inferior because of polarizer film, color filter, and other materials becoming inferior. Please do not expose LCD module direct sunlight and strong UV rays.
- (2) Please pay attention to a panel side of LCD module not to contact with other materials in preserving it alone.
- (3) For the packaging box, please pay attention to the followings:
 - Packaging box and inner case for LCD are designed to protect the LCDs from the damage or scratching during transportation. Please do not open except picking LCDs up from the box.
 - Please do not pile them up more than 3 boxes. (They are not designed so.) And please do not turn over.
 - Please handle packaging box with care not to give them sudden shock and vibrations. And also please do not throw them up.
 - Packing box and inner case for LCDs are made of cardboard. So please pay attention not to get them wet. (Such like keeping them in high humidity or wet place can occur getting them wet.)