



Chunghwa Picture Tubes, Ltd.

Technical Specification

To :
Date : 2005/07/22

TFT LCD (Lead Free)
CLAA154WA01Q

ACCEPTED BY :

APPROVED BY	CHECKED BY	PREPARED BY

Prepared by : TFT-LCD Product Planning Management General Division

CHUNGHWA PICTUER TUBES, LTD.

1127 Hopin Rd., Padeh, Taoyuan, Taiwan 334, R.O.C.
TEL: +886-3-3675151 FAX: +886-3-377-3001

Doc.No:	CLAA154WA01Q-STUDIO-2005/07/22	Issue Date:	2005/07/22
---------	--------------------------------	-------------	------------

CONTENTS

NO.	ITEM	Page
1	OVERVIEW	3
2	ABSOLUTE MAXIMUM RATINGS	4
3	ELECTRICAL CHARACTERISTICS	5
4	CONNECTOR INTERFACE PIN & FUNCTION	10
5	INTERFACE TIMING CHART	11
6	BLOCK DIAGRAM	14
7	MECHANICAL SPECIFICATION	15
8	OPTICAL CHARACTERISTICS	17
9	RELIABILITY TEST CONDITIONS	21
10	HANDLING PRECAUTIONS FOR TFT-LCD MODULE	22

Studio Technology Co., Ltd

1. OVERVIEW

CLAA154WA01Q is 15.4" color TFT-LCD (Thin Film Transistor Liquid Crystal Display) module composed of LCD panel, LVDS driver ICs, control circuit and backlight. By applying 6 bit digital data, 1280×800, 262K color images are displayed on the 15.4 inch diagonal screen. Interface of data and control signals is Typ. 68.9 MHz digital. General specification are summarized in the following table :

ITEM	SPECIFICATION
Display Area (mm)	331.2 (H)×207.0 (V) (15.4-inch diagonal)
Number of Pixels	1280 ×3(H)×800(V)
Pixel Pitch (mm)	0.25875(H)×0.25875(V)
Color Pixel Arrangement	RGB vertical stripe
Display Mode	Normally white TN
Number of Colors	262,144
Optimum Viewing Angle	6 o'clock
Brightness (cd/m ²)	250cd/m ² (center),230 cd/m ² (5 point)@6mA(Typ.)
Viewing Angle(H/V)	-60°~60° / -55°~45°
Consumption of Power (W)	5.7W (Typ.) \ 6.5W(Max.) w/o inverter LCM circuit 1.5W(typ) B/L input 4.2W(typ)
Module Size (mm)	344.5(W)×222.5(H)×6.2(D) (max)
Module Weight (g)	570(Typ)
Backlight Unit	CCFL, 1 tube
Surface Treatment	Anti-glare

The LCD Products listed on this document are not suitable for use of aerospace equipment, submarine cables, and nuclear reactor control system and life support systems. If customers intend to use these LCD products for above application or not listed in "Standard" as follows, please contact our sales people in advance.

Standard: Computer, Office equipment, Communication equipment, Test and Measurement equipment, Machine tool, Industrial robot, Audio and Visual equipment, Other consumer products.

2. ABSOLUTE MAXIMUM RATINGS

The following are maximum value, which if exceeded, may cause faulty operation or damage to the unit.

ITEM	SYMBOL	MIN.	MAX.	UNIT	REMARK
Power Supply Voltage for LCD	VCC	0	4.0	V	
Lamp voltage	VL	650	945	Vrms	
Lamp current	IL	3	6.5	mA	*1)*2)
Lamp frequency	FL	40	80	kHz	
Operation Temperature	Top	0	50	°C	*3)*4)*5)*6)
Storage Temperature	Tstg	-20	60	°C	*3)*4)*5)
Delayed Discharge Time	TD	--	1	sec	*7)

【Note】

- *1) Product life-time relate to the lamp current, please operate following statement ((B)Back light system) at page 9.
- *2) When lamp current over the definition of absolute max. value , life-time of the product will decay rapidly or operate unusual.
- *3) The relative temperature and humidity range are as below sketch, 90%RH Max. ($T_a \leq 40^\circ\text{C}$)
- *4) The maximum wet bulb temperature $\leq 39^\circ\text{C}$ ($T_a > 40^\circ\text{C}$) and without dewing.
- *5) If users use the product out off the environment operation range (temperature and humidity) , it will concern for visual quality.
- *6) The product must work at operation temperature range and the surface temperature of the panel's center point must be lower then 60°C .
- *7) Delay discharge time(TD) test condition: starting lamp voltage=1650Vrms.(please follow statement ((B)Back light system) at page 9.
Before test TD, lamp should be start at least 1 min at the typical value of lamp current and then place the panel at room temp. ($25 \pm 2^\circ\text{C}$) exceed 24hrs. Measuring the TD value at the same condition (starting lamp voltage) in dark room.

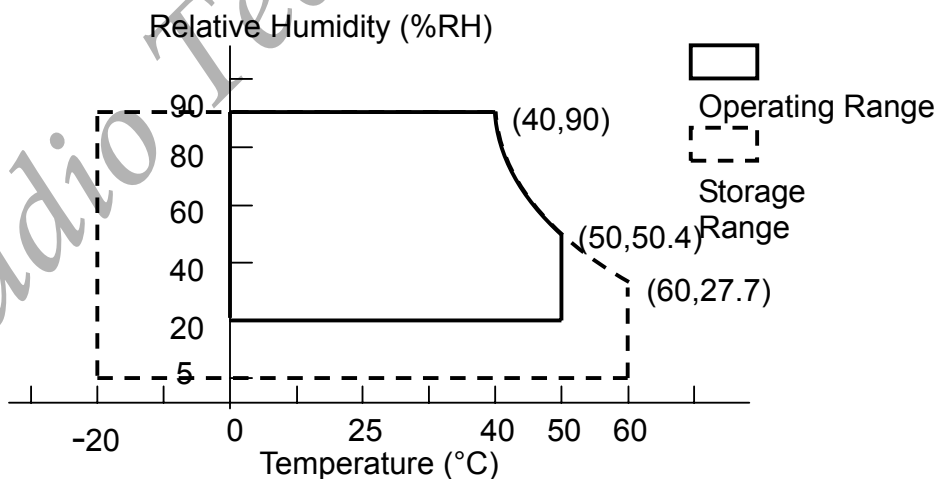

3. ELECTRICAL CHARACTERISTICS

3.1 TFT LCD

Ta=25°C

ITEM	SYMBOL	MIN	TYP	MAX	UNIT	REMARK	
LCD POWER VOLTAGE	VCC	3.0	3.3	3.6	V	*1)	
LCD POWER CURRENT	ICC	-	400	600	mA	*2)	
Rush CRRENT	Irush	-	-	2	A	*4)	
LOGIC INPUT VOLTAGE (LVDS: IN+,IN-) *3)	INPUT VOLTAGE	VIN	0	-	VCC	V	
	COMMON VOLTAGE	VCM	0.6	1.15	1.7	V	
	DIFFERENTIAL INPUT VOLTAGE	VID	250	350	450	mV	
	THRESHOLD VOLTAGE (HIGH)	VTH	-	-	100	mV	FOR VCM=+1.2V
	THRESHOLD VOLTAGE (LOW)	VTL	-100	-	-	mV	
DIFFERENTIAL INPUT VOLTAGE TOLERANCE	ΔVID	-	-	35	mV		
COMMON VOLTAGE TOLERANCE	ΔVCM	-	-	35	mV		

[Note]

*1)Power sequence :

- t1 ≤ 10ms
- 0.01 ms < t2 ≤ 50 ms
- 0.01 ms < t3 ≤ 50 ms
- 0.01 ms < t4 ≤ 10 ms
- 1 sec ≥ t5
- 200 ms ≥ t6
- 200 ms ≥ t7

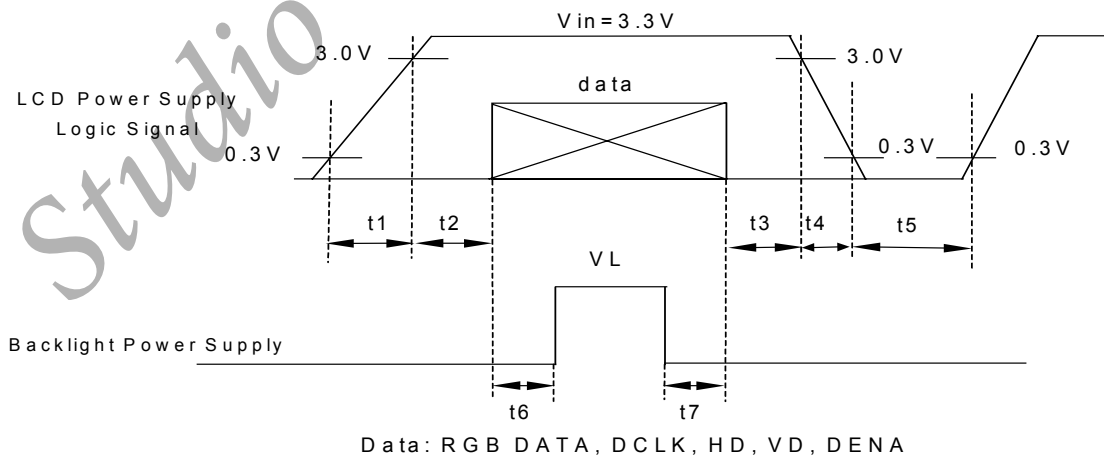

VCC-dip state

(1)When 3.0 > VCC ≥ 2.7V , td ≤ 10 ms

(2)When $VCC < 2.7V$,if it works abnormal that must reset the power. VCC dip conditions should follow VCC turn on conditions.

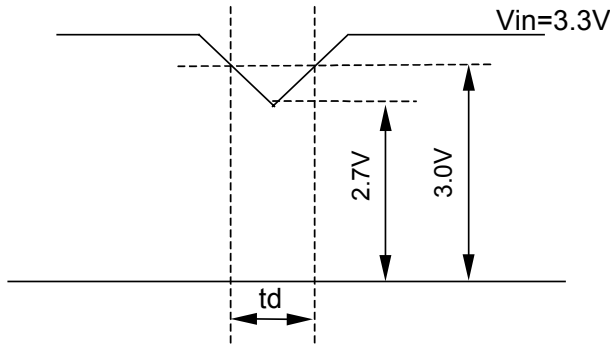

*2) Power current :

(1)Typical value : $VCC=3.3 V$, $f_v=60 Hz$ $f_H=49.31 kHz$, $f_{CLK}=68.9 MHz$



64-Gray :
0 ~ 63 Gray

(2)Max. value :

$VCC=3.3 V$, $f_v=60 Hz$ $f_H=49.31 kHz$, $f_{CLK}=68.9 MHz$

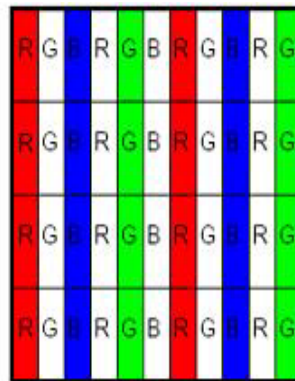
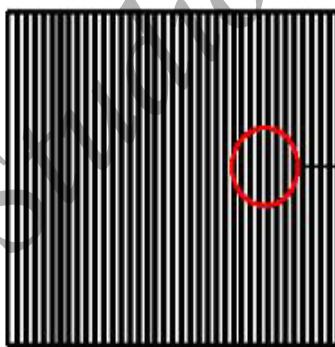

*3) LVDS signal definite :

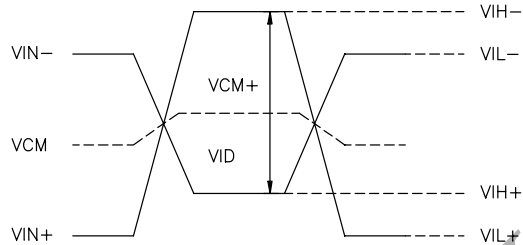
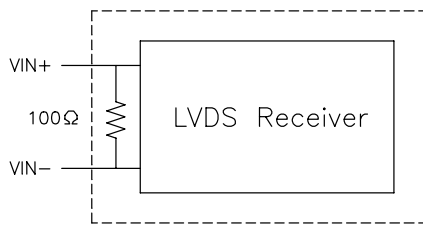

$$VID = VIN_+ - VIN_-$$

$$\Delta VCM = |VCM_+ - VCM_-|$$

$$\Delta VID = |VID_+ - VID_-|$$

$$VID_+ = |VIH_+ - VIL_-|$$

$$VID_- = |VIL_+ - VIH_-|$$

$$VCM = (VIN_+ + VIN_-)/2$$

$$VCM_+ = (VIH_+ + VIH_-)/2$$

$$VCM_- = (VIL_+ + VIL_-)/2$$

VI N+ : Positive differential DATA & CLK Input
 VI N- : Negative differential DATA & CLK Input

*4) Irush measurement condition :

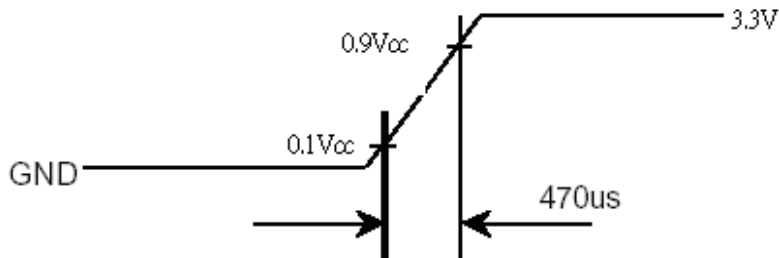
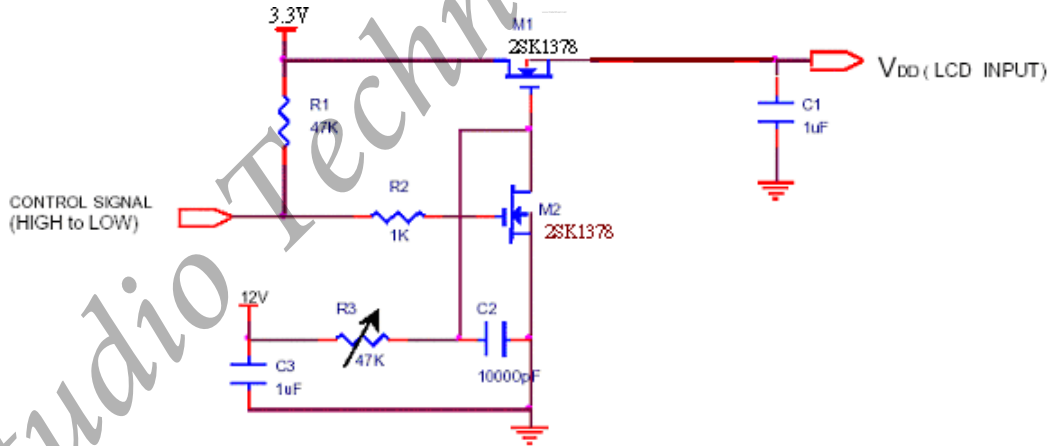

3.2 Back light*1)

3.2.1 Electrical characteristics :

ITEM	SYMBOL	MIN	TYP	MAX	UNIT	Remark
Lamp Voltage	VL	612	730	803	Vrms	IL=6.0mA
Lamp Current	IL	5.5	6.0	6.5	mArms	*2)
Inverter Frequency	FI	50	--	60	kHz	*3)
Starting Lamp Voltage *5)	VS	1460	--	--	Vrms	Ta=25°C
		1650	--	--	Vrms	Ta=0°C

3.2.2 Lamp life time

ITEM	IL at 2.0 mA	IL at 6.0 mA	IL at 6.5 mA	UNIT	REMARK
LAMP LIFE-TIME (LT)	Min. 10,000	Min. 10,000	Min. 10,000	hr	Continuous Operation*4)
Turn-on and turn-off Operation	--	Min.100,000	--	time	Test condition *5)

【Note】

*1)Inverter measure device : SUMIDA/ Mode : IV11145T

Lamp frequency of inverter may produce interference with horizontal synchronous frequency, and this may cause horizontal beat on the display. Therefore, please adjust lamp frequency, and keep inverter as far from module as possible or use electronic shielding between inverter and module to avoid the interference.

The degrees of unbalance : $< 10\%$
 The ratio of wave height : $< \sqrt{2} \pm 10\%$

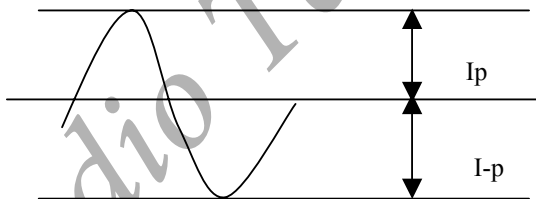

The degrees of unbalance = $(Ip - I-p) / Irms * 100(\%)$
 The ratio of wave height = $Ip(\text{or } I-p) / Irms$

Ip: lamp current high side peak, I-p: lamp current low side peak

*2) Measure method of lamp current: Galvanometer connect to low voltage

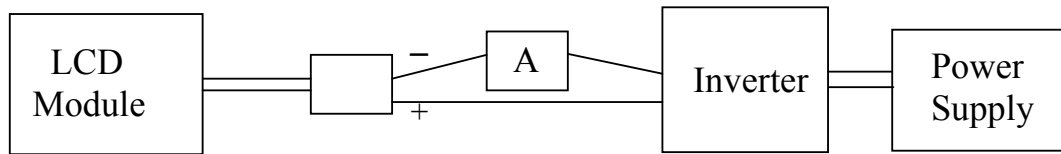

*3) Inverter Frequency

- a. At this frequency range, electrical and optical characteristics could keep in $\pm 10\%$ range(except color coordinate).
- b. Electrical and optical characteristics will display well at 50~60 kHz frequency.
- c. It would not damage the lifetime and reliability of the panel at 50~80 kHz frequency.
- d. Lamp frequency of inverter may produce interference with horizontal synchronous frequency, and this may cause horizontal beat on the display. Therefore, please adjust lamp frequency, and keep inverter as far from module as possible or use electronic shielding between inverter and module to avoid the interference.

*4) Definition of the lamp life time:

- a. Luminance (center point) reduced to 50% of the initial value.
- b. When starting lamp voltage over 130% of initial V_s value at 25°C.

*5) The condition of Turn-on and Turn-off operation is as below:

- a. Frequency is 10 sec.(on)/10 sec.(off) at 6mA lamp current.
- b. The variation of color coordinate of lamp must smaller than ± 0.03
- c. Starting lamp voltage should not exceed 130% of the initial value.
- d. Lamp luminance must grater then 50% of the initial value at 10 thousand times

Studio Technology Co., Ltd

4.Connector Interface PIN & Function *1)*2)

4.1 CN1(Interface signal)

Outlet connector: FI-XB30SL-HF10 (JAE)

Link connector: FI-X30H (JAE, Link Type)

Pin No.	SYMBOL	Function
1	Vss	Ground
2	Vin	+3.3V
3	Vin	+3.3V
4	V_EDID	DDC 3.3V Power
5	NC	VCOM test provided , but customer-end unused (open) ; No connect
6	CLK_EDID	DDC Clock
7	DATA_EDID	DDC Data
8	R0N	minus signal of channel 0(LVDS)
9	R0P	plus signal of channel 0(LVDS)
10	Vss	Ground
11	R1N	minus signal of channel 1(LVDS)
12	R1P	plus signal of channel 1(LVDS)
13	Vss	Ground
14	R2N	minus signal of channel 2(LVDS)
15	R2P	plus signal of channel 2(LVDS)
16	Vss	Ground
17	RCLKN	minus signal of clock channel (LVDS)
18	RCLKP	plus signal of clock channel (LVDS)
19	Vss	Ground
20	NC	No connect
21	NC	No connect
22	NC	No connect
23	NC	No connect
24	NC	No connect
25	NC	No connect
26	NC	No connect
27	NC	No connect
28	NC	No connect
29	NC	No connect
30	NC	No connect

【Note】

*1) DDC: Display Data Requirements

*2) Refer to Data Mapping of page 7,8,9.

4.2 CN2 (Back light)

Backlight-side connector: BHSR-02VS-1 (JST)

5. INTERFACE TIMING CHART

5.1 LCD Input Signal Timing Chart

5.1.1 Horizontal Timing sequence

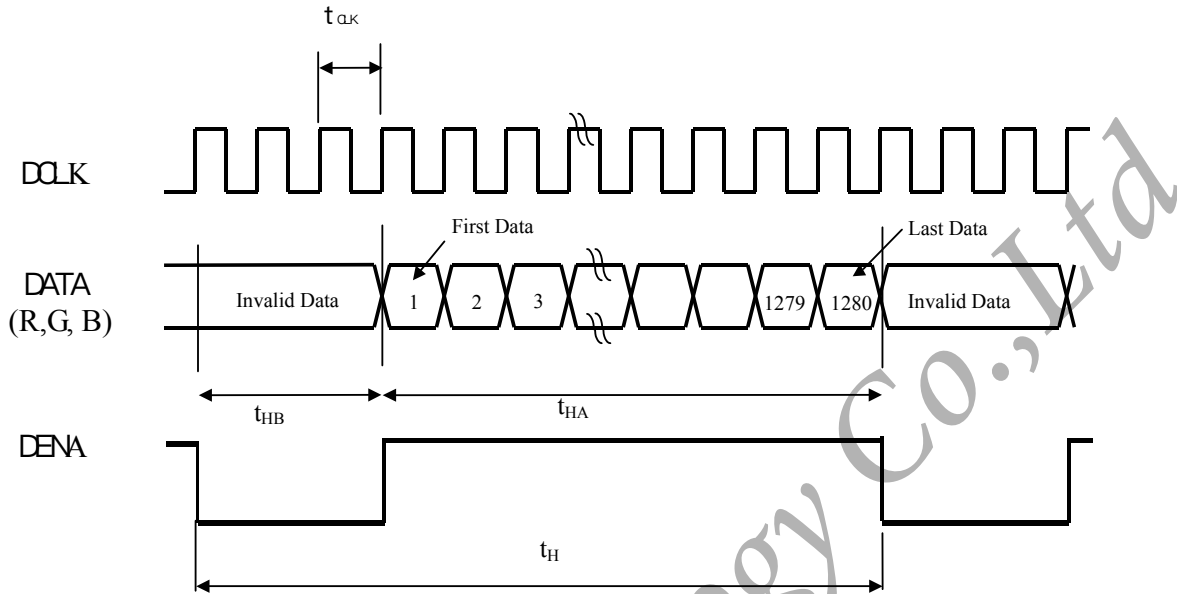

5.1.2 Vertical Timing sequence:

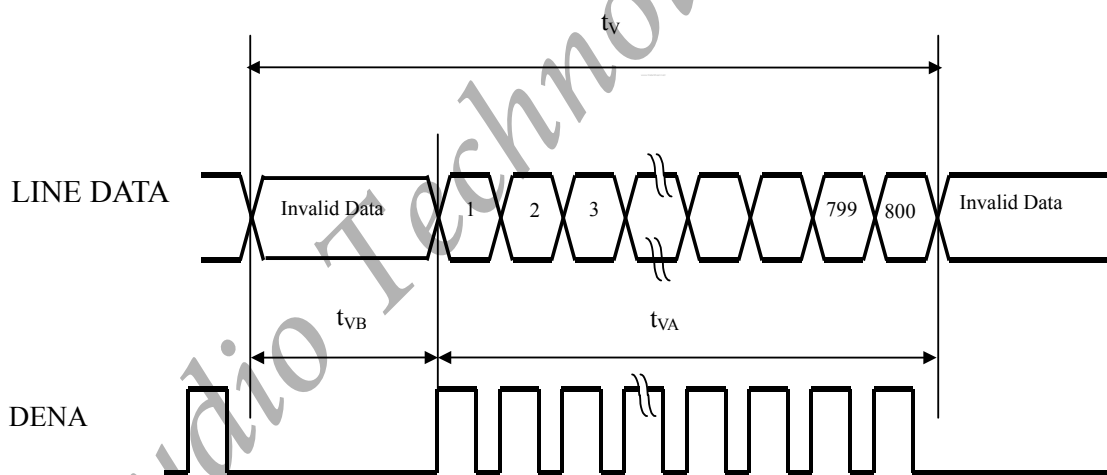

5.2 Timing Chart *1)*2)*3)

		ITEM	SYMBOL	MIN	TYP	MAX	UNIT
LCD input signal	DCLK	frequency	f_{CLK}	65.3	68.9	74.7	MHz
		period	t_{CLK}	15.3	14.5	13.3	ns
	DENA	Horizontal total Time	t_H	1344	1408	1500	t_{CLK}
		Horizontal Active Time	t_{HA}	1280	1280	1280	t_{CLK}
		Horizontal Blank Time	t_{HB}	64	128	220	t_{CLK}
		Vertical total Time	t_V	810	816	830	t_H
		Vertical Active Time	t_{VA}	800	800	800	t_H
		Vertical Blank Time	t_{VB}	10	16	30	t_H

【Note】

- *1) Frame rate is 60Hz (typ.).
- *2) DENA (DATA ENABLE) is usually positive value.
- *3) During the whole blank period, DCLK should keep input.

5.3 Color DATA Assignment

Color	Input Data	R DATA						G DATA						B DATA					
		R5	R4	R3	R2	R1	R0	G5	G4	G3	G2	G1	G0	B5	B4	B3	B2	B1	B0
		MS B					LS B	MS B					LS B	MS B					LS B
Basic Color	Black	0	0	0	0	0	0	0	0	0	0	0	0	0	0	0	0	0	0
	Red(63)	1	1	1	1	1	1	0	0	0	0	0	0	0	0	0	0	0	0
	Green(63)	0	0	0	0	0	0	1	1	1	1	1	1	0	0	0	0	0	0
	Blue(63)	0	0	0	0	0	0	0	0	0	0	0	0	1	1	1	1	1	1
	Cyan	0	0	0	0	0	0	1	1	1	1	1	1	1	1	1	1	1	1
	Magenta	1	1	1	1	1	1	0	0	0	0	0	0	1	1	1	1	1	1
	Yellow	1	1	1	1	1	1	1	1	1	1	1	1	0	0	0	0	0	0
	White	1	1	1	1	1	1	1	1	1	1	1	1	1	1	1	1	1	1
RED	RED(0)	0	0	0	0	0	0	0	0	0	0	0	0	0	0	0	0	0	0
	RED(1)	0	0	0	0	0	1	0	0	0	0	0	0	0	0	0	0	0	0
	RED(2)	0	0	0	0	1	0	0	0	0	0	0	0	0	0	0	0	0	0
	RED(62)	1	1	1	1	1	0	0	0	0	0	0	0	0	0	0	0	0	0
	RED(63)	1	1	1	1	1	1	0	0	0	0	0	0	0	0	0	0	0	0
Green	Green(0)	0	0	0	0	0	0	0	0	0	0	0	0	0	0	0	0	0	0
	Green(1)	0	0	0	0	0	0	0	0	0	0	0	1	0	0	0	0	0	0
	Green(2)	0	0	0	0	0	0	0	0	0	0	1	0	0	0	0	0	0	0
	Green(62)	0	0	0	0	0	0	1	1	1	1	1	0	0	0	0	0	0	0
	Green(63)	0	0	0	0	0	0	1	1	1	1	1	1	0	0	0	0	0	0
Blue	Blue(0)	0	0	0	0	0	0	0	0	0	0	0	0	0	0	0	0	0	0
	Blue(1)	0	0	0	0	0	0	0	0	0	0	0	0	0	0	0	0	0	1
	Blue(2)	0	0	0	0	0	0	0	0	0	0	0	0	0	0	0	0	1	0
	Blue(62)	0	0	0	0	0	0	0	0	0	0	0	0	1	1	1	1	1	0
	Blue(63)	0	0	0	0	0	0	0	0	0	0	0	0	1	1	1	1	1	1

【Note】

- (1) Definition of gray scale:
 Color(n) : n means level of gray scale .
 Larger n means brighter level.
- (2) Data : 1= High , 0 = Low

6. BLOCK DIAGRAM

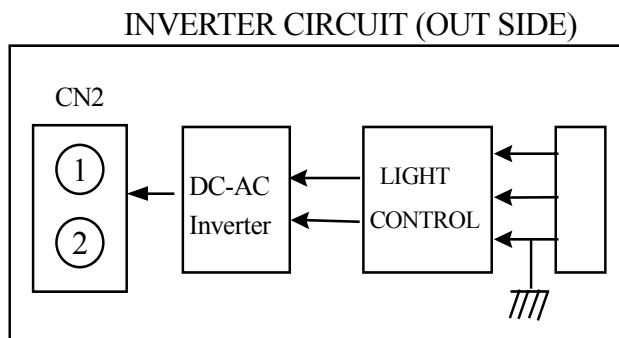
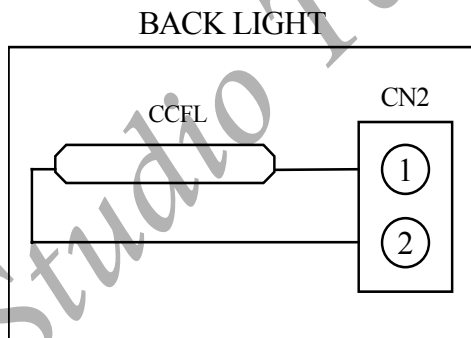
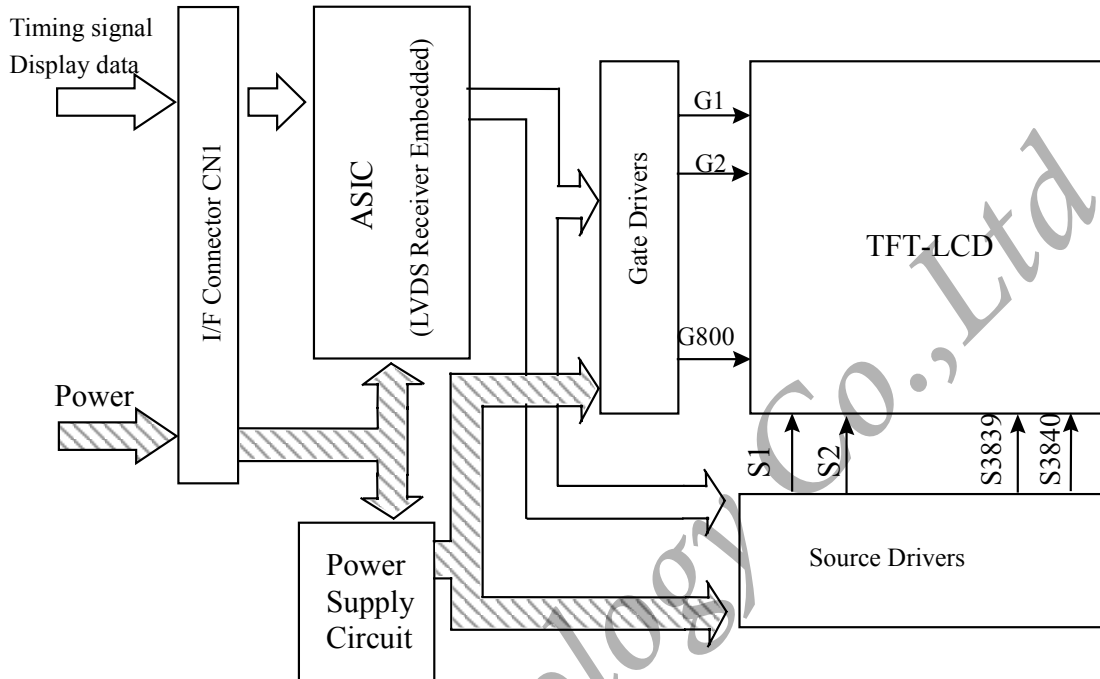

7.2 Rear side

Tolerance is $\pm 0.5\text{mm}$ unless noted

[Unit : mm]

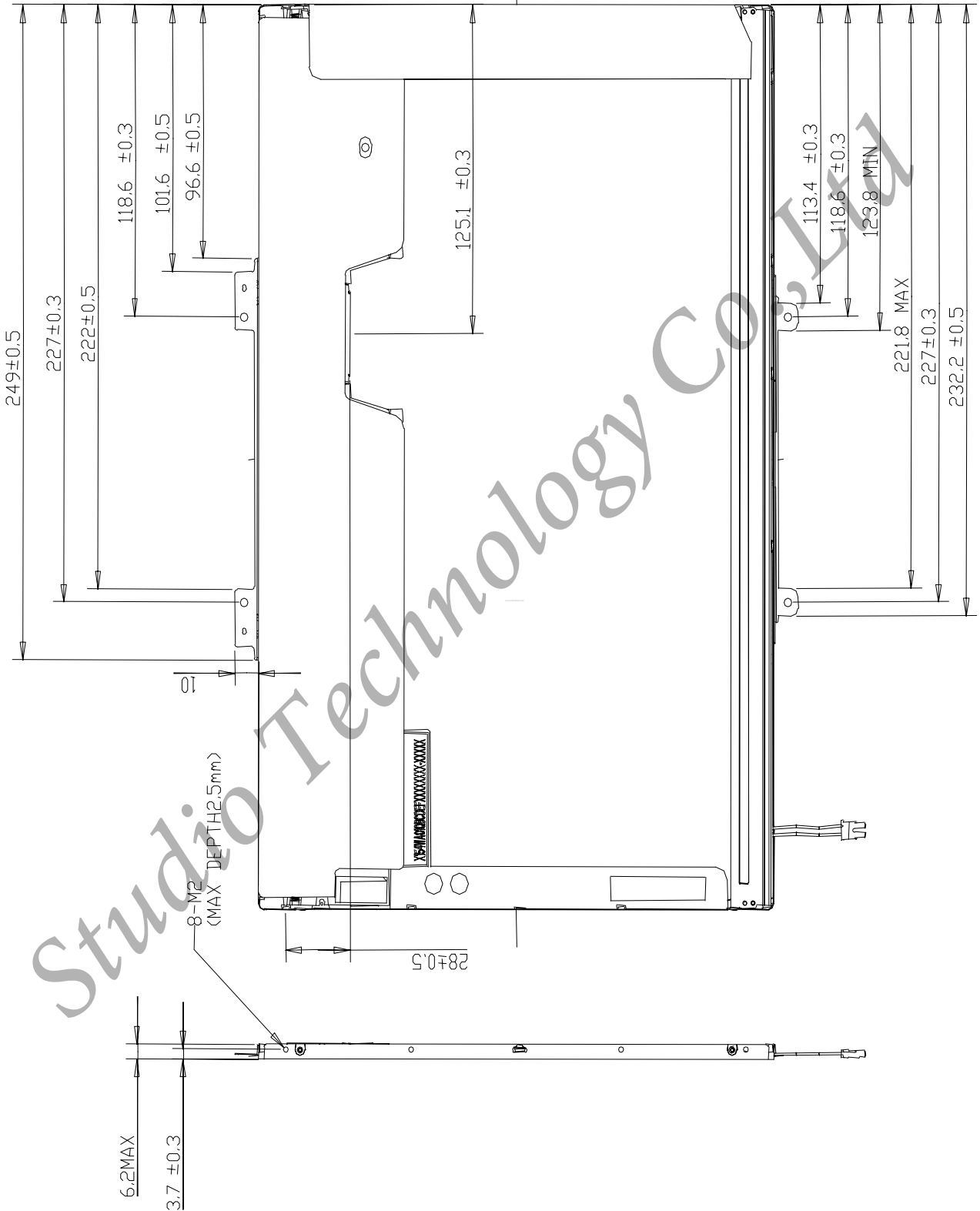

8. OPTICAL CHARACTERISTICS

Ta=25°C , VCC=3.3V

ITEM		SYMBOL	CONDITION	MIN.	TYP.	MAX.	UNIT
Contrast Uniformity		CR	$\theta = \psi = 0^\circ$	500	600		--
Luminance (CEN)		L	$\theta = \psi = 0^\circ$	220	250		cd/m ²
Luminance (5P)		L	$\theta = \psi = 0^\circ$	200	230		
Uniformity(5P)		ΔL	$\theta = \psi = 0^\circ$	-	20	25	%
Uniformity(13P)		ΔL	$\theta = \psi = 0^\circ$	-	-	38	%
Response Time		Tr	$\theta = \psi = 0^\circ$	-	6	9	ms
		Tf	$\theta = \psi = 0^\circ$	-	10	16	ms
Image sticking		Tis	2hour	-	-	2	s
Cross talk		CT	$\theta = \phi = 0^{93}$	-	-	1	%
View angle	Horizontal	ψ	CR \geq 10	55/55	60/60	-	°
	Vertical	θ		50/40	55/45	-	°
Color Temperature Coordinate	W	X	$\theta = \psi = 0^\circ$	0.283	0.313	0.343	Color Temperature Coordinate
		Y		0.299	0.329	0.359	
	R	X		0.584	0.614	0.644	
		Y		0.306	0.336	0.366	
	G	X		0.281	0.311	0.341	
		Y		0.534	0.564	0.594	
	B	X		0.123	0.153	0.183	
		Y		0.100	0.130	0.160	
Gamut			$\theta = \psi = 0^\circ$	45%	50%		%
Gamma(VESA)		γ	GL(4~63)	2.0	2.2	2.4	

【Note】

Measure device:BM-5A (TOPCON) under the dark room condition

Measurement Condition:IL= 6.0mA

Inverter: SUMIDA / Mode : IV11145T

***1) Definition of Contrast Ratio :**

CR=ON (White) Luminance/ OFF(Black) Luminance

***2) Definition of Luminance and Luminance uniformity Central luminance:**

Central luminance : Measuring the white luminance of 5th point in the below figure.

5P Luminance (AVG): Measuring white luminance of 5 points (NO.5,10,11,12,13) in the below figure and take the average value.

5P Uniformity: $\Delta L = [(L_{MAX} - L_{MIN})/L_{MIN}] \times 100\%$ 13P Uniformity: $\Delta L = [(L_{MAX} - L_{MIN})/L_{MIN}] \times 100\%$ (Measuring points: no.1~13)

Measuring points are as below.

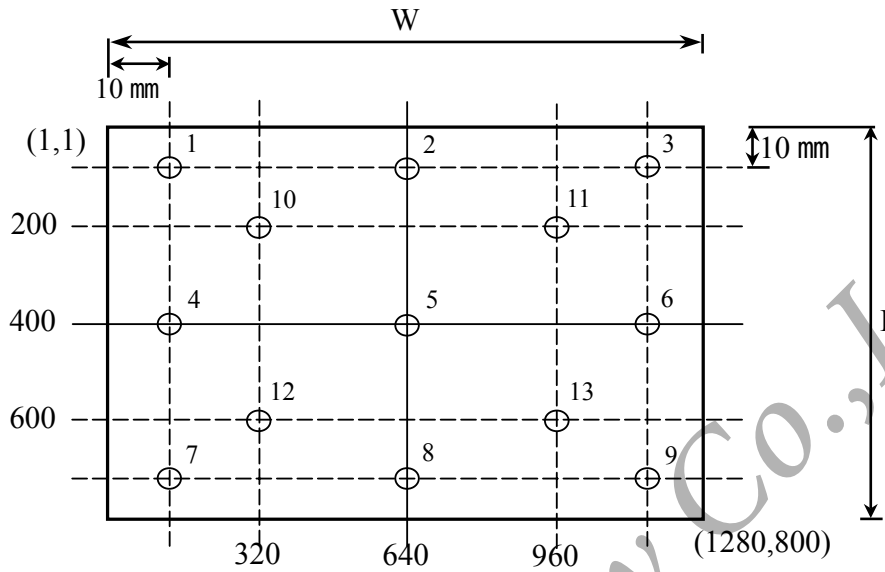

*3) Definition of response time

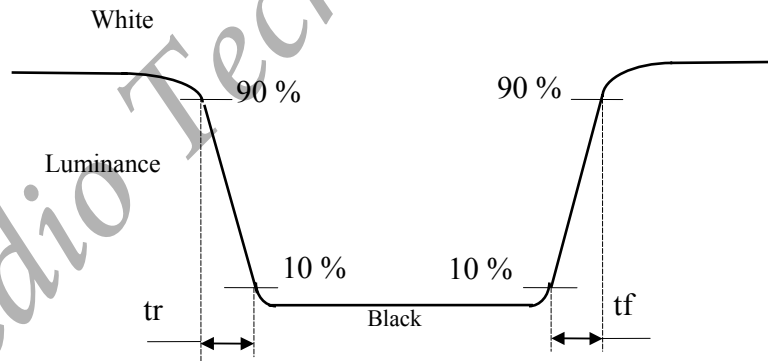

*4) Definition of image sticking

Continuously display the test pattern showing in the below figure for 2hrs at 25°C.

Then switch to gray pattern (the 32nd gray level pattern), and the previous image should not persist more than 2 sec.

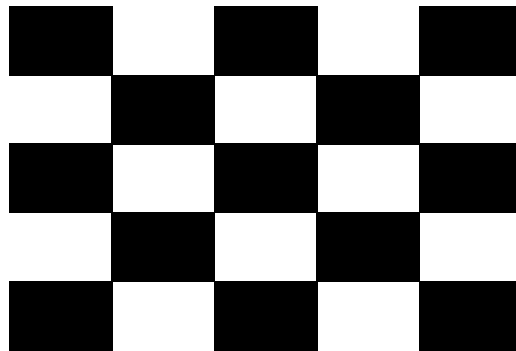

White : 63 Gray
Black : 0 Gray

*5) Crosstalk Ratio measure method

$$CT = |Y_B - Y_A| / Y_A \times 100 (\%)$$

Y_A 、 Y_B measure position and definition

Y_A means luminance at gray level 32nd (exclude gray level 0 pattern)

Y_B means luminance at gray level 32nd (include gray level 0 pattern)

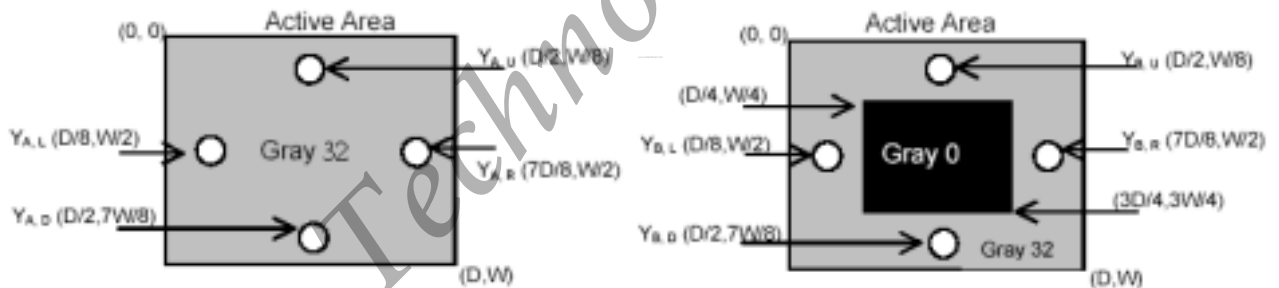

*6) Definition of view angle(θ 、 ψ)

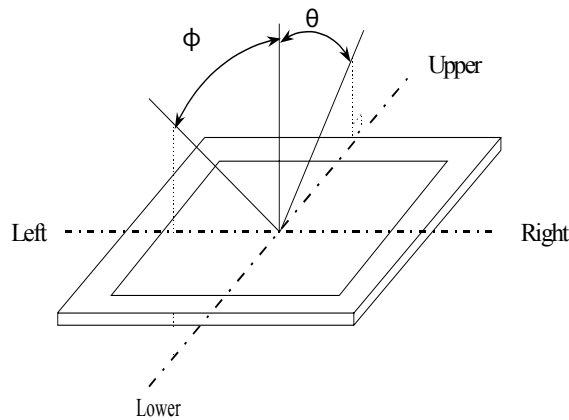

*7) Definition of Gamma

Based on VESA test method, get 17 points (luminance of gray level 0、4、8、12...63)

X axis = $\log(\text{level } X)$ ($X = \text{gray level } 4、8、12...63$)

Y axis = $\log(\text{level } Y - \text{level } Y_0)$ ($Y_x = \text{luminance of gray level } 4、8、12...63$, $Y_0 = \text{luminance of gray level } 0$)

the variation range of Gamma value caused by loop voltage error should be between ± 0.2 .
the below figure shows how to obtain the gamma curve and γ (from gray level 0~63)

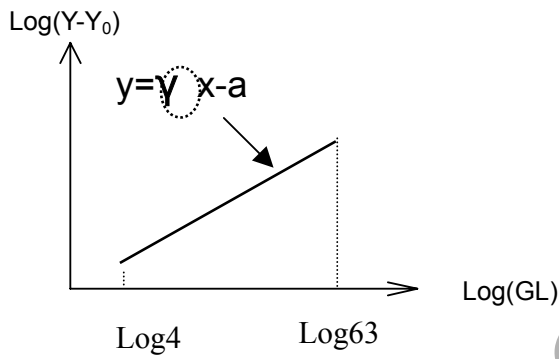

Studio Technology Co., Ltd

9.RELIABILITY TEST CONDITIONS

9.1 Temperature and Humidity

TEST ITEMS	CONDITIONS
High Temperature Operation	50° C ; 240HR
High Temperature Storage	60° C ; 240HR
High Temperature High Humidity Operation	50° C ; 90% RH ; 240HR(No condensation)
High Temperature High Humidity Storage	60° C ; 90% RH ; 48HR(No condensation)
Low Temperature Operation	0° C ; 240HR
Low Temperature Storage	-20° C ; 240HR
Thermal Shock	-20°C to +60°C, 100 cycles Ramp $\geq 20^{\circ}\text{C}/\text{min}$ Duration 30 min at temp.

9.2 Shock & Vibration

TEST ITEMS	CONDITIONS
Shock (Non-Operation)	Shock level: 2450m/s^2 , 250G, Waveform: half sinusoidal wave, 2ms 6 axis ($\pm X, \pm Y, \pm Z$) per cycle
Vibration (Non-Operation)	Vibration level: 14.7m/s^2 , 1.5G, sinusoidal wave (each x,y,z axis: 1hr, total 3 hrs) Frequency range: 5Hz to 500 Hz Sweep speed : 0.5 Octave/min.

9.3 ESD test

Test Item	Test statements
Connector	200 pF , 0Ω , $\pm 250 \text{ V}$ By using contact-mode to discharge each pin one time and then check the module frame.
Module	150pF , 330Ω , , $\pm 8\text{KV}$, $\pm 15\text{KV}$ 1. Under test conditions, by using air-mode to discharge each test point 25 times continuously and then check the module frame. 2. Under test conditions, by using contact-mode to discharge each test point of panel frame 25 times continuously and then check the module frame.

9.4 Judgment standard

The judgment of the above test should be made as follow:

Pass : Normal display image with no obvious non-uniformity and no line defect.

Partial transformation of the module parts should be ignored.

Fail : No display image, obvious non-uniformity, or line defects.

10. HANDLING PRECAUTIONS FOR TFT-LCD MODULE

Please pay attention to the followings in handling- TFT-LCD products.

10.1 ASSEMBLY PRECAUTION

- (1) Please use the mounting hole on the module side in installing and do not beading or wrenching LCD in assembling. And please do not drop, bend or twist LCD module in handling.
- (2) Please design display housing in accordance with the following guidelines.
 - Housing case must be destined carefully so as not to put stresses on LCD all sides and not to wrench module. The stresses may cause non-uniformity even if there is no non-uniformity statically.
 - Keep sufficient clearance between LCD module back surface and housing when the LCD module is mounted. Approximately 1.0 mm of the clearance in the design is recommended taking into account the tolerance of LCD module thickness and mounting structure height on the housing.
 - When some parts, such as, FPC cable and ferrite plate, are installed underneath the LCD module, still sufficient clearance is required, such as 0.5mm. This clearance is, especially, to be reconsidered when the additional parts are implemented for EMI countermeasure.
 - Design the inverter location and connector position carefully so as not to give stress to lamp cable, or not to interface the LCD module by the lamp cable.
 - Keep sufficient clearance between LCD module and the others parts, such as inverter and speaker so as not to interface the LCD module. Approximately 1.0mm of the clearance in the design is recommended.
- (3) Please do not push or scratch LCD panel surface with any-thing hard. And do not soil LCD panel surface by touching with bare hands. (Polarizer film, surface of LCD panel is easy to be flawed.)
- (4) Please do not press any parts on the rear side such as source TCP, gate TCP, control circuit board and FPCs during handling LCD module. If pressing rear part is unavoidable, handle the LCD module with care not to damage them.
- (5) Please wipe out LCD panel surface with absorbent cotton or soft clothe in case of it being soiled.
- (6) Please wipe out drops of adhesives like saliva and water on LCD panel surface immediately. They might damage to cause panel surface variation and color change.
- (7) Please do not take a LCD module to pieces and reconstruct it. Resolving and reconstructing modules may cause them not to work well.
- (8) Please do not touch metal frames with bare hands and soiled gloves. A color change of the metal frames can happen during a long preservation of soiled LCD modules.
- (9) Please pay attention to handling lead wire of backlight so that it is not tugged in connecting with inverter.

10.2 OPERATING PRECAUTIONS

- (1) Please be sure to turn off the power supply before connecting and disconnecting signal input cable.
- (2) Please do not change variable resistance settings in LCD module. They are adjusted to the most suitable value. If they are changed, it might happen LCD does not satisfy the characteristics specification.
- (3) Please consider that LCD backlight takes longer time to become stable of radiation characteristics in low temperature than in room temperature.
- (4) A condensation might happen on the surface and inside of LCD module in case of sudden change of ambient temperature.
- (5) Please pay attention to displaying the same pattern for very long time. Image might stick on LCD. If

then, time going on can make LCD work well.

(6) Please obey the same caution descriptions as ones that need to pay attention to ordinary electronic parts.

10.3 PRECAUTIONS WITH ELECTROSTATICS

- (1) This LCD module use CMOS-IC on circuit board and TFT-LCD panel, and so it is easy to be affected by electrostatics. Please be careful with electrostatics by the way of your body connecting to the ground and so on.
- (2) Please remove protection film very slowly on the surface of LCD module to prevent from electrostatics occurrence.

10.4 STORAGE PRECAUTIONS

- (1) When you store LCDs for a long time, it is recommended to keep the temperature between 0°C ~40°C without the exposure of sunlight and to keep the humidity less than 90%RH.
- (2) Please do not leave the LCDs in the environment of high humidity and high temperature such as 60°C and 90%RH.
- (3) Please do not leave the LCDs in the environment of low temperature(below -20°C.)

10.5 SAFETY PRECAUTIONS

- (1) When you waste LCDs, it is recommended to crush damaged or unnecessary LCDs into pieces and wash them off with solvents such as acetone and ethanol, which should later be burned.
- (2) If any liquid leaks out of a damaged-glass cell and comes in contact with the hands, wash off thoroughly with soap and water.

10.6 OTHERS

- (1) A strong incident light into LCD panel might cause display characteristic changing inferior because of polarizer film, color filter, and other materials becoming inferior. Please do not expose LCD module direct sunlight and strong UV rays.
- (2) Please pay attention to a panel side of LCD module not to contact with other materials in preserving it alone.
- (3) For the packaging box, please pay attention to the followings:
 - Packaging box and inner case for LCD are designed to protect the LCDs from the damage or scratching during transportation. Please do not open except picking LCDs up from the box.
 - Please do not pile them up more than 3 boxes. (They are not designed so.) And please do not turn over.
 - Please handle packaging box with care not to give them sudden shock and vibrations. And also please do not throw them up.
 - Packing box and inner case for LCDs are made of cardboard. So please pay attention not to get them wet. (Such like keeping them in high humidity or wet place can occur getting them wet.)