



Chunghwa Picture Tubes, Ltd.

Technical Specification

To :

Date :

CPT TFT-LCD

CLAA156WA11A

ACCEPTED BY :

APPROVED BY	CHECKED BY	PREPARED BY

Prepared by :

Doc.No:	CLAA156WA11A	Issue Date:	
----------------	--------------	--------------------	--

Modification Record List

NO.	Issue Date	Modification Index
1	2008/08/05	First Edition
2		
3		
4		
5		
6		
7		
8		
9		
10		
11		

Table Of Content

NO.	Table of Content	Page
1	OVERVIEW	4
2	ABSOLUTE MAXIMUM RATINGS	5
3	ELECTRICAL CHARACTERISTICS	6
4	CONNECTOR INTERFACE PIN & FUNCTION	10
5	INTERFACE TIMING CHART	12
6	BLOCK DIAGRAM	14
7	MECHANICAL SPECIFICATION	15
8	OPTICAL CHARACTERISTICS	17
9	RELIABILITY TEST CONDITIONS	21
10	HANDLING PRECAUTIONS FOR TFT-LCD MODULE	23

1. OVERVIEW

CLAA156WA11A is 15.6" color (16 : 9) TFT-LCD (Thin Film Transistor Liquid Crystal Display) module composed of LCD panel, LVDS driver ICs, control circuit and backlight. By applying 6 bit digital data, 1366×RGB (3) ×768, 262K-color images are displayed on the 15.6" diagonal screen. general specifications are summarized in the following table :

ITEM	SPECIFICATION
Display Area (mm)	344.232 (H)x193.536 (V) (15.6-inch diagonal)
Number of Pixels	1366 ×3(H)×768 (V)
Pixel Pitch (mm)	0.252 (H)×0.252(V)
Color Pixel Arrangement	RGB vertical stripe
Display Mode	Normally white
Number of Colors	262,144(6bits)(LVDS)
Gamut	56%(min)/60%(typ)
Optimum Viewing Angle	6 o'clock
Response Time (ms)	8ms (Typ)
Surface Treatment	Glare
Viewing Angle	40°、40°/15°、30°(Min.)
Brightness (cd/m ²)	220 cd/m ² (5point)/6 mA (Typ.) 200 cd/m ² (5point)/6 mA (Min.)
Uniformity	5point : 80% 13point : 65%
Consumption of Power (W)	(6.15)W (Max)
Module Size (mm)	359.8(W)×210(H)×5.5(D) (Max)
Module Weight (g)	450 (max)

The LCD Products listed on this document are not suitable for use of aerospace equipment, submarine cable, and nuclear reactor control system and life support systems. If customers intend to use these LCD products for applications listed above or those not included in the "Standard" list as follows, please contact our sales in advance.

Standard : Computer, Office equipment, Communication equipment, Test and Measurement equipment, Machine tool, Industrial robot, Audio and Visual equipment, Other consumer products.

2. ABSOLUTE MAXIMUM RATINGS

The following are maximum value, which if exceeded, may cause faulty operation or damage to the unit.

ITEM	SYMBOL	MIN.	MAX.	UNIT	REMARK
Power Supply Voltage for LCD	VCC	0	4.0	V	
LED Driver Input Voltage	VBL+	(7.5)	(2.1)	V	
LED Driver Input Current	IBL+	TBD	TBD	mA	
PWM Frequency	PWM_BL	TBD	TBD	KHz	*7)
LED Forward Voltage	V _F	3.0	3.5	V	
LED Forward Current	I _F	-	30	mA	*1).2)
Operation Temperature	Top	(0)	(50)	°C	*3). 4). 5). 6)
Storage Temperature	Tstg	(-25)	(65)	°C	*3). 4). 5)

【Note】

- *1) Product life-time relate to LED current, please operate production follow statement at page 9 “(b)back light” .
- *2) When LED current over the definition of absolute max, product life-time will decay rapidly or operate unusual.
- *3) The relative temperature and humidity range are as below sketch, 90%RH Max. (Ta ≤ 40°C)
- *4) The maximum wet bulb temperature ≤ 39°C (Ta > 40°C) and without dewing.
- *5) If product in environment which over the definition of the relative temperature and humidity out of range too long, it will affect visual of LCD.
- *6) If you operate LCD in normal temperature range, the center surface of panel should be under 50°C.
- *7) The External PWM frequency’s typical value is 10 KHz with an amplitude of 3.3V .

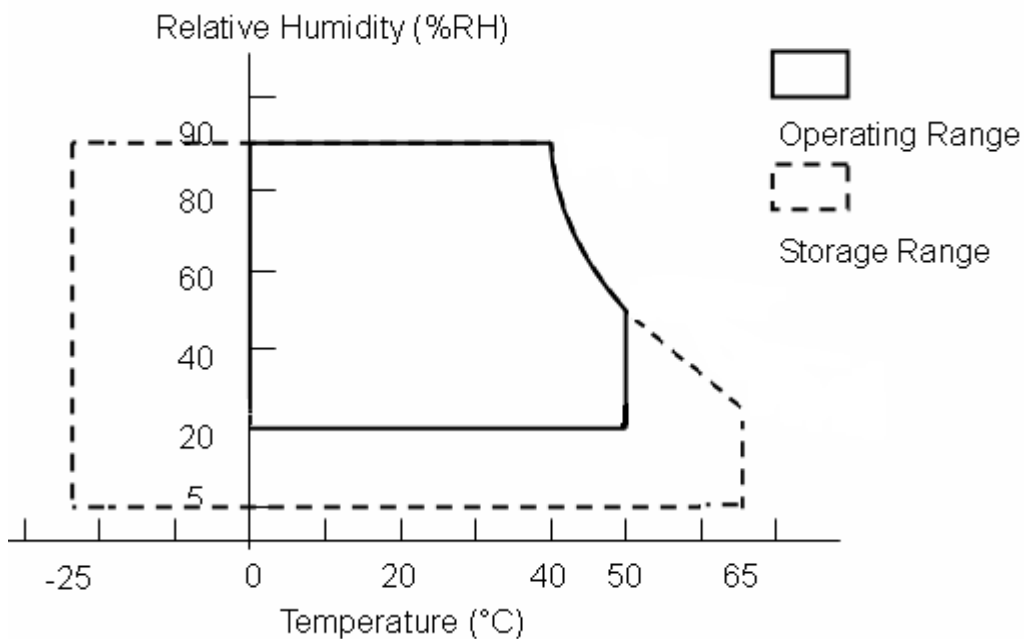

3. ELECTRICAL CHARACTERISTICS

(A) TFT LCD

TEM	SYMBOL	MIN	TYP	MAX	UNIT	REMARK	
LCD POWER VOLTAGE	VCC	3.0	3.3	3.6	V	【Note 1】	
LCD POWER CURRENT	ICC	-	(400)	(500)	mA	【Note 2】	
Rush CRRENT	Irush	-	-	2	A	【Note 4】	
LOGIC INPUT VOLTAGE (LVDS: IN+,IN-)	INPUT VOLTAGE	VIN	0	-	VCC	V	【Note 3】
	COMMON VOLTAGE	VCM	1.125	1.25	1.375	V	【Note 3】
	DIFFERENTIAL INPUT VOLTAGE	VID	250	350	450	mV	【Note 3】
	THRESHOLD VOLTAGE (HIGH)	VTH	-	-	100	mV	【Note 3】 When VCM = +1.2V
	THRESHOLD VOLTAGE (LOW)	VTL	-100	-	-	mV	
DIFFERENTIAL INPUT VOLTAGE TOLERANCE	Δ VID	-	-	35	mV		
COMMON VOLTAGE TOLERANCE	Δ VCM	-	-	35	mV		

【Note 1】 Power Sequence :

- $0.5 \text{ ms} \leq t1 \leq 10 \text{ ms}$
- $0.01 \text{ ms} < t2 \leq 50 \text{ ms}$
- $0.01 \text{ ms} < t3 \leq 50 \text{ ms}$
- $1 \text{ sec} \leq t4$
- $200 \text{ ms} \leq t5$
- $200 \text{ ms} \leq t6$

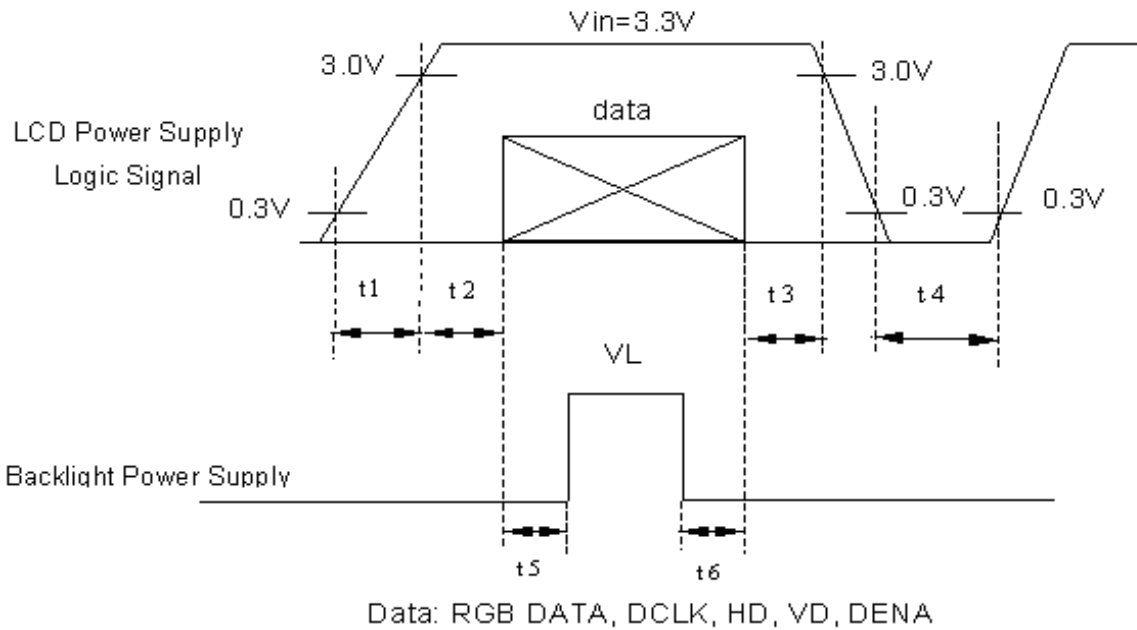

VCC-dip state

- (1) when $3.0 > VCC \geq 2.7V$, $t_d \leq 10 \text{ ms}$
- (2) when $VCC < 2.7V$, VCC-dip condition should as the VCC-turn-off condition.

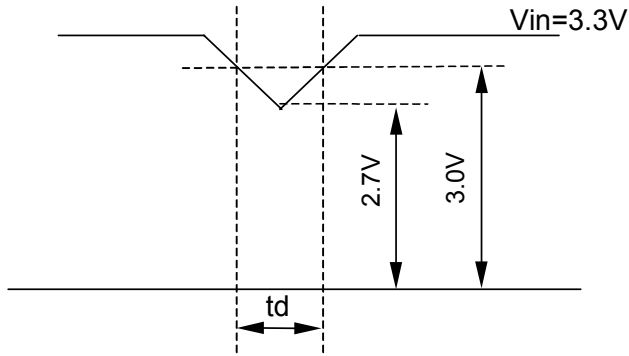

【Note 2】 Typical value is 0~63 gray level.(Horizontal line Pattern)

768 line mode , $VCC= +3.3V$

Circuit condition (Typ.) :

$VCC=3.3 V$, $f_v=60 Hz$ $f_H=48.36 kHz$, $f_{CLK}=75.44 MHz$

64-Gray



Circuit condition (Max.) :

$VCC=3.3 V$, $f_v=60 Hz$ $f_H=48.36 kHz$, $f_{CLK}=75.44 MHz$

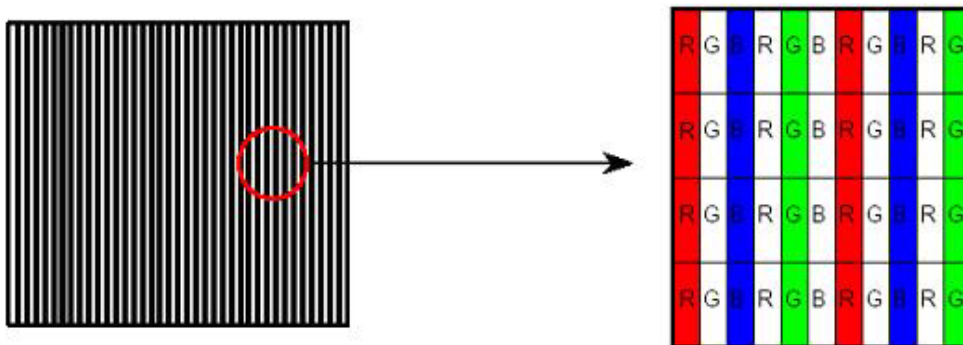

【Note 3】 LVDS Signal Definite :

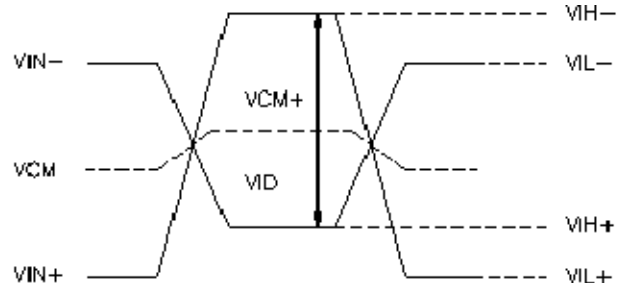
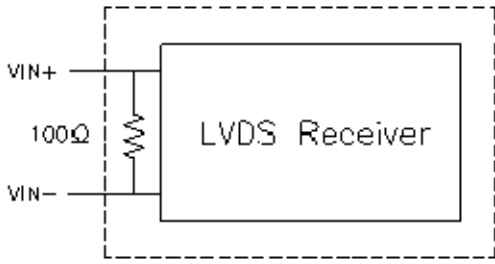

VIN+ : Positive differential DATA & CLK Input

VIN- : Negative differential DATA & CLK Input

$$VID = VIN+ - VIN-$$

$$\Delta VCM = | VCM+ - VCM- |$$

$$\Delta VID = | VID+ - VID- |$$

$$VID+ = | VIH+ - VIH- |$$

$$VID- = | VIL+ - VIL- |$$

$$VCM = (VIN+ + VIN-)/2$$

$$VCM+ = (VIH+ + VIH-)/2$$

$$VCM- = (VIL+ + VIL-)/2$$

【Note 4】 Irush measure condition

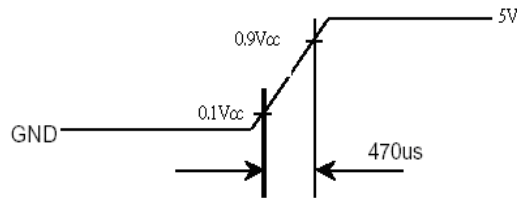
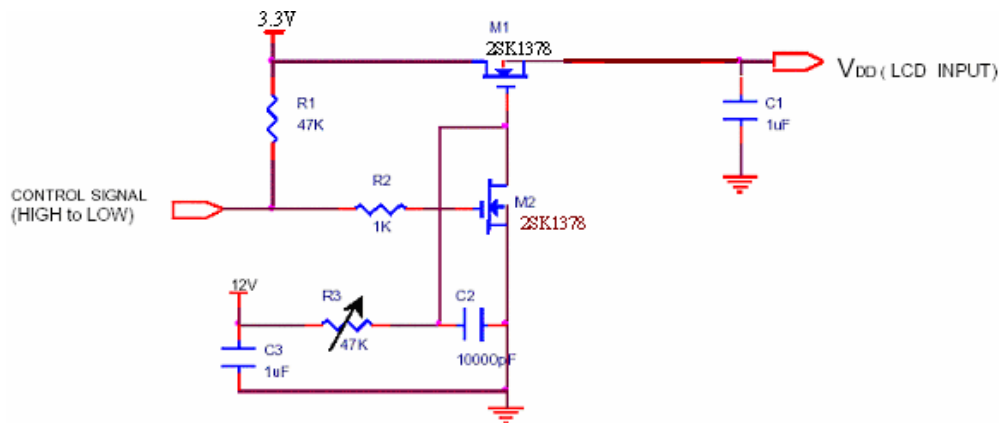

(B) BACK LIGHT

(a.) ELECTRICAL CHARACTERISTICS

Ta=25°C

ITEM	SYMBOL	MIN	TYP	MAX	UNIT	REMARK
Forward Voltage	VF	(3.0)	(3.2)	(3.5)	V	I _F =20mA
Forward Current	IF	(18)	(20)	(22)	mA	*1)
Power consumption	W	TBD	(64)	TBD	mW	I _F =20mA

(b) LED LIFE – TIME

ITEM	Condition	min	typ	max	UNIT	REMARK
LIFE TIME	I _F =20mA · Ta=25°C	15000			hrs	*2)

*1)Measure method : Galvanometer connect to low voltage

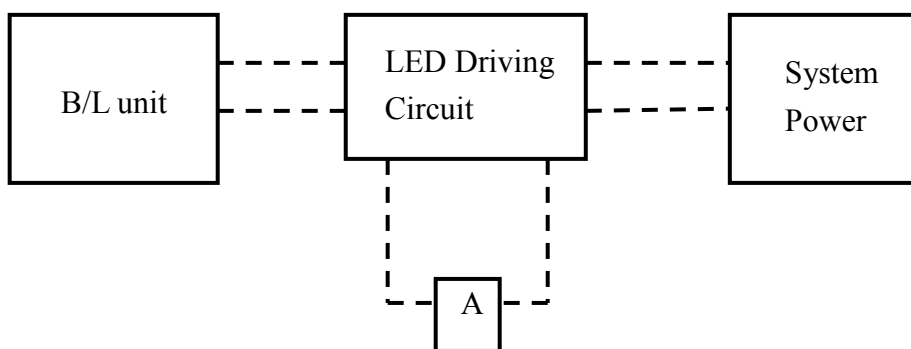

*2)Life time means that estimated time to 50% degradation of initial luminous intensity.

4. Connector Interface PIN & Function

CN(Interface signal)

Outlet connector: 20455-040E-02 (I-PEX)

Pin No.	SYMBOL	FUNCTION
1	DIAG_LOOP	Diag pin for Dell testing. Pin 1 & 34 must be connected together on the inverter board
2	VDD	Power Supply, 3.3 V (typical)
3	VDD	Power Supply, 3.3 V (typical)
4	V EEDID	DDC 3.3V power
5	TEST	Panel Self Test
6	Ck EEDID	DDC Clock
7	DATA EEDID	DDC Data
8	Odd_Rin0-	- LVDS differential data input (R0-R5, G0) (odd pixels)
9	Odd_Rin0+	+ LVDS differential data input (R0-R5, G0) (odd pixels)
10	VSS	Ground – Shield
11	Odd_Rin1-	- LVDS differential data input (G1-G5, B0-B1) (odd pixels)
12	Odd_Rin1+	+ LVDS differential data input (G1-G5, B0-B1) (odd pixels)
13	VSS	Ground – Shield
14	Odd_Rin2-	- LVDS differential data input (B2-B5, HS, VS, DE) (odd pixels)
15	Odd_Rin2+	+ LVDS differential data input (B2-B5, HS, VS, DE) (odd pixels)
16	VSS	Ground – Shield
17	Odd_CikIN-	- LVDS differential clock input (odd pixels)
18	Odd_CikIN+	+ LVDS differential clock input (odd pixels)
19	NC	No connection
20	NC	No connection
21	NC	No connection
22	NC	No connection
23	NC	No connection
24	NC	No connection
25	NC	No connection
26	NC	No connection
27	NC	No connection
28	NC	No connection
29	NC	No connection
30	NC	No connection
31	VSSLED	Ground – LED
32	VSSLED	Ground – LED
33	VSSLED	Ground – LED
34	DIAG_LOOP	Diag pin for Dell testing. Pin 1 & 34 must be connected together on the inverter board
35	PWM	System PWM Signal Input (+3.3V Swing)
36	LED_EN	LED enable pin (+3.3V Input)
37	NC	NC
38	VDDLED	7.5V – 21V LED power
39	VDDLED	7.5V – 21V LED power
40	VDDLED	7.5V – 21V LED power

【Note】

BIST (Build in self-test pattern)

BIST pin = low(GND) : Normal

BIST pin = high(VCC) : Self-test mode

(1). Self-test Display Pattern change when pin 5 is high and no LVDS input signals detected, as followed patterns runs continuously. (Black, White, Red, Green and Blue).

(2). Pattern sequence

Pattern1 → Pattern2 → Pattern3 → Pattern4 → Pattern5 → Pattern1 →

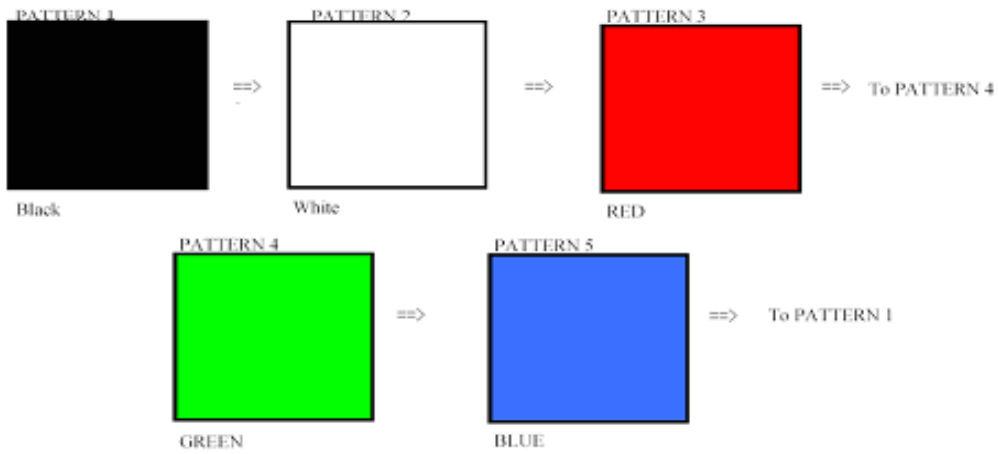

Recommendable Display Pattern Sequence

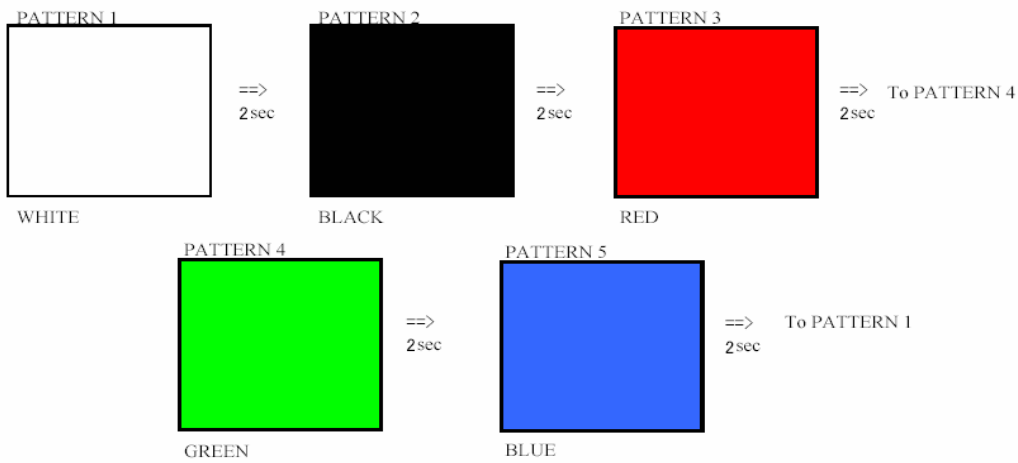

Alternative Display Pattern Sequence

5. INTERFACE TIMING CHART

(1)(a). LVDS input time sequence

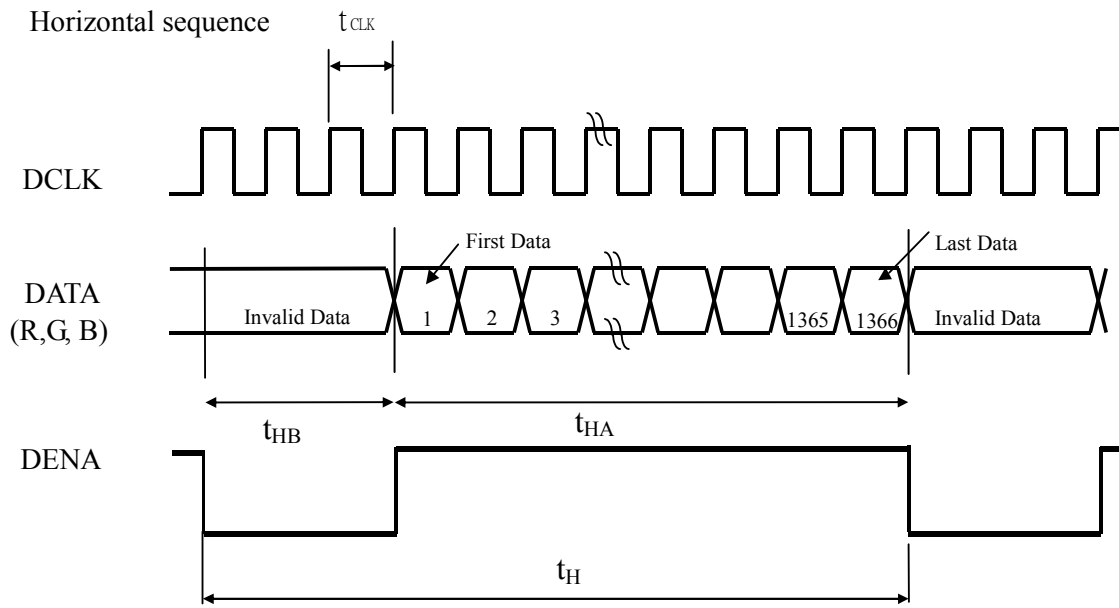

(b) LCD input time sequence

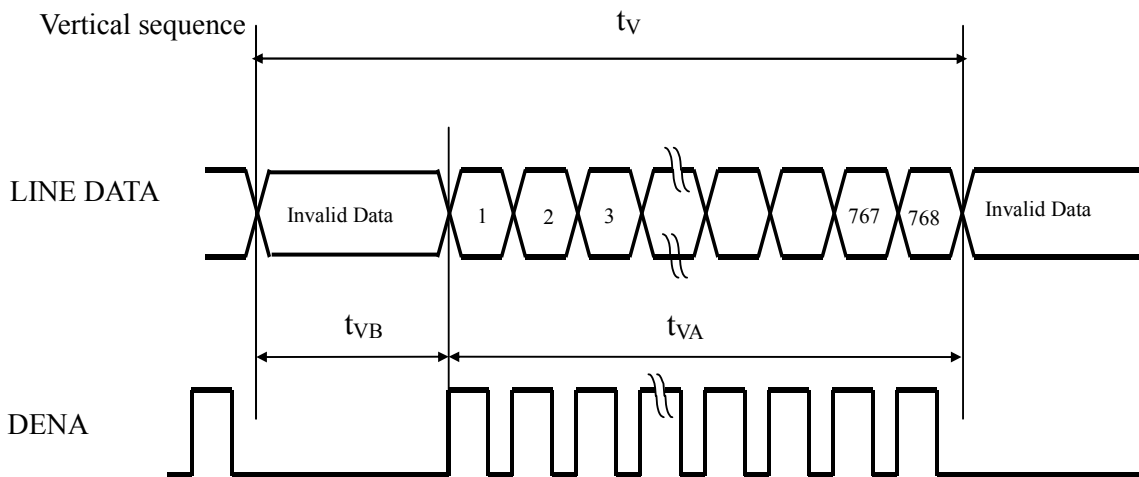

(2) Timing Chart

ITEM			SYMBOL	MIN	TYP	MAX	UNIT	
LCD Timing	Frame Rate		-	60	60	60	Hz	
	DCLK		Frequency	f_{CLK}	65.83	75.44	88.74	MHz
			Period	t_{CLK}	11.26	13.25	15.19	ns
	DENA	Horizontal	Horizontal total time	t_H	1414	1560	1700	t_{CLK}
			Horizontal Active time	t_{HA}	1366	1366	1366	t_{CLK}
			Horizontal Blank time	t_{HB}	48	194	334	t_{CLK}
		Vertical	Vertical total time	t_V	776	806	870	t_H
			Vertical Active time	t_{VA}	768	768	768	t_H
			Vertical Blank time	t_{VB}	8	38	114	t_H

【Note】

- *1) Data is latched during DCLK falling period.
- *2) HD、VD is negative.
- *3) DENA (DATA ENABLE) usually is positive.
- *4) During the whole blank period, DCLK should keep input.
During the vertical blank period, HD should keep input.

(3) DATA mapping

Color	Input Data	R DATA						G DATA						B DATA					
		R5	R4	R3	R2	R1	R0	G5	G4	G3	G2	G1	G0	B5	B4	B3	B2	B1	B0
		MS B					LS B	MS B					LS B	MS B					LS B
Basic Color	Black	0	0	0	0	0	0	0	0	0	0	0	0	0	0	0	0	0	0
	Red(63)	1	1	1	1	1	1	0	0	0	0	0	0	0	0	0	0	0	0
	Green(63)	0	0	0	0	0	0	1	1	1	1	1	1	0	0	0	0	0	0
	Blue(63)	0	0	0	0	0	0	0	0	0	0	0	0	1	1	1	1	1	1
	Cyan	0	0	0	0	0	0	1	1	1	1	1	1	1	1	1	1	1	1
	Magenta	1	1	1	1	1	1	0	0	0	0	0	0	1	1	1	1	1	1
	Yellow	1	1	1	1	1	1	1	1	1	1	1	1	0	0	0	0	0	0
	White	1	1	1	1	1	1	1	1	1	1	1	1	1	1	1	1	1	1
RED	RED(0)	0	0	0	0	0	0	0	0	0	0	0	0	0	0	0	0	0	0
	RED(1)	0	0	0	0	0	1	0	0	0	0	0	0	0	0	0	0	0	0
	RED(2)	0	0	0	0	1	0	0	0	0	0	0	0	0	0	0	0	0	0
	RED(62)	1	1	1	1	1	0	0	0	0	0	0	0	0	0	0	0	0	0
	RED(63)	1	1	1	1	1	1	0	0	0	0	0	0	0	0	0	0	0	0
	Green	Green(0)	0	0	0	0	0	0	0	0	0	0	0	0	0	0	0	0	0
Green(1)		0	0	0	0	0	0	0	0	0	0	0	1	0	0	0	0	0	0
Green(2)		0	0	0	0	0	0	0	0	0	0	1	0	0	0	0	0	0	0
Green(62)		0	0	0	0	0	0	1	1	1	1	1	0	0	0	0	0	0	0
Green(63)		0	0	0	0	0	0	1	1	1	1	1	1	0	0	0	0	0	0
Blue	Blue(0)	0	0	0	0	0	0	0	0	0	0	0	0	0	0	0	0	0	0
	Blue(1)	0	0	0	0	0	0	0	0	0	0	0	0	0	0	0	0	0	1
	Blue(2)	0	0	0	0	0	0	0	0	0	0	0	0	0	0	0	0	1	0
	Blue(62)	0	0	0	0	0	0	0	0	0	0	0	0	1	1	1	1	1	0
	Blue(63)	0	0	0	0	0	0	0	0	0	0	0	0	1	1	1	1	1	1

【Note】

- 1) Gray level:
Color(n) : n is level order; higher n means brighter level.
- 2) DATA:
1: high , 0: low

6. BLOCK DIAGRAM

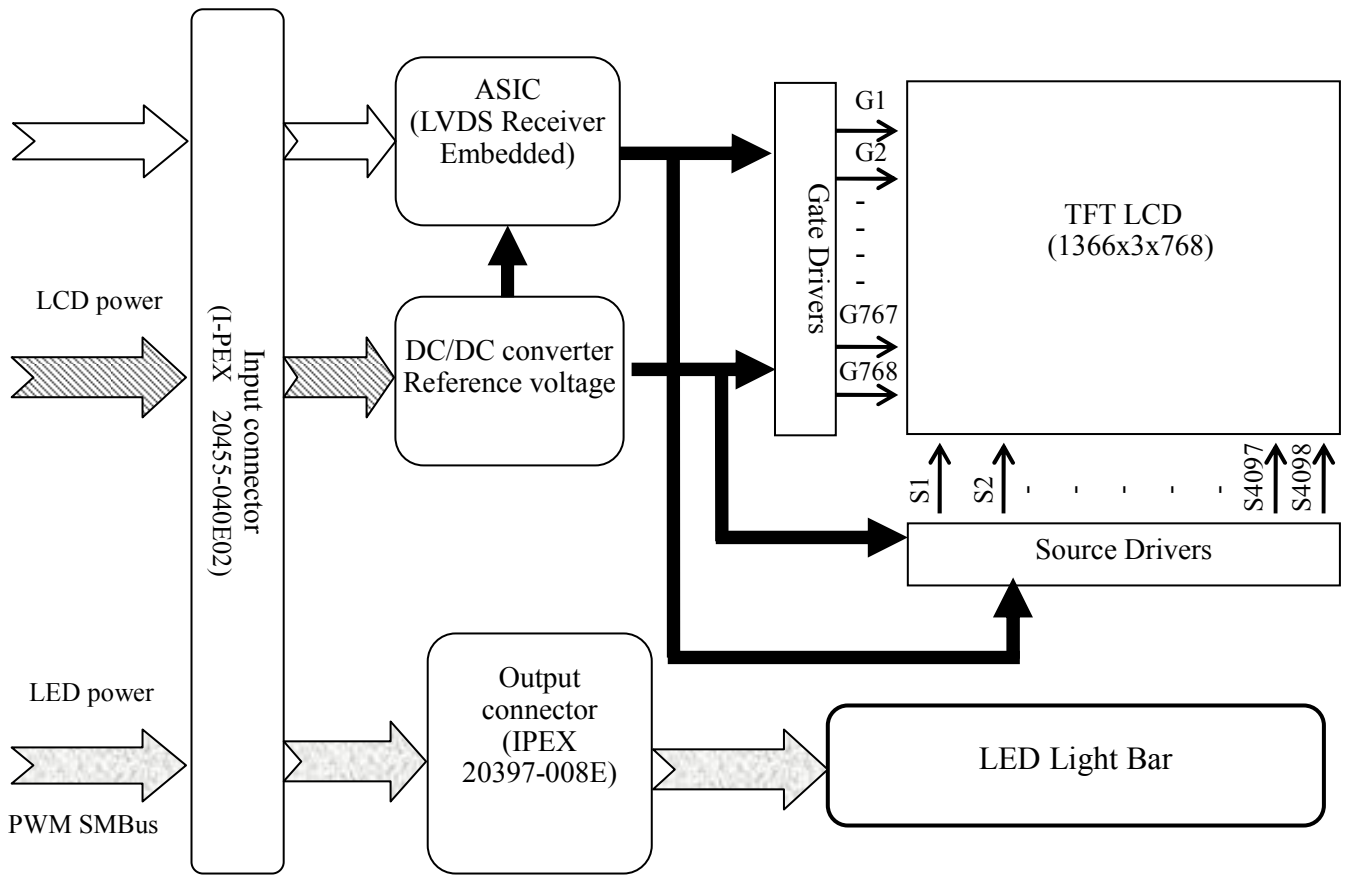

7. MECHANICAL SPECIFICATION

(1) Front side

The tolerance, not show in the figure, is $\pm 0.5\text{mm}$.

[Unit : mm]

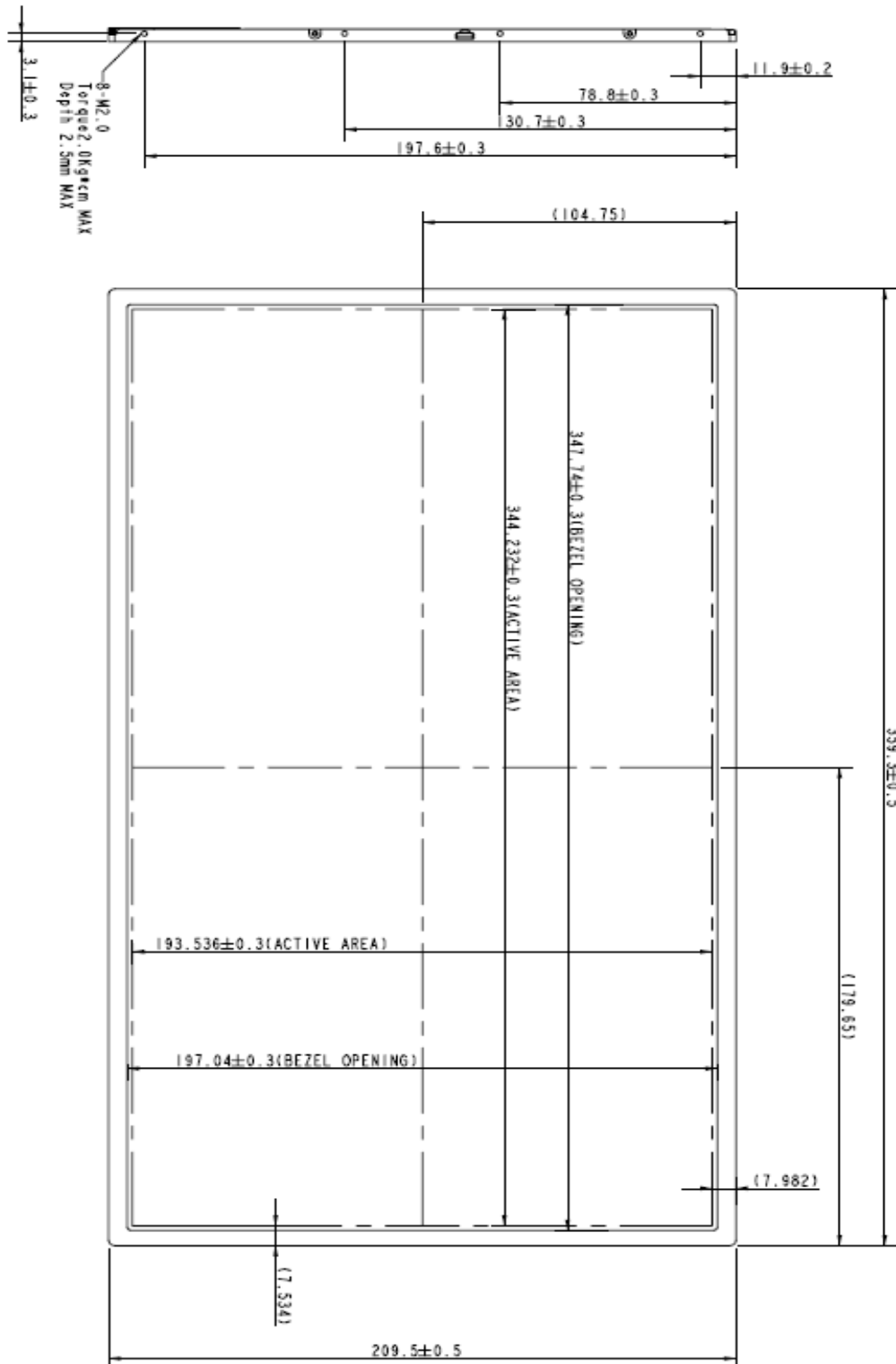

2) Rear side

The tolerance, not show in the figure, is $\pm 0.5\text{mm}$.

[Unit : mm]

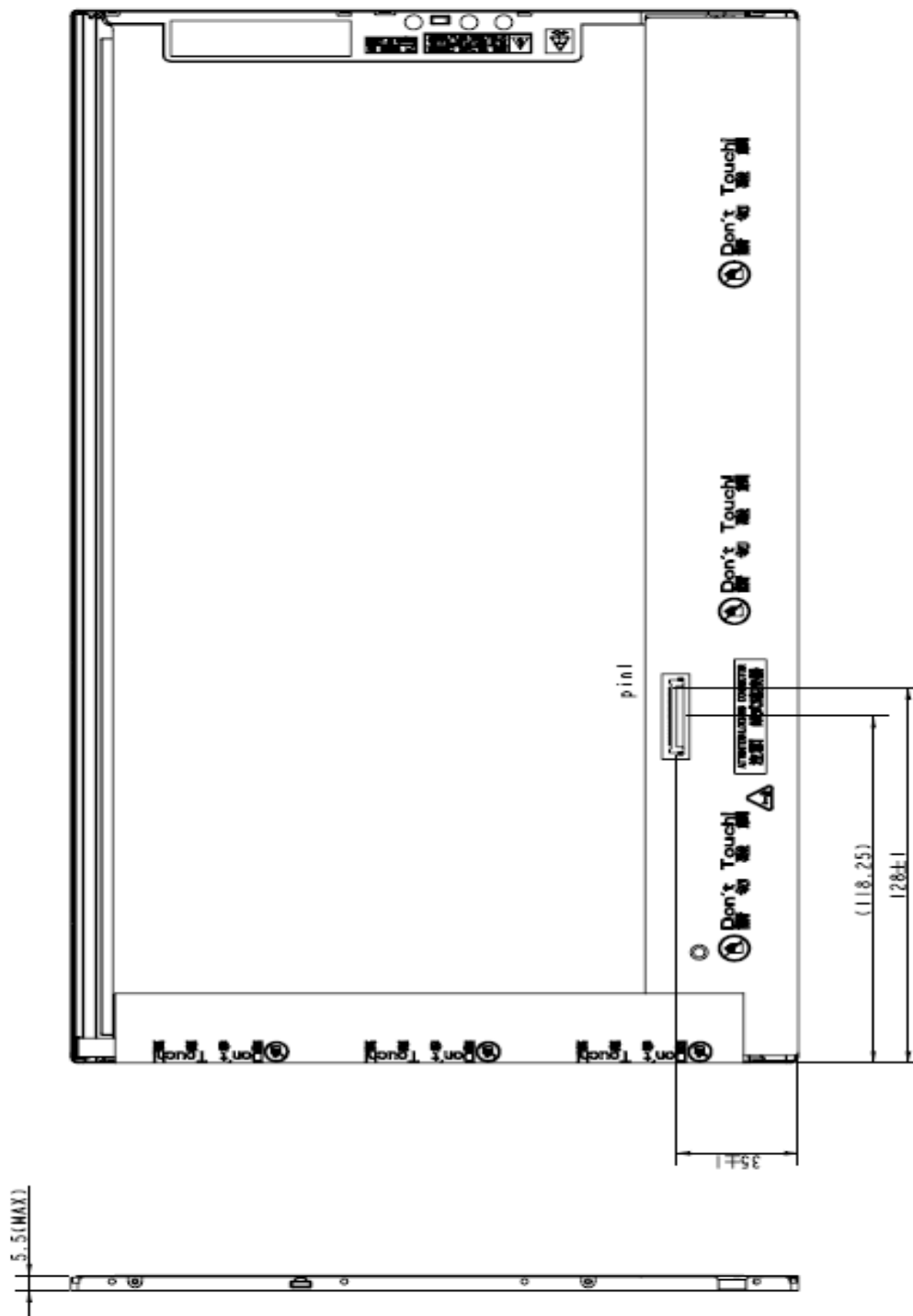

8. OPTICAL CHARACTERISTICS

Ta=25°C , VDD=3.3V

ITEM	SYMBOL	CONDITION	MIN.	TYP.	MAX.	UNIT	REMARK	
Contrast Ratio	CR	$\theta = \psi = 0^\circ$	(400)	600		--	*1) 2)	
Luminance (5P)	L	$\theta = \psi = 0^\circ$	200	220		cd/m ²	*1) 3)	
Uniformity(5P)	ΔL	$\theta = \psi = 0^\circ$	80			%	*1) 3)	
Uniformity(13P)	ΔL	$\theta = \psi = 0^\circ$	65			%	*1) 3)	
Response Time	Tr	$\theta = \psi = 0^\circ$		3	6	ms	*5)	
	Tf	$\theta = \psi = 0^\circ$		5	10	ms	*5)	
Cross talk	CT	$\theta = \phi = 0^{\circ*3}$			1	%	*6)	
View angle	Horizontal	Ψ	$CR \geq 10$	40/-40	45/-45		°	*4)
	Vertical	θ		15/-30	20/-35		°	*4)
Color Temperature Coordinate	W	X	$\theta = \psi = 0^\circ$	0.283	0.313	0.343	*3)	
		Y		0.299	0.329	0.359		
	R	X		(0.590)	(0.620)	(0.650)		
		Y		(0.310)	(0.340)	(0.370)		
	G	X		(0.300)	(0.330)	(0.360)		
		Y		(0.540)	(0.570)	(0.600)		
	B	X		(0.120)	(0.150)	(0.180)		
		Y		(0.030)	(0.060)	(0.090)		
Gamut		$\theta = \psi = 0^\circ$	56%	60%			*7)	
Gamma	γ	GL	2.0	2.2	2.4			

Color coordinate and color gamut are measured by SRUL1R, response time is measured by TRD-100, and all the other items are measured by BM-5A (TOPCON). All these items are measured under the dark room condition (no ambient light).

Measurement Condition: IL=20mA(each LED)

Definition of these measurement items is as follows:

*1) Setup of Measurement Equipment

The LCD module should be turn-on to a stable luminance level to be reached. The measurement should be executed after lighting Backlight for 20 minutes and in a dark room.

*2) Definition of Contrast Ratio

CR=ON (White) Luminance/OFF (Black) Luminance

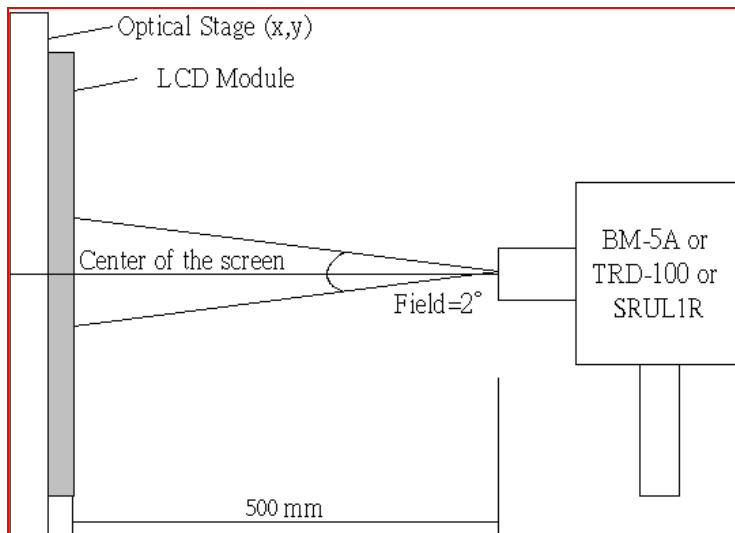

***3) Definition of Luminance and Luminance uniformity**

Central luminance: The white luminance is measured at the center position “5” on the screen, see Fig.1 below.

5P Luminance (AVG): The white luminance is measured at measuring points 5 · 10 · 11 · 12 · 13, see Fig.1 below.

5P Uniformity: $\Delta L = (L_{min} / L_{max}) \times 100\%$

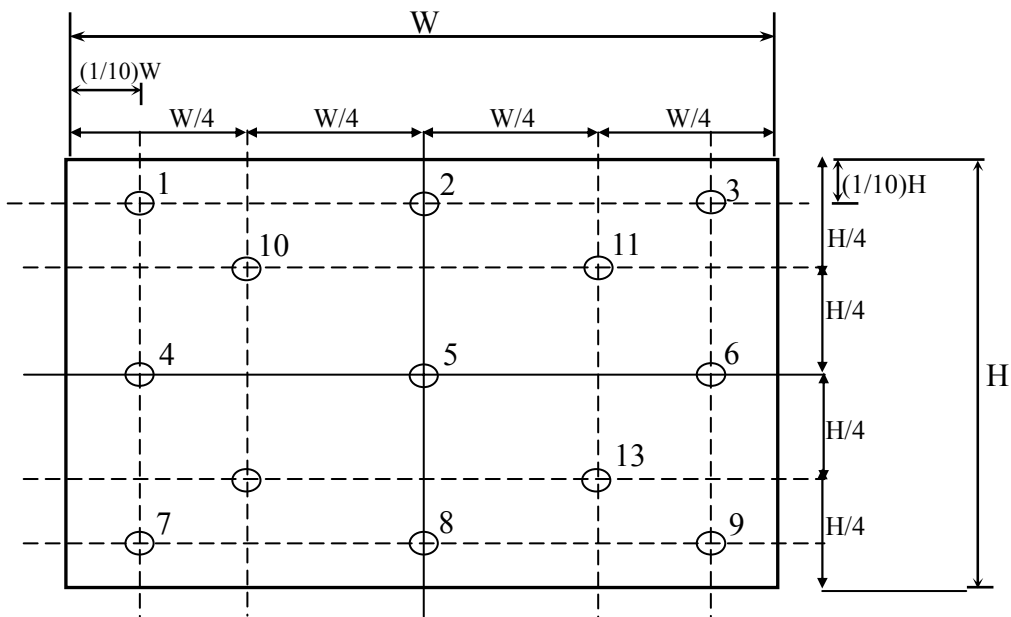
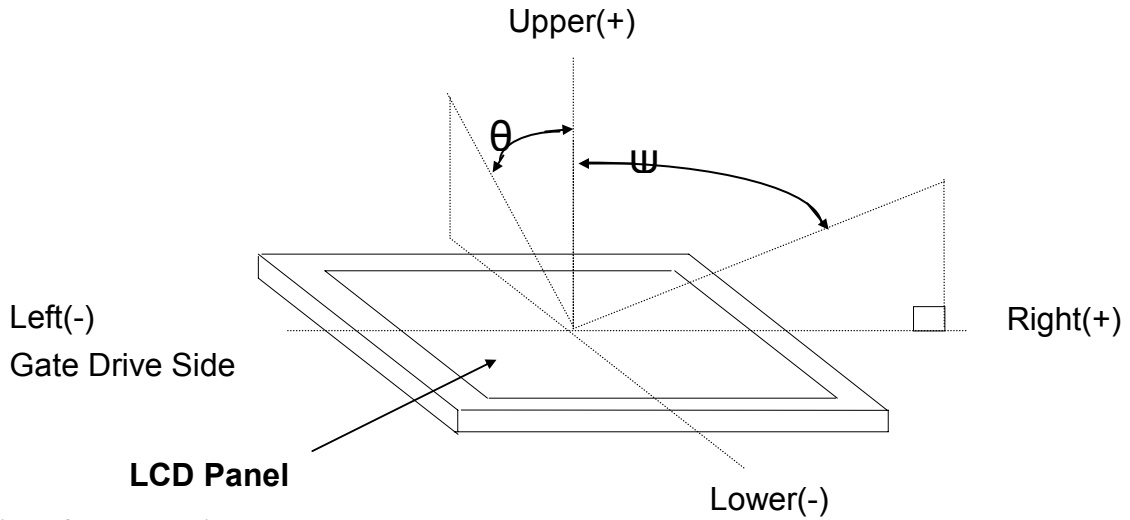
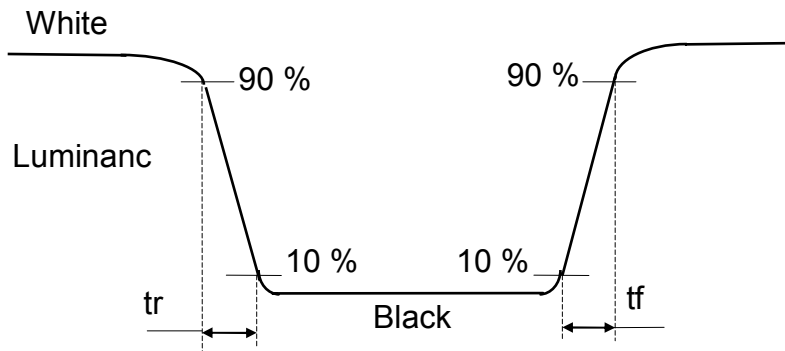

Fig.1 Measure point (Active area)

***4) Definition of view angle(θ , ψ)**



***5) Definition of response time**



***6) Definition of image sticking :**

Continuously display the test pattern shown in the figure below for 16 hrs. At 25°C.

To change the picture to gray pattern (gray 32 pattern), and the previous image shall not persist during 20 min.

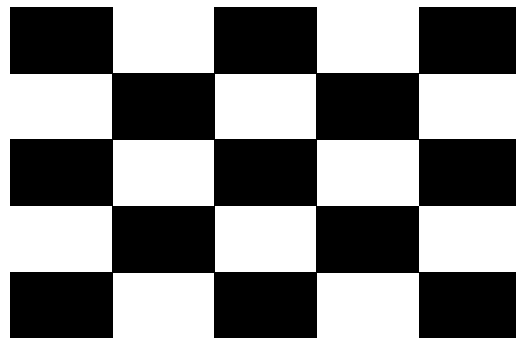

White : 63 Gray

Black : 0 Gray

***7) Crosstalk Modulation Ratio:**

$$CT = | Y_B - Y_A | / Y_A \times 100\%$$

Y_A 、 Y_B measure position and definition

Y_A means luminance at gray level 32(exclude gray level 0 pattern)

Y_B means luminance at gray level 32(include gray level 0 pattern)

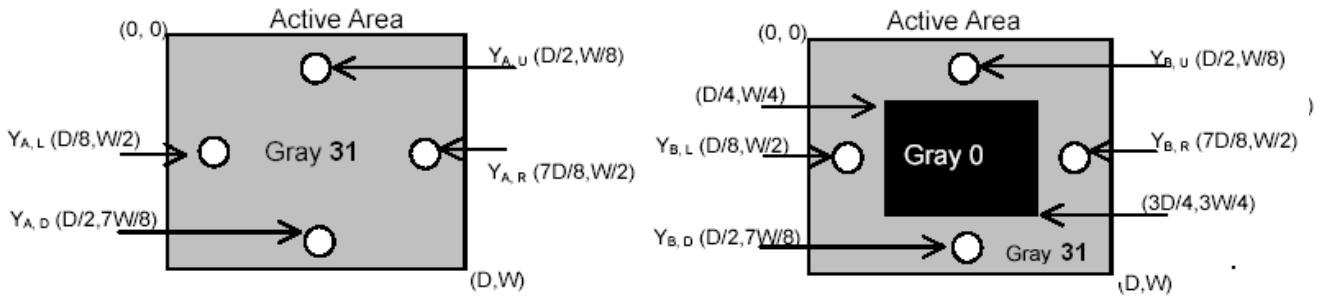

***8) Definition Gamma (VESA)**

Based on Customer Sample, take the average value as a standard center value and the variation range of gamma value caused by loop voltage error should be between +/- 0.2. the bellow figure shows how to obtain the gamma curve and γ (from gray level: 0、4、8-----60、63).

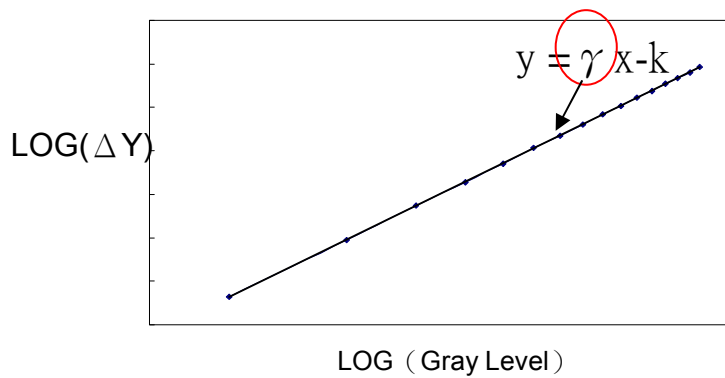

9.RELIABILITY TEST CONDITIONS

9.1 Temperature and Humidity

TEST ITEMS	CONDITIONS
High Temperature Operation	50° C ; 240Hrs
High Temperature Storage	60° C ; 240Hrs
High Temperature High Humidity Operation	50° C ; 90% RH ; 240Hrs
High Temperature High Humidity Storage	60° C ; 90% RH ; 48 Hrs
Low Temperature Operation	0° C ; 240 Hrs
Low Temperature Storage	-20° C ; 240 Hrs
Thermal Shock	-20° C (0.5 hr)~60° C (0.5 hr) , Ramp<20° C , 100 CYCLE

9.2 Shock & Vibration

TEST ITEMS	CONDITIONS
Shock (Non-Operation)	Shock level : 1960m/s ² (200G), Waveform : half sinusoidal wave, 2ms, 6 axis (± X,± Y,± Z) per cycle
Vibration (Non-Operation)	Vibration level : 9.8m/s ² (1.0G), sinusoidal wave (each x, y, z axis : 1hr, total 3hrs) Frequency range : 5~500 Hz Sweep speed : 0.5 Octave/min.

9.3 ESD

	Surface discharge(Panel display area 、 Frame 、 PWB 、 Panel back side)		Electric capacity of Connector
	Contact	Air	Contact
Capacity	150 pF	150 pF	200 pF
Resistance	330 Ω	330 Ω	0 Ω
Voltage	±8kV	±8kV/±15kV	±250 V
Interval	1 sec	1 sec	1 sec
Times(single point)	25	25	1

Acceptance Criteria	Air Discharge	
	+/-8 kV	+/-15 kV
A	Permitted	Permitted
B	Permitted	Permitted
C	Not Permitted	Permitted
D	Not Permitted	Not Permitted

Acceptance Definitions	
A	Normal operation. No degradation. No failures.
B	Some performance degradation allowed. No data lost. Self-recoverable.
C	Temporary performance degradation. Recovery by operator is acceptable.
D	Degradation or loss of function,which is not recoverable due to damage of equipment (components)

9.4 MTBF without B/L: 200,000 Hrs (min) lifetimes.

9.5 Judgment standard

The judgment of the above test should be made as follow:

Pass : Normal display image with no obvious non-uniformity and no line defect.

Partial transformation of the module parts should be ignored.

Fail : No display image, obvious non-uniformity, or line defects.

10. HANDLING PRECAUTIONS FOR TFT-LCD MODULE

Please pay attention to the followings in handling- TFT-LCD products;

10.1 ASSEMBLY PRECAUTION

- (1) Please use the mounting hole on the module side in installing and do not beading or wrenching LCD in assembling. And please do not drop, bend or twist LCD module in handling.
- (2) Please design display housing in accordance with the following guidelines.
 - Housing case must be destined carefully so as not to put stresses on LCD all sides and not to wrench module. The stresses may cause non-uniformity even if there is no non-uniformity statically.
 - Keep sufficient clearance between LCD module back surface and housing when the LCD module is mounted. Approximately 1.0 mm of the clearance in the design is recommended taking into account the tolerance of LCD module thickness and mounting structure height on the housing.
 - When some parts, such as, FPC cable and ferrite plate, are installed underneath the LCD module, still sufficient clearance is required, such as 0.5mm. This clearance is, especially, to be reconsidered when the additional parts are implemented for EMI countermeasure.
 - Design the inverter location and connector position carefully so as not to give stress to lamp cable, or not to interface the LCD module by the lamp cable.
 - Keep sufficient clearance between LCD module and the others parts, such as inverter and speaker so as not to interface the LCD module. Approximately 1.0mm of the clearance in the design is recommended.
- (3) Please do not push or scratch LCD panel surface with any-thing hard. And do not soil LCD panel surface by touching with bare hands. (Polarizer film, surface of LCD panel is easy to be flawed.)
- (4) Please do not press any parts on the rear side such as source TCP, gate TCP, control circuit board and FPCs during handling LCD module. If pressing rear part is unavoidable, handle the LCD module with care not to damage them.
- (5) Please wipe out LCD panel surface with absorbent cotton or soft clothe in case of it being soiled.
- (6) Please wipe out drops of adhesives like saliva and water on LCD panel surface immediately. They might damage to cause panel surface variation and color change.
- (7) Please do not take a LCD module to pieces and reconstruct it. Resolving and reconstructing modules may cause them not to work well.
- (8) Please do not touch metal frames with bare hands and soiled gloves. A color change of the metal frames can happen during a long preservation of soiled LCD modules.
- (9) Please pay attention to handling lead wire of backlight so that it is not tugged in connecting with inverter.

10.2 OPERATING PRECAUTIONS

- (1) Please be sure to turn off the power supply before connecting and disconnecting signal input

cable.

- (2) Please do not change variable resistance settings in LCD module. They are adjusted to the most suitable value. If they are changed, it might happen LCD does not satisfy the characteristics specification.
- (3) Please consider that LCD backlight takes longer time to become stable of radiation characteristics in low temperature than in room temperature.
- (4) A condensation might happen on the surface and inside of LCD module in case of sudden change of ambient temperature.
- (5) Please pay attention to displaying the same pattern for very long time. Image might stick on LCD. If then, time going on can make LCD work well.
- (6) Please obey the same caution descriptions as ones that need to pay attention to ordinary electronic parts.

10.3 PRECAUTIONS WITH ELECTROSTATICS

- (1) This LCD module use CMOS-IC on circuit board and TFT-LCD panel, and so it is easy to be affected by electrostatics. Please be careful with electrostatics by the way of your body connecting to the ground and so on.
- (2) Please remove protection film very slowly on the surface of LCD module to prevent from electrostatics occurrence.

10.4 STORAGE PRECAUTIONS

- (1) When you store LCDs for a long time, it is recommended to keep the temperature between 0°C ~40°C without the exposure of sunlight and to keep the humidity less than 90%RH.
- (2) Please do not leave the LCDs in the environment of high humidity and high temperature such as 60°C and 90%RH.
- (3) Please do not leave the LCDs in the environment of low temperature(below -20°C.)

10.5 SAFETY PRECAUTIONS

- (1) When you waste LCDs, it is recommended to crush damaged or unnecessary LCDs into pieces and wash them off with solvents such as acetone and ethanol, which should later be burned.
- (2) If any liquid leaks out of a damaged-glass cell and comes in contact with the hands, wash off thoroughly with soap and water.

10.6 OTHERS

- (1) A strong incident light into LCD panel might cause display characteristic changing inferior because of polarizer film, color filter, and other materials becoming inferior. Please do not expose LCD module direct sunlight and strong UV rays.
- (2) Please pay attention to a panel side of LCD module not to contact with other materials in preserving it alone.

(3) For the packaging box, please pay attention to the followings:

- Packaging box and inner case for LCD are designed to protect the LCDs from the damage or scratching during transportation. Please do not open except picking LCDs up from the box.
- Please do not pile them up more than 3 boxes. (They are not designed so.) And please do not turn over.
- Please handle packaging box with care not to give them sudden shock and vibrations. And also please do not throw them up.
- Packing box and inner case for LCDs are made of cardboard. So please pay attention not to get them wet. (Such like keeping them in high humidity or wet place can occur getting them wet.)