



Chunghwa Picture Tubes, Ltd. Technical Specification

To :

Date : 2002/3/12

CPT TFT-LCD

CLAA181XA01

ACCEPTED BY

APPROVED BY	CHECKED BY	PREPARED BY
		TFT-LCD Plant Application Dept.

Prepared by : TFT-LCD Application Department

CHUNGHWA PICTUER TUBES, LTD.

1127 Hopin Rd., Padeh, Taoyuan, Taiwan 334, R.O.C.

Doc.No:

Issue Date:

2002/03/12

1. OVERVIEW

CLAA181XA01 is 18.1" color TFT-LCD (Thin Film Transistor Liquid Crystal Display) module composed of LCD panel, driver ICs, control circuit and backlight.

By applying 8 bit digital data, 1024 768, 16.7M-color images are displayed on the 18.1" diagonal screen. Input power voltage is 5.0V for LCD driving.

Inverter for backlight is not included in this module. General specification are summarized in the following table:

ITEM	SPECIFICATION
Display Area(mm)	367.2(H)x275.4(V) (18.1-inch diagonal)
Number of Pixels	1024(H)x768(V)
Pixel Pitch(mm)	0.3585(H)x0.3585(V)
Color Pixel Arrangement	RGB vertical strip
Display Mode	normally white TN
Number of Colors	16.7M(8bits/color)
Brightness(cd/m ²)	350cd/m ² (Typ.)
Viewing Angle	-75~75(H), -60~50(V)(Typ.)
Surface Treatment	Anti-glare
Electrical Interface	CMOS(VIN=3~5V, 2 pixel/clock)
Total Module Power(W)	(Typ.)
Optimum Viewing Angle	6 o'clock
Module Size(mm)	422.0(H)x306.0"(H)x16.4"(D)
Module Weight(g)	2000
Backlight Unit	CCFL, 4 tables, edge-light(top/bottom)

The LCD Products listed on this document are not suitable for use of aerospace equipment, submarine cables, nuclear reactor control system and life support systems. If customers intend to use these LCD products for above application or not listed in "Standard" as follows, please contact our sales people in advance.

Standard: Computer, Office equipment, Communication equipment, Test and Measurement equipment, Machine tool, Industrial robot, Audio and Visual equipment, Other consumer products.

2. ABSOLUTE MAXIMUM RATINGS

ITEM	SYMBOL	MIN.	MAX.	UNIT
Power Supply Voltage for LCD	VCC	0	7.0	V
Logic Input Voltage	VI	-0.5	6.1	V
Lamp Voltage	VL	0	2500	Vrms
Lamp Current	IL	0	10.0	mArms
Lamp Frequency	FL	-	100	kHz
Operation Temperature *1)	Top	0	50	
Storage Temperature *1)	Tstg	-20	60	

Note:

*1) Humidity

Relative Humidity 90% (Ta 40)

Wet Bulb Temperature 40 (Ta 40)

3. ELECTRICAL CHARACTERISTICS

(a)TFT-LCD

ITEM	SYMBOL	MIN	TYP	MAX	UNIT	Remark
Power Supply Voltage for LCD	VCC	4.5	5.0	5.5	V	Note1
Power Supply Current for LCD	ICC	-	470	680	mA	Note2
Permissible Input Ripple Voltage	VRP	-	-	100	mVp-p	Vcc=5.0V
Input Threshold Voltage	High	VIH	2.2	3.3	V	
	Low	VIL	0	-	0.8	V

[Note 1]

VCC-turn-on conditions:

t_1 10ms $0 < t_4$ 50 ms 0 t_7
 $0 < t_2$ 10ms 1sec t_5
 $0 < t_3$ 1sec 200ms t_6

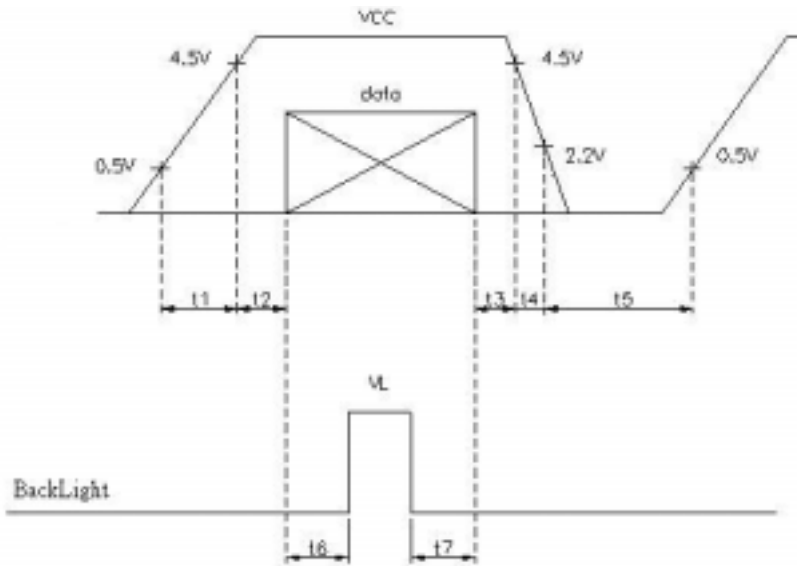

VCC-dip conditions

1)When $3.6V < VCC_{min}$

t_d 10 ms

2)When $3.6V > VCC_{min}$

VCC-dip conditions should also follow the VCC-turn-on conditions.

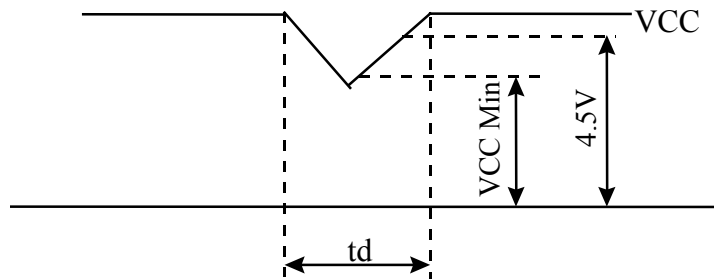

[Note 2] Typical current situation : 256-gray-bar pattern, 768 line mode, VCC=+5.0V

(b) Backlight

ITEM	SYMBOL	MIN	TYP	MAX	UNIT	REMARK
Lamp Voltage	VL	-	750	-	V	IL=6.0mA
Lamp Current	IL	5.0	(7.5)	8.0	mA	Note1
Interter Frequency	FL	45	-	70	kHz	Note2
Starting Lamp Voltage	VS	1700	-	-	V	Ta=0
		1500	-	-	V	Ta=25
Lamp life Time	LT	40000		-	hr	Note3 IL=7.0mA Continuous Operation

[Note 1]

Lamp Current measurement method (The current meter is inserted in cold line)

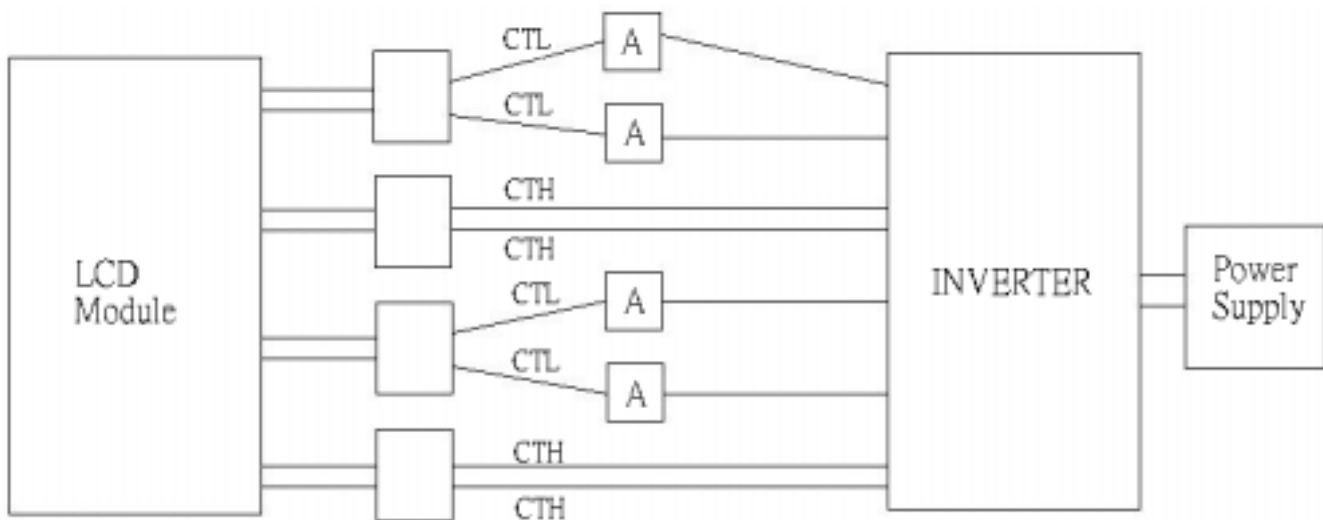

[Note 2]

Lamp frequency of inverter may produce interference with horizontal synchronous frequency, and this may cause horizontal beat on the display. Therefore, please adjust lamp frequency, and keep inverter as far from module as possible or use electronic shielding between inverter and module to avoid the interference.

4. INTERFACE PIN CONNECTION

(a) CN1(Data Signal and Power Supply)

Used connector:IL-FHR45S-HF(JAE)

Pin No	Symbol	Function
1	GND	
2	CLK	Dot clock
3	GND	
4	DENA	Data enable
5	GND	
6	VD	Vertical sync
7	GND	
8	HD	Horizontal sync
9	GND	
10	NC	(HMS)
11	GND	
12	BO7	Blue odd data(MSB)
13	BO6	Blue odd data
14	BO5	Blue odd data
15	BO4	Blue odd data
16	GND	
17	BO3	Blue odd data
18	BO2	Blue odd data
19	BO1	Blue odd data
20	BO0	Blue odd data(LSB)
21	GND	
22	GO7	Green odd data(MSB)
23	GO6	Green odd data
24	GO5	Green odd data
25	GO4	Green odd data
26	GND	
27	GO3	Green odd data
28	GO2	Green odd data
29	GO1	Green odd data
30	GO0	Green odd data(LSB)
31	GND	
32	RO7	Red odd data(MSB)
33	RO6	Red odd data
34	RO5	Red odd data
35	RO4	Red odd data
36	GND	
37	RO3	Red odd data
38	RO2	Red odd data
39	RO1	Red odd data
40	RO0	Red odd data(LSB)
41	VCC	
42	VCC	
43	TEST	Should be open during operation(Internal test only)
44	TEST	Should be open during operation(Internal test only)
45	TEST	Should be open during operation(Internal test only)

(b) CN2(Data Signal)

Used connector:IL-FHR-30S-HF(JAE)

Pin No.	Symbol	Function
1	GND	
2	BE7	Blue even data(MSB)
3	BE6	Blue even data
4	BE5	Blue even data
5	BE4	Blue even data
6	GND	
7	BE3	Blue even data
8	BE2	Blue even data
9	BE1	Blue even data
10	BE0	Blue even data(LSB)
11	GND	
12	GE7	Green even data(MSB)
13	GE6	Green even data
14	GE5	Green even data
15	GE4	Green even data
16	GND	
17	GE3	Green even data
18	GE2	Green even data
19	GE1	Green even data
20	GE0	Green even data(LSB)
21	GND	
22	RE7	Red even data(MSB)
23	RE6	Red even data
24	RE5	Red even data
25	RE4	Red even data
26	GND	
27	RE3	Red even data
28	RE2	Red even data
29	RE1	Red even data
30	RE0	Red even data(LSB)

(c)CN3,4(BACKLIGHT)

Backlight-side connector: BHSR-02VS-1

Inverter-side connector: SM02(4.0)B-BHS-1(JST)

Pin No.	Symbol	Function
1	CTH1	VBLH1(High voltage)
2	CTH2	VBLH2(High voltage)

(c)CN5,6(BACKLIGHT)

Backlight-side connector: BHR-02VS-1

Inverter-side connector: SM02B-BHSS-1(JST)

Pin No.	Symbol	Function
1	CTL1	VBLH(Low voltage)
2	CTL2	VBLH(Low voltage)

[Note]

VBLH-VBLL = VL

5. INTERFACE TIMING

(a) Timing Specifications

ITEM	SYMBOL	MIN	TYP	MAX	UNIT	
Clock DCLK *1) *4)	Frequency	f_{CLK}	30	32.5	40	MHz
	Period	t_{CLK}	25.0	30.8	33.3	ns
	Pulse Width(low)	t_{WCL}	0.475	0.5	0.525	t_{CLK}
	Pulse Width(high)	t_{WCH}	0.475	0.5	0.525	t_{CLK}
DATA*1) (R.G.B,DENA,HD,VD)	Set up Time	t_{Ds}	2.3	—	—	ns
	Hold Time	t_{Dh}	7.3	—	—	ns
DATA Enable DENA *3)	Low width	t_{WDL}	6	-	-	t_{CLK}
	Horizontal Front Porch	t_{HFP}	0	-	-	t_{CLK}
	Horizontal Back Porch	t_{HBP}	6	-	-	t_{CLK}
	Vertical Front Porch	t_{VFP}	0	-	-	tH
	Vertical Back Porch	t_{VBP}	4	-	-	tH
HD *2) *4)	Frequency	f_H	—	48.4	62.5	KHz
	Period	t_H	16	20.7	—	s
			582	672	-	t_{CLK}
	Pulse Width(low)	t_{WHL}	1	-	—	t_{CLK}
VD *2)	Frequency	f_V	55	60	75	Hz
	Period	t_V	13.3	16.7	18.2	ms
	Pulse Width(low)	t_{WVL}	1	6	—	tH

[Note]

- 1) Data is latched at fall edge of DCLK in this specification.
- 2) Polarities of HD and VD are negative in this specification.
- 3) DENA(Data Enable) should always be positive polarity as shown in the timing specification.
- 4) DCLK should appear during all blanking period, and HD should appear during blanking period of frame cycle.

(b) Timing Chart
 a. Pixel Timing Chart

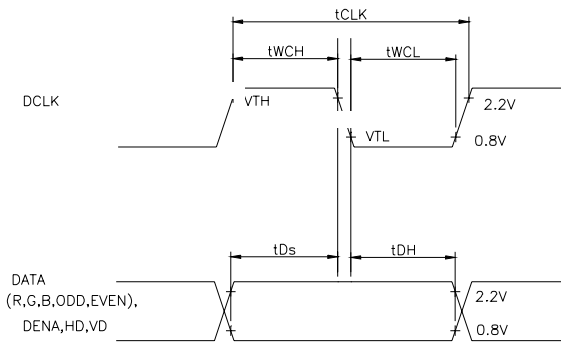

b. Horizontal Timing Chart

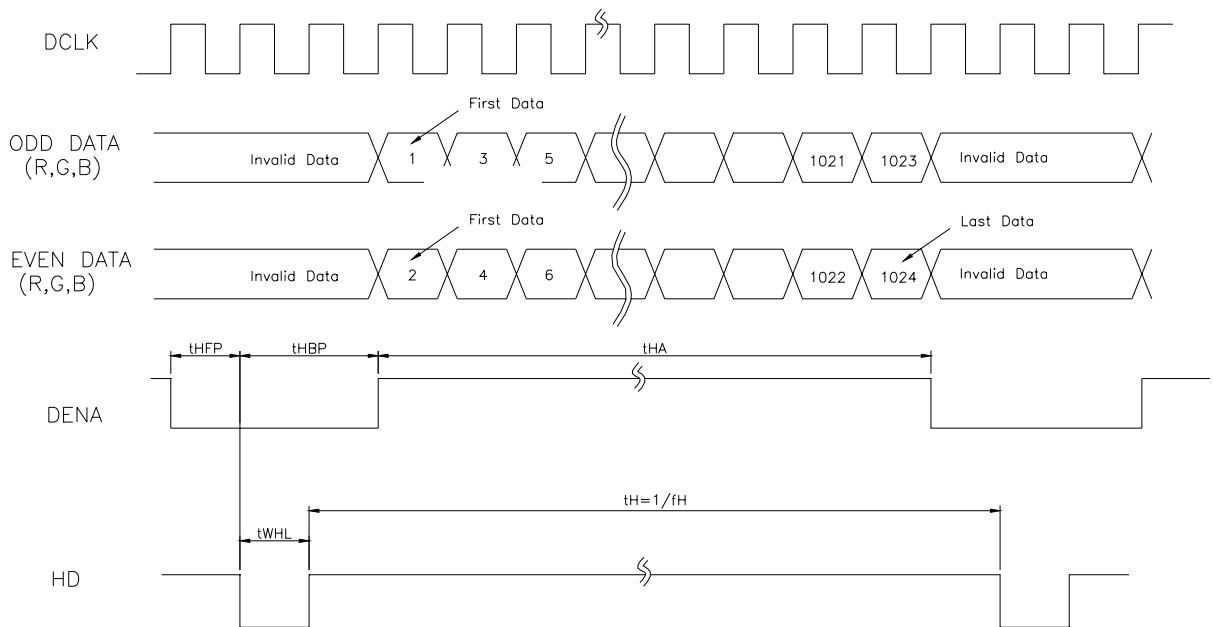

c. Vertical Timing Chart

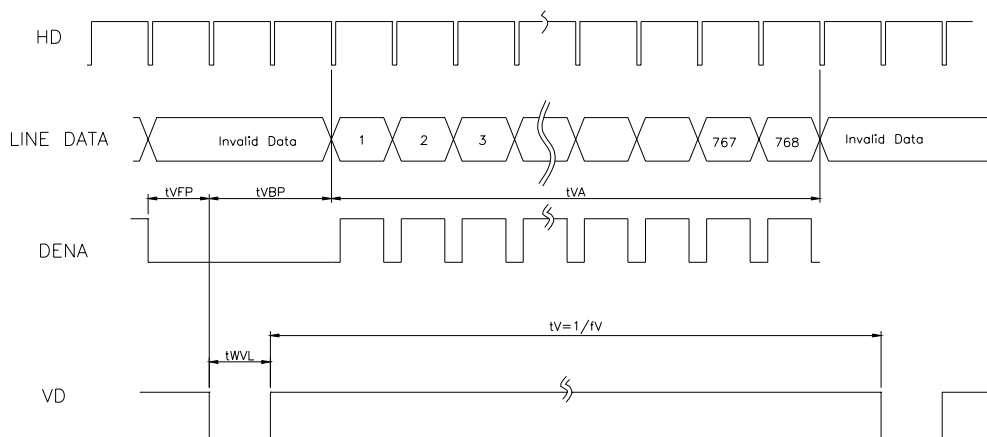

6. BLOCK DIAGRAM

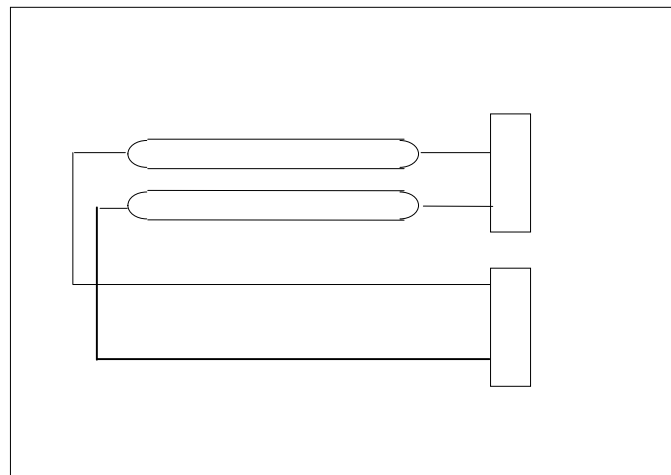
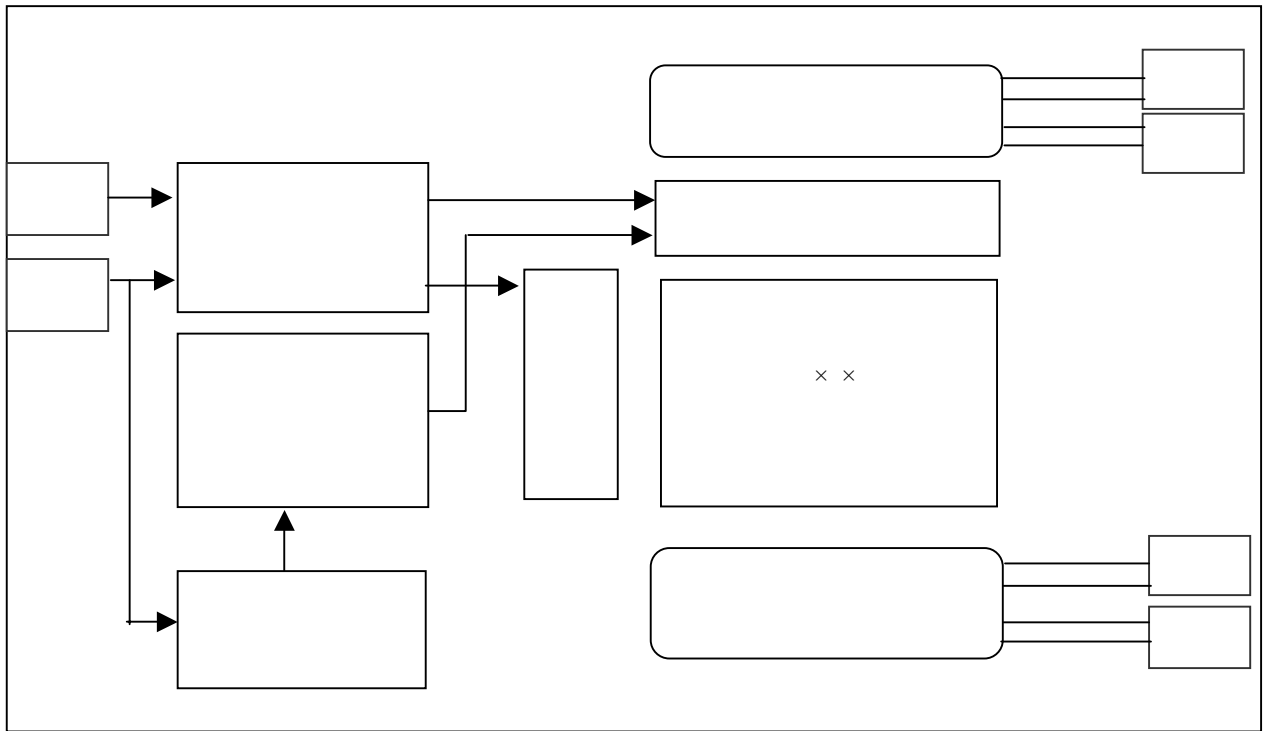

8.OPTICAL CHARACTERISTICS

VCC 5 0V

Ta 25

ITEM	SYMBOL	CONDITION	MIN.	TYP.	MAX.	UNIT	N	T
Contrast Ratio	C	ϕ 0	200	350	--	--		3
Luminance	Normal	ϕ 0	280	350	--	cd/m ²	2	3
	Uniformity	ϕ 0	--	--	30		2	3
Response Time (Black/White)	Tr	ϕ 0	--	6	--	ms	3	4
	Tf		--	9	--	ms	3	4
Response Time (Grayscale Transition)	Tr	ϕ 0	--	--	20	ms	3	4
	Tf		--	--	20	ms	3	4
Viewing Angle	Horizontal	ϕ	C 0	--	-75 75	--	°	3
	Vertical	θ		--	-60 50	--	°	3
Image sticking	tis	2hours	--	--	2	s		5
Color Coordinates	Red	y	ϕ 0	0.607 0.294	0.637 0.324	0.667 0.354	--	3
	Green	G Gy		0.230 0.566	0.260 0.596	0.290 0.626		
	Blue	B By		0.09 0.024	0.39 0.054	0.59 0.084		
	White	y		0.247 0.279	0.277 0.309	0.307 0.339		

[Note]

These items are measured using **CS-1000 (MINOLUTA)** OR **BM-5A(TOPCON)** under the dark room condition(no ambient light) after more than 30 minutes from turning on the lamp unless noted.

*) Condition: IL=7.5mA, Inverter Frequency=45kHz

Definition of these measurement items are as follows:

(1)Definition of Contrast Ratio

$$CR = \frac{ON(White)Luminance}{OFF(Black)Luminance}$$

(2)Definition of Luminance and (3)Definition of Viewing Angle(,)

Luminance uniformity

$$L = \frac{L(MAX)-L(MIN)}{L(MIN)} \times 100$$

Measure White Luminance on the below

5 points

MEASUREMENT POINTS

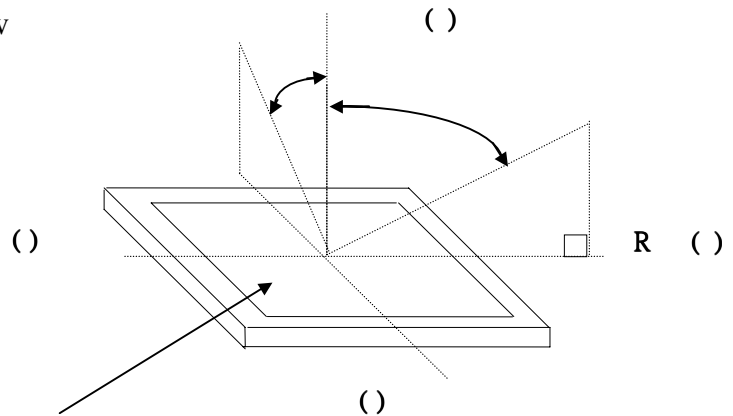
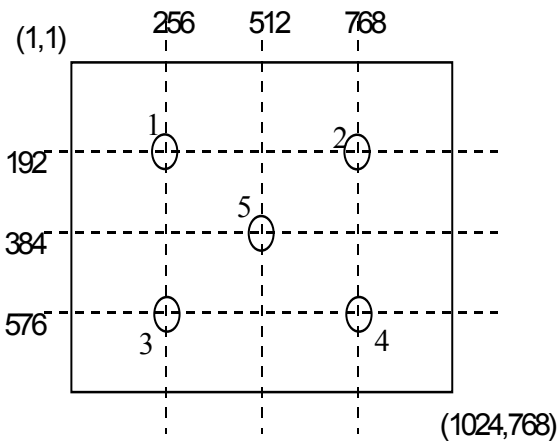

(4)Definition of Response Time

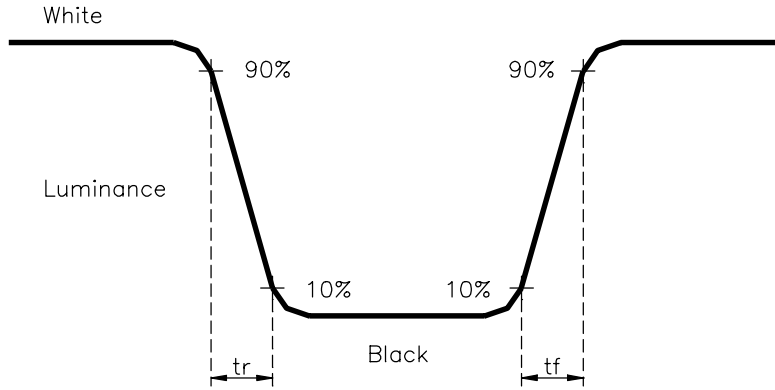

(5)Image sticking:

Continuously display the test pattern shown in the figure below for two-hours. Then display a completely white screen. The previous image shall not persist more than two seconds at 25 .

TEST PATTERN FOR IMAGE STICKING TEST

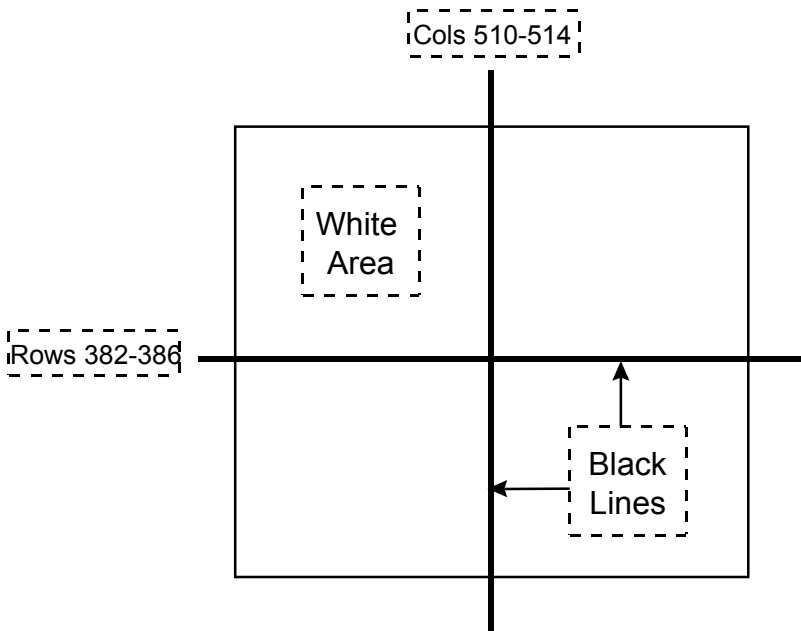

9.RELIABILITY TEST CONDITIONS

(1)Temperature and Humidity

TEST ITEMS	CONDITIONS
HIGH TEMPERATURE HIGH HUMIDITY OPERATION	40 ; 90%RH; 240h (No condensation)
HIGH TEMPERATURE OPERATION	50 ; 240h
LOW TEMPERATURE STORAGE	0 ; 240h
THERMAL SHOCK	BETWEEN -20 (1hr)AND 60 (1hr); 5 CYCLES
HIGH TEMPERATURE STORAGE	60 ; 240h
LOW TEMPERATURE OPERATION	-20 ; 240h

(2)Shock & Vibration

ITEMS	CONDITIONS
SHOCK (NON-OPERATION)	Shock level:980m/s ² (100G) Waveform: half sinusoidal wave, 2ms Number of shocks: one shock input in each direction of three mutually perpendicular axes for a total of six shock inputs
VIBRATION (NON-OPERATION)	Vibration level: 9.8m/s ² (1.0G) zero to peak Waveform: sinusoidal Frequency range: 5 to 500 Hz Frequency sweep rate: 0.5 octave/min Duration: one sweep from 5 to 500Hz in each of three mutually perpendicular axis(each x,y,z axis: 1 hour, total 3 hours)

(3)Judgment standard

The judgment of the above test should be made as follow:

Pass: Normal display image with no obvious non-uniformity and no line defect. Partial transformation of the module parts should be ignored.

Fail: No display image, obvious non-uniformity, or line defects.

3 PRECAUTIONS WITH ELECTROSTATICS

- (1) This LCD module uses CMOS-IC on circuit board and TFT-LCD panel, and so it is easy to be affected by electrostatics. Please be careful with electrostatics by the way of your body connecting to the ground and so on.
- (2) Please remove protection film very slowly on the surface of LCD module to prevent from electrostatics occurrence.

4 STORAGE PRECAUTIONS

- (1) When you store LCDs for a long time, it is recommended to keep the temperature between 0 ~40 without the exposure of sunlight and to keep the humidity less than 90%RH.
- (2) Please do not leave the LCDs in the environment of high humidity and high temperature such as 60 ~ 90%RH.
- (3) Please do not leave the LCDs in the environment of low temperature; below -20 .

5 SAFETY PRECAUTIONS

- (1) When you waste LCDs, it is recommended to crush damaged or unnecessary LCDs into pieces and wash them off with solvents such as acetone and ethanol, which should later be burned.
- (2) If any liquid leaks out of a damaged-glass cell and comes in contact with the hands, wash off thoroughly with soap and water.

6 OTHERS

- (1) A strong incident light into LCD panel might cause display characteristics' changing inferior because of polarizer film, color filter, and other materials becoming inferior. Please do not expose LCD module direct sunlight and strong UV rays.
- (2) Please pay attention to a panel side of LCD module not to contact with other materials in preserving it alone.
- (3) For the packaging box, please pay attention to the followings:
 - (3.1) Packaging box and inner case for LCD are designed to protect the LCDs from the damage or scratching during transportation. Please do not open except picking LCDs up from the box.
 - (3.2) Please do not pile them up more than 5 boxes. (They are not designed so.) And please do not turn over.
 - (3.3) Please handle packaging box with care not to give them sudden shock and vibrations. And also please do not throw them up.
 - (3.4) Packing box and inner case for LCDs are made of cardboard. So please pay attention not to get them wet. (Such like keeping them in high humidity or wet place can occur getting them wet.)