



Chunghwa Picture Tubes, Ltd.

Technical Specification

To : **Endrich**
Date : 20160804

CPT TFT-LCD
CLAA190EB01CW

APPROVED BY	CHECKED BY	PREPARED BY
Adam Liu	Joseph Chao	

Prepared by :

Automotive/IA Product Planning Management General Division
Product Planning Management & Developing Center

CHUNGHWA PICTURE TUBES, LTD.

1, Huaying RD., Sanho Tsun, Lungtan Shiang, Taoyuan, Taiwan 325, R.O.C.
TEL: +886-3-480-5678 FAX: +886-3-260-7389

Doc. No:		Issue Date:	2015/05/06
----------	--	-------------	------------

1. OVERVIEW

CLAA190EB01 is 19" color TFT-LCD (Thin Film Transistor Liquid Crystal Display) module composed of LCD panel, driver ICs, control circuit and backlight. By applying 8 bit digital data (6Bit+HFRC), 1280×1024, 16.7M-color images are displayed on the 19" diagonal screen.

General specifications are summarized in the following table:

ITEM	SPECIFICATION
Display Area(mm)	376.32(H) x 301.056(V) (19-inch diagonal)
Number of Pixels	1280(H) x 1024(V)
Pixel Pitch(mm)	0.294(H) x 0.294(V)
Color Pixel Arrangement	RGB vertical strip
Display Mode	Normally white, TN
Number of Colors	16.7M(6bits+Hi-FRC)
Brightness(cd/m ²)	450 (typ.)
Viewing Angle(H/V)	85/85/80/80(typ) ; 75/75/70/70(min) (CR>10)
Surface Treatment	Anti-Glare, 3H
Optimum Viewing Direction	6 O'clock(Max. contrast ratio, Gray level inversion)
Power consumption(W)	17W(typ.)
Interface Connection	LVDS 2ch
Module Size(mm)	396x324x15.18(typ)(W/ PWB)
Module Weight(g)	1500g(typ)
Backlight Unit	LED:(white-LED)

2. ABSOLUTE MAXIMUM RATINGS

ITEM	SYMBOL	MIN.	MAX.	UNIT	REMARK
Power Supply Voltage for LCD	VCC	0	6.0	V	
Logic Input Voltage	VI	0	6.0	V	
Backlight Power Supply Voltage	VLED	0	15	V	
Backlight ON-OFF Voltage	LED_EN	0	6	V	
Backlight Dimming Control Input Voltage	LED_PWM	0	6	V	
Operation Temperature	Top	-30	80	°C	1). 2). 3).
Storage Temperature	Tstg	-30	80	°C	1). 2). 3).

[Note]

- 1). The relative humidity and temperature range are as below sketch, 90%RH Max.
- 2). The maximum wet bulb temperature $\leq 39^{\circ}\text{C}$ and without dewing.
- 3). If you use the product in an environment which over the definition of temperature and humidity too long to effect the result of eye-etching.

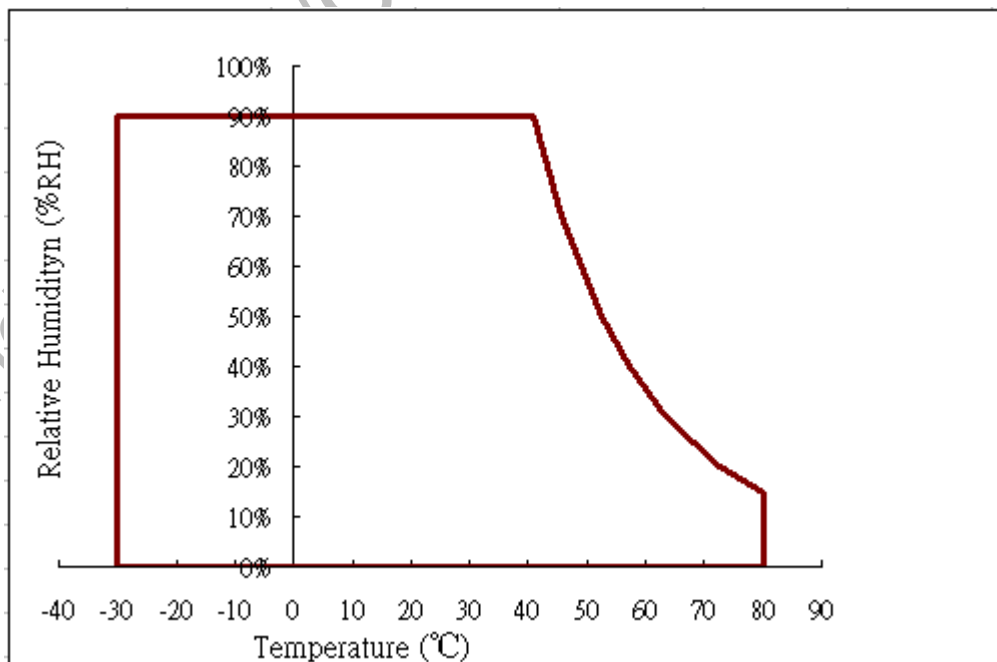

3. ELECTRICAL CHARACTERISTICS

(1).TFT-LCD

ITEM		SYMBOL	MIN	TYP	MAX	UNIT	NOTE
LCD Power Voltage		VCC	4.5	5.0	5.5	V	
LCD Power Current		ICC	-	1000	1200	mA	*1)
LCD Rush Current		VCC_Irush			2	A	*3)
Logic Input Voltage (LVDS: IN+,IN-)	Common Voltage	VCM	$\frac{ VID }{2}$	-	$2.4 - \frac{ VID }{2}$	V	Logic Input Voltage (LVDS: IN+,IN-)
	Differential Input Voltage	VID	200	-	600	mV	
	Threshold Voltage (HIGH)	VTH	-	-	100	mV	
	Threshold Voltage (LOW)	VTL	-100	-	-	mV	
Logic Input Voltage	VIH	0.7*DVDD	-	DVDD	V		Logic Input Voltage
	VIL	GND	-	0.3*DVDD	V		
Power consumption		P		5	6	W	
1 Data time		UI	-	tclk*1/7	-	tclk	*4)
LVDS clock to data skew		tskew	-	-	300	ps	
input data eye width		teyew	1516	-	-	ps	

【Note】

*1)TYP. specification : Gray-level test Pattern (TYP Freq. @5.0V)

MAX. specification : Black test Pattern (TYP Freq. @5.0V)

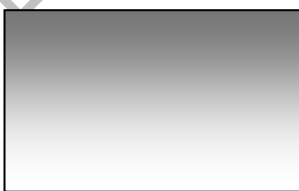

Gray-level Pattern

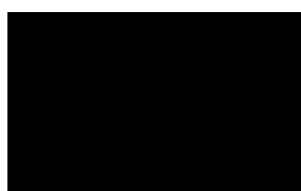

Black Pattern

*2) LVDS Signal Definite :

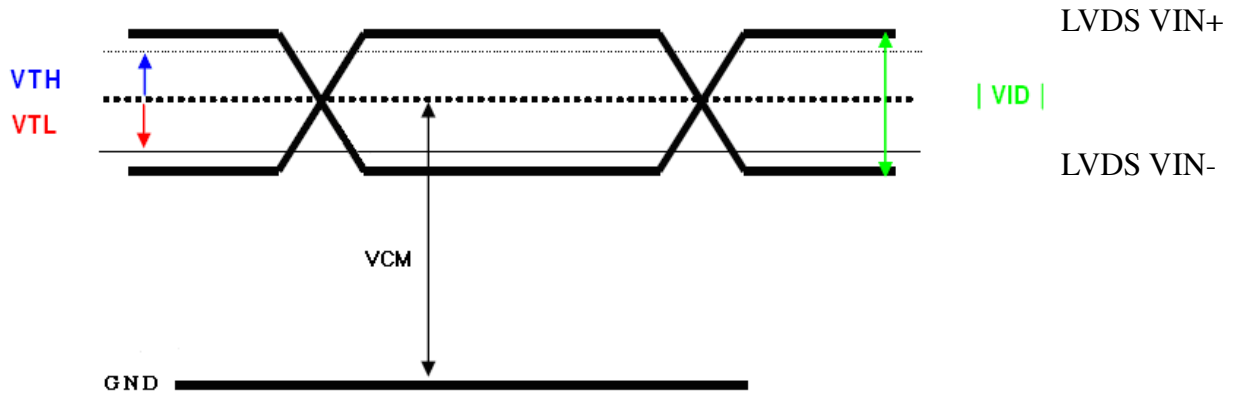

VIN+ : Positive differential DATA & CLK Input

VIN- : Negative differential DATA & CLK Input

*3) Irush measure condition

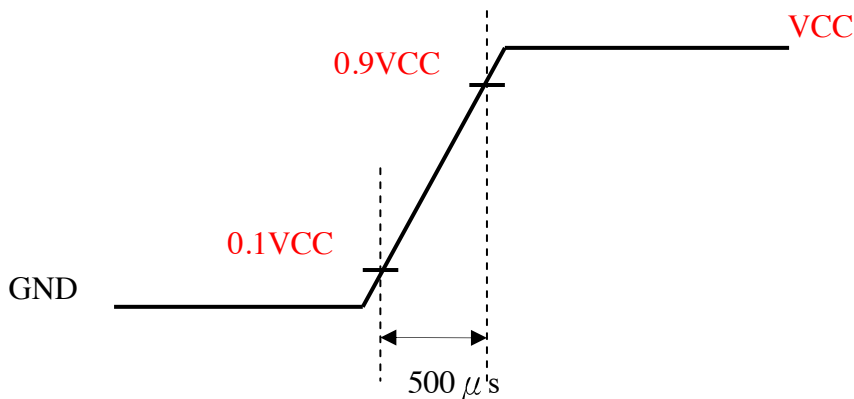
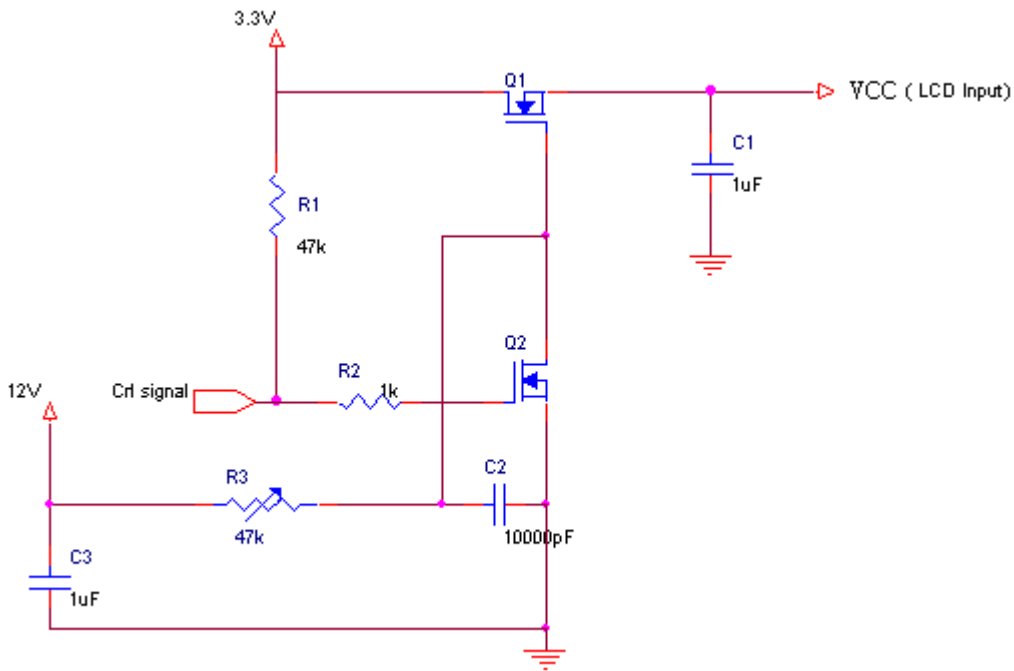

*4) Differential LVDS signal : The following conditon is base on operation frequency at MAX

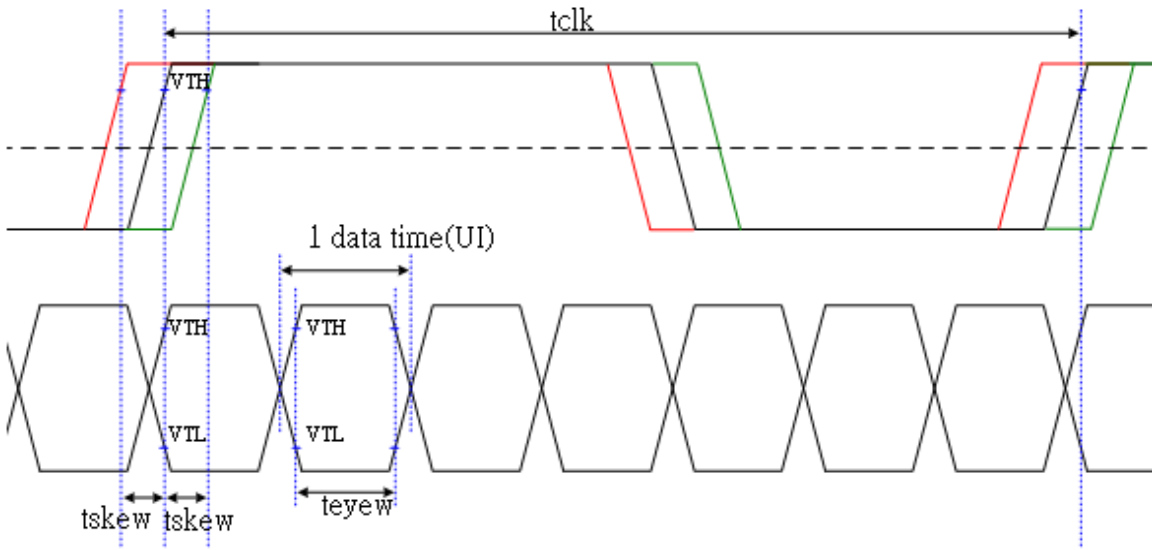

(2) Converter Specification for Backlight

Ta=25°C

ITEM	SYMBOL	MIN	TYP	MAX	UNIT	NOTE
LED Driver Input Voltage	VLED	10.8	12.0	13.2	V	
LED Driver Input Current	IVLED	-	1000	1200	mA	*1)
LED Rush Current	VLED_Irush			3	A	*3)
Dimming Control	High	2.4	--	5.5	V	Dimming Control
	Low	0		0.8		
PWM Frequency	LED_PWM	100	200	1K	Hz	*2)
Duty Ratio		5	-	100	%	
ON/OFF Control	High	2.4		5.5	v	ON/OFF Control
	Low	0		0.8		
Power Consumption (Backlight)	BLW	--	12	14.4	W	
LED Forward voltage (single LED)	VF	2.8	--	3.4	V	IF=95mA Ta=25°C
LED Forward current (single LED)	IF	--	95	--	mA	Ta=25°C
LIFE TIME (Backlight)		50000	70000		hr	*4)

*1) Maximum LED Driver Input Current at 10.8V Input Voltage/PWM Duty 100%.

*2) The ADJ adjust signal level is 0~5V , operation frequency:100Hz~1KHz ◦

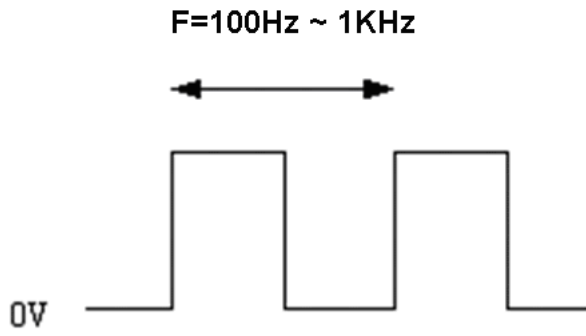

The ADJ can adjust LED BL brightness , where Duty and Luminance are in direct ratio.

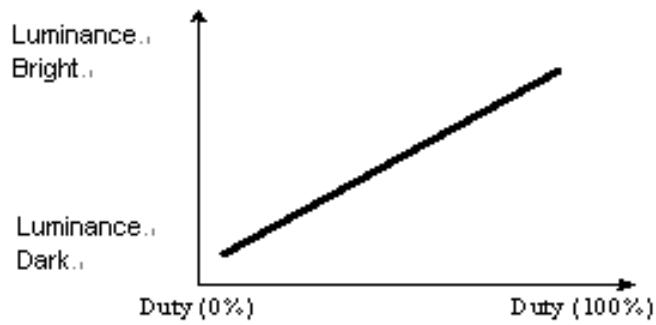

*3) Irush measure condition

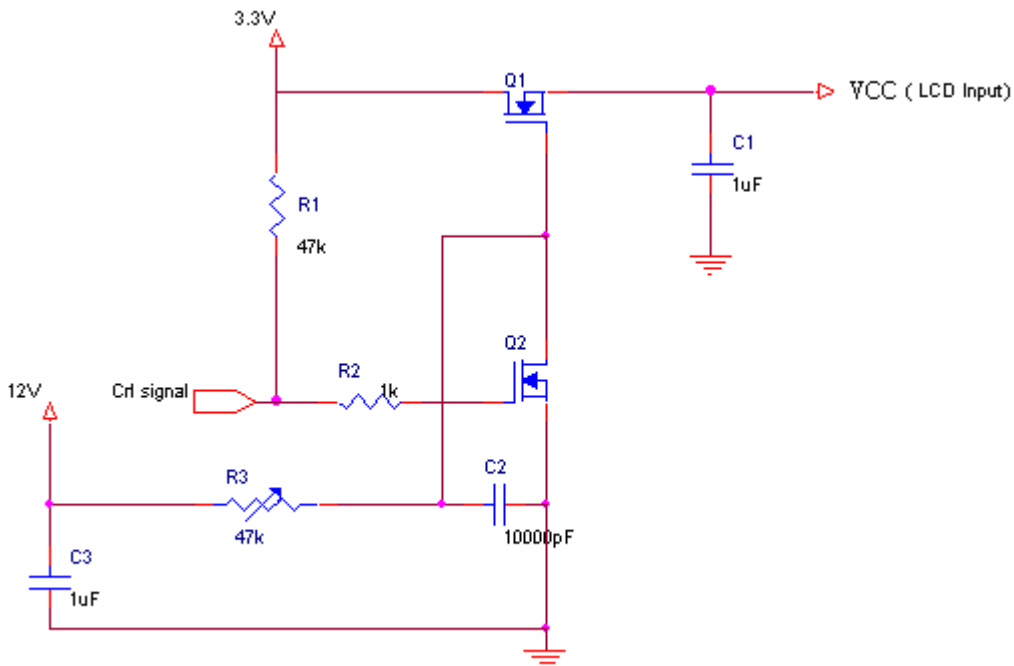

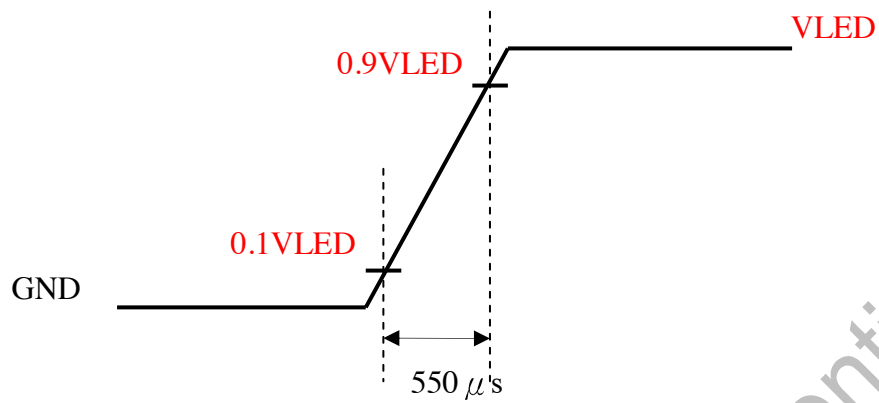

*4). Definition of the LED life time: Luminance (L) under 50% of the initial value. LED life time is restricted under normal condition, ambient temperature= 25°C and LED operation forward current= 95mA .

(3). Power and Signal sequence

Power Sequence :

- | | | |
|--|-------------------------|--------------------------|
| $0.50\text{ ms} \leq T1 \leq 10\text{ ms}$ | $200\text{ ms} \leq T3$ | $10\text{ ms} \leq T8$ |
| $0.01\text{ ms} < T2 \leq 50\text{ ms}$ | $10\text{ ms} \leq T5$ | $200\text{ ms} \leq T9$ |
| $0.50\text{ ms} \leq T4 \leq 10\text{ ms}$ | $10\text{ ms} \leq T6$ | $500\text{ ms} \leq T11$ |
| $0.01\text{ ms} < T10 \leq 50\text{ ms}$ | $0\text{ ms} \leq T7$ | |

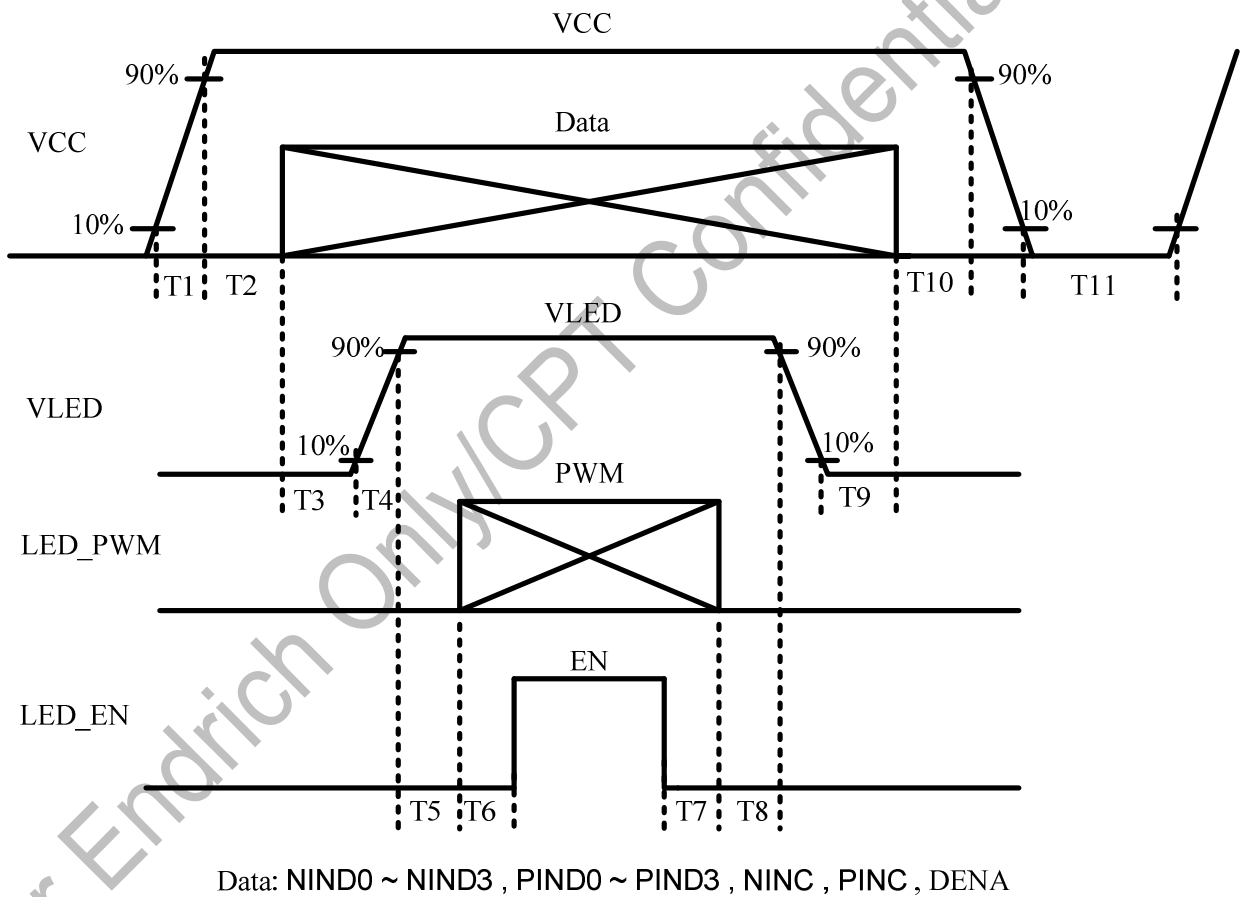

VCC-dip conditions:

- (1) When $3.6V \leq V_{cc}(\min) < 4.5V$: $t_d \leq 10\text{ ms}$
- (2) When $V_{cc} < 3.6V$, VCC-dip conditions should also follow the VCC-turn-on conditions.

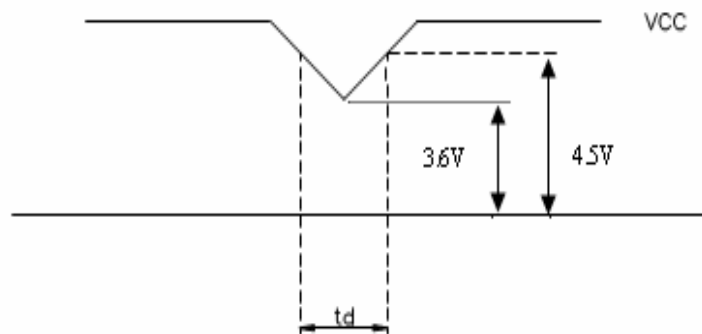

4. INTERFACE PIN CONNECTION

(1) CN1 (Data Signal and Power Supply)

Used connector: MSBKT2407P30HB (STM) or compatible

PIN NO.	SYMOBL	FUNCTION
1	RX00-	minus signal of odd channel 0(LVDS)
2	RX00+	plus signal of odd channel 0(LVDS)
3	RX01-	minus signal of odd channel 1(LVDS)
4	RX01+	plus signal of odd channel 1(LVDS)
5	RX02-	minus signal of odd channel 2(LVDS)
6	RX02+	plus signal of odd channel 2(LVDS)
7	GND	ground
8	RXOC-	minus signal of odd clock channel (LVDS)
9	RXOC+	plus signal of odd clock channel (LVDS)
10	RX03-	minus signal of odd channel 3(LVDS)
11	RX03+	plus signal of odd channel 3(LVDS)
12	RXE0-	minus signal of even channel 0(LVDS)
13	RXE0+	plus signal of even channel 0(LVDS)
14	GND	ground
15	RXE1-	minus signal of even channel 1(LVDS)
16	RXE1+	plus signal of even channel 1(LVDS)
17	GND	ground
18	RXE2-	minus signal of even channel 2(LVDS)
19	RXE2+	plus signal of even channel 2(LVDS)
20	RXEC-	minus signal of even clock channel (LVDS)
21	RXEC+	plus signal of even clock channel (LVDS)
22	RXE3-	minus signal of even channel 3(LVDS)
23	RXE3+	plus signal of even channel 3(LVDS)
24	GND	ground
25	GND	ground
26	GND	ground
27	GND	ground
28	VCC	Power supply input voltage(5.0 V)
29	VCC	Power supply input voltage(5.0 V)
30	VCC	Power supply input voltage(5.0 V)

- 1) Please keep the NC Pin and don't connect it to GND or other signals.
- 2) GND Pin must connect to the ground, don't let it be a vacant pin.

(2) CN2 (Backlight)

Used connector: **SM08B-GHH-TB**(JST) or compatible

PIN #	SYMBOL	FUNCTION
1	VLED	+12V Power Supply
2	VLED	+12V Power Supply
3	VLED	+12V Power Supply
4	GND	GND
5	GND	GND
6	GND	GND
7	LED_EN	ON : 5V / OFF: 0V (*1)
8	LED_PWM	Light Dimming Control : PWM Input for Dimming: L : 0V / H : 5V Freq : 100-1000Hz Duty : 5%-100%

*1) Enable High=5.5 to 2.4, Low=0 to 0.8V

5. INTERFACE TIMING

ITEM		SYMBOL	MIN	TYP	MAX	UNIT	
LCD Timing	DCLK	Frequency	f_{CLK}	44	54	67.5	MHz
		Period	t_{CLK}	14.81	18.52	22.2	ns
	DATA Enable DENA	Horizontal Active Time	t_{HA}	640			t_{CLK}
		Horizontal Blank Time	t_{HB}	140	204	-	t_{CLK}
		Horizontal Total Time	t_H	780	844	2047	t_{CLK}
		Vertical Active Time	t_{VA}	1024			tH
		Vertical Blank Time	t_{VB}	8	42	126	tH
		Vertical Total Time	t_V	1032	1066	1150	tH
Vertical Frame Rate	Fr	50	60	75	Hz		

(2) Timing Chart

a. Horizontal Timing

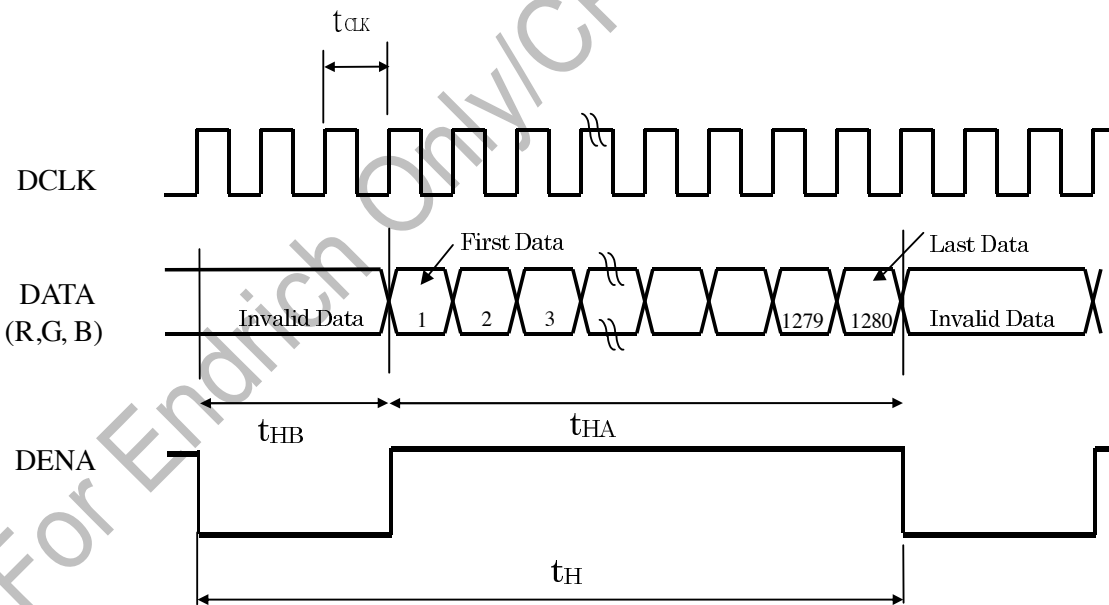

b. Vertical Timing

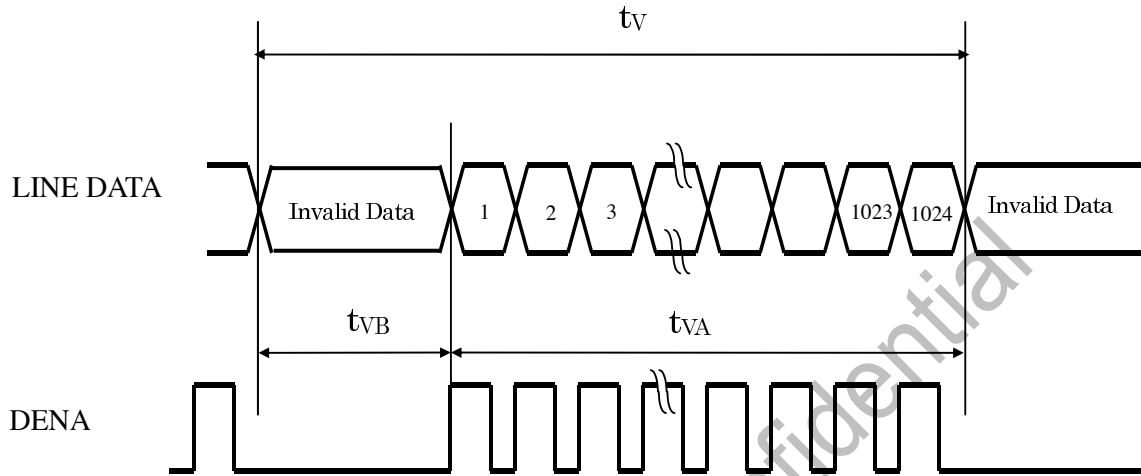

(3) LVDS DATA (VESA) : Timing Chart

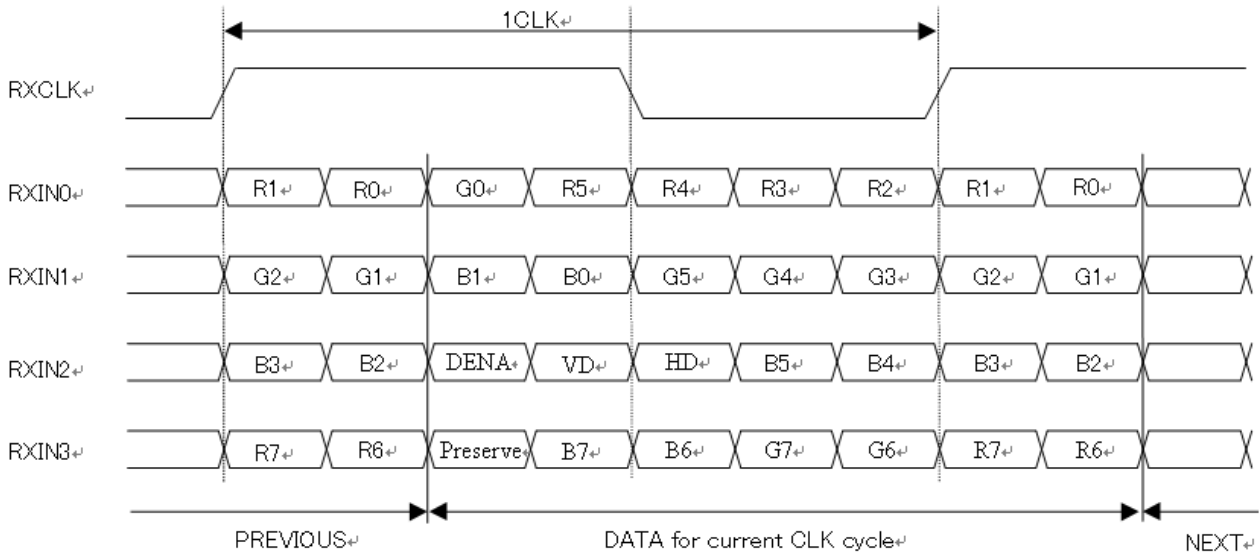

(4) Color Data Assignment

COLOR	INPUT DATA	R DATA								G DATA								B DATA							
		R7 MSB	R6	R5	R4	R3	R2	R1	R0 LSB	G7 MSB	G6	G5	G4	G3	G2	G1	G0 LSB	B7 MSB	B6	B5	B4	B3	B2	B1	B0 LSB
BASIC COLOR	BLACK	0	0	0	0	0	0	0	0	0	0	0	0	0	0	0	0	0	0	0	0	0	0	0	0
	RED(255)	1	1	1	1	1	1	1	1	1	0	0	0	0	0	0	0	0	0	0	0	0	0	0	
	GREEN(255)	0	0	0	0	0	0	0	0	0	1	1	1	1	1	1	0	0	0	0	0	0	0	0	
	BLUE(255)	0	0	0	0	0	0	0	0	0	0	0	0	0	0	0	1	1	1	1	1	1	1	1	
	CYAN	0	0	0	0	0	0	0	0	0	1	1	1	1	1	1	1	1	1	1	1	1	1	1	
	MAGENTA	1	1	1	1	1	1	1	1	0	0	0	0	0	0	0	0	1	1	1	1	1	1	1	
	YELLOW	1	1	1	1	1	1	1	1	1	1	1	1	1	1	1	0	0	0	0	0	0	0	0	
	WHITE	1	1	1	1	1	1	1	1	1	1	1	1	1	1	1	1	1	1	1	1	1	1	1	
RED	RED(0)	0	0	0	0	0	0	0	0	0	0	0	0	0	0	0	0	0	0	0	0	0	0		
	RED(1)	0	0	0	0	0	0	0	1	0	0	0	0	0	0	0	0	0	0	0	0	0	0		
	RED(2)	0	0	0	0	0	0	1	0	0	0	0	0	0	0	0	0	0	0	0	0	0	0		
	RED(254)	1	1	1	1	1	1	1	0	0	0	0	0	0	0	0	0	0	0	0	0	0	0		
	RED(255)	1	1	1	1	1	1	1	1	0	0	0	0	0	0	0	0	0	0	0	0	0	0		
GREEN	GREEN(0)	0	0	0	0	0	0	0	0	0	0	0	0	0	0	0	0	0	0	0	0	0	0		
	GREEN(1)	0	0	0	0	0	0	0	0	0	0	0	0	0	1	0	0	0	0	0	0	0	0		
	GREEN(2)	0	0	0	0	0	0	0	0	0	0	0	0	0	1	0	0	0	0	0	0	0	0		
	GREEN(254)	0	0	0	0	0	0	0	0	1	1	1	1	1	1	0	0	0	0	0	0	0	0		
	GREEN(255)	0	0	0	0	0	0	0	0	1	1	1	1	1	1	1	0	0	0	0	0	0	0		
BLUE	BLUE(0)	0	0	0	0	0	0	0	0	0	0	0	0	0	0	0	0	0	0	0	0	0	0		
	BLUE(1)	0	0	0	0	0	0	0	0	0	0	0	0	0	0	0	0	0	0	0	0	0	1		
	BLUE(2)	0	0	0	0	0	0	0	0	0	0	0	0	0	0	0	0	0	0	0	0	1	0		
	BLUE(254)	0	0	0	0	0	0	0	0	0	0	0	0	0	0	1	1	1	1	1	1	1	0		
	BLUE(255)	0	0	0	0	0	0	0	0	0	0	0	0	0	0	1	1	1	1	1	1	1	1		

[Note]

1) Definition of gray scale:

Color (n): n indicates gray scale level; higher n means brighter level.

2) Data: 1-High, 0-Low.

3) This assignment is applied to both odd and even data.

6. BLOCK DIAGRAM

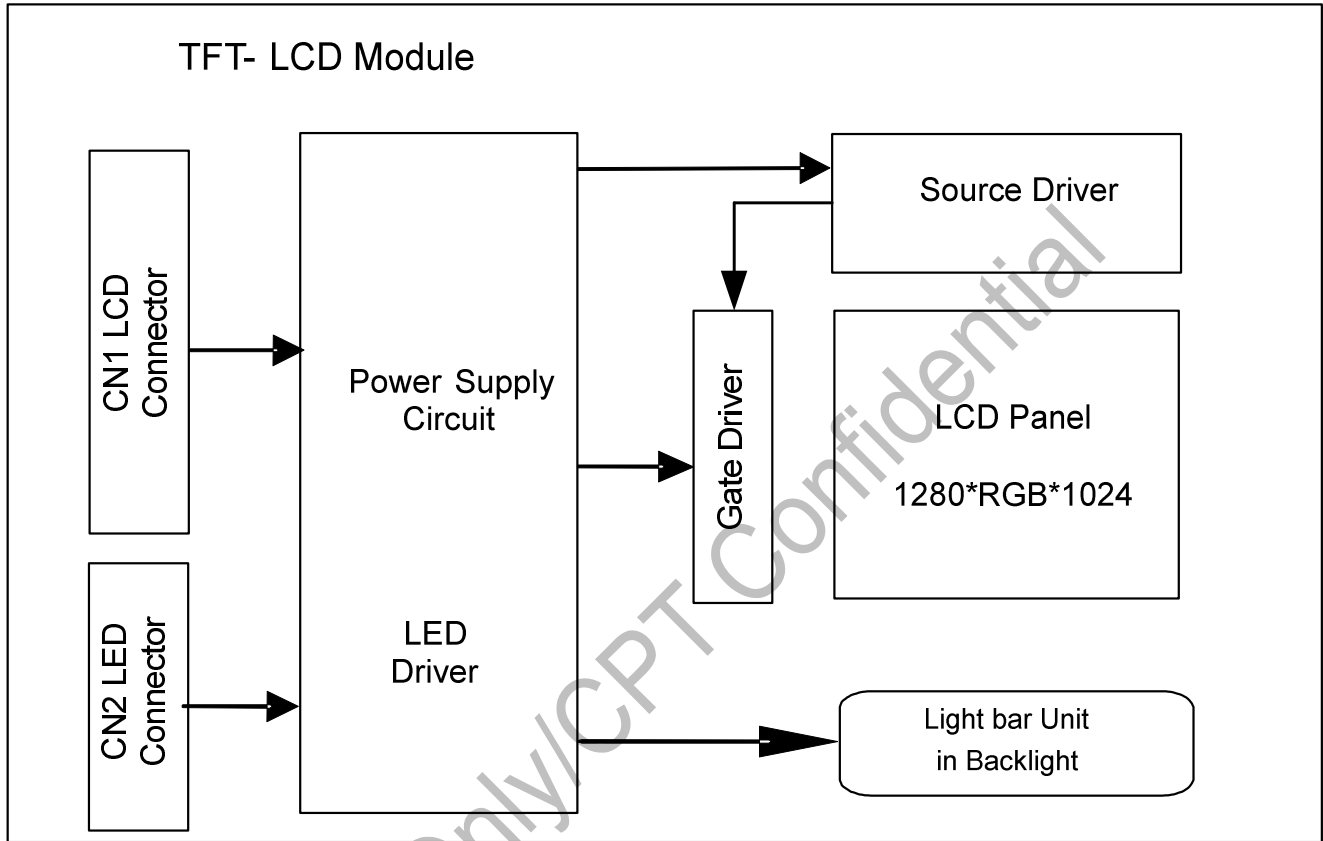

(2) Rear side (Tolerance is $\pm 0.5\text{mm}$ unless noted)

Unit: mm:

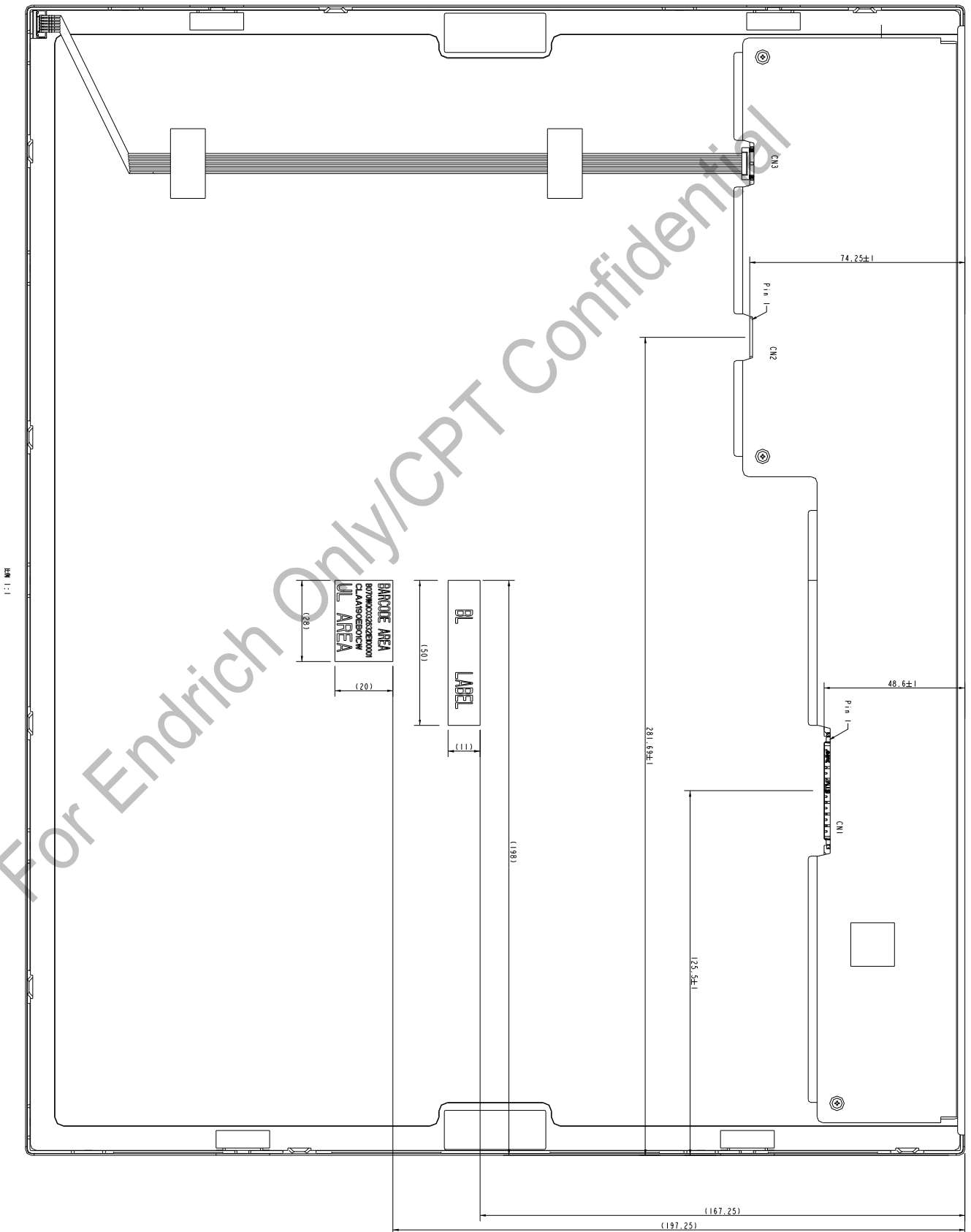

8. OPTICAL CHARACTERISTICS

Ta=25°C , VCC=3.3

ITEM	SYMBOL	CONDITION	min	typ	max	UNIT	REMARK	
Contrast Ratio	CR	$\theta = \psi = 0^\circ$	600	1000	--	--	*1) 2)	
Luminance(CEN)	L	$\theta = \psi = 0^\circ$	360	450	--	cd/m ²	*1) 3)	
9P Uniformity	ΔL	$\theta = \psi = 0^\circ$	75	80	--	%	*1) 3)	
Response Time	Tr+Tf	$\theta = \psi = 0^\circ$	--	16	--	ms	*5)	
Crosstalk	CT	$\theta = \psi = 0^\circ$	--	--	2	%	*6)	
Viewing Angle	Horizontal	ψ	$CR \geq 10$	-75~75	-85~85	--	Deg.	*4)
	Vertical	θ		-70~70	-80~80	--	Deg.	
Color Coordinates	White	X Y	$\theta = \psi = 0^\circ$	(0.263) (0.279)	(0.313) (0.329)	(0.363) (0.379)	*3)	
	Red	X Y		(0.576) (0.295)	(0.626) (0.345)	(0.676) (0.395)		
	Green	X Y		(0.248) (0.593)	(0.298) (0.643)	(0.348) (0.693)		
	Blue	X Y		(0.105) (0.010)	(0.155) (0.060)	(0.205) (0.110)		
Gamut	CG	$\theta = \psi = 0^\circ$	--	72	--	--	--	
Gamma	γ	VESA	2	2.2	2.4	--	*7)	
Image Sticking	Tis	4hr			5	min	*8)	

[Note]

Definition of these measurement items is as follows:

1) Setup of Measurement Equipment

The LCD module should be turn-on to a stable luminance level to be reached. The measurement should be executed after lighting Backlight for 20 minutes and in a dark room.

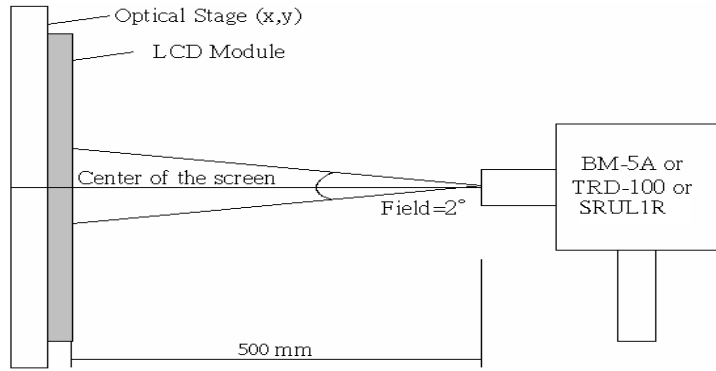

2).Definition of Contrast Ratio:

$CR = \text{ON (White) Luminance} / \text{OFF (Black) Luminance}$

3).Definition of Luminance and Luminance uniformity:

Center Luminance, &Color coordinate: measuring the luminance of the point no. 5

Average Luminance: measuring average luminance of points no.1-no.9

Uniformity: $\Delta L = [L (\text{Min}) / L (\text{Max})] \times 100 \%$

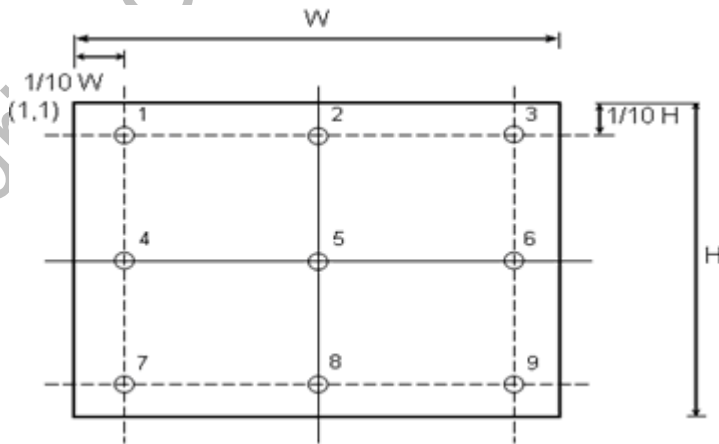

4).Definition of Viewing Angle (θ, ψ):

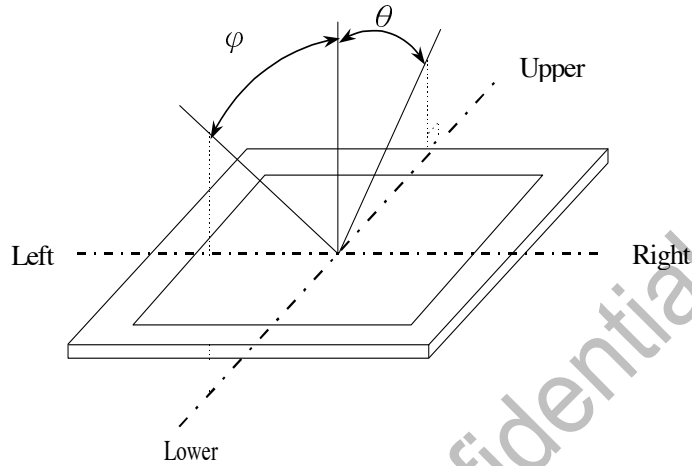

5) Definition of Response Time:

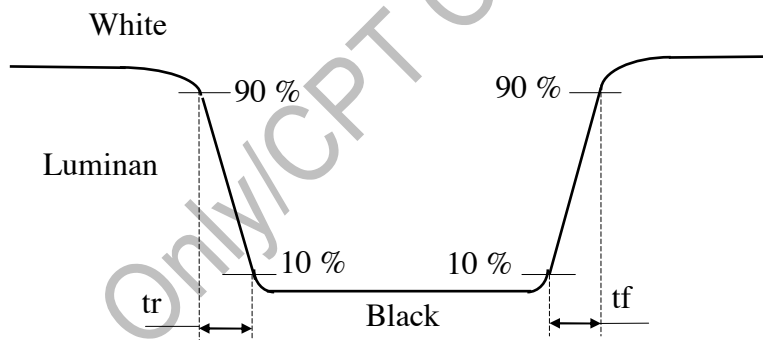

6) Definition of crosstalk:

$$CT = | Y_B - Y_A | / Y_A \times 100 (\%)$$

Y_A : The luminance of measured position at pattern A

Y_B : The luminance of measured position at pattern B with Gray level 0

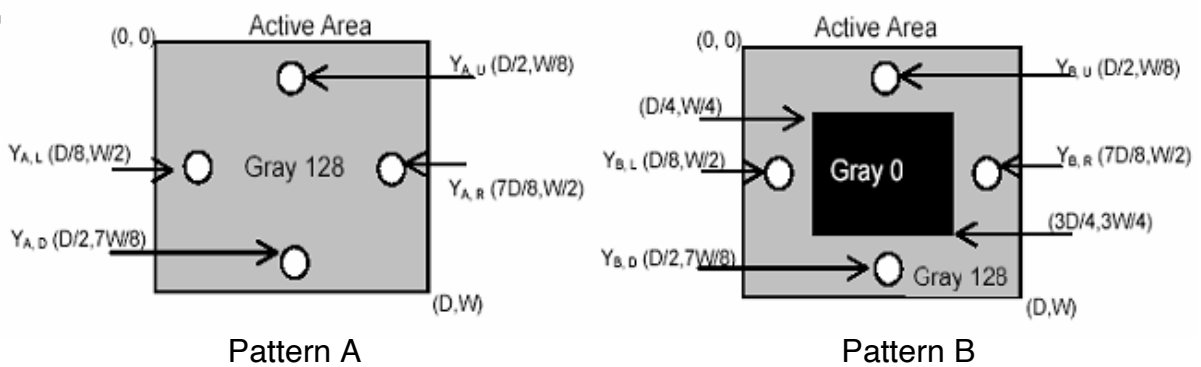

7) Definition of Gamma (γ), follow VESA standard sampling every 16 gray level (0,16,32,.....224,240,255)

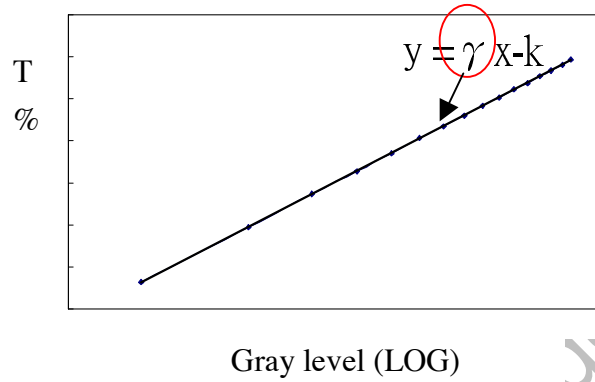

8) Image Sticking :

Condition of image sticking test: 25°C

Operation with test pattern sustained for 4hrs, then change to gray pattern immediately.

After 5 min, the Mura must be disappeared completely.

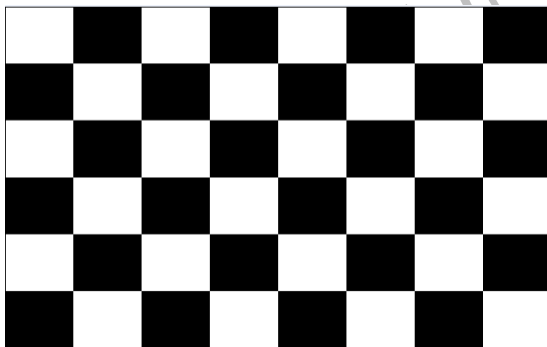

(a) Test Pattern(Chess Board Pattern)



(b) judgment Pattern(128 Gray Pattern)

9. RELIABILITY TEST CONDITIONS

(1) Temperature and Humidity

TEST ITEMS	CONDITIONS
High Temperature High Humidity Operation	50°C; 80%RH; 240hrs (no condensation)
High Temperature Operation	80°C; 240hrs
High Temperature Storage	80°C; 240hrs
Low Temperature Operation	-30°C; 240hrs
Low Temperature Storage	-30°C; 240hrs
Thermal Shock	Between -20°C(0.5hr) ~ 60°C(0.5hr); 50 Cycles

(2) Shock & Vibration

ITEMS	CONDITIONS
SHOCK (NON-OPERATION)	Shock level:(50G) Waveform: half sinusoidal wave, 20ms Number of shocks: one shock input in each direction of three mutually perpendicular axes for a total of six shock inputs
VIBRATION (NON-OPERATION)	Acceleration:1.5G Waveform: Random Frequency :10~200~10Hz Sweep:30Minute each Axis(X,Y,Z)

(3) ESD

POSITION	CONDITION(MDL turn off)
Connector	1. 200 pF , 0 Ω , ±200 V 2. contact mode for each pin
Module	1. 150 pF , 330 Ω , ±15K V (Air mode) , ±8K V (Contact mode) 2. Air mode, test 25 times for each test point 3. Contact mode, 25 times for each test point

(4) Judgment standard

The judgment of the above test should be made as follow:

Pass: Normal display image with no line defect.

Fail: No display image or line defects

10. WARRANTY

10.1 The period is within 12 months since the date of shipping out under normal using and storage conditions.

10.2 The warranty will be avoided in case of defect induced by customer.