



Chunghwa Picture Tubes, Ltd. Technical Specification

To :

Date :

CPT TFT-LCD

CLAA201VA07

ACCEPTED BY :

(TENTATIVE 1)

APPROVED BY	CHECKED BY	PREPARED BY
		TFT-LCD Product Planning Management General Division

CHUNGHWA PICTUER TUBES, LTD.

Doc.No:		Issue Date:	
---------	--	-------------	--

Revision History

Version	Page	Description

1. OVERVIEW

CLAA201VA07 is 20" color TFT-LCD (Thin Film Transistor Liquid Crystal Display) module composed of LCD Panel, Driver ICs, Control Circuit Board, Backlight. By applying 6 bit+FRC digital data, 640 × 480, 16.2M-color images are displayed on the 20" diagonal screen. Input power voltage is 5.0V for LCD driving and interface of data and control signals is CMOS. Inverter for backlight is not included in this module.

General specifications are summarized in the following table:

ITEM		SPECIFICATION
Display Area(mm)		408.0(H) × 306.0(V) (20.1 inch diagonal)
Number of Pixels		640×3(H) × 480(V)
Pixel Pitch(mm)		0.6375(H) × 0.6375(V)
Color Pixel Arrangement		RGB vertical strip
Display Mode		Normally White, TN
Number of Colors		16.2M (6Bit+FRC)
Optimum viewing angle		6 o'clock
Brightness(cd/m ²)		450(cd/m ²) @6.5mA
Response Time		12ms
Viewing Angle	CR ≥ 5	-85~85(H) , -85~85(V)
	CR ≥ 10	-80~80(H) , -65~70(V)
Wide Viewing Angle Technology		Super wide view film
Surface Treatment		Hard coating:3H ; Anti-glare
Electrical Interface		1CH -TTL interface
Total Module Power(W)		33.7W(Typ),BL 32W, Circuit 1.7W
Module Size(mm)		448.0(W) × 347.0(H) × 23.0(Max)(D)
Module Weight(g)		3800 (Typ.)
Backlight Unit		6 CCFLs side-lighting

2. ABSOLUTE MAXIMUM RATINGS

ITEM	SYMBOL	MIN.	MAX.	UNIT	REMARK
Power Supply Voltage for LCD	VCC	-0.3	6	V	
Voltage of Lamp	VL	-	1670	V _{rms}	
Current of Lamp	IL	2.0	7.0	mA _{rms}	
Frequency of Lamp	FL	40	80	kHz	
ESD(Static electricity)	VESDc	-250	250	V	Note1
	VESDm	-15K	15K	V	
Operation Temperature	Top	0	50	°C	
Storage Temperature	Tstg	-20	60	°C	

[Note1] Test condition : Follow IEC 1000-4-2:

VESDc : for Input connector's contact discharge ;

VESDm : for Module's contact discharge

3. ELECTRICAL CHARACTERISTICS

(a) TFT-LCD Ta=25°C

ITEM	SYMBOL	MIN	TYP	MAX	UNIT	REMARK
Power Supply Voltage for LCD	VCC	4.5	5.0	5.5	V	Note1
LCD Inrush current	I _{rush}	--	--	2	A	Note2
Power Supply Current for LCD	ICC	--	300	500	mA	Note3
Permissive Input Ripple Voltage	VRP	--	--	100	mVp-p	V _{cc} =5.0V
Logic Input Voltage	High	V _{IH}	3.0	3.3	3.6	V
	Low	V _{IL}	0	--	0.5	V

[Note 1] Power and signal sequence :

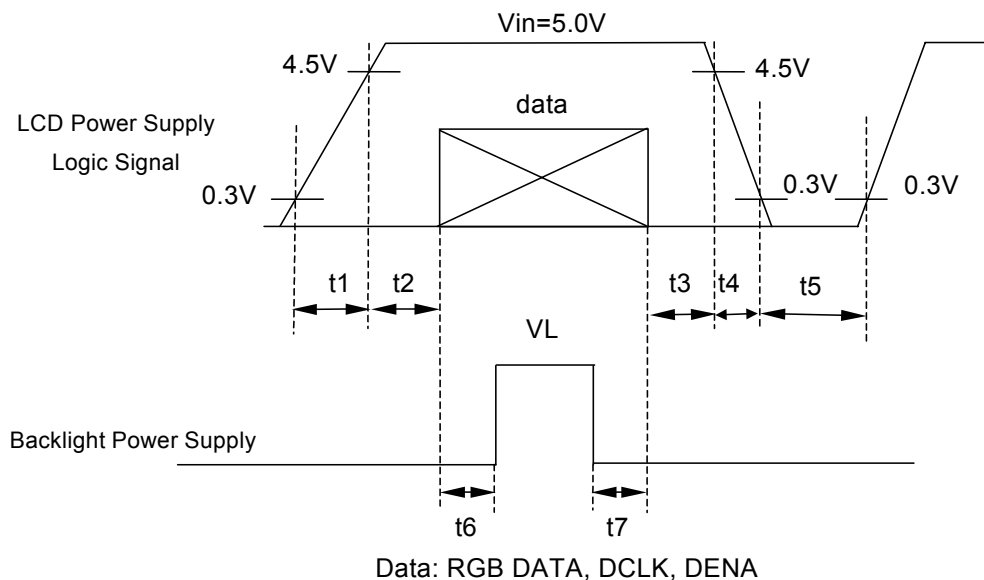

Data: RGB DATA, DCLK, DENA

$$\begin{aligned}
 0.5\text{ms} < t1 &\leq 10\text{ms} & 500\text{ms} &\leq t5 \\
 0 < t2 &\leq 50\text{ms} & 200\text{ms} &\leq t6 \\
 0 < t3 &\leq 50\text{ms} & 200\text{ms} &\leq t7 \\
 0 < t4 &\leq 10\text{ms} & &
 \end{aligned}$$

[Note 2] The system of measure input RUSH Current as below.

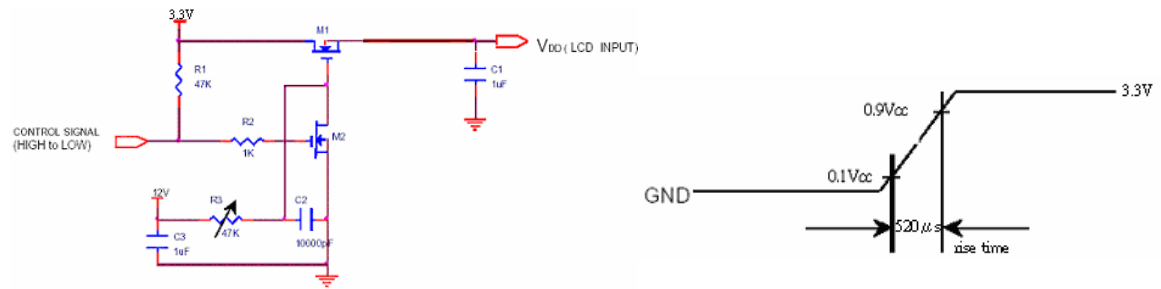

[Note 3] The system of measure Power Supply Current For LCD as below.

Test Conditional : $V_{CC}=5.0\text{ V}$, $f_{ih}=31.5\text{ kHz}$, $f_v=60\text{ Hz}$, $f_{clk}=25\text{ MHz}$

Test pattern :

(a) 256 gray level



(b) Backlight

Ta=25°C

ITEM	SYMBOL	MIN	TYP	MAX	UNIT	REMARK
Lamp Voltage	VL	--	805	--	Vrms	IL=6.5mA
Lamp Current	IL	2.0	6.5	7.0	mArms	Note1
Lamp Frequency	FI	50	55	60	kHz	Note2
Starting Lamp Voltage	VS	1480	--	--	Vrms	Ta=0°C
		1280	--	--	Vrms	Ta=25°C
Lamp life Time	LT	40,000	50,000	--	hr	IL=6.5mA Continuous Operation Note3

[Note]

If the driving waveform of lamp is asymmetric, the distribution of mercury inside the lamp tube will become unequal or will deplete the Ar gas in it. Then it may cause the abnormal phenomenon of lighting-up. Therefore, designers have to try their best to fill the conditions under the inverter designing-stage as below:

The degrees of unbalance: less than 10%

The ratio of wave height: less than $\sqrt{2} \pm 10\%$

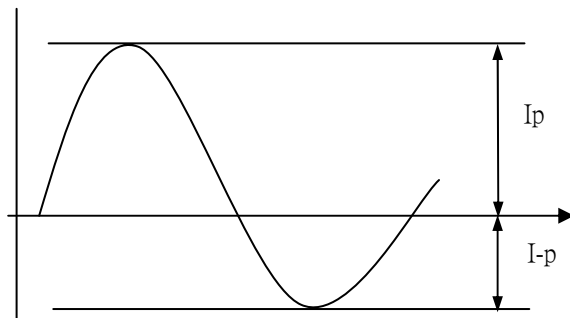

I_p : high side peak

$I-p$: low side peak

A : The degrees of unbalance = $| I_p - I-p | / I_{rms} \times 100 (\%)$

B : The ratio of wave height = I_p (or $I-p$) / I_{rms}

And need feedback for safe of protection hypothesis

[Note1] Measurement Method of Lamp Current (the current meter is inserted in low voltage line)

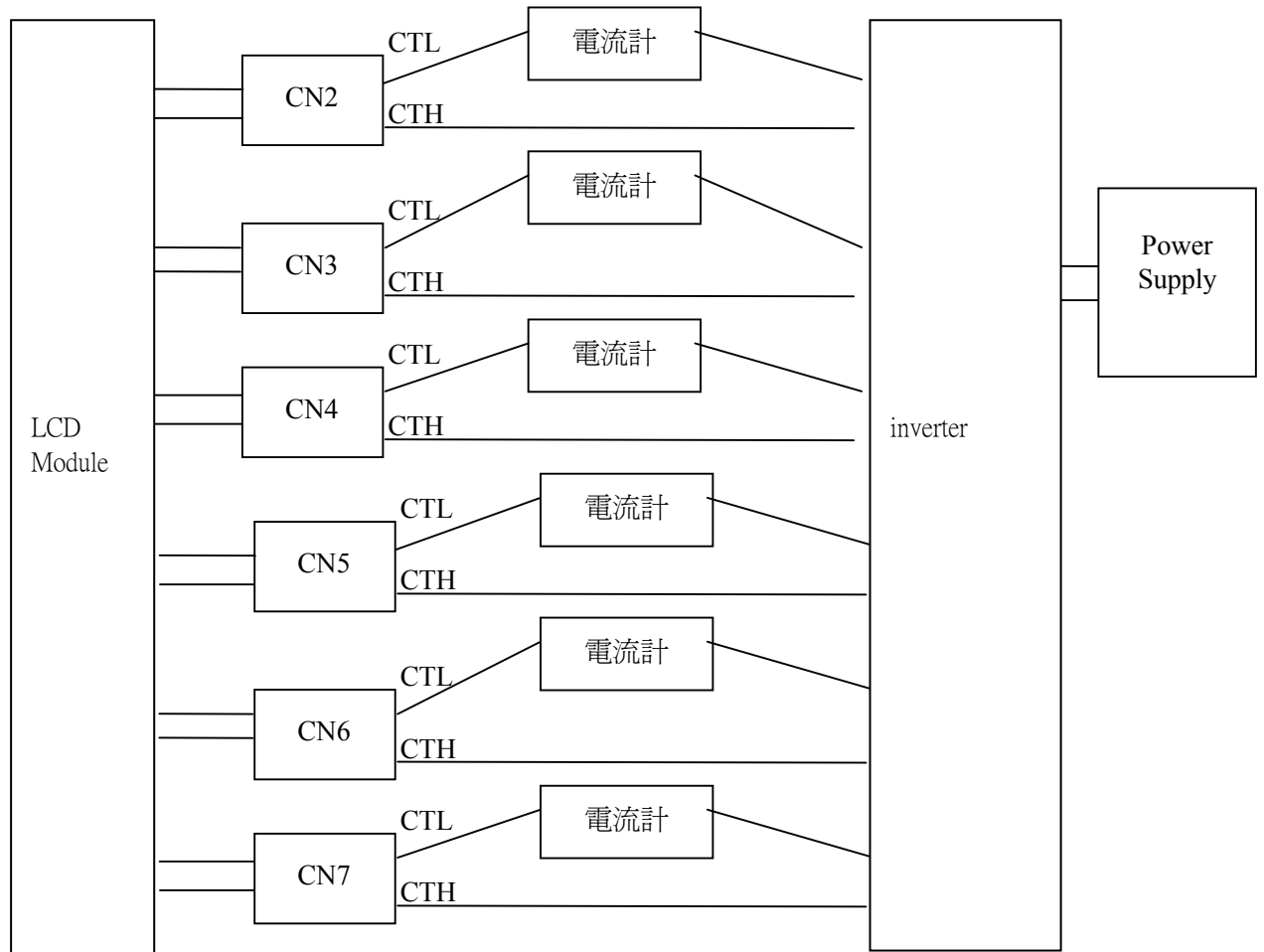

[Note2] The influence of lamp frequency

This frequency range can keep the electrical and optical character within $\pm 10\%$ variation. Lamp frequency may interfere with horizontal synchronous frequency (or vertical synchronous frequency), and then cause ripple noise on the display. Therefore, please adjust the frequency of lamp input, be removed inverter from module as possible, or use electronic shielding between inverter and module to avoid the interference.

[Note3] Definition of the lamp life the luminance reduced to 50% of initial value.

4. INTERFACE PIN CONNECTION

(a) CN1(TFT-LCD signal)

Used connector: AF7506-N2G11

Number	Symbol	Function
1	TEST	Should be open during operation (Internal test only)
2	TEST	Should be open during operation (Internal test only)
3	TEST	Should be open during operation (Internal test only)
4	GND	Ground
5	GND	Ground
6	VCC	5V
7	VCC	5V
8	VCC	5V
9	VCC	5V
10	GND	Ground
11	HD	Horizontal sync
12	VD	Vertical sync
13	GND	Ground
14	DENA	Data Enable
15	GND	GND
16	CLK	Dot Clock
17	GND	Ground
18	R7	Red data (MSB)
19	R6	Red data
20	R5	Red data
21	R4	Red data
22	GND	Ground
23	R3	Red data
24	R2	Red data
25	R1	Red data
26	R0	Red data
27	GND	Ground
28	G7	Green data
29	G6	Green data
30	G5	Green data
31	G4	Green data
32	GND	Ground
33	G3	Green data
34	G2	Green data
35	G1	Green data
36	G0	Green data
37	GND	Ground
38	B7	Blue data
39	B6	Blue data
40	B5	Blue data
41	B4	Blue data
42	GND	Ground
43	B3	Blue data
44	B2	Blue data
45	B1	Blue data
46	B0	Blue data (LSB)
47	GND	Ground
48	GND	Ground
49	NC	NC
50	NC	NC

(b) CN2~7(Backlight)

Backlight-side connector CN2, 3, 4, 5, 6, 7: BHSR-02VS-1(JST)

Inverter-side connector : SM02B-BHSS-1(JST)

Pin No.	Symbol	Function
1	CTH	VBLH (High voltage)
2	CTL	VBLL (Low voltage)

[Note] VBLH-VBLL=VL

5. INTERFACE TIMING

(a)Timing Specifications

ITEM	SYMBOL	MIN	TYP	MAX	UNIT	Note	
Clock	Frequency	1/Tclk	20	25	30.5	MHz	
Vertical Section	Frame Rate	Fr	50	60	72	Hz	
	Vertical Total	Tv	495	525	570	Th	Tv= Tvd+ Tvb
	Vertical Valid	Tvd	480	480	480	Th	
	Vertical Blank	Tvb	15	45	90	Th	
Horizontal Section	Horizontal Total	Th	718	800	850	Tclk	Th= Thd+ Thb
	Horizontal Valid	Thd	640	640	640	Tclk	
	Horizontal Blank	Thb	78	160	210	Tclk	

[Note] 1) This module is operated by DE only mode.

(b)Timing Chart

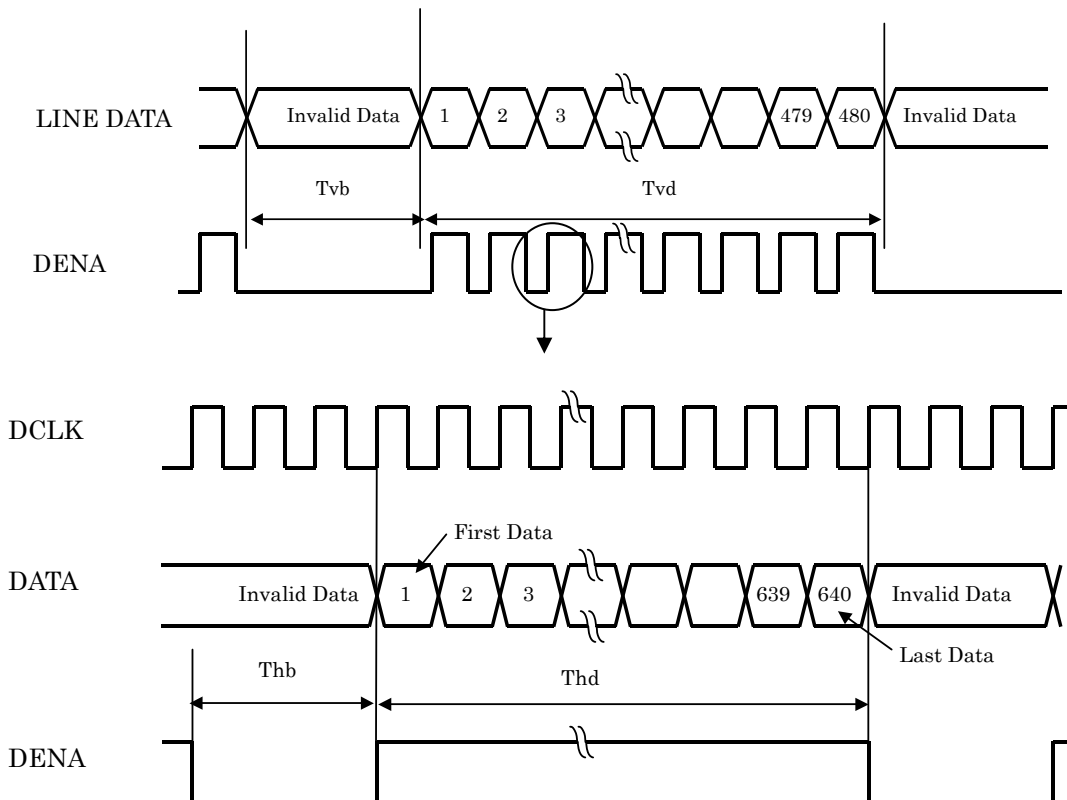

(c)Color Data Assignment

COLOR	INPUT DATA	R DATA									G DATA								B DATA							
		R7	R6	R5	R4	R3	R2	R1	R0	G7	G6	G5	G4	G3	G2	G1	G0	B7	B6	B5	B4	B3	B2	B1	B0	
		MSB						LSB			MSB						LSB			MSB						LSB
BASIC COLOR	BLACK	0	0	0	0	0	0	0	0	0	0	0	0	0	0	0	0	0	0	0	0	0	0	0	0	
	RED(255)	1	1	1	1	1	1	1	1	0	0	0	0	0	0	0	0	0	0	0	0	0	0	0	0	
	GREEN(255)	0	0	0	0	0	0	0	0	1	1	1	1	1	1	1	1	0	0	0	0	0	0	0	0	
	BLUE(255)	0	0	0	0	0	0	0	0	0	0	0	0	0	0	0	0	1	1	1	1	1	1	1	1	
	CYAN	0	0	0	0	0	0	0	0	1	1	1	1	1	1	1	1	1	1	1	1	1	1	1	1	
	MAGENTA	1	1	1	1	1	1	1	1	0	0	0	0	0	0	0	0	1	1	1	1	1	1	1	1	
	YELLOW	1	1	1	1	1	1	1	1	1	1	1	1	1	1	1	1	0	0	0	0	0	0	0	0	
WHITE	1	1	1	1	1	1	1	1	1	1	1	1	1	1	1	1	1	1	1	1	1	1	1	1		
RED	RED(0)	0	0	0	0	0	0	0	0	0	0	0	0	0	0	0	0	0	0	0	0	0	0	0	0	
	RED(1)	0	0	0	0	0	0	0	1	0	0	0	0	0	0	0	0	0	0	0	0	0	0	0	0	
	RED(2)	0	0	0	0	0	0	1	0	0	0	0	0	0	0	0	0	0	0	0	0	0	0	0	0	
	RED(254)	1	1	1	1	1	1	1	0	0	0	0	0	0	0	0	0	0	0	0	0	0	0	0	0	
	RED(255)	1	1	1	1	1	1	1	1	0	0	0	0	0	0	0	0	0	0	0	0	0	0	0	0	
GREEN	GREEN(0)	0	0	0	0	0	0	0	0	0	0	0	0	0	0	0	0	0	0	0	0	0	0	0	0	
	GREEN(1)	0	0	0	0	0	0	0	0	0	0	0	0	0	0	1	0	0	0	0	0	0	0	0	0	
	GREEN(2)	0	0	0	0	0	0	0	0	0	0	0	0	0	1	0	0	0	0	0	0	0	0	0		
	GREEN(254)	0	0	0	0	0	0	0	0	1	1	1	1	1	1	0	0	0	0	0	0	0	0	0	0	
	GREEN(255)	0	0	0	0	0	0	0	0	1	1	1	1	1	1	1	0	0	0	0	0	0	0	0		
BLUE	BLUE(0)	0	0	0	0	0	0	0	0	0	0	0	0	0	0	0	0	0	0	0	0	0	0	0	0	
	BLUE(1)	0	0	0	0	0	0	0	0	0	0	0	0	0	0	0	0	0	0	0	0	0	0	0	1	
	BLUE(2)	0	0	0	0	0	0	0	0	0	0	0	0	0	0	0	0	0	0	0	0	0	0	1	0	
	BLUE(254)	0	0	0	0	0	0	0	0	0	0	0	0	0	0	0	0	1	1	1	1	1	1	1	0	
	BLUE(255)	0	0	0	0	0	0	0	0	0	0	0	0	0	0	0	0	1	1	1	1	1	1	1	1	

1) Definition of gray scale:

Color(n) : n indicates gray scale level.

Higher n means brighter level.

2) Data:1-High,0-Low.

3) This assignment is applied to both odd and even data.

(d) Data Mapping

D(1, 1)	D(2, 1)	---	D(X, 1)	---	D(639, 1)	D(640, 1)
D(1, 2)	D(2, 2)	---	D(X, 2)	---	D(639, 2)	D(640, 2)
		+		+		
D(1, Y)	D(2, Y)	---	D(X, Y)	---	D(639, Y)	D(640, Y)
		+		+		
D(1,479)	D(2,479)	---	D(X,479)	---	D(639,479)	D(640,479)
D(1,480)	D(2,480)	---	D(X,480)	---	D(639,480)	D(640,480)

6. BLOCK DIAGRAM

(a) TFT-LCD Module

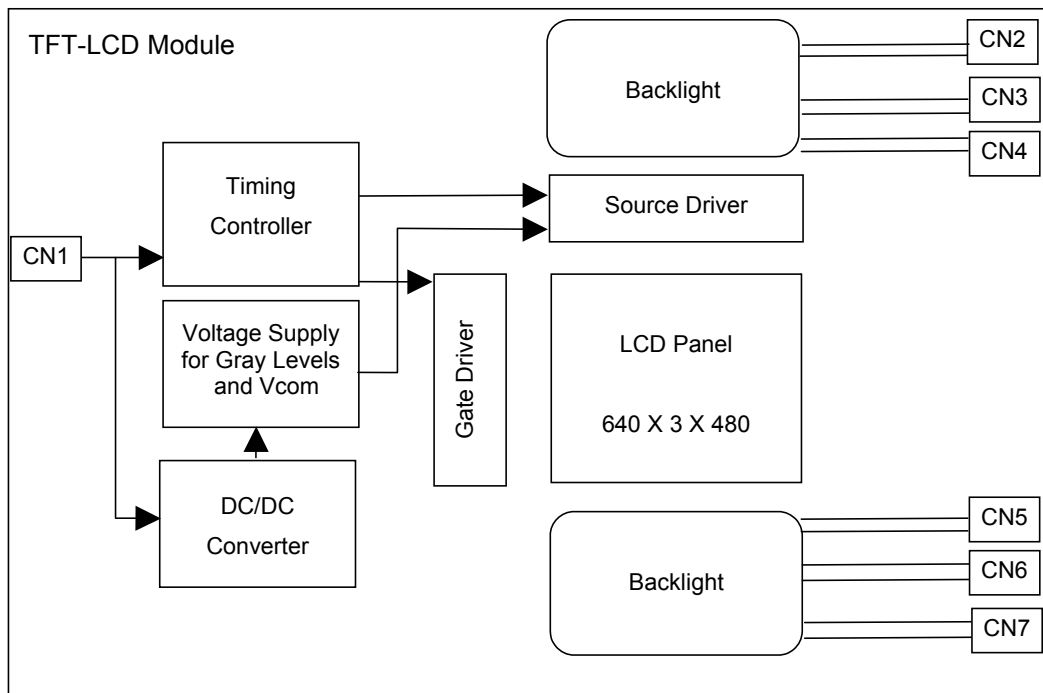

BACKLIGHT

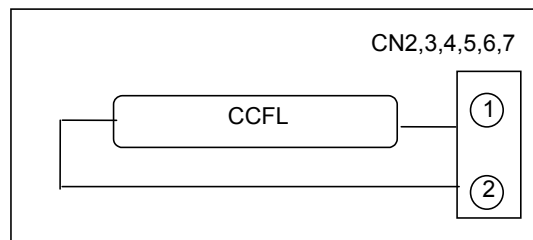

7. MECHANICAL SPECIFICATION

(a) Front side (Tolerance is $\pm 0.5\text{mm}$ unless noted)

Unit: mm

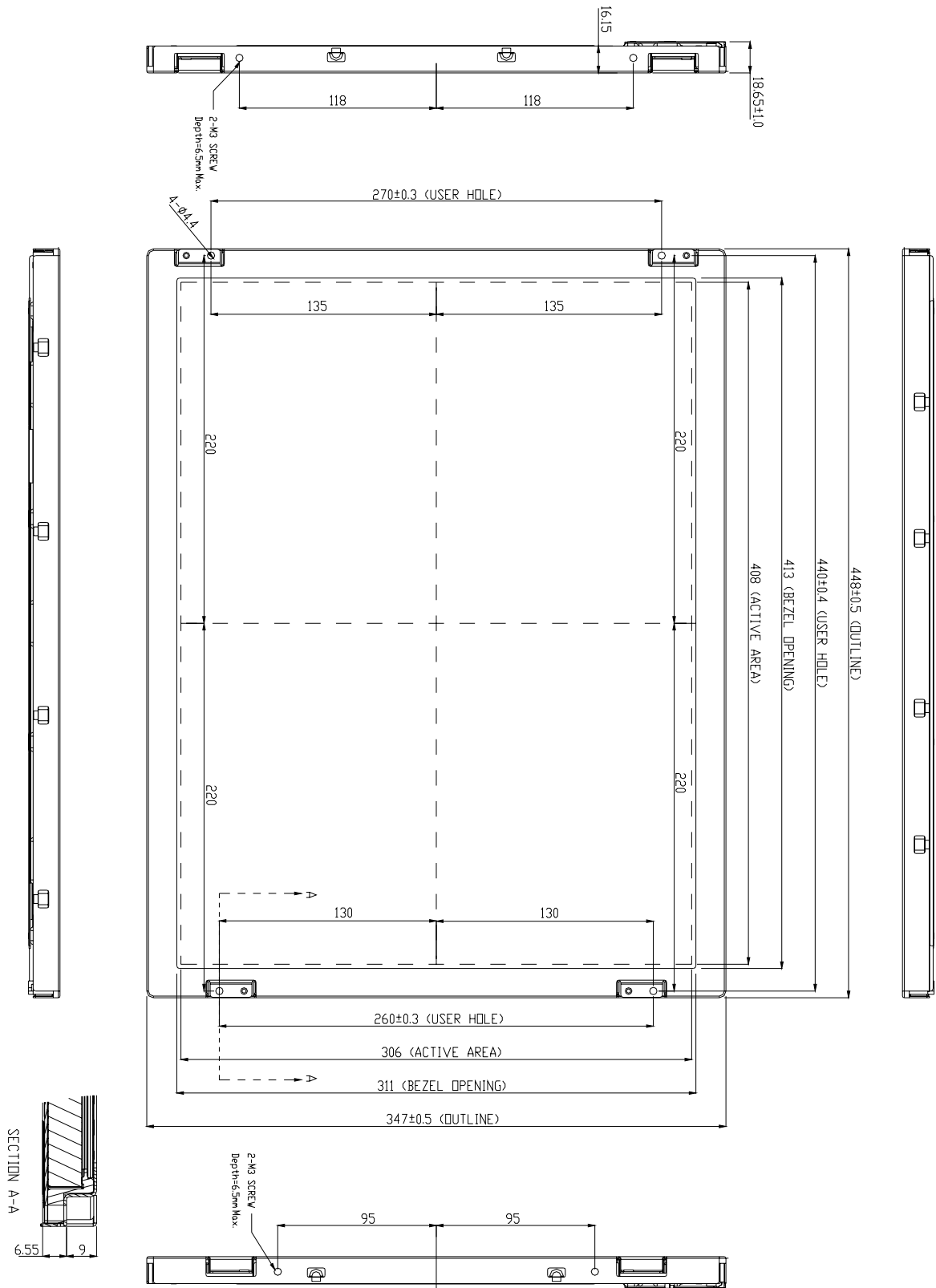

(b) Rear side (Tolerance is $\pm 0.5\text{mm}$ unless noted)

Unit: mm

The length of lamp wire(A) is $140\pm 15\text{mm}$.

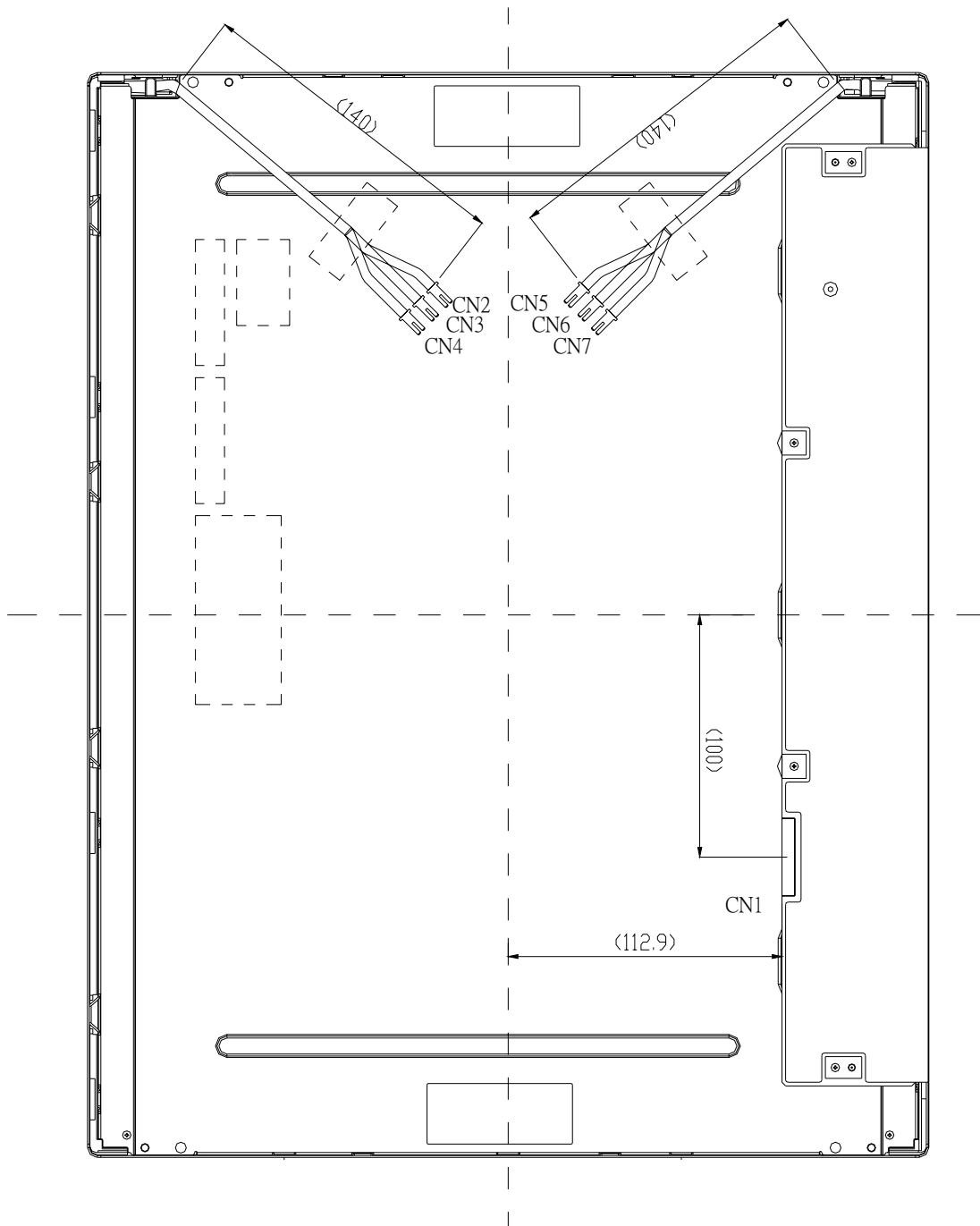

8.OPTICAL CHARACTERISTICS

Ta=25°C, VCC=5.0V

ITEM	SYMBOL	CONDITION	MIN.	TYP.	MAX.	UNIT	Notes	
Contrast Ratio	CR	$\theta = \phi = 0^\circ$	450	500	--	--		
Luminance Center	L	$\theta = \phi = 0^\circ$	380	450	--	cd/m ²		
5P Luminance	Average	L	340	400	--	cd/m ²		
	Uniformity	ΔL	80	-	--	%		
9P Luminance	Average	L	300	350	--	cd/m ²		
	Uniformity	ΔL	75	-	--	%		
Response Time	Tr	$\theta = \phi = 0^\circ$	--	4	6	ms		
	Tf	$\theta = \phi = 0^\circ$	--	8	10	ms		
Image sticking vanish time	Tis	2hours	--	--	2	sec		
Viewing Angle	Horizontal	ϕ	CR \geq 5	-80~80	-85~85	--	°	
	Vertical	θ		-80~80	-85~85	--	°	
	Horizontal	ϕ	CR \geq 10	(-75~75)	(-80~80)	--	°	
	Vertical	θ		(-60~65)	(-65~70)	--	°	
Color Coordinates	Red	x	$\theta = \phi = 0^\circ$	(0.619)	(0.649)	(0.679)	-	--
		y		(0.297)	(0.327)	(0.357)		
	Green	x		(0.246)	(0.276)	(0.306)		
		y		(0.583)	(0.613)	(0.643)		
	Blue	x		(0.114)	(0.144)	(0.174)		
		y		(0.047)	(0.077)	(0.107)		
	White	x		0.253	0.283	0.313		
		y		0.267	0.297	0.327		

- These items are measured by BM-5A (TOPCON) and EZ-Contrast in the dark room (no ambient light)
- Brightness condition : (IL=6.5 mA)
- Inverter: Frequency:55kHz
- Definition of these measurement items are as follows:

*1) Definition of Contrast Ratio

$$CR = \text{ON(White)Luminance} / \text{OFF(Black)Luminance}$$

*2) Central luminance: The white luminance is measured at the center position "5" on the screen, see Fig below.

5P Luminance (AVG): The white luminance is measured at measuring points 5 , 10 , 11 , 12 , 13 see Fig below.

9P Luminance (AVG): The white luminance is measured at measuring points 1 to 9, see Fig below.

$$\text{Uniformity : 5 point : } \Delta L = (L_{\text{MIN}} / L_{\text{MAX}}) \times 100\%$$

$$\text{Uniformity : 9 point : } \Delta L = (L_{\text{MIN}} / L_{\text{MAX}}) \times 100\%$$

CPT Confidential

W4408
Y3718

CLAA201VA07-tentative1-20051111

The information in this specification is tentative and may be changed with out prior notice. Please contact CPT before designing your product based on this specification

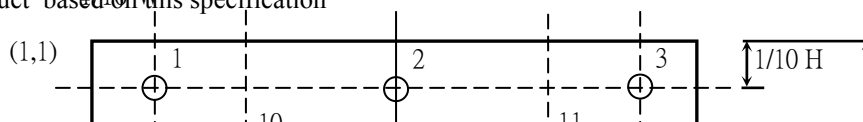

*3) Definition of Viewing Angle (θ, ϕ), measured by EZ-Contrast

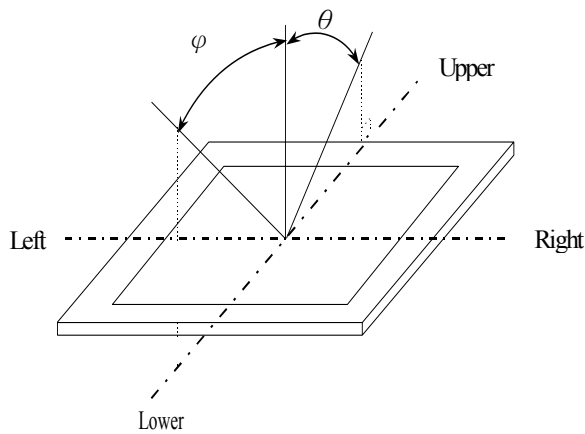

*4) Definition of Response Time (White - Black)

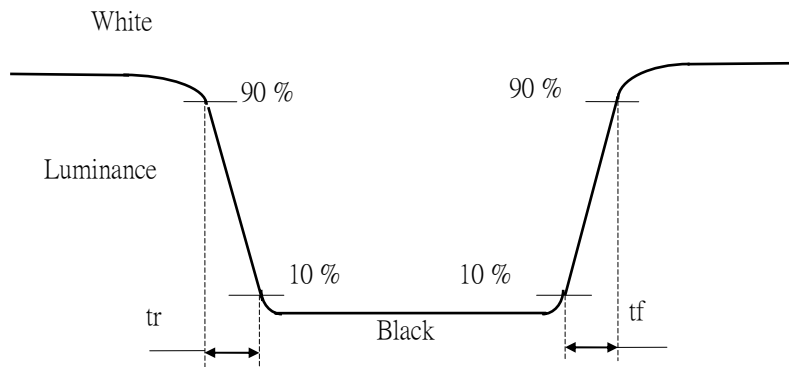

*5) Image sticking vanish time test method :

Around temperature condition : under 25°C ; Continuously display the test pattern as list for 2 hours , To change the module frame to full white pattern , It can not to be identified at this pattern as list in 2 seconds . it's displaying grade still under specification.

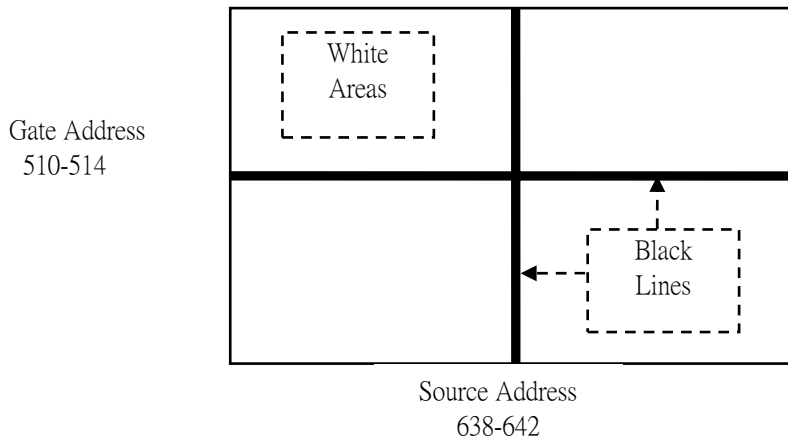

9.RELIABILITY TEST CONDITIONS

(1)Temperature and Humidity

TEST ITEMS	CONDITIONS
HIGH TEMPERATURE HIGH HUMIDITY OPERATION	40°C , 90%RH, 240h (No condensation)
HIGH TEMPERATURE HIGH HUMIDITY STORAGE	60°C,90% RH,48h (No condensation)
HIGH TEMPERATURE OPERATION	50°C , 240h
LOW TEMPERATURE STORAGE	-20°C , 240h
THERMAL SHOCK	BETWEEN -20°C (1hr)AND 60°C (1hr), 100 CYCLES
HIGH TEMPERATURE STORAGE	60°C , 240h
LOW TEMPERATURE OPERATION	0°C , 240h

(2)Shock & Vibration

ITEMS	CONDITIONS
SHOCK (NON- OPERATION)	Shock level: 1470m/s ² (150G) Waveform: half sinusoidal wave, 2ms Number of shocks: one shock input in each direction of three mutually perpendicular axes for a total of six shock inputs
VIBRATION (NON- OPERATION)	Vibration level: 9.8m/s ² (1.0G) zero to peak Waveform: sinusoidal Frequency range: 5 to 500 Hz Frequency sweep rate: 0.5 octave/min Duration: one sweep from 5 to 500 to 5 Hz in each of three mutually perpendicular axis(each x,y,z axis: 1 hour, total 3 hours)

(3)Judgment standard

The judgment of the above test should be made as follow:

Pass: Normal display image with no obvious non-uniformity and no line defect. Partial transformation of the module parts should be ignored.

Fail: No display image, obvious non-uniformity, or line defects.