



Chunghwa Picture Tubes, Ltd.

Technical Specification

To :

Date : 2011.03.28

CPT TFT-LCD
CLAB101NC05

ACCEPTED BY :
(TENTATIVE)

APPROVED BY	CHECKED BY	PREPARED BY
		Product Application Division

Niche Business Division
CHUNGHWA PICTURE TUBES, LTD.
1127 Hopin Rd., Padeh, Taoyuan, Taiwan 334, R.O.C.
TEL: +886-3-3675151 FAX: +886-3-377-3003

Doc. No:

CLAB100XB01-T1A

Issue Date:

2011/03/28

Table of Content

NO.	Table of Content	Page
1	OVERVIEW	4
2	ABSOLUTE MAXIMUM RATINGS	5
3	ELECTRICAL CHARACTERISTICS	6
4	CONNECTOR INTERFACE PIN & FUNCTION	9
5	INTERFACE TIMING CHART	10
6	BLOCK DIAGRAM	12
7	MECHANICAL SPECIFICATION	13
8	OPTICAL CHARACTERISTICS	14

1. OVERVIEW

CLAA101NC01 is 10.1" color TFT-LCD (Thin Film Transistor Liquid Crystal Display) module composed of LCD panel, LVDS driver ICs, control circuit. By applying 6 bit digital data, 1024×RGB (3) ×600, 262K-color images are displayed on the 10.1" diagonal screen. General specifications are summarized in the following table :

ITEM	SPECIFICATION
Display Area	222.72 (H)x125.28 (V) (10.1-inch diagonal)
Number of Pixels	1024 ×3(H)×600 (V)
Pixel Pitch	0.2175 (H)×0.2088(V)
Color Pixel Arrangement	RGB vertical stripe
Display Mode	Normally white
Number of Colors	262,144(6bits)(LVDS)
Optimum Viewing Angle	6 o'clock
Response Time	20ms (Typ)
Surface Treatment	Anti Glare , 3H
Viewing Angle	40° 、 40° /15° 、 30°(Min)

2. ABSOLUTE MAXIMUM RATINGS

The following are maximum value, which if exceeded, may cause faulty operation or damage to the unit.

ITEM	SYMBOL	MIN.	MAX.	UNIT	NOTE
LCD Power Voltage	VCC	0	4.0	V	
Operation Temperature	Top	0	50	°C	*1).*2).* 3).*4)
Storage Temperature	Tstg	-25	65	°C	*1).*2).*3)

【Note】

- *1) The relative temperature and humidity range are as below sketch, 90%RH Max. ($T_a \leq 40^\circ\text{C}$)
- *2) The maximum wet bulb temperature $\leq 39^\circ\text{C}$ ($T_a > 40^\circ\text{C}$) and without dewing.
- *3) If product in environment which over the definition of the relative temperature and humidity out of range too long, it will affect visual of LCD.
- *4) If you operate LCD in normal temperature range, the center surface of panel should be under 50°C .

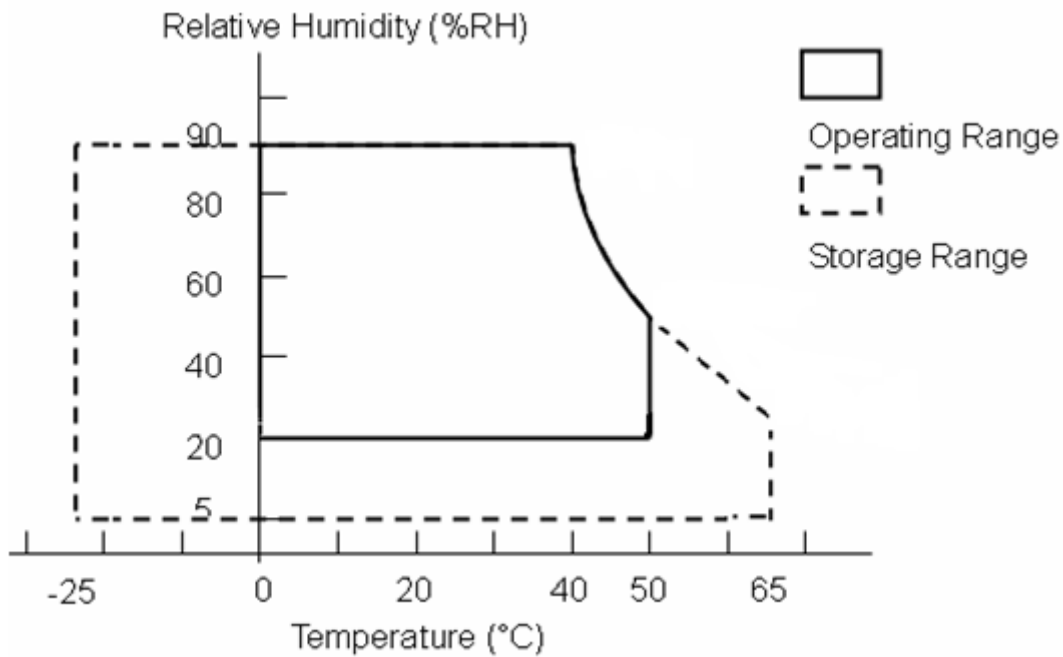

3. ELECTRICAL CHARACTERISTICS

(A) TFT LCD

ITEM		SYMBOL	MIN	TYP	MAX	UNIT	NOTE
LCD Power Voltage		VCC	3.0	3.3	3.6	V	*1)
LCD Power Current		ICC	(TBD)	(TBD)	(TBD)	mA	*2)
Rush Current		Irush	-	-	2	A	*4)
Logic Input Voltage (LVDS: IN+,IN-)	Common Voltage	VCM	VID /2		2.4 - (VID /2)	V	*3)
	Differential Input Voltage	VID	100	-	600	mV	*3)
	Threshold Voltage(HIGH)	VTH	-	-	100	mV	*3) VCM =1.2V
	Threshold Voltage(LOW)	VTL	-100	-	-	mV	

【Note】

*1) Power Sequence :

- $0.50 \text{ ms} \leq t1 \leq 10 \text{ ms}$
- $0.01 \text{ ms} < t2 \leq 50 \text{ ms}$
- $0.01 \text{ ms} < t3 \leq 50 \text{ ms}$
- $500 \text{ ms} \leq t4$
- $200 \text{ ms} \leq t5$
- $200 \text{ ms} \leq t6$

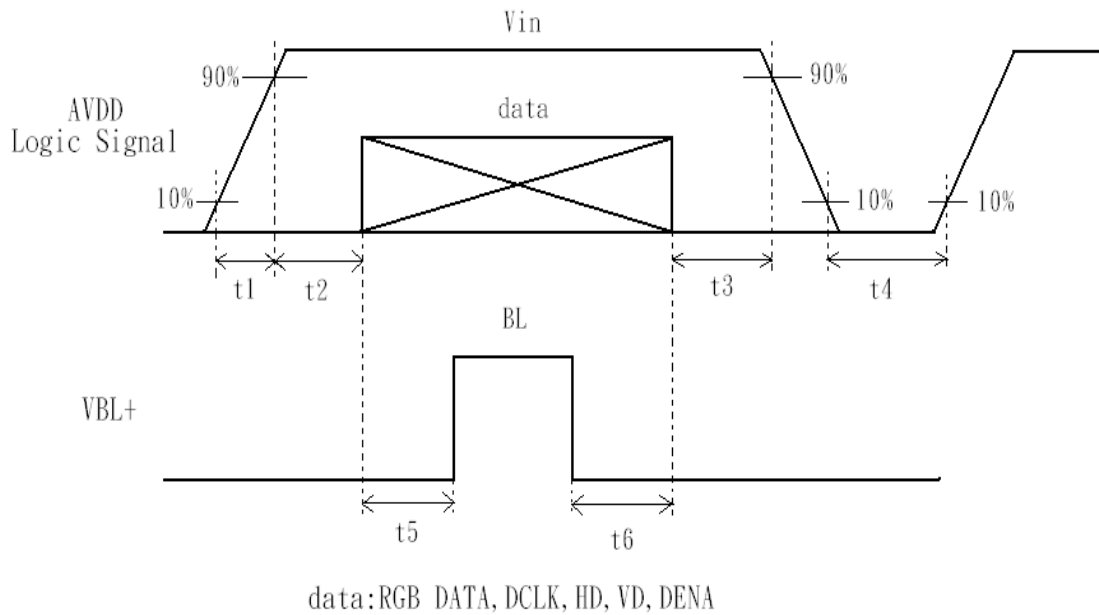

VCC-dip state

(1)when $3.0V > VCC \geq 2.7V$, $t_d \leq 10$ ms.

(2)when $VCC < 2.7V$, VCC-dip condition should as the VCC-turn-off condition.

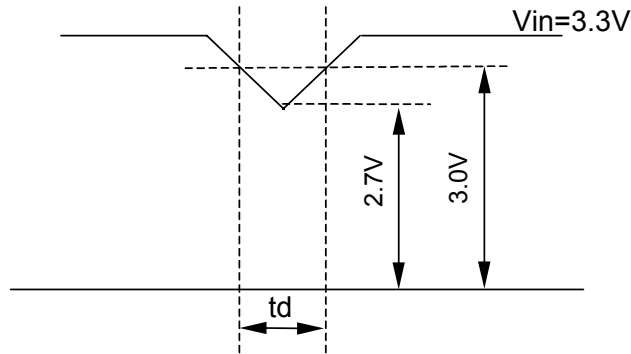

*2) Typical value is Mosaic (32*36 Checker board) Pattern : 768 line mode.

Circuit condition (Typ) : $VCC=3.3$ V , $f_V=60$ Hz , $f_H=48.35$ kHz , $f_{CLK}=58.03$ MHz.

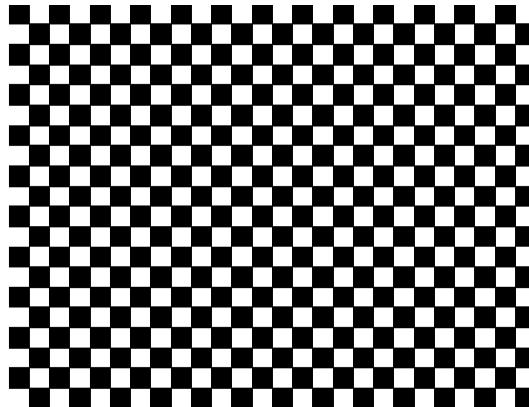

Max value is Black Pattern : 768 line mode.

Circuit condition (Max) : $VDD=3.3$ V , $f_V=60$ Hz , $f_H=48.35$ kHz , $f_{CLK}=58.03$ MHz.

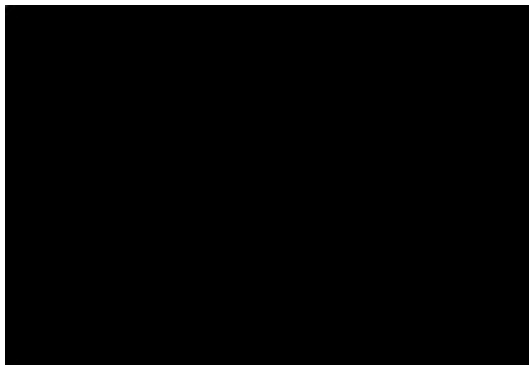

*3) LVDS Signal Definite :

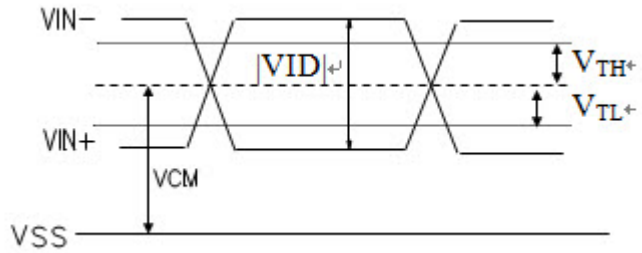
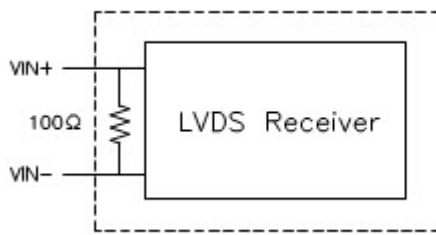

VIN+ : Positive differential DATA & CLK Input

VIN- : Negative differential DATA & CLK Input

*4) Irush measure condition

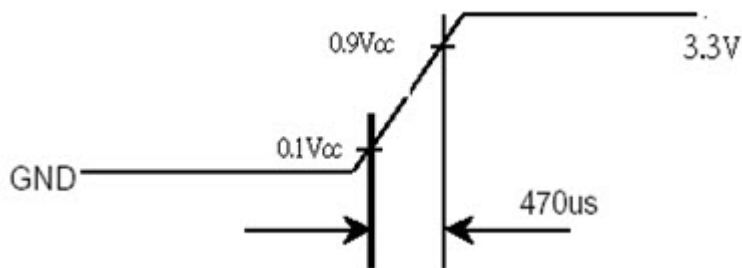
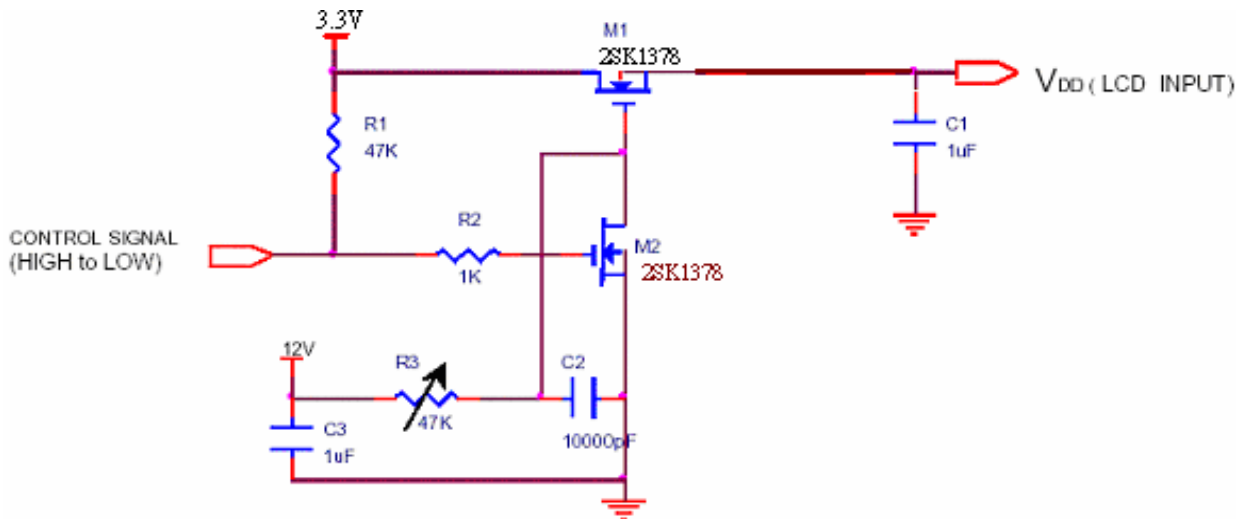

4. Connector Interface PIN & Function

CN (Interface signal)

Connector type : CN1(Input signal) 093F30-B0B01A or compatible

Pin No.	SYMBOL	FUNCTION
1	NC	NC
2	V _{CC}	+3.3V Power
3	V _{CC}	+3.3V Power
4	V_EDID	EDID 3.3V Power
5	NC	NC
6	CLK_EDID	EDID Clock
7	DATA_EDID	EDID Data
8	RXIN0-	LVDS Signal(-)—channel 0
9	RXIN0+	LVDS Signal(+)—channel 0
10	GND	Ground
11	RXIN1-	LVDS Signal(-)—channel 1
12	RXIN1+	LVDS Signal(+)—channel 1
13	GND	Ground
14	RXIN2-	LVDS Signal(-)—channel 2
15	RXIN2+	LVDS Signal(+)—channel 2
16	GND	Ground
17	RXCLKIN-	LVDS Clock Signal(-)
18	RXCLKIN+	LVDS Clock Signal(+)
19	GND	Ground
20	NC	NC
21	NC	NC
22	GND	Ground
23	NC	NC
24	NC	NC
25	GND	Ground
26	NC	NC
27	NC	NC
28	GND	Ground
29	NC	NC
30	NC	NC
31	(VSSLED)	(Ground – LED)
32	(VSSLED)	(Ground – LED)
33	(VSSLED)	(Ground – LED)
34	NC	NC
35	(PWM)	(System PWM Signal Input (+3.3V Swing))
36	(LED_EN)	(LED enable pin (+3.3V Input))
37	NC	NC(Please let it floating for CPT test only)
38	(V _{LED})	(Power Supply for LED(V _{LED} =5V ~ 19V))
39	(V _{LED})	(Power Supply for LED(V _{LED} =5V ~ 19V))
40	(V _{LED})	(Power Supply for LED(V _{LED} =5V ~ 19V))

5. INTERFACE TIMING CHART

(A) Timing Chart

ITEM		SYMBOL	MIN	TYP	MAX	UNIT		
LCD Timing	Frame Rate		-	(60)	60	(60)	Hz	
	DCLK	Frequency	f_{CLK}	42.59	45	61.51	MHz	
		Period	t_{CLK}	21.06	22.22	23.47	ns	
	DENA	Horizontal	Horizontal Total time	t_H	1160	1200	1620	t_{CLK}
			Horizontal Active time	t_{HA}	1024			
			Horizontal Blank time	t_{HB}	136	176	578	t_{CLK}
		Vertical	Vertical Total time	t_V	612	625	640	t_H
			Vertical Active time	t_{VA}	600			
			Vertical Blank time	t_{VB}	12	25	40	t_H

【Note】

- *1) DENA (DATA ENABLE) usually is positive.
- *2) During the whole blank period, DCLK should keep input.

(B) Time Sequence

(a.) Horizontal sequence

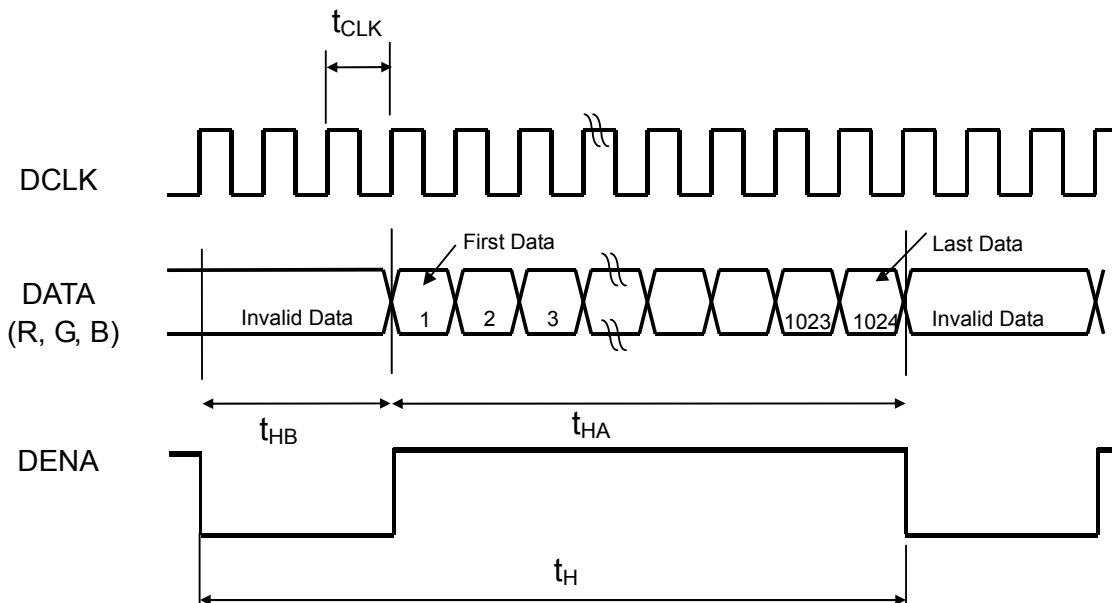

(b.) Vertical sequence

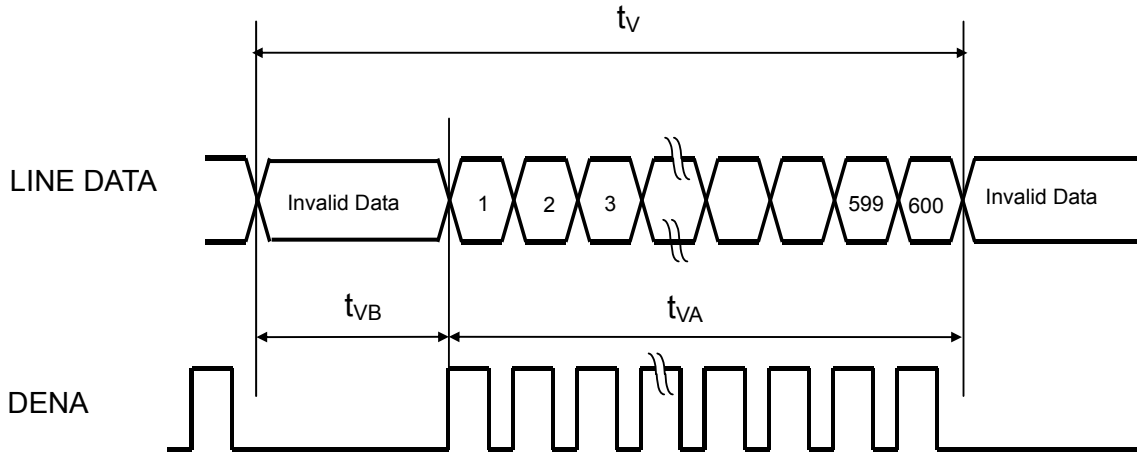

(3) DATA mapping

COLOR	INPUT DATA	R DATA						G DATA						B DATA					
		R5 MSB	R4	R3	R2	R1	R0 LSB	G5 MSB	G4	G3	G2	G1	G0 LSB	B5 MSB	B4	B3	B2	B1	B0 LSB
BASIC COLOR	BLACK	0	0	0	0	0	0	0	0	0	0	0	0	0	0	0	0	0	0
	RED(255)	1	1	1	1	1	1	0	0	0	0	0	0	0	0	0	0	0	0
	GREEN(255)	0	0	0	0	0	0	1	1	1	1	1	1	0	0	0	0	0	0
	BLUE(255)	0	0	0	0	0	0	0	0	0	0	0	0	1	1	1	1	1	1
	CYAN	0	0	0	0	0	0	1	1	1	1	1	1	1	1	1	1	1	1
	MAGENTA	1	1	1	1	1	1	0	0	0	0	0	0	1	1	1	1	1	1
	YELLOW	1	1	1	1	1	1	1	1	1	1	1	1	0	0	0	0	0	0
	WHITE	1	1	1	1	1	1	1	1	1	1	1	1	1	1	1	1	1	1
RED	RED(0)	0	0	0	0	0	0	0	0	0	0	0	0	0	0	0	0	0	0
	RED(1)	0	0	0	0	0	1	0	0	0	0	0	0	0	0	0	0	0	0
	RED(2)	0	0	0	0	1	0	0	0	0	0	0	0	0	0	0	0	0	0
	RED(254)	1	1	1	1	1	0	0	0	0	0	0	0	0	0	0	0	0	0
	RED(255)	1	1	1	1	1	1	0	0	0	0	0	0	0	0	0	0	0	0
GREEN	GREEN(0)	0	0	0	0	0	0	0	0	0	0	0	0	0	0	0	0	0	0
	GREEN(1)	0	0	0	0	0	0	0	0	0	0	0	1	0	0	0	0	0	0
	GREEN(2)	0	0	0	0	0	0	0	0	0	0	1	0	0	0	0	0	0	0
	GREEN(254)	0	0	0	0	0	0	1	1	1	1	1	0	0	0	0	0	0	0
	GREEN(255)	0	0	0	0	0	0	1	1	1	1	1	1	0	0	0	0	0	0
BLUE	BLUE(0)	0	0	0	0	0	0	0	0	0	0	0	0	0	0	0	0	0	0
	BLUE(1)	0	0	0	0	0	0	0	0	0	0	0	0	0	0	0	0	0	1
	BLUE(2)	0	0	0	0	0	0	0	0	0	0	0	0	0	0	0	0	1	0
	BLUE(254)	0	0	0	0	0	0	0	0	0	0	0	0	1	1	1	1	1	0
	BLUE(255)	0	0	0	0	0	0	0	0	0	0	0	0	1	1	1	1	1	1

【Note】

- 1) Gray level : Color(n) : n is level order; higher n means brighter level.
- 2) DATA : 1: high , 0: low

6. BLOCK DIAGRAM

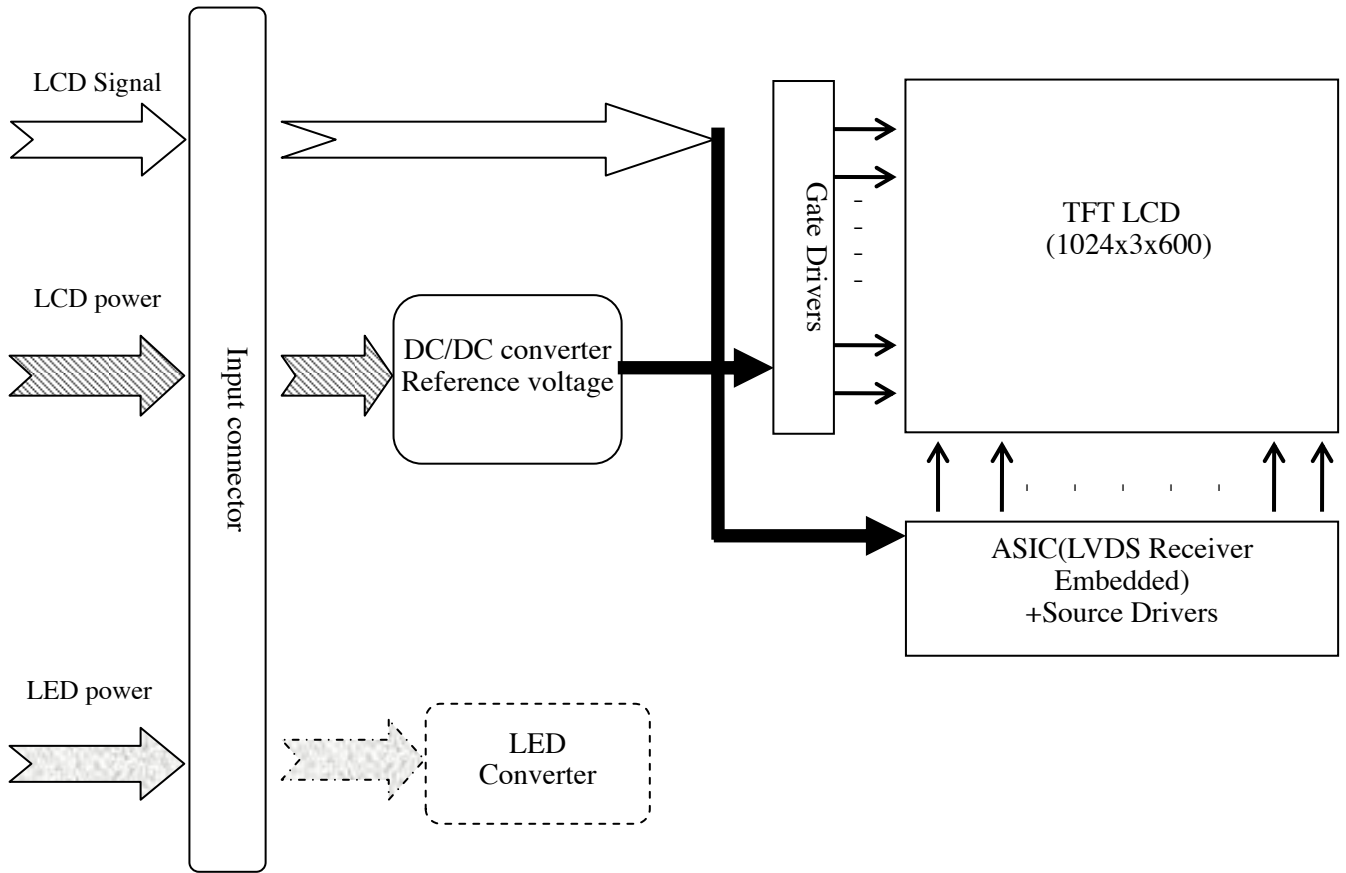

7. MECHANICAL SPECIFICATION

The tolerance, not show in the figure, is ± 0.5 mm.

[Unit : mm]

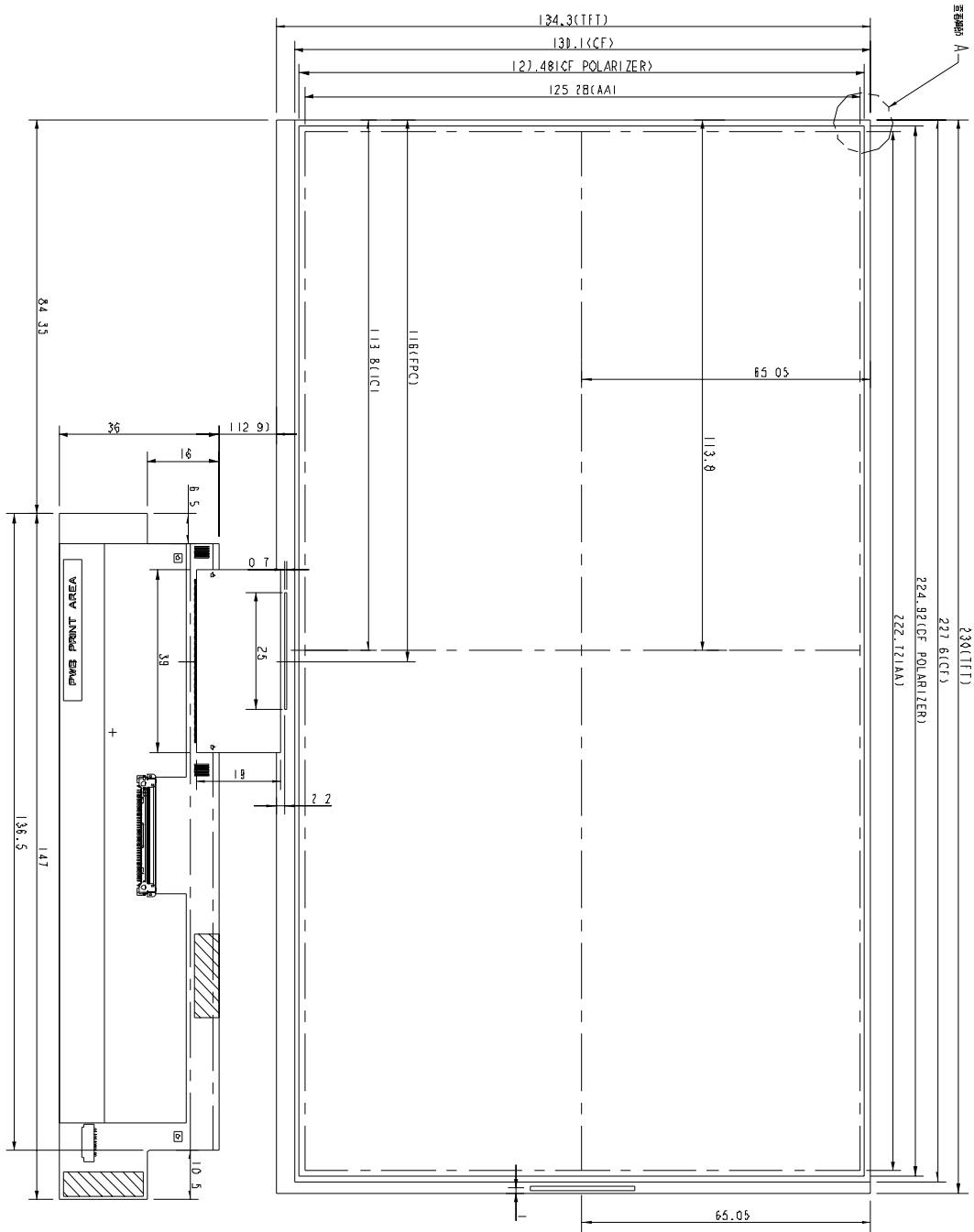

8. OPTICAL CHARACTERISTICS

Ta=25°C , VDD=3.3V

ITEM		SYMBOL	CONDITION	MIN	TYP	MAX	UNIT	NOTE
Contrast Ratio (CEN)		CR	$\theta = \psi = 0^\circ$	(400)	(500)	--	--	*1) 2)
Transmittance (CEN)		T%	$\theta = \psi = 0^\circ$	(4.8)	(5.3)	--	%	*1) 5)
Response Time		Tr	$\theta = \psi = 0^\circ$	--	20	--	ms	*4)
		Tf						
View Angle	Horizontal	ψ	$CR \geq 10$	40/-40	--	--	°	*3)
	Vertical	θ		15/-30	--	--	°	*3)
Color Coordinate	W	x	$\theta = \psi = 0^\circ$ (CPTBLU)	0.283	0.313	0.343		*2)
		y		0.299	0.329	0.359		
	R	x		TBD	TBD	TBD		
		y		TBD	TBD	TBD		
	G	x		TBD	TBD	TBD		
		y		TBD	TBD	TBD		
	B	x		TBD	TBD	TBD		
y		TBD	TBD	TBD				

Color coordinate and color gamut are measured by SRUL1R, response time is measured by TRD-100, and all the other items are measured by BM-5A (TOPCON). All these items are measured under the dark room condition (no ambient light).

Measurement Condition: IL= 20mA (each LED)

Definition of these measurement items is as follows:

*1) Setup of Measurement Equipment

The LCD module should be turn-on to a stable luminance level to be reached. The measurement should be executed after lighting Backlight for 20 minutes and in a dark room.

*2) Definition of Contrast Ratio

CR=ON (White) Luminance/OFF (Black) Luminance

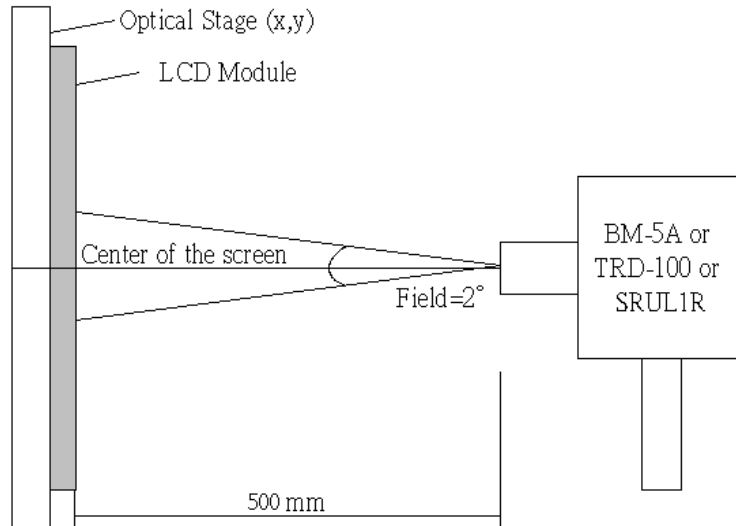

***3) Definition of view angle(θ , ψ)**

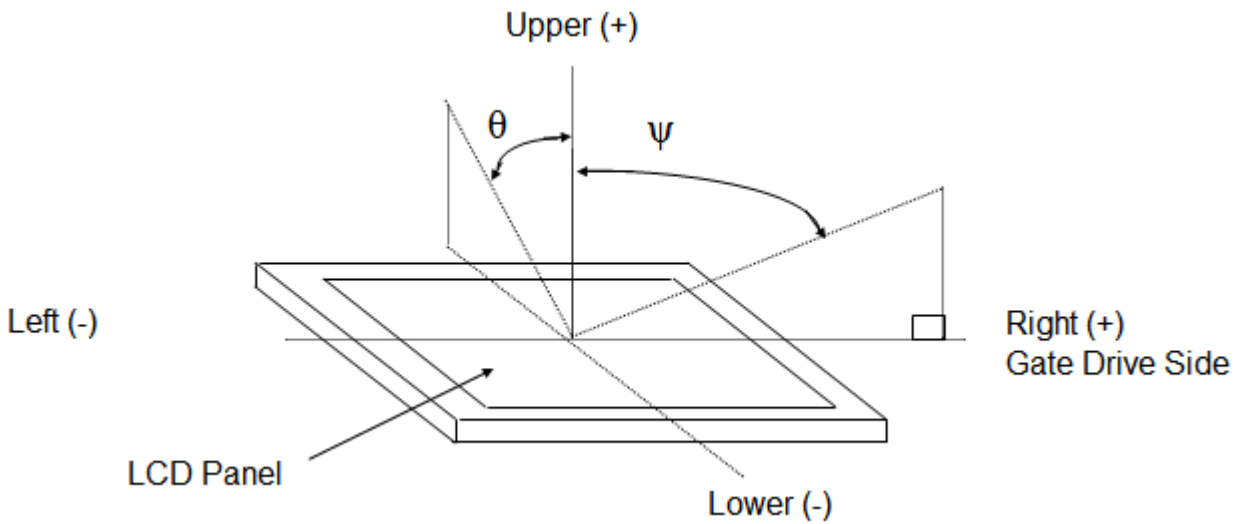

***4) Definition of response time**

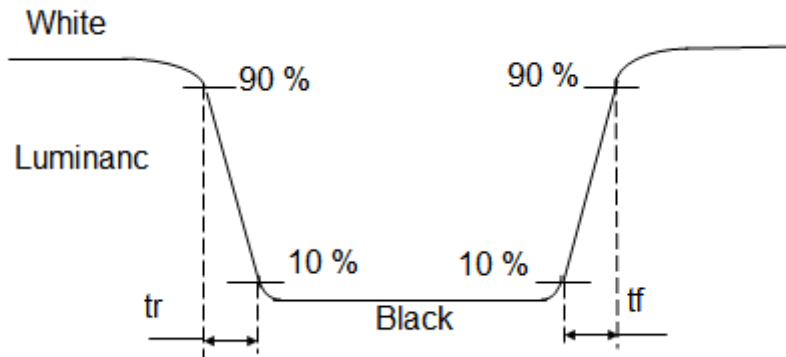

***5) Definition of Transmittance (T%)**

Transmittance=(Luminance of LCD module/Luminance of backlight)* 100%