

Version: 1.0

TECHNICAL SPECIFICATION

MODEL NO: ED060SD1

The content of this information is subject to be changed without notice.
Please contact E Ink or its agent for further information.

Customer's Confirmation

Customer _____

Date _____

By _____

E Ink's Confirmation

Revision History

Rev.	Issued Date	Revised	Contents
1.0	Dec,20, 2015	Formal	

Eink Confidential

TECHNICAL SPECIFICATION

CONTENTS

<i>NO.</i>	<i>ITEM</i>	<i>PAGE</i>
-	Cover	1
-	Revision History	2
-	Contents	3
1	General Description	4
2	Features	4
3	Mechanical Specifications	4
4	Mechanical Drawing of EPD module	5
5	Input/Output Terminals	6
6	Touch Panel Characteristic	8
7	Electrical Characteristics	10
8	Power Sequence	15
9	Optical Characteristics	17
10	Handling, Safety and Environment Requirements And Remark	18
11	Reliability test	20
12	Border definition	21
13	Block Diagram	22

1. General Description

ED060SD1 is a reflective electrophoretic E Ink® technology display module based on active matrix TFT substrate featuring capacitive touch panel. It has 6” active area with 600 x 800 pixels, the display is capable to display images at 2-16 gray levels (1-4 bits) depending on the display controller and the associated waveform file it used.

2. Features

- Carta High contrast reflective/electrophoretic technology
- 600 x 800 display
- High reflectance
- Ultra wide viewing angle
- Ultra low power consumption
- Pure reflective mode
- Bi-stable
- Commercial temperature range
- Landscape, portrait mode
- Capacitive touch with film type

3. Mechanical Specifications

Parameter	Specifications	Unit	Remark
Screen Size	6.0 (3:4 diagonal)	Inch	
Display Resolution	600 (H)×800(V)	Pixel	
Active Area	90.6 (H)×122.4 (V)	mm	
Pixel Pitch	0.151 (H)×0.153 (V)	mm	
Pixel Configuration	Rectangle		
Outline Dimension	101.8(W)×138.4(H)×1.31(D) (panel area height)	mm	
Module Weight	33.05±3.5	g	
Number of Gray	16 Gray Level (monochrome)		
Display operating mode	Reflective mode		

4. Mechanical Drawing of EPD Module

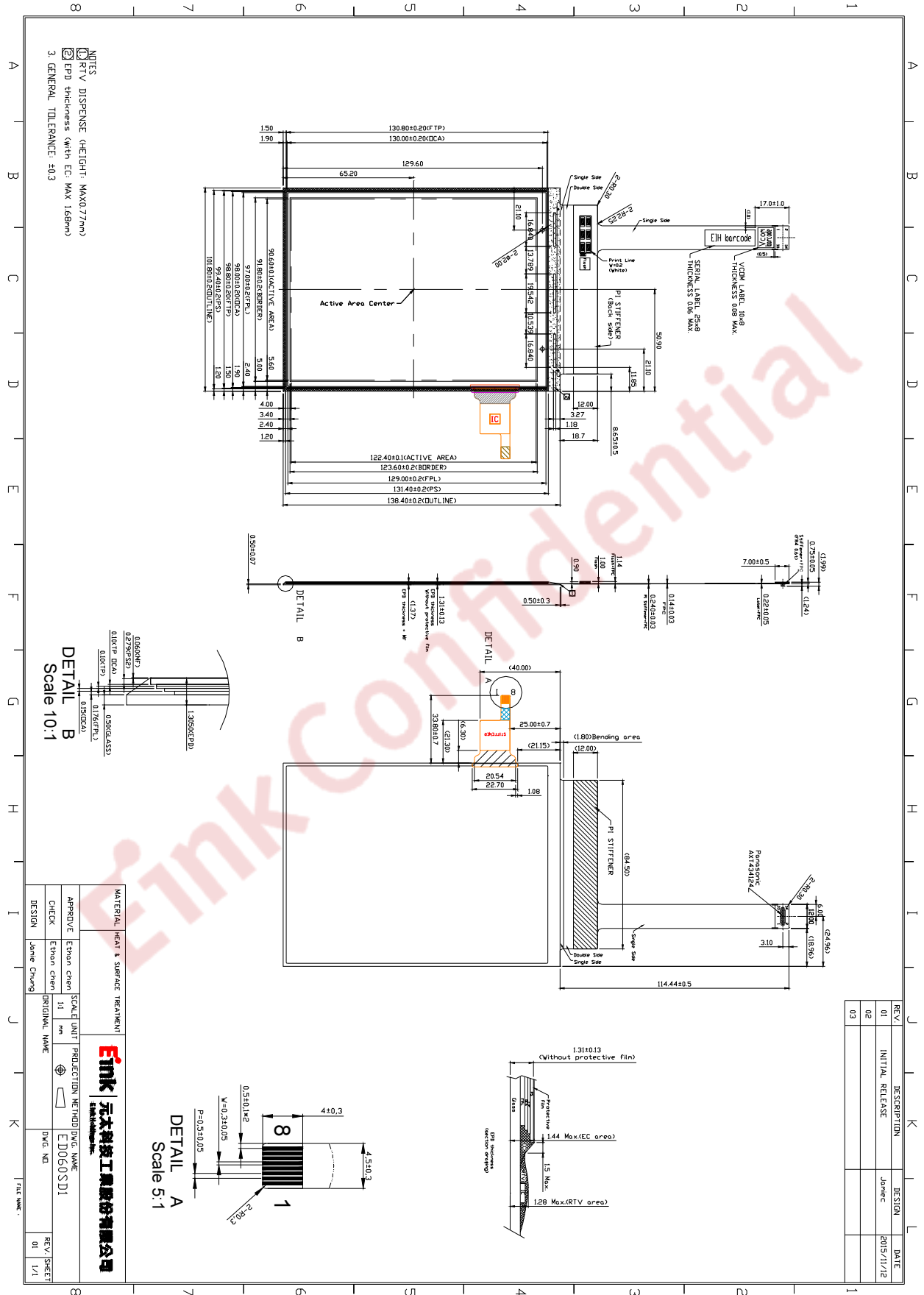

5. Input/Output Interface

5-1) Connector type: AXT434124

Pin Assignment

Pin #	Signal	Description	Remark
1	VNEG	Negative power supply source driver	
2	VPOS	Positive power supply source driver	
3	VNEG	Negative power supply source driver	
4	VPOS	Positive power supply source driver	
5	VDD	Digital power supply drivers	
6	VSS	Ground	
7	VDD	Digital power supply drivers	
8	VSS	Ground	
9	XCL	Clock source driver	
10	XLE	Latch enable source driver	
11	XOE	Output enable source driver	
12	XSTL	Start pulse source driver	
13	D0	Data signal source driver	
14	D1	Data signal source driver	
15	D2	Data signal source driver	
16	D3	Data signal source driver	
17	D4	Data signal source driver	
18	D5	Data signal source driver	
19	D6	Data signal source driver	
20	D7	Data signal source driver	
21	VCOM	Common connection	
22	NC	NC	
23	VCOM	Common connection	
24	NC	NC	
25	VGG	Positive power supply gate driver	
26	MODE1	Output mode selection gate driver	
27	VEE	Negative power supply gate driver	
28	CKV	Clock gate driver	
29	VEE	Negative power supply gate driver	
30	SPV	Start pulse gate driver	
31	NC	NC	
32	BORDER	Border connection	
33	NC	NC	
34	NC	NC	

5-2) Scanning Direction

The following figure is seen from a front view. Also the arrow shows the direction of scan.

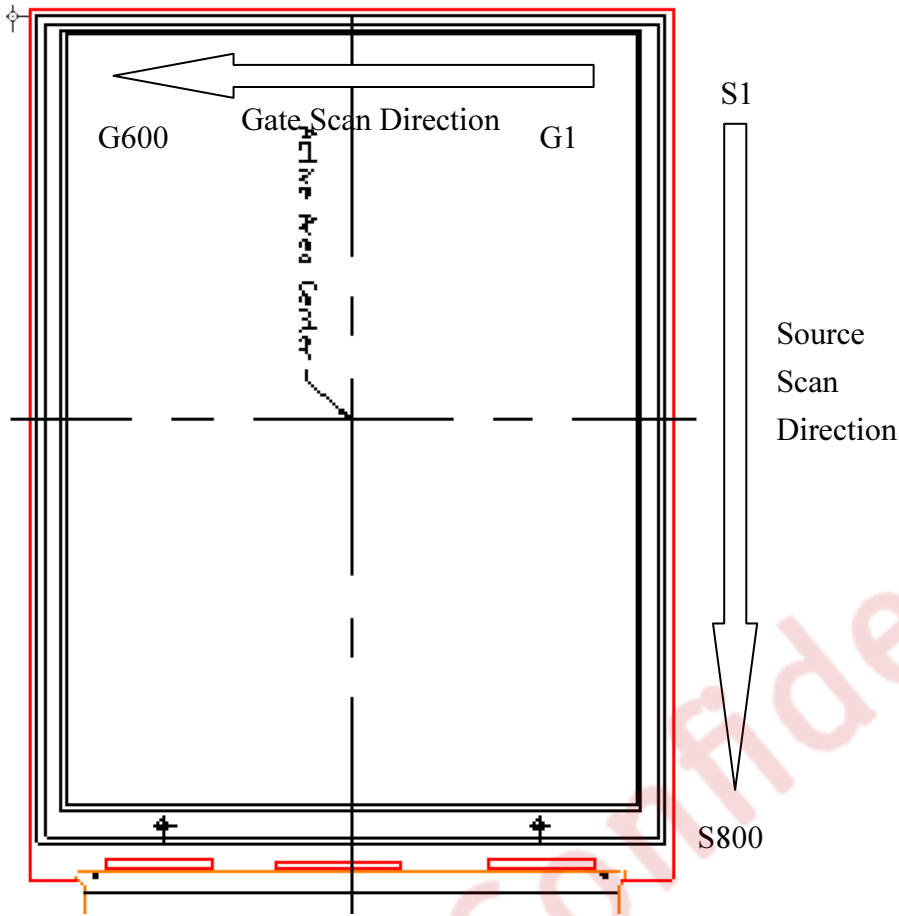

Eink Confidential

6. Touch Panel Characteristic

6-1) Electric Characteristic

Item	Spec.	
Chipset	EKT2232ALW (QFN48)	
Pin Assignment	Pin N	Assignment
	1	DGND
	2	VDD
	3	Reset
	4	INT
	5	SDA
	6	SCL
	7	NC
	8	NC
Supply Voltage	VDD:2.8V- 3.6V	
Power Consumption	Active(Single touch)power consumption 5mA(3.3V); Idle power consumption 2.5mA(3.3V); Sleep power consumption 20μ A(3.3V)	
Oscillator Frequency	10 MHz	
Interface	I2C	
Support OS	Android	
Support Points	1+G	
Resolution	1280 X 832	
Max. Report Rate	100Hz	

Touch function : 1 point + gesture

Symbol		Specification	Remark
Sensitivity		8mm	
Linearity	Center	+/-2mm	No display refresh
	Border	+/-4mm	
Accuracy	Center	+/-2mm	No display refresh
	Border	+/-4mm	
Jitter	Center	+/-2mm	No display refresh
	Border	+/-4mm	

Reporting rate : 85Hz

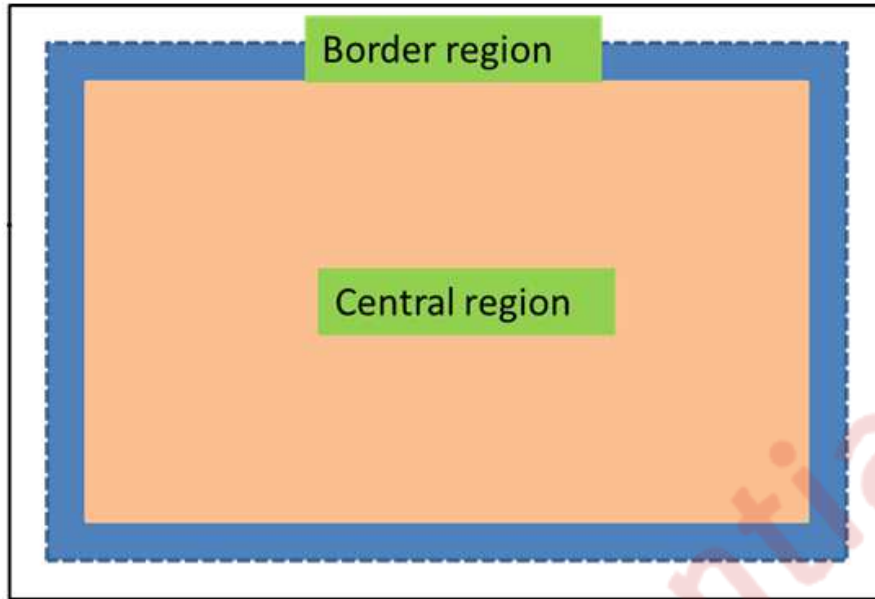

6.2) Absolute Maximum Rating

Items	Unit	Specifications	
		Top-axis	Bot-axis
Isolation Between Bars	MΩ	>20MΩ	
Wire resistance(the longest wire)	KΩ	1.12	1.03
Mesh resistance	KΩ	4.32	5.47
Non-conductance	/	No conduction	No conduction

7. Electrical Characteristics

7-1) Absolute maximum rating

Parameter	Symbol	Rating	Unit	Remark
Logic Supply Voltage	VDD	-0.3 to +7	V	--
Positive Supply Voltage	V _{POS}	-0.3 to +18	V	--
Negative Supply Voltage	V _{NEG}	+0.3 to -18	V	--
Max .Drive Voltage Range	V _{POS} - V _{NEG}	36	V	--
Supply Voltage	VGG	-0.3 to +45	V	--
Supply Voltage	VEE	-25.0 to +0.3	V	--
Supply Range	VGG-VEE	-0.3 to +45	V	--
Operating Temp. Range	TOTR	0 to +50	°C	--
Storage Temperature	TSTG	-25 to +70	°C	--

Eink Confidential

7-2) Panel DC characteristics

Parameter	Symbol	Conditions	Min	Typ	Max	Unit
Signal ground	V _{SS}		-	0	-	V
Logic Voltage supply	V _{DD}		3.0	3.3	3.6	V
	I _{VDD}	V _{DD} =3.3V	-	1.05	3.15	mA
Gate Negative supply	V _{EE}		-21	-20	-19	V
	I _{EE}	V _{EE} = -20V	-	0.8	2.4	mA
Gate Positive supply	V _{GG}		21	22	23	V
	I _{GG}	V _{GG} = 22V	-	0.8	2.4	mA
Source Negative supply	V _{NEG}		-15.4	-15	-14.6	V
	I _{NEG}	V _{NEG} = -15V	-	18	36	mA
Source Positive supply	V _{POS}		14.6	15	15.4	V
	I _{POS}	V _{POS} = 15V	-	16	32	mA
Border supply	V _{COM}		-2.5	Adjusted	-0.3	v
Asymmetry source	V _{Asym}	V _{POS} +V _{NEG}	-800	0	800	mV
Common voltage	V _{COM}		-2.5	Adjusted	-0.3	V
	I _{COM}		-	0.25	-	mA
Panel Power	P		-	547	1131	mW
Standby power panel	P _{STBY}		-	-	0.4	mW
Operating temperature			0	-	50	°C
Storage temperature			-25	-	70	°C

- The maximum power consumption is measured using 85Hz waveform with following pattern transition: from pattern of repeated 1 consecutive black scan lines followed by 1 consecutive white scan line to that of repeated 1 consecutive white scan lines followed by 1 consecutive black scan lines. (Note 7-1)
- The Typical power consumption is measured using 85Hz waveform with following pattern transition: from horizontal 4 gray scale pattern to vertical 4 gray scale pattern. (Note 7-2)
- The standby power is the consumed power when the panel controller is in standby mode.
- The listed electrical/optical characteristics are only guaranteed under the controller & waveform provided by E Ink.
- Vcom is recommended to be set in the range of assigned value $\pm 0.1V$.
- The maximum I_{COM} inrush current is about 800 mA

Note 7-1

The maximum power consumption

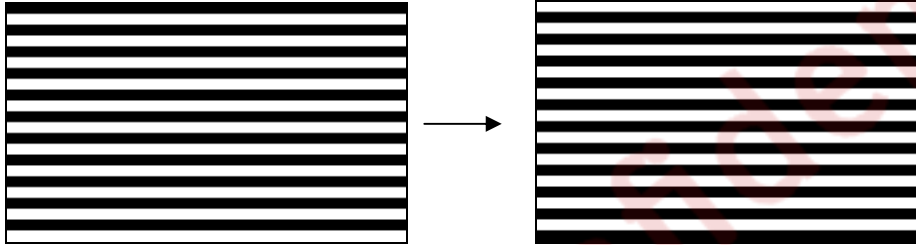

Note 7-2

The Typical power consumption

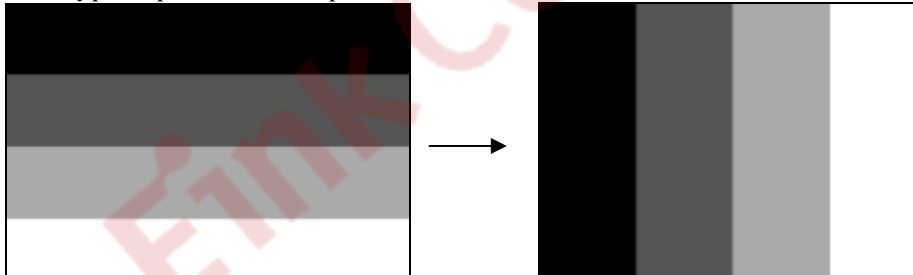

7-3) Refresh Rate

The module ED060SD1 is applied at a maximum screen refresh rate of 85Hz.

	Min	Max
Refresh Rate	-	85Hz

7-4) Display Module AC characteristics

VDD=3.0V to 3.6V, unless otherwise specified.

Parameter	Symbol	Min.	Typ.	Max.	Unit
Clock frequency	fckv	-	-	200	kHz
Minimum “L” clock pulse width	twL	0.5	-	-	us
Minimum “H” clock pulse width	twH	0.5	-	-	us
Clock rise time	trckv	-	-	100	ns
Clock fall time	tfckv	-	-	100	ns
SPV setup time	tSU	100	-	twH-100	ns
SPV hold time	tH	100	-	twH-100	ns
Pulse rise time	trspv	-	-	100	ns
Pulse fall time	tfspv	-	-	100	ns
Clock XCL cycle time	tcy	16.67	50	-	ns
D0 .. D7 setup time	tsu	8	-	-	ns
D0 .. D7 hold time	th	8	-	-	ns
XSTL setup time	tstls	0.5*tcy	-	0.8*tcy	ns
XSTL hold time	tstlh	0.5*tcy	-	240*tcy-tstls	ns
XLE on delay time	tLEdly	3.5*tcy	-	-	ns
XLE high-level pulse width (When VCC=3.0V to 3.6V)	tLEw	300	-	-	ns
XLE off delay time	tLEoff	200	-	-	ns
Output setting time to +/- 30mV(C _{load} =200pF)	tout	-	-	20	us

OUTPUT LATCH CONTROL SIGNALS

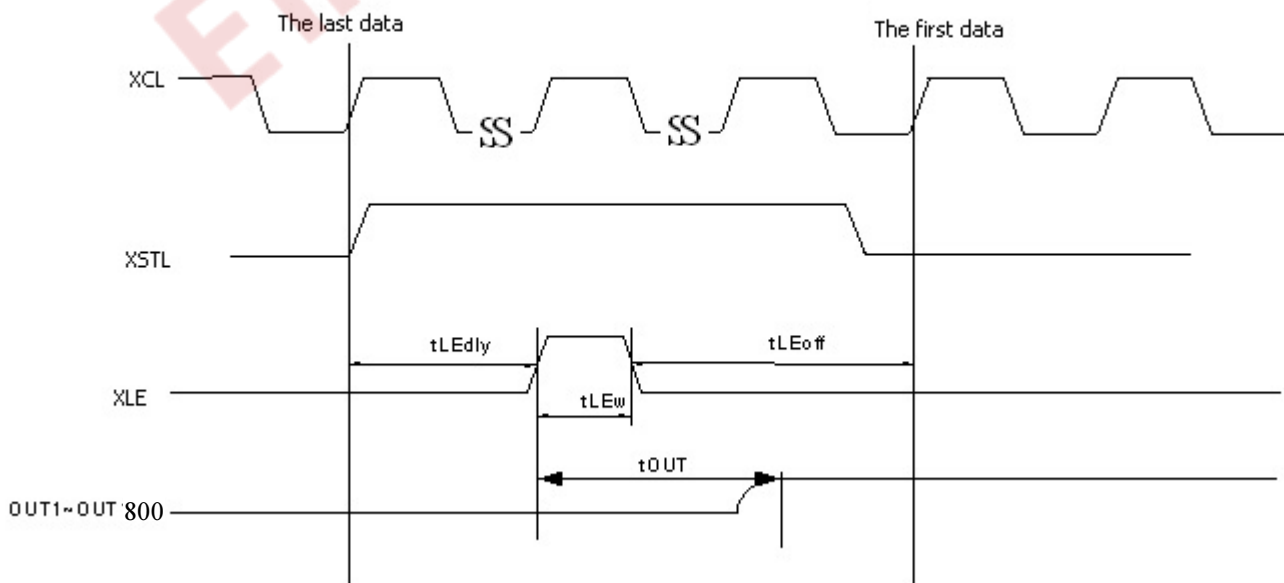

CLOCK & DATA TIMING

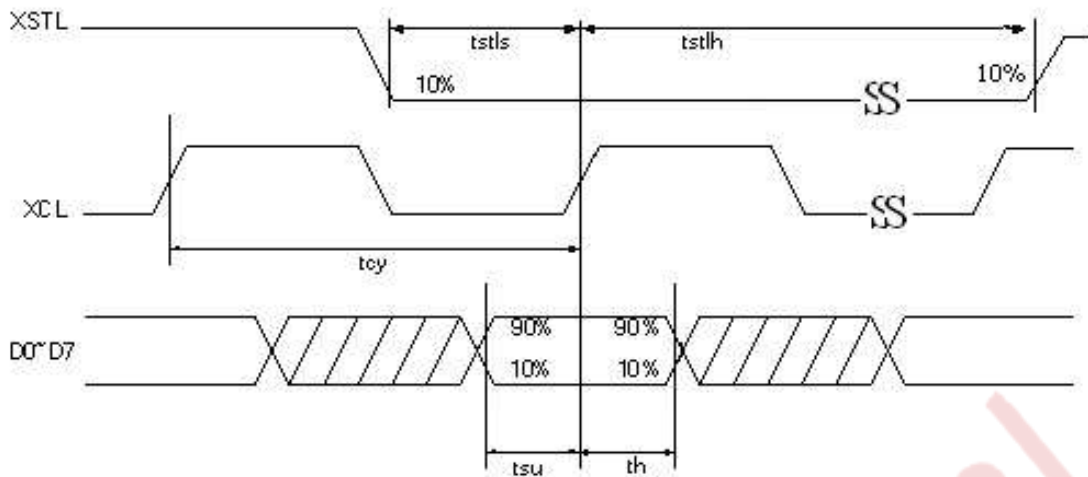

CKV & SPV TIMING

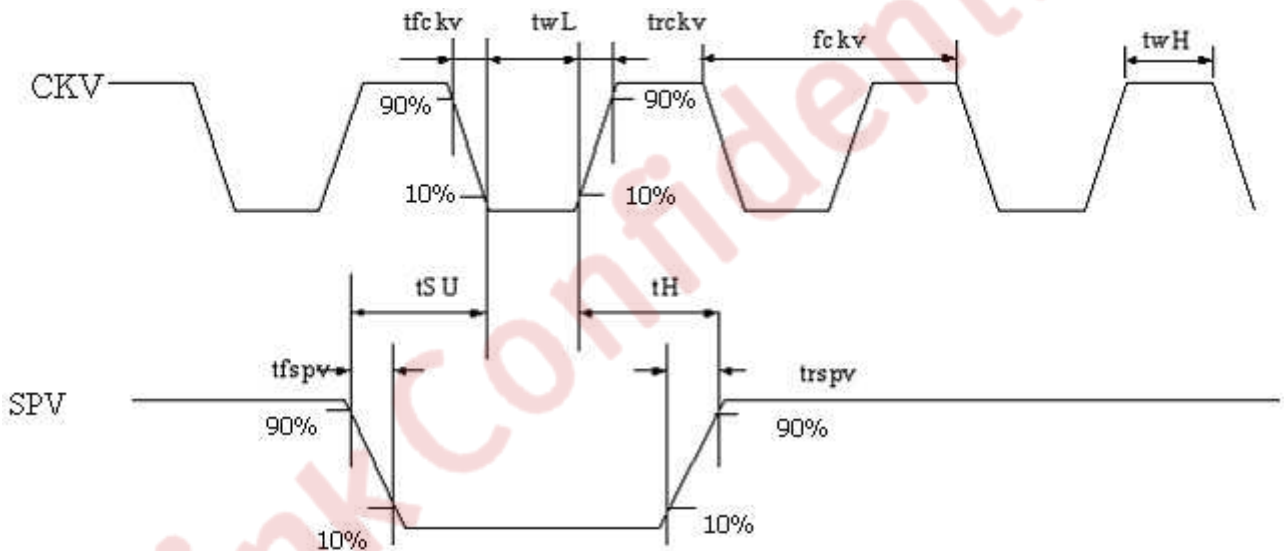

GATE OUTPUT TIMING

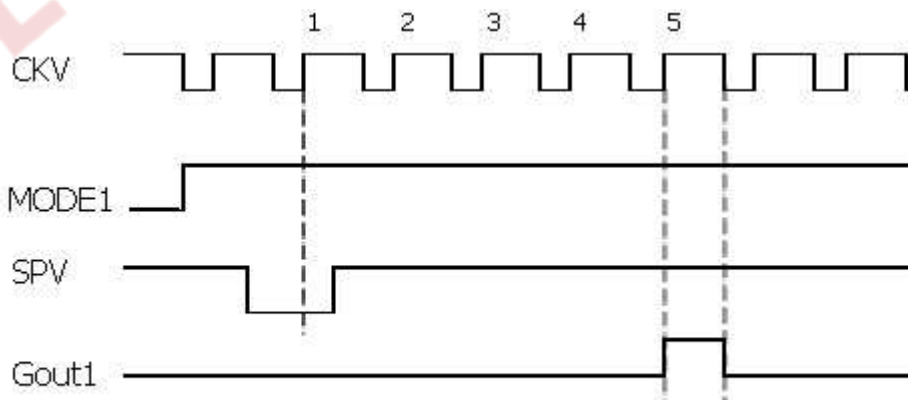

Note : First gate line on timing
After 5 CKV , gate line is on .

8. Power Sequence

Power Rail must be sequenced in the following order :

1. VSS → VDD → VNEG → VPOS (Source driver) → VCOM
2. VSS → VDD → VGL → VGH (Gate driver)

POWER ON

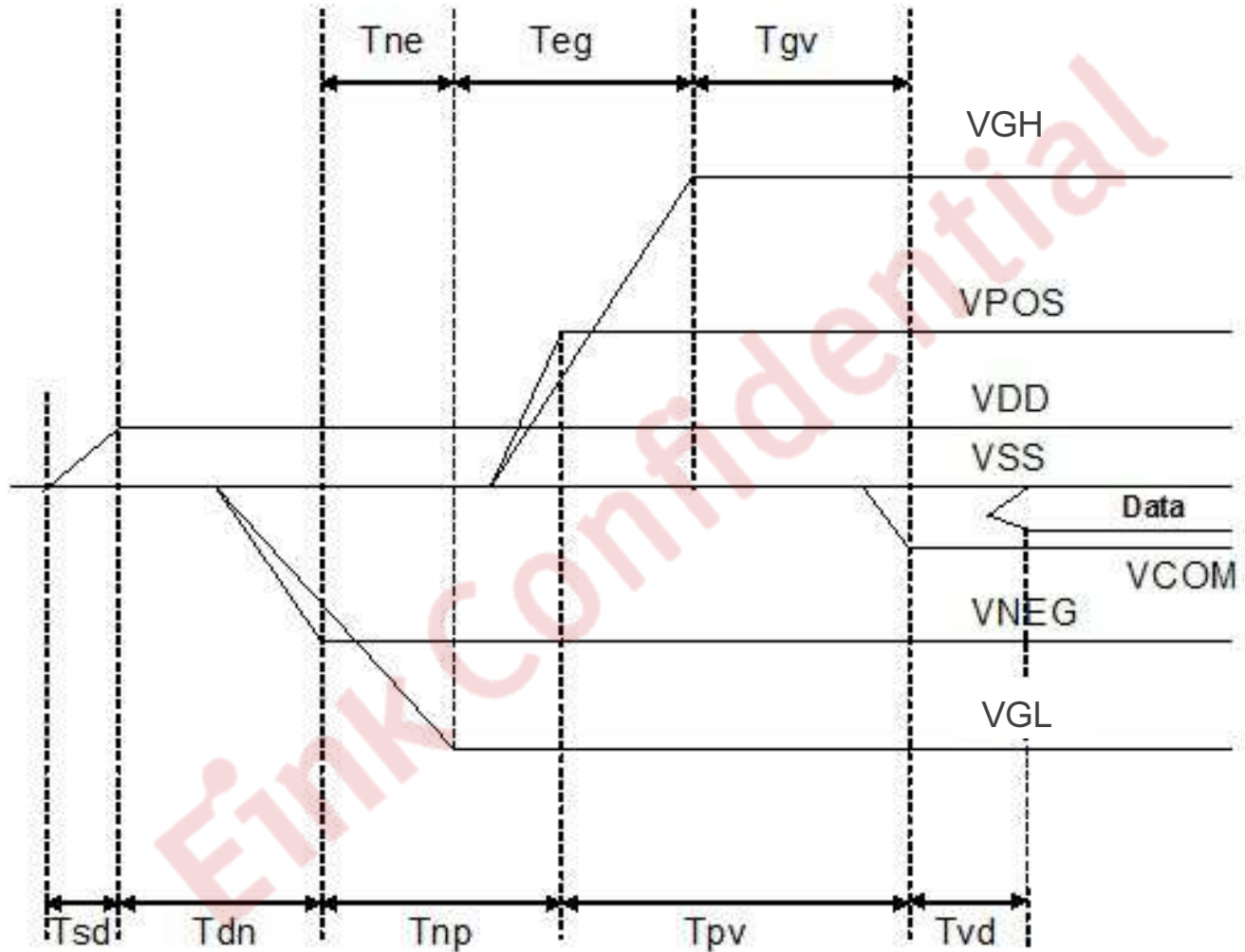

	Min	Max
T_{sd}	30us	-
T_{dn}	100us	-
T_{np}	1000us	-
T_{pv}	100us	-
T_{vd}	100us	-
T_{ne}	0us	-
T_{eg}	1000us	-
T_{gv}	100us	-

POWER OFF

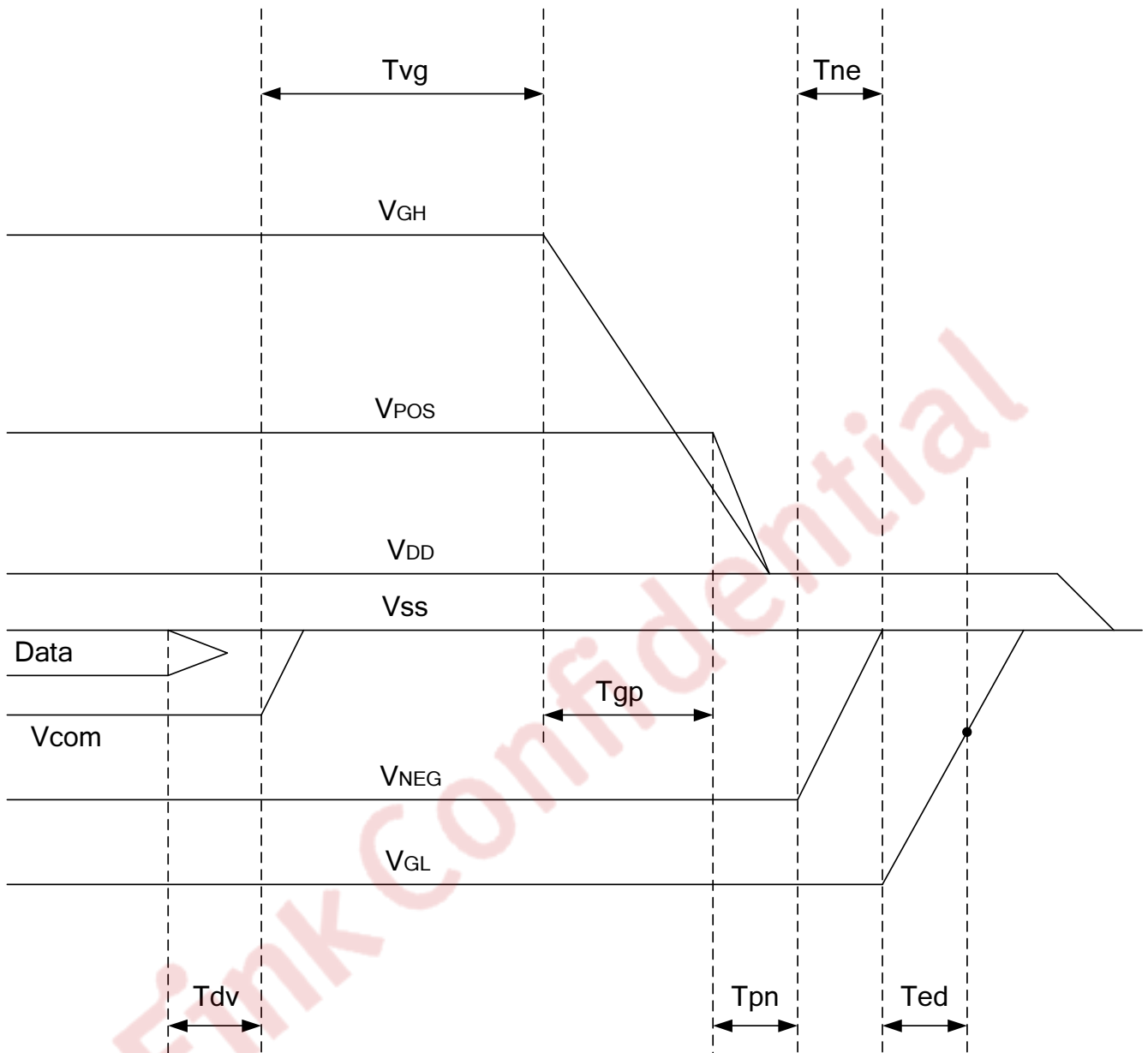

	Min	Max
Tdv	100 μ s	-
Tvg	0 μ s	-
Tgp	0 μ s	-
Tpn	0 μ s	-
Tne	0 μ s	-
Ted	0.5s	Discharged point @ -7.4 Volt

Note1 : Supply voltages decay through pull-down resistors.

Note2 : Begin to turn off VGL power after VNEG and VPOS are completely or almost discharged to VSS state.

Note3 : VGL must remain negative of Vcom during decay period

9. Optical characteristics

9-1) Specifications

Measurements are made by PR655 with MS-75 or equivalent SpectraScan Colorimeter with that the illumination is at an angle 45° from the perpendicular at the center of sample surface, and the detector is perpendicular unless otherwise specified.

T = 25°C

Symbol	Parameter	Conditions	Min	Typ.	Max	Unit	Note
R	Reflectance	White	37	45	-	%	-
Gn	N th Grey Level	-	-	DS+(WS-DS) ×n/(m-1)	-	L*	-
CR	Contrast Ratio	-	12	17	-	-	-

WS: White state , DS: Dark state, Gray state from Dark to White :DS、G1、G2...、Gn...、Gm-2、WS
m:4、8、16 when 2、3、4 bits mode

9-2) Definition of contrast ratio

The contrast ratio (CR) is the ratio between the reflectance in a full white area (RI) and the reflectance in a dark area (Rd): CR = RI / Rd

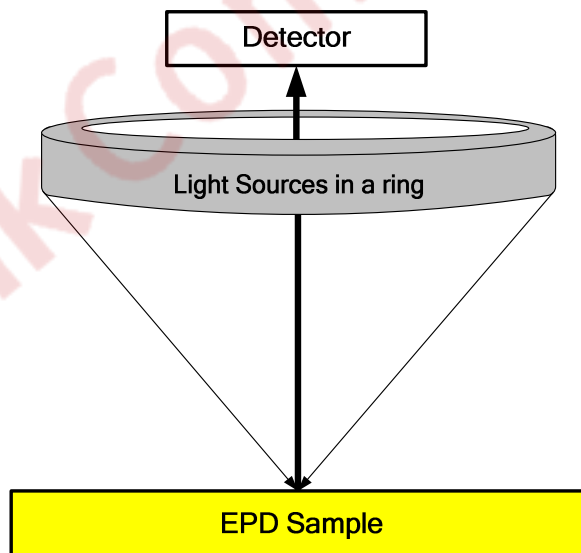

9-3) Reflection Ratio

The reflection ratio is expressed as:

$$R = \text{Reflectance Factor}_{\text{white board}} \times (L_{\text{center}} / L_{\text{white board}})$$

L_{center} is the luminance measured at center in a white area (R=G=B=1). $L_{\text{white board}}$ is the luminance of a standard white board.

10. HANDLING, SAFETY AND ENVIROMENTAL REQUIREMENTS AND REMARK

WARNING
The display glass may break when it is dropped or bumped on a hard surface. Handle with care. Should the display break, do not touch the electrophoretic material. In case of contact with electrophoretic material, wash with water and soap.

REMARK
All The specifications listed in this document are guaranteed for module only. Post-assembled operation or component(s) may impact module performance or cause unexpected effect or damage and therefore listed specifications is not warranted after any Post-assembled operation.

CAUTION
The display module should not be exposed to harmful gases, such as acid and alkali gases, which corrode electronic components.
Disassembling the display module can cause permanent damage and invalidate the warranty agreements.
IPA solvent can only be applied on active area and the back of a glass. For the rest part, it is not allowed.

Mounting Precautions
(1) It's recommended that you consider the mounting structure so that uneven force (ex. Twisted stress) is not applied to the module.
(2) It's recommended that you attach a transparent protective plate to the surface in order to protect the EPD. Transparent protective plate should have sufficient strength in order to resist external force.
(3) You should adopt radiation structure to satisfy the temperature specification.
(4) Acetic acid type and chlorine type materials for the cover case are not desirable because the former generates corrosive gas of attacking the PS at high temperature and the latter causes circuit break by electro-chemical reaction.
(5) Do not touch, push or rub the exposed PS with glass, tweezers or anything harder than HB pencil lead. And please do not rub with dust clothes with chemical treatment. Do not touch the surface of PS for bare hand or greasy cloth. (Some cosmetics deteriorate the PS)
(6) When the surface becomes dusty, please wipe gently with absorbent cotton or other soft materials like chamois soaks with petroleum benzene. Normal-hexane is recommended for cleaning the adhesives used to attach the PS. Do not use acetone, toluene and alcohol because they cause chemical damage to the PS.

(7) Wipe off saliva or water drops as soon as possible. Their long time contact with PS causes deformations and color fading.

Data sheet status	
Product specification	This data sheet contains preliminary product specifications.
Limiting values	
Limiting values given are in accordance with the Absolute Maximum Rating System (IEC 134). Stress above one or more of the limiting values may cause permanent damage to the device. These are stress ratings only and operation of the device at these or at any other conditions above those given in the Characteristics sections of the specification is not implied. Exposure to limiting values for extended periods may affect device reliability.	
Application information	
Where application information is given, it is advisory and does not form part of the specification.	

Eink Confidential

11. Reliability test

	TEST	CONDITION	METHOD	REMARK
1	High-Temperature Operation	T = +50°C, RH = 30% for 240 hrs	IEC 60 068-2-2Bp	
2	Low-Temperature Operation	T = 0°C for 240 hrs	IEC 60 068-2-2Ab	
3	High-Temperature Storage	T = +70°C, RH=40% for 240 hrs Test in white pattern	IEC 60 068-2-2Bp	
4	Low-Temperature Storage	T = -25°C for 240 hrs Test in white pattern	IEC 60 068-2-1Ab	
5	High-Temperature, High-Humidity Operation	T = +40°C, RH = 90% for 168 hrs	IEC 60 068-2-3CA	
6	High Temperature, High- Humidity Storage	T = +60°C, RH=80% for 240hrs Test in white pattern	IEC 60 068-2-3CA	
7	Temperature Cycle	-25°C → +70°C, 100 Cycles 30min 30min Test in white pattern	IEC 60 068-2-14	
8	Solar radiation test	765 W/m ² for 168hrs, 40°C Test in white pattern	IEC60 068-2-5Sa	
9	Package Vibration	1.04G, Frequency: 10~500Hz Direction: X,Y,Z Duration: 1 hours in each direction	Full packed for shipment	
10	Package Drop Impact	Drop from height of 122 cm on concrete surface. Drop sequence: 1 corner, 3 edges, 6 faces One drop for each.	Full packed for shipment	
11	Electrostatic Effect (non-operating)	(Machine model)+/- 250V 0Ω, 200pF	IEC 62179, IEC 62180	
12	Stylus Tapping	POLYACETAL Pen: Top R:0.8mm Load: 300gf Speed: 30 times/ min Total 13,500times,		

Actual EMC level to be measured on customer application

Note: The protective film must be removed before temperature test.

< Criteria >

In the standard conditions, there is not display function NG issue occurred.
(Including : line defect, no image) All the cosmetic specification is judged before the reliability stress.

12. Border definition

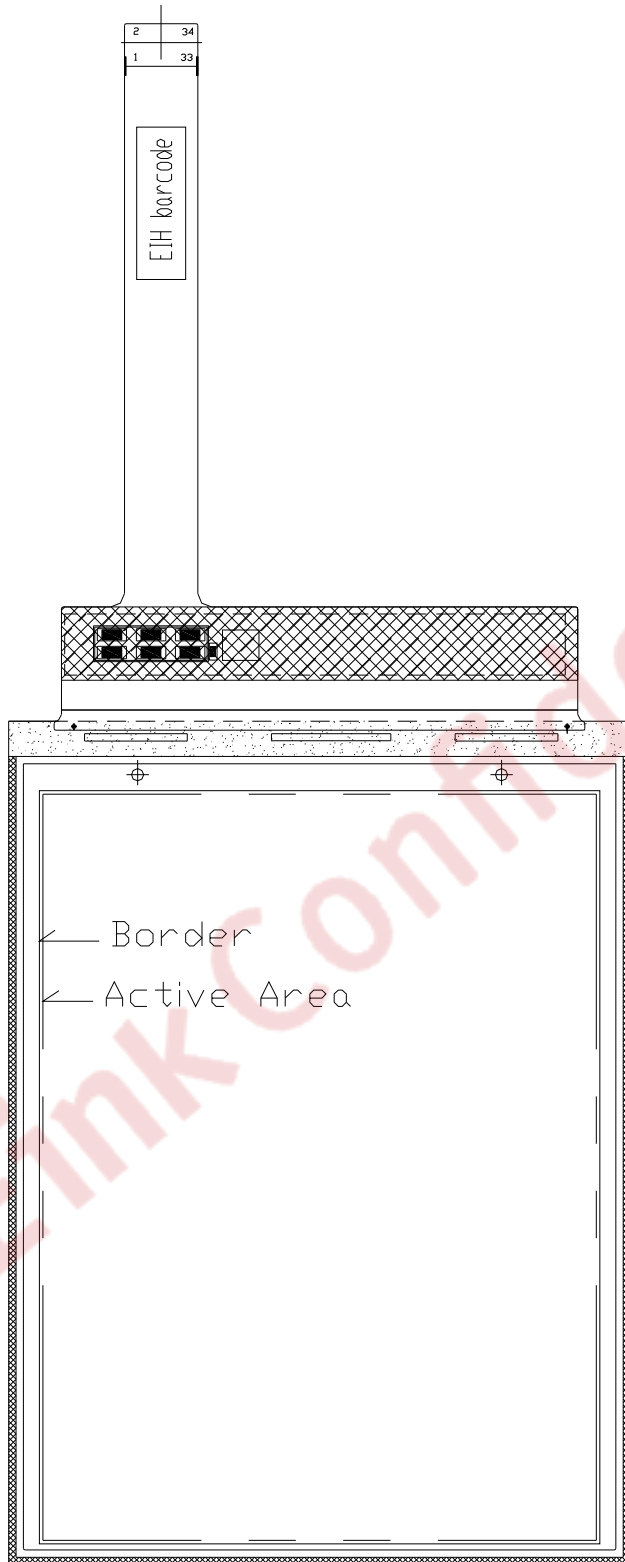

13. Block Diagram

