

Version : 1.0

TECHNICAL SPECIFICATION

MODEL NO : PD104SLK

The content of this information is subject to be changed without notice.
Please contact E Ink or its agent for further information.

Customer's Confirmation

Customer _____

Date _____

By _____

E Ink's Confirmation

Approve By 蘇倚徵
Confirmed By 傅源真
Prepared By 侯采君

Revision History

| Rev. | Issued Date | Revised Content |
|------|--------------|-----------------|
| 1.0 | May 30, 2012 | New |

TECHNICAL SPECIFICATION

CONTENTS

| <i>NO.</i> | <i>ITEM</i> | <i>PAGE</i> |
|------------|--------------------------------------|-------------|
| - | Cover | 1 |
| - | Revision History | 2 |
| - | Contents | 3 |
| 1 | Application | 4 |
| 2 | Features | 4 |
| 3 | Mechanical Specifications | 4 |
| 4 | Mechanical Drawing of TFT-LCD module | 5 |
| 5 | Input Terminals | 7 |
| 6 | Absolute Maximum Ratings | 9 |
| 7 | Electrical Characteristics | 9 |
| 8 | Power On/Off Sequence | 16 |
| 9 | Optical Characteristics | 17 |
| 10 | Handling Cautions | 20 |
| 11 | Reliability Test | 21 |
| 12 | Block Diagram | 22 |
| 13 | Packing | 23 |

1. Application

This data sheet applies to a color TFT LCD module, PD104SLK.

PD104SLK module applies to OA product, car TV(must use Analog to Digital drive board), which require high quality flat panel display. If you must use in high reliability environment can't over reliability test condition

Prime View assume no responsibility for any damage resulting from the use of the device which dose not comply with the instructions and the precautions in these specification sheet.

2. Features

- . Amorphous silicon TFT LCD panel with High Brightness LED back-light unit
- . Pixel in stripe configuration
- . Slim and compact, designed for O/A application
- . Display Colors : 262,144 colors
- . +3.3V DC supply voltage for TFT LCD panel driving
- . Backlight driving DC/AC inverter not included in this module
- . Wide Viewing Angle

3. Mechanical Specifications

| Parameter | Specifications | Unit |
|--------------------------------|-------------------------------------|------|
| Screen Size | 10.4 (diagonal) | inch |
| Display Format | 800×(R, G, B)×600 | dot |
| Display Colors | 262,144 | |
| Active Area | 211.2(H)×158.4 (V) | mm |
| Pixel Pitch | 0.264 (H)×0.264 (V) | mm |
| Pixel Configuration | Stripe | |
| Outline Dimension | 243.0 (w)×185.1(H)×18.715(typ.) (D) | mm |
| Weight | 590±20 | g |
| Back-light | 11- LED | |
| Surface treatment | Anti-glare and EWV | |
| Display mode | Normally white | |
| Gray scale inversion direction | 6 o'clock [ref to Note 9-1] | |

4. Mechanical Drawing of TFT-LCD Module

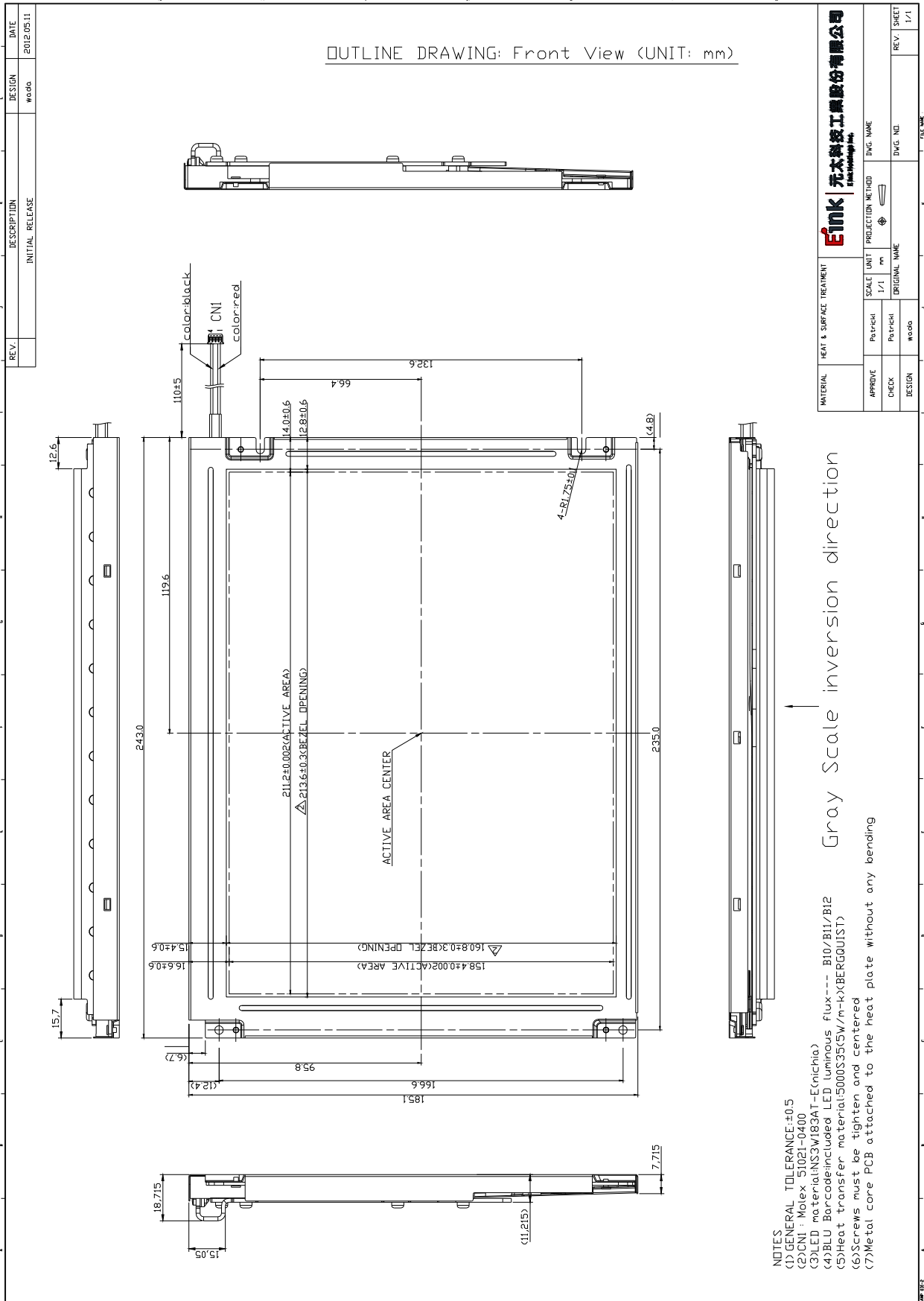

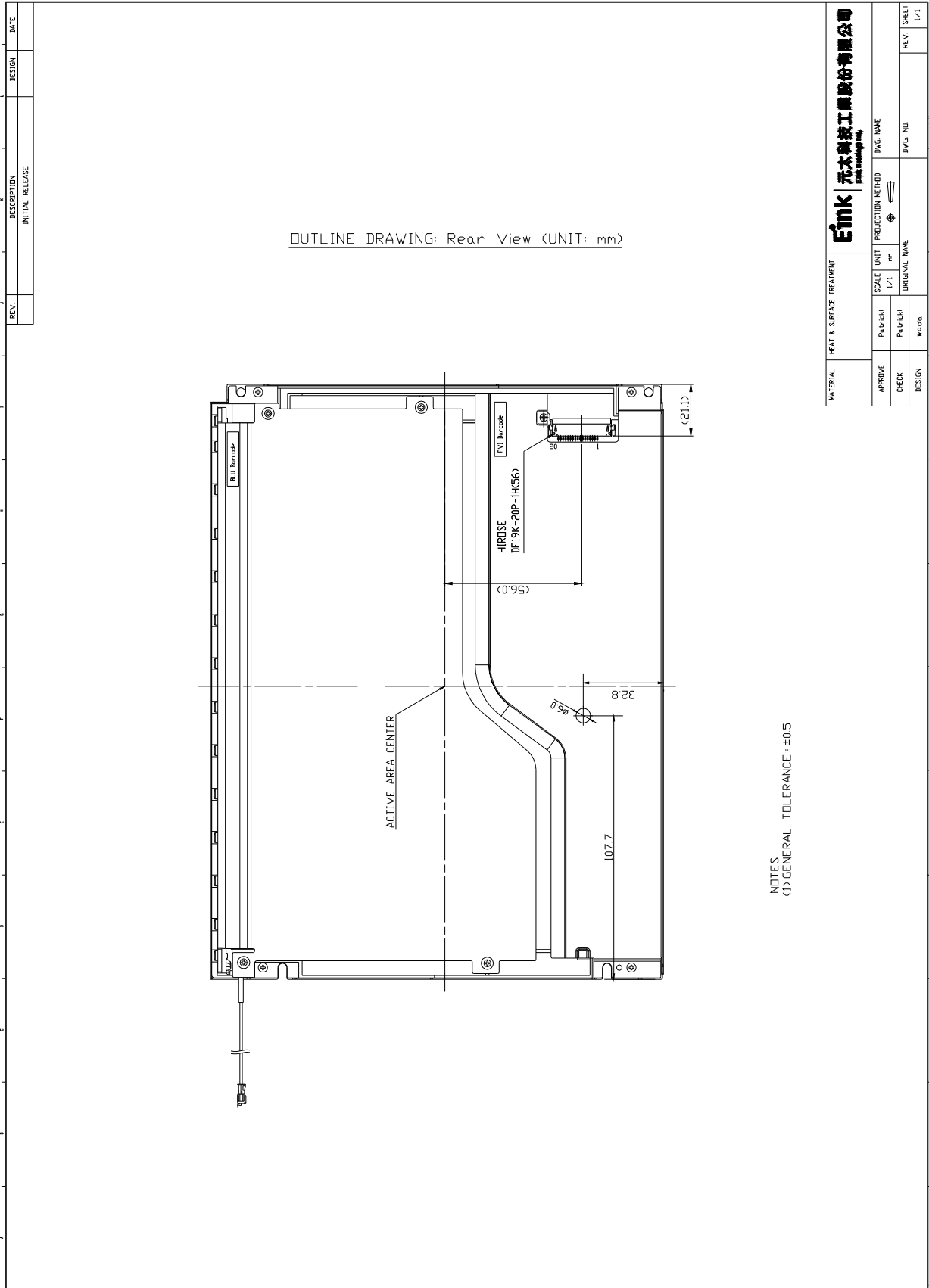

5. Input Terminals

5-1) TFT-LCD Panel Driving

Connector type: HIROSE DF19K-20P-1H(56)

| Pin No. | Symbol | Function | Remark |
|---------|-----------------|--------------------------------|--------|
| 1 | V _{DD} | +3.3V Power Supply | |
| 2 | V _{DD} | +3.3V Power Supply | |
| 3 | GND | Ground | |
| 4 | GND | Ground | |
| 5 | INO- | LVDS receiver signal channel 0 | |
| 6 | INO+ | LVDS receiver signal channel 0 | |
| 7 | GND | Ground | |
| 8 | IN1- | LVDS receiver signal channel 1 | |
| 9 | IN1+ | LVDS receiver signal channel 1 | |
| 10 | GND | Ground | |
| 11 | IN2- | LVDS receiver signal channel 2 | |
| 12 | IN2+ | LVDS receiver signal channel 2 | |
| 13 | GND | Ground | |
| 14 | CLK- | LVDS receiver signal clock | |
| 15 | CLK+ | LVDS receiver signal clock | |
| 16 | GND | Ground | |
| 17 | NC | No connection | |
| 18 | NC | No connection | |
| 19 | GND | Ground | |
| 20 | GND | Ground | |

PD104SLK

Recommended Transmitter (THC63LVDM63A Thine) to PD104SLK interface Assignment:

| Input terminal of THC63LVDM63A | | Graphic controller output signal | | Output signal symbol | To PD104SLK interface terminal(Symbol) |
|--------------------------------|-----|----------------------------------|---------------------------------|------------------------|--|
| Symbol | No. | Symbol | Function | | |
| TIN0 | 44 | R0 | Red pixel data (LSB) | Tout0- Tout0+ | No.5 : IN0- No.6 : IN0+ |
| TIN1 | 45 | R1 | Red pixel data | | |
| TIN2 | 47 | R2 | Red pixel data | | |
| TIN3 | 48 | R3 | Red pixel data | | |
| TIN4 | 1 | R4 | Red pixel data | | |
| TIN5 | 3 | R5 | Red pixel data(MSB) | Tout1- Tout1+ | No.7 : IN1- No.8 : IN1+ |
| TIN6 | 4 | G0 | Green pixel data (LSB) | | |
| TIN7 | 6 | G1 | Green pixel data | | |
| TIN8 | 7 | G2 | Green pixel data | | |
| TIN9 | 9 | G3 | Green pixel data | | |
| TIN10 | 10 | G4 | Green pixel data | Tout2- Tout2+ | No.9 : IN2- No.10 : IN2+ |
| TIN11 | 12 | G5 | Green pixel data(MSB) | | |
| TIN12 | 13 | B0 | Blue pixel data(LSB) | | |
| TIN13 | 15 | B1 | Blue pixel data | | |
| TIN14 | 16 | B2 | Blue pixel data | | |
| TIN15 | 18 | B3 | Blue pixel data | TCLK out- TCLK out+ | No.11 : CLK - No.12 : CLK + |
| TIN16 | 19 | B4 | Blue pixel data | | |
| TIN17 | 20 | B5 | Blue pixel data(MSB) | | |
| TIN18 | 22 | HSYNC | Horizontal sync signal | | |
| TIN19 | 23 | VSYNC | Vertical sync signal | | |
| TIN20 | 25 | DENB | Compound Synchronization signal | | |
| TCLK in | 26 | CLK | Data sampling clock | | |

LVDS Interface Block Diagram

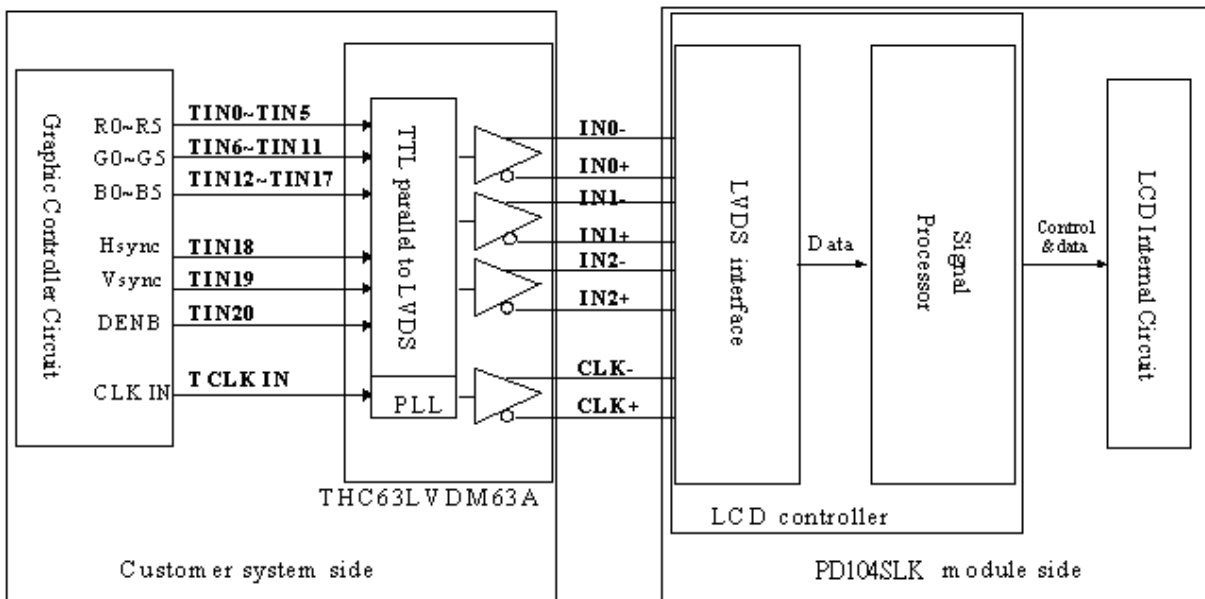

5-2) Backlight driving

Connector type : MOLEX 51021-0400

| Pin No | Symbol | Description | Remark |
|--------|--------|---------------------------|--------------------|
| 1 | + | Input terminal (Anode) | Wire color : Red |
| 4 | - | Input terminal (Cathode)) | Wire Color : Black |

6. Absolute Maximum Ratings:

GND=0V, Ta=25°C

| Parameters | Symbol | MIN. | MAX. | Unit | Remark |
|-----------------------|-----------------|------|---------|------|----------|
| Supply Voltage | V _{DD} | -0.3 | +4.0 | V | |
| Input Signals Voltage | V _{IN} | -0.3 | VDD+0.3 | V | Note 6-1 |

Note 6-1: LVDS signal.

7. Electrical Characteristics

7-1) Recommended Operating Conditions:

GND = 0V , Ta = 25°C

| Item | Symbol | Min. | Typ. | Max. | Unit | Remark |
|--|-----------------|------|------|------|------|----------|
| Supply Voltage | VDD | 3.0 | 3.3 | 3.6 | V | |
| Current Dissipation | I _{DD} | - | 190 | 380 | mA | Note 7-1 |
| LVDS Differential input high threshold | V _{TH} | - | - | 100 | mV | Note 7-2 |
| LVDS Differential input low threshold | V _{TL} | -100 | - | - | | |

Note 7-1 : To test the current dissipation of VDD, using the “color bars” testing pattern shown as below

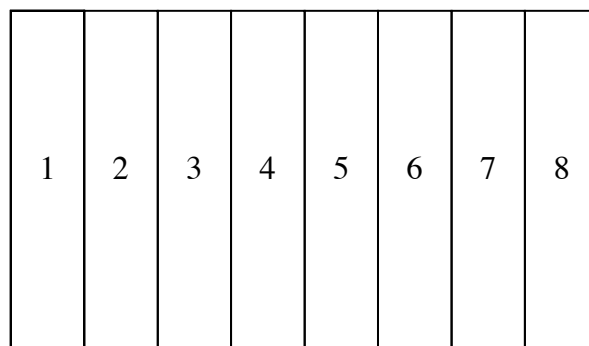

1. White
2. Yellow
3. Cyan
4. Green
5. Magenta
6. Red
7. Blue
8. Black

I_{DD} current dissipation testing pattern

Note 7-2 :Please refers to THC63LVDF63A specification by THINE Corporation. This LCD module conforms to LVDS standard.

7-2) Recommended Driving Condition for Back Light

Ta = 25°C

| Parameter | Symbol | Min | TYP | MAX | Unit | Remark |
|---------------------------------|-----------|-----|-----|------|------|---------------------|
| Supply voltage of LED backlight | V_{LED} | - | - | 39.6 | V | Note 7-3 |
| Supply current of LED backlight | I_{LED} | - | 165 | - | mA | Note 7-4 |
| Backlight Power Consumption | P_{LED} | - | - | 6.5 | W | Note 7-3 / Note 7-5 |

Note 7-3 : $I_{LED} = 165\text{mA}$ (Constant Current). Customer system design for driving should be constant current.

Note 7-4 : The LED driving condition is defined for each LED module. (11 LED Serial)

Input current = 165mA

Note 7-5: $(P_{LED})_{MAX} = (V_{LED})_{MAX} * (I_{LED})_{TYP}$

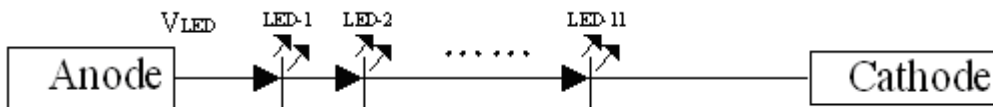

7-3) Input signal timing :

DENB pin have high priority than SYNC mode (HSVC+VSYNC). When IC only use SYNC pin, DENB pin have to connect to ground.

(A) Timing Specifications (DENB Mode):

| Item | Symbol | Min. | Typ. | Max. | Unit | Remark |
|---------------------------|--------|----------|-----------|-----------|------|--------|
| Frame Cycling Period | t1 | 604 X t3 | 628X t3 | 800 X t3 | - | |
| | | 14 | 16.58 | 20 | ms | |
| Vertical Display Period | t2 | 600 X t3 | 600 X t3 | 600 X t3 | - | |
| Horizontal Scanning Time | t3 | 920 X t5 | 1056 X t5 | 1064 X t5 | - | |
| | | 24 | 26.4 | 33 | μs | |
| Horizontal Display Period | t4 | 800 X t5 | 800 X t5 | 800 X t5 | - | |
| Clock Cycle | t5 | 20 | 25.0 | 31.25 | ns | |
| Clock High Level Time | t6 | 9.0 | - | - | ns | |
| Clock Low Level Time | t7 | 9.0 | - | - | ns | |
| Hold time | t8 | 4.0 | - | - | ns | |
| Set-up time | t9 | 5.0 | - | - | ns | |

(B). Timing Specifications (SYNC Mode)

| Item | Symbol | Min. | Typ. | Max. | Unit | Remark | |
|-------------|----------------------------------|------|------|-------|-------|--------|--------|
| HSYNC | Period | 24 | 26.4 | 33 | us | | |
| | | 920 | 1056 | 1064 | tc | | |
| | Display period | Hdp | 800 | 800 | 800 | tc | |
| | Pulse width | Hpw | 12 | 128 | 202 | tc | |
| | Back-porch | Hbp | 12 | 86 | 202 | tc | |
| | Front-porch | Hfp | 42 | 42 | 42 | tc | |
| | Hpw+Hbp | | 214 | 214 | 214 | tc | |
| | Hsync-CLK | Hhc | 10 | - | Tc-10 | ns | |
| Vsync-Hsync | Hvh | 0 | 0 | 200 | tc | | |
| VSYNC | Period (Frame cycling period) | Vp | 14 | 16.58 | 20 | ms | Note 1 |
| | | | 604 | 628 | 800 | Hp | |
| | Display period | Vdp | 600 | 600 | 600 | Hp | |
| | Pulse width | Vpw | 2 | 4 | 27 | Hp | |
| | Back-porch | Vbp | 0 | 23 | 25 | Hp | |
| | Front-porch | Vfp | 1 | 1 | 1 | Hp | |
| | Vpw+Vbp | | 27 | 27 | 27 | Hp | |

Note 1 : Frame cycling period is optimum in 16.58ms.(60Hz)

(C)Timing Chart:

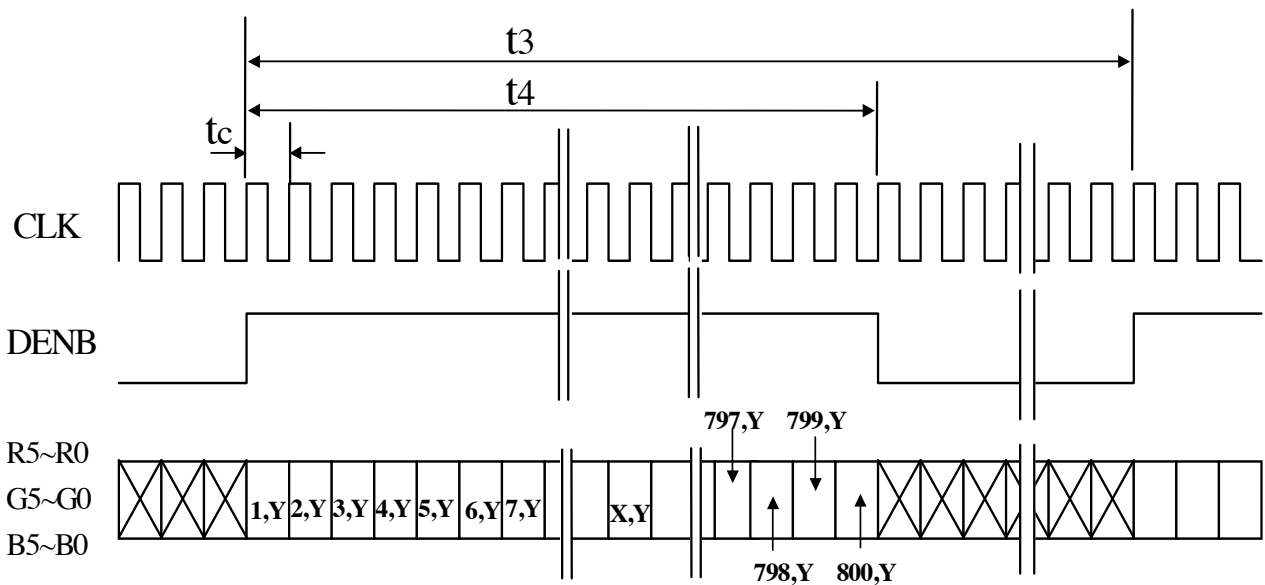
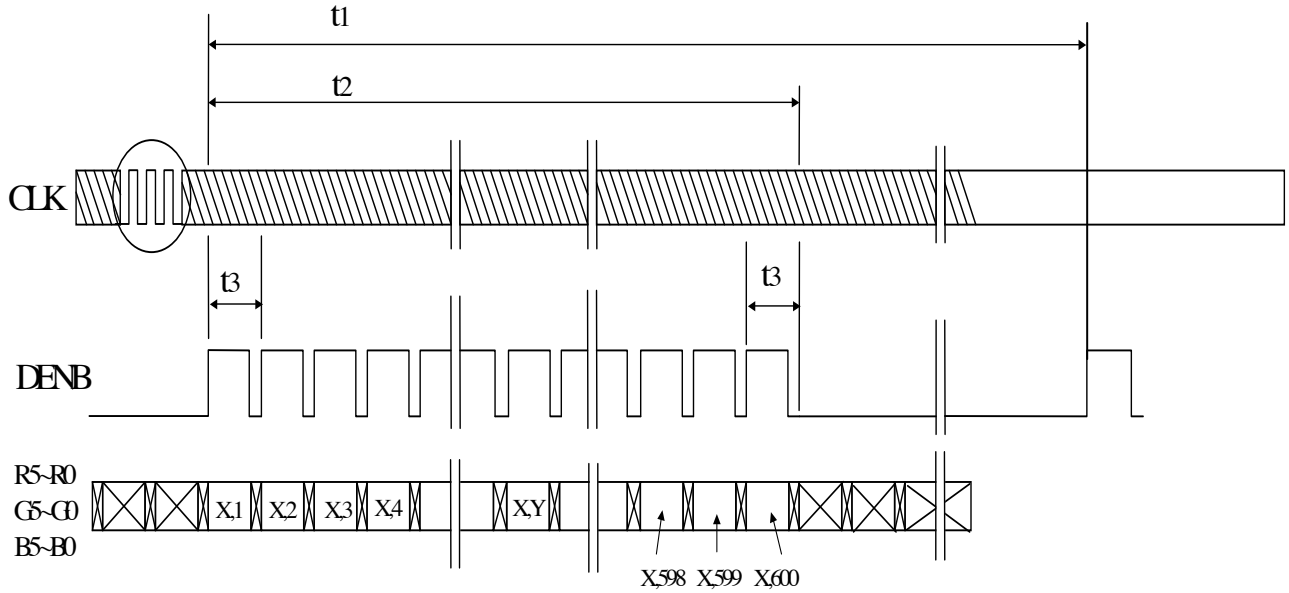

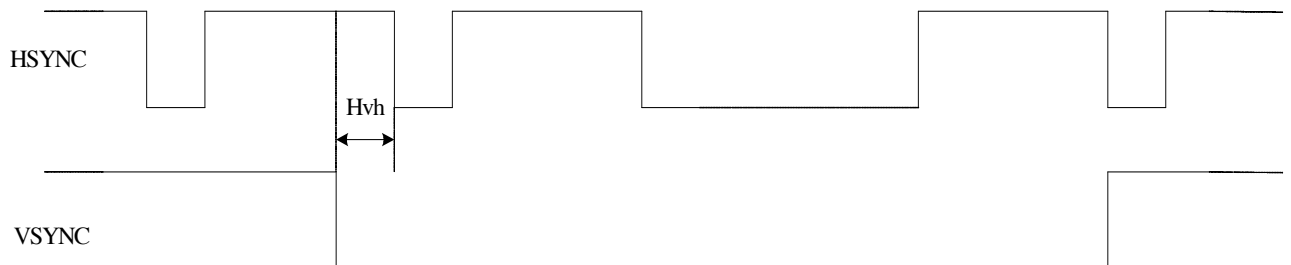
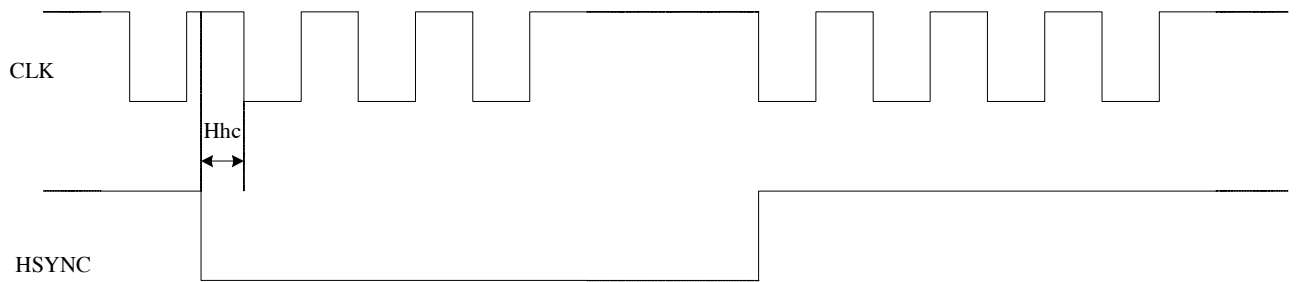
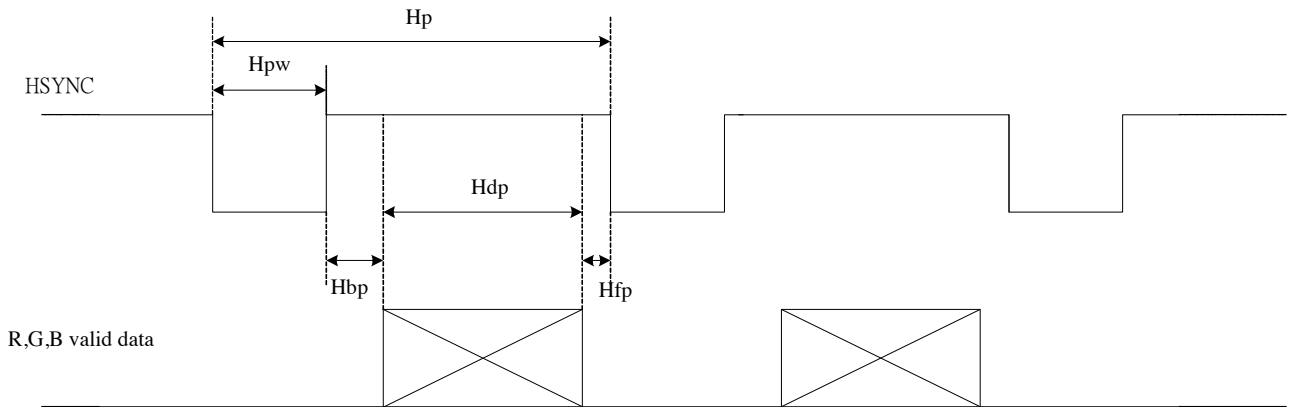

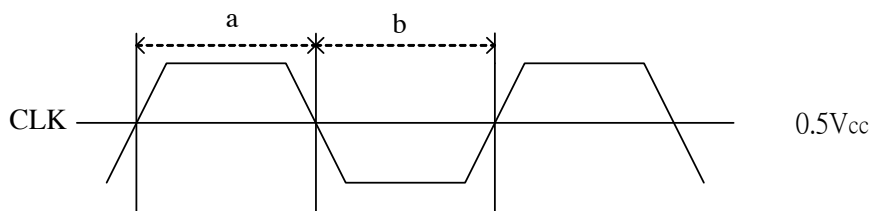
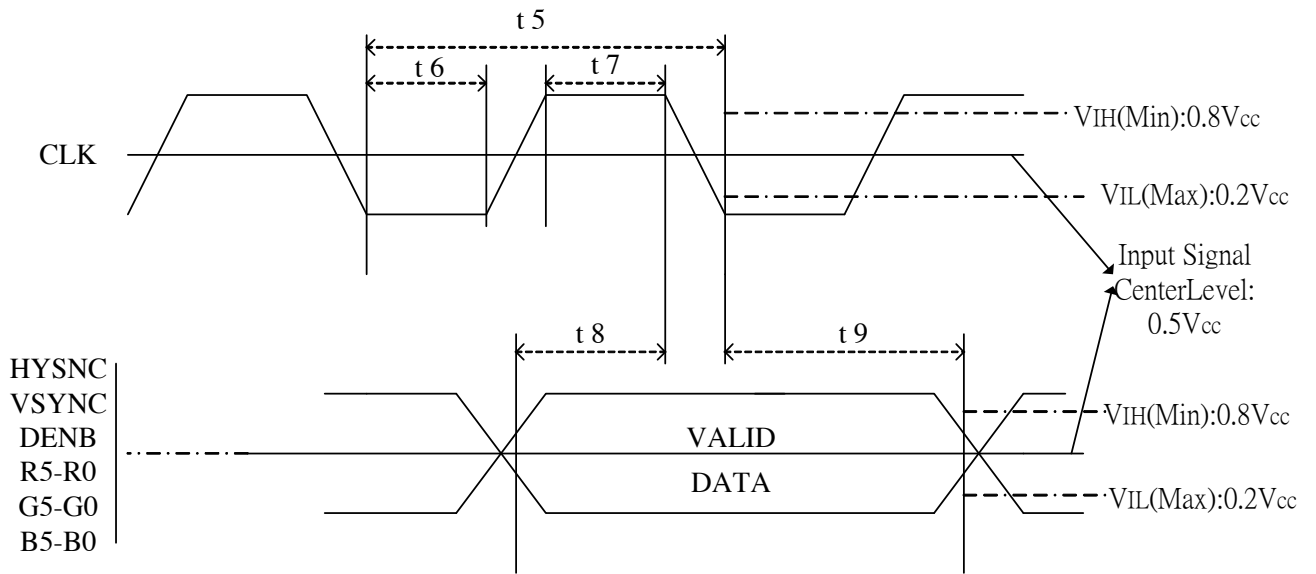
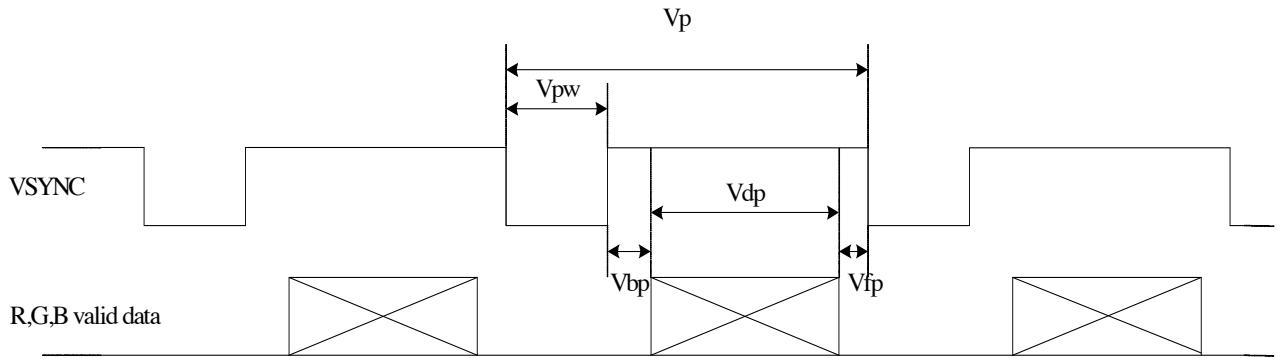

Duty (a , b) : $50 \pm 10\%$

7-4) Display Color and Gray Scale Reference

| Color | | Input Color Data | | | | | | | | | | | | | | | | | |
|--------------|------------|------------------|----|----|----|----|----|-------|----|----|----|----|----|------|----|----|----|----|----|
| | | Red | | | | | | Green | | | | | | Blue | | | | | |
| | | R5 | R4 | R3 | R2 | R1 | R0 | G5 | G4 | G3 | G2 | G1 | G0 | B5 | B4 | B3 | B2 | B1 | B0 |
| Basic Colors | Black | 0 | 0 | 0 | 0 | 0 | 0 | 0 | 0 | 0 | 0 | 0 | 0 | 0 | 0 | 0 | 0 | 0 | 0 |
| | Red (63) | 1 | 1 | 1 | 1 | 1 | 1 | 0 | 0 | 0 | 0 | 0 | 0 | 0 | 0 | 0 | 0 | 0 | 0 |
| | Green (63) | 0 | 0 | 0 | 0 | 0 | 0 | 1 | 1 | 1 | 1 | 1 | 1 | 0 | 0 | 0 | 0 | 0 | 0 |
| | Blue (63) | 0 | 0 | 0 | 0 | 0 | 0 | 0 | 0 | 0 | 0 | 0 | 0 | 1 | 1 | 1 | 1 | 1 | 1 |
| | Cyan | 0 | 0 | 0 | 0 | 0 | 0 | 1 | 1 | 1 | 1 | 1 | 1 | 1 | 1 | 1 | 1 | 1 | 1 |
| | Magenta | 1 | 1 | 1 | 1 | 1 | 1 | 0 | 0 | 0 | 0 | 0 | 0 | 1 | 1 | 1 | 1 | 1 | 1 |
| | Yellow | 1 | 1 | 1 | 1 | 1 | 1 | 1 | 1 | 1 | 1 | 1 | 1 | 0 | 0 | 0 | 0 | 0 | 0 |
| | White | 1 | 1 | 1 | 1 | 1 | 1 | 1 | 1 | 1 | 1 | 1 | 1 | 1 | 1 | 1 | 1 | 1 | 1 |
| Red | Red (00) | 0 | 0 | 0 | 0 | 0 | 0 | 0 | 0 | 0 | 0 | 0 | 0 | 0 | 0 | 0 | 0 | 0 | 0 |
| | Red (01) | 0 | 0 | 0 | 0 | 0 | 1 | 0 | 0 | 0 | 0 | 0 | 0 | 0 | 0 | 0 | 0 | 0 | 0 |
| | Red (02) | 0 | 0 | 0 | 0 | 1 | 0 | 0 | 0 | 0 | 0 | 0 | 0 | 0 | 0 | 0 | 0 | 0 | 0 |
| | Darker | | | | | | | | | | | | | | | | | | |
| | ↓ | ↓ | ↓ | ↓ | ↓ | ↓ | ↓ | ↓ | ↓ | ↓ | ↓ | ↓ | ↓ | ↓ | ↓ | ↓ | ↓ | ↓ | ↓ |
| | Brighter | | | | | | | | | | | | | | | | | | |
| | Red (61) | 1 | 1 | 1 | 1 | 0 | 1 | 0 | 0 | 0 | 0 | 0 | 0 | 0 | 0 | 0 | 0 | 0 | 0 |
| | Red (62) | 1 | 1 | 1 | 1 | 1 | 0 | 0 | 0 | 0 | 0 | 0 | 0 | 0 | 0 | 0 | 0 | 0 | 0 |
| Red (63) | 1 | 1 | 1 | 1 | 1 | 1 | 0 | 0 | 0 | 0 | 0 | 0 | 0 | 0 | 0 | 0 | 0 | 0 | |
| Green | Green (00) | 0 | 0 | 0 | 0 | 0 | 0 | 0 | 0 | 0 | 0 | 0 | 0 | 0 | 0 | 0 | 0 | 0 | 0 |
| | Green (01) | 0 | 0 | 0 | 0 | 0 | 0 | 0 | 0 | 0 | 0 | 0 | 1 | 0 | 0 | 0 | 0 | 0 | 0 |
| | Green (02) | 0 | 0 | 0 | 0 | 0 | 0 | 0 | 0 | 0 | 0 | 1 | 0 | 0 | 0 | 0 | 0 | 0 | 0 |
| | Darker | | | | | | | | | | | | | | | | | | |
| | ↓ | ↓ | ↓ | ↓ | ↓ | ↓ | ↓ | ↓ | ↓ | ↓ | ↓ | ↓ | ↓ | ↓ | ↓ | ↓ | ↓ | ↓ | ↓ |
| | Brighter | | | | | | | | | | | | | | | | | | |
| | Green (61) | 0 | 0 | 0 | 0 | 0 | 0 | 1 | 1 | 1 | 1 | 0 | 1 | 0 | 0 | 0 | 0 | 0 | 0 |
| | Green (62) | 0 | 0 | 0 | 0 | 0 | 0 | 1 | 1 | 1 | 1 | 1 | 0 | 0 | 0 | 0 | 0 | 0 | 0 |
| Green (63) | 0 | 0 | 0 | 0 | 0 | 0 | 1 | 1 | 1 | 1 | 1 | 1 | 0 | 0 | 0 | 0 | 0 | 0 | |
| Blue | Blue (00) | 0 | 0 | 0 | 0 | 0 | 0 | 0 | 0 | 0 | 0 | 0 | 0 | 0 | 0 | 0 | 0 | 0 | 0 |
| | Blue (01) | 0 | 0 | 0 | 0 | 0 | 0 | 0 | 0 | 0 | 0 | 0 | 0 | 0 | 0 | 0 | 0 | 0 | 1 |
| | Blue (02) | 0 | 0 | 0 | 0 | 0 | 0 | 0 | 0 | 0 | 0 | 0 | 0 | 0 | 0 | 0 | 0 | 1 | 0 |
| | Darker | | | | | | | | | | | | | | | | | | |
| | ↓ | ↓ | ↓ | ↓ | ↓ | ↓ | ↓ | ↓ | ↓ | ↓ | ↓ | ↓ | ↓ | ↓ | ↓ | ↓ | ↓ | ↓ | ↓ |
| | Brighter | | | | | | | | | | | | | | | | | | |
| | Blue (61) | 0 | 0 | 0 | 0 | 0 | 0 | 0 | 0 | 0 | 0 | 0 | 0 | 1 | 1 | 1 | 1 | 0 | 1 |
| | Blue (62) | 0 | 0 | 0 | 0 | 0 | 0 | 0 | 0 | 0 | 0 | 0 | 0 | 1 | 1 | 1 | 1 | 1 | 0 |
| Blue (63) | 0 | 0 | 0 | 0 | 0 | 0 | 0 | 0 | 0 | 0 | 0 | 0 | 1 | 1 | 1 | 1 | 1 | 1 | |

7-5) Pixel Arrangement

The LCD module pixel arrangement is the stripe.

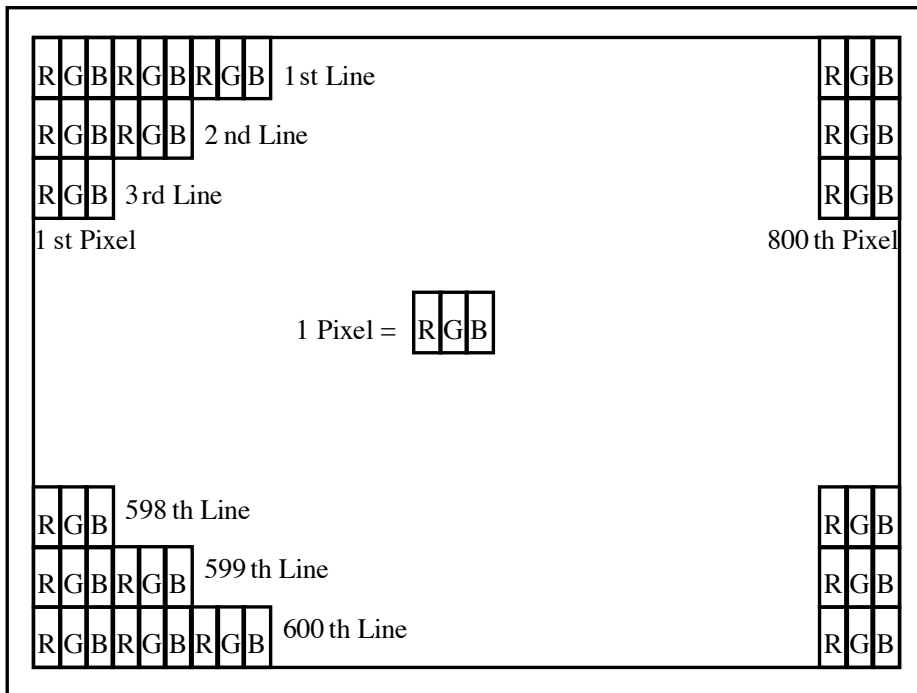

8 .Power On/Off Sequence

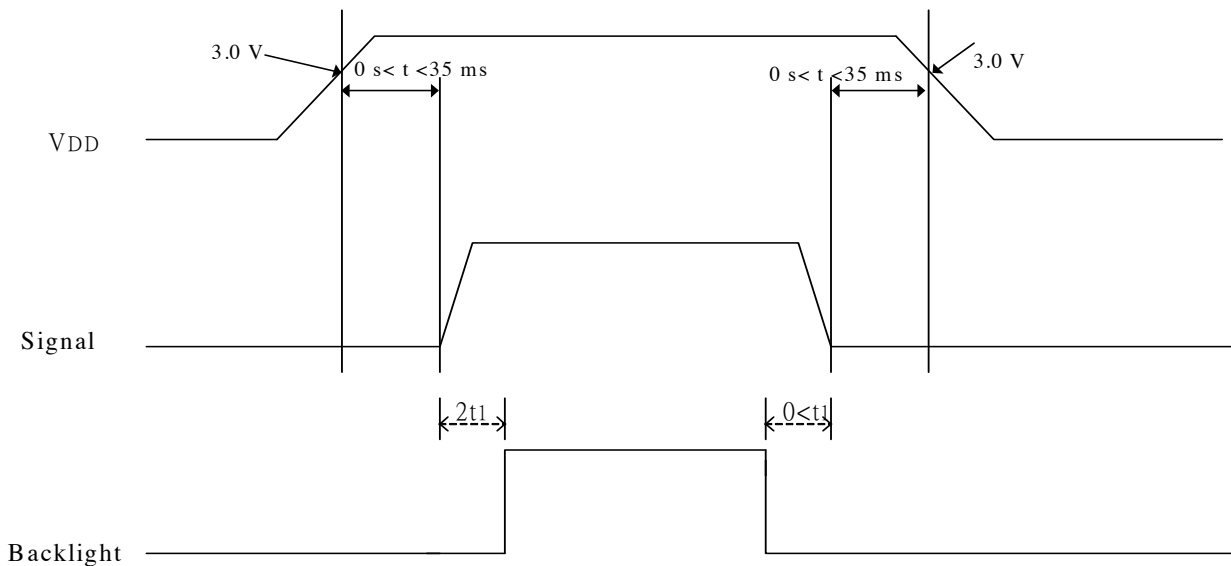

1. The supply voltage for input signals should be same as V_{DD} .
2. When the power is off , please keep whole signals (Hsync,Vsync,DENB,CLK, Data) low level or high impedance.

9.) Optical Characteristics

9-1) Specification:

Ta = +25°C

| Parameter | Symbol | Condition | MIN. | TYP. | MAX. | Unit | Remarks |
|----------------------|------------|--|----------|----------|------|-------------------|----------|
| Viewing Angle | Horizontal | θ 21.22 | ± 65 | ± 75 | - | deg | Note 9-1 |
| | Vertical | θ (to 12 o'clock) | 40 | 50 | - | deg | |
| | | θ (to 6 o'clock) | 50 | 60 | - | deg | |
| Contrast Ratio | CR | $\theta = 0^\circ$ | 500 | 800 | - | - | Note 9-2 |
| Brightness | L | $\theta = 0^\circ / \varphi = 0^\circ$ | 1000 | 1200 | - | cd/m ² | Note 9-3 |
| Response time | Rise | Tr | - | 10 | 15 | ms | Note 9-4 |
| | Fall | Tf | - | 20 | 25 | ms | |
| Luminance Uniformity | U | - | 70 | 80 | - | % | Note 9-5 |
| White Chromaticity | x | $\theta = 0^\circ / \varphi = 0^\circ$ | 0.28 | 0.33 | 0.38 | - | |
| | y | | 0.33 | 0.38 | 0.43 | - | |
| Cross Talk Ratio | CTK | $\theta = 0^\circ / \varphi = 0^\circ$ | - | - | 3.5 | % | Note 9-6 |
| LED Life Time | - | +25°C | 50000 | - | - | hrs | Note 9-7 |

All the optical measurement shall be executed 30 minutes after backlight being turn-on. The optical characteristics shall be measured in dark room (ambient illumination on panel surface less than 1 Lux). The measuring configuration shows as following figure.

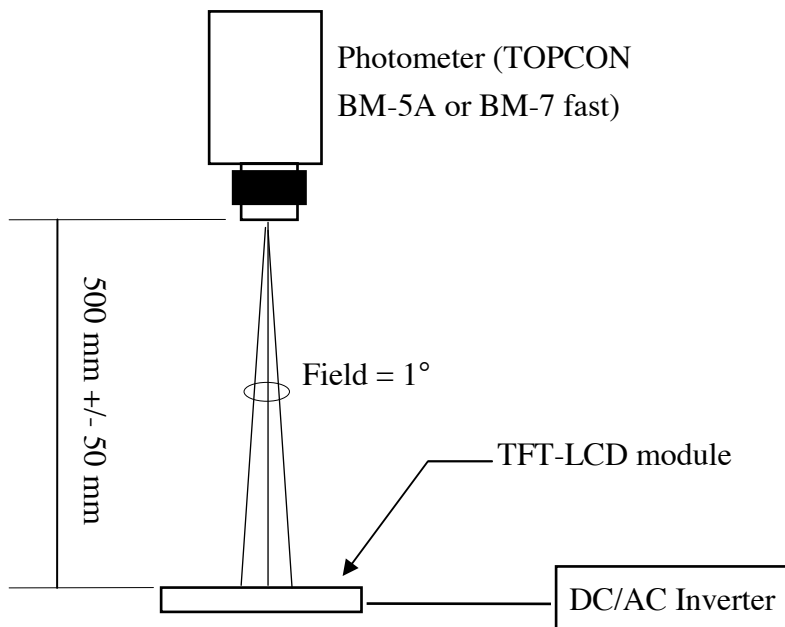

Optical characteristics measuring configuration

Note 9-1 : The definitions of viewing angles are as follows.

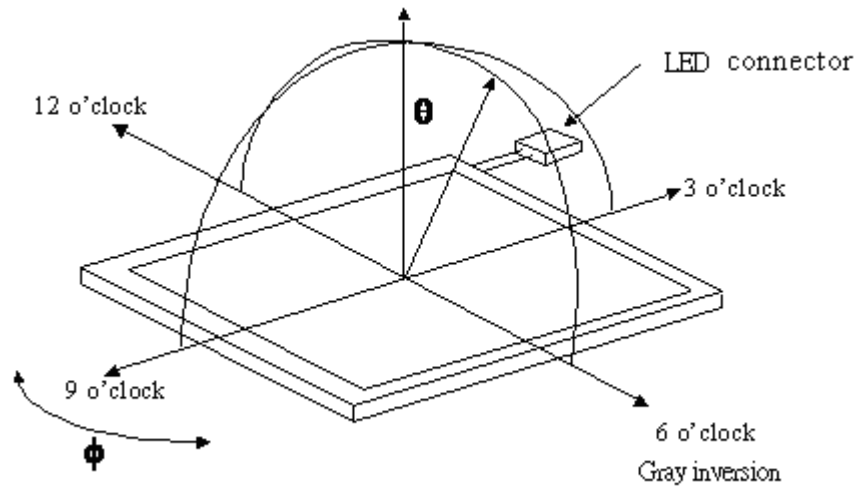

Note 9-2 : The definition of contrast ratio $CR = \frac{\text{Luminance at gray level 63}}{\text{Luminance at gray level 0}}$

Note 9-3 : Topcon BM-5A or BM-7 fast luminance meter 1° field of view is used in the testing .

Note 9-4: Definition of Response Time T_r and T_f :

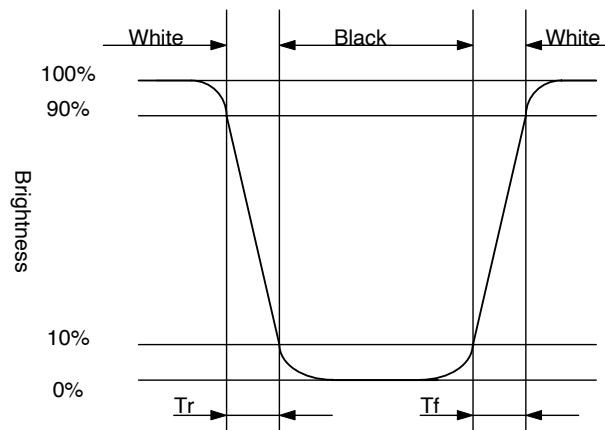

Note 9-5: The uniformity of LCD is defined as

$$U = \frac{\text{The Minimum Brightness of the 9 testing Points}}{\text{The Maximum Brightness of the 9 testing Points}}$$

Luminance meter : BM-5A or BM-7 fast(TOPCON)

Measurement distance : 500 mm +/- 50 mm

Ambient illumination : < 1 Lux

Measuring direction : Perpendicular to the surface of module

The test pattern is white (Gray Level 63).

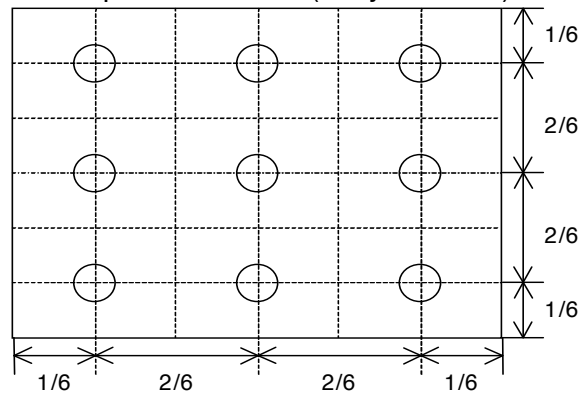

Note 9-6: Cross Talk (CTK) = $\frac{|YA-YB|}{YA} \times 100\%$

YA: Brightness of Pattern A

YB: Brightness of Pattern B

Luminance meter : BM 5A or BM-7 fast (TOPCON)

Measurement distance : 500 mm +/- 50 mm

Ambient illumination : < 1 Lux

Measuring direction : Perpendicular to the surface of module

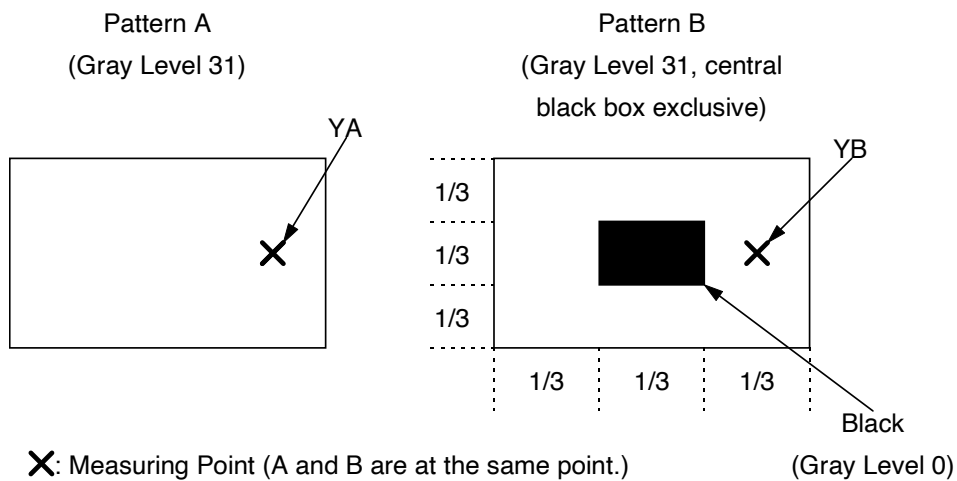

Note 9-7: The “LED Life time “ is defined as the module brightness decrease to 50% original Brightness that the ambient temperature is 25°C and $I_{LED} = 165 \text{ mA}$ (1 light bar).

As the performance of an LED may differ when assembled as a monitor together with a TFT panel due to different environmental temperature.

Estimated lifetime could vary on a different temperature and usually higher temperature could reduce the life significantly.

10. Handling Cautions

10-1) Mounting of module

- a) Please power off the module when you connect the input/output connector.
- b) Polarizer which is made of soft material and susceptible to flaw must be handled carefully.
- c) Protective film (Laminator) is applied on surface to protect it against scratches and dirt.
- d) Please following the tear off direction as figure 10-1 to remove the protective film as slowly as possible, so that electrostatic charge can be minimized.

10-2) Precautions in mounting

- a) When metal part of the TFT-LCD module (shielding lid and rear case) is soiled, wipe it with soft dry cloth.
- b) Wipe off water drops or finger grease immediately. Long contact with water may cause discoloration or spots.
- c) TFT-LCD module uses glass which breaks or cracks easily if dropped or bumped on hard surface. Please handle with care.
- d) Since CMOS LSI is used in the module. So take care of static electricity and earth yourself when handling.

10-3) Adjusting module

- a) Adjusting volumes on the rear face of the module have been set optimally before shipment.
- b) Therefore, do not change any adjusted values. If adjusted values are changed, the specifications described may not be satisfied.

10-4) Polarizer mark

The polarizer mark is to describe the direction of wide view angle film how to mach up with the rubbing direction.

10-5) Others

- a) Do not expose the module to direct sunlight or intensive ultraviolet rays for many hours.
- b) Store the module at a room temperature place.
- c) The voltage of beginning electric discharge may over the normal voltage because of leakage current from approach conductor by to draw lump read lead line around.
- d) If LCD panel breaks, it is possibly that the liquid crystal escapes from the panel. Avoid putting it into eyes or mouth. When liquid crystal sticks on hands, clothes or feet. Wash it out immediately with soap.
- e) Observe all other precautionary requirements in handling general electronic components.
- f) Please adjust the voltage of common electrode as material of attachment by 1 module.

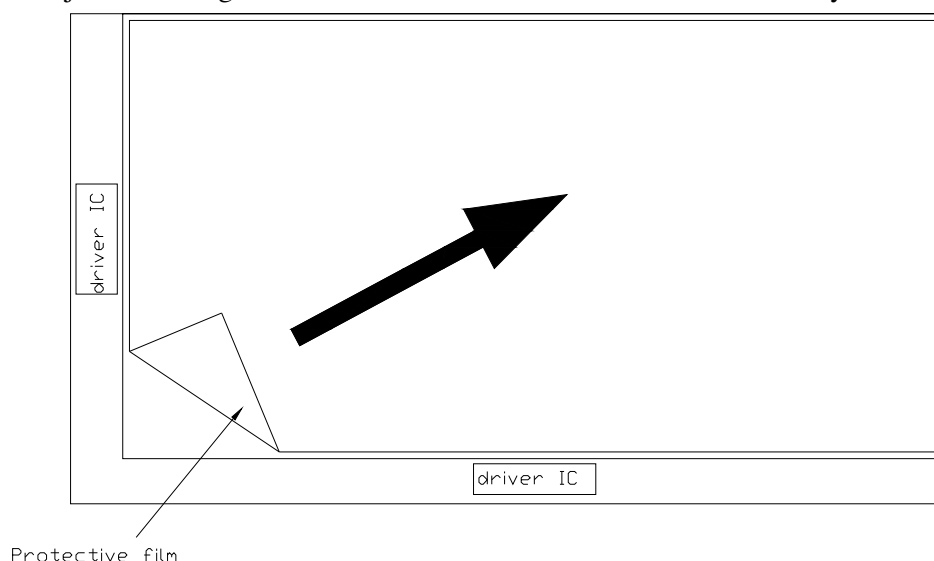

Figure 10-1 the way to peel off protective film

11. Reliability Test

| No | Test Item | Test Condition | Remark |
|----|---|--|--------|
| 1 | High Temperature Storage Test | Ta = +80°C, 240 hrs | |
| 2 | Low Temperature Storage Test | Ta = -30°C, 240 hrs | |
| 3 | High Temperature Operation Test | Ta = +80°C, 240 hrs | |
| 4 | Low Temperature Operation Test | Ta = -30°C, 240 hrs | |
| 5 | High Temperature & High Humidity Operation Test | Ta = +60°C, 90%RH, 240 hrs (No Condensation) | |
| 6 | Thermal Cycling Test (non-operating) | 0°C ↔ +60°C, 100 Cycles 1Hr 1Hr | |
| 7 | Vibration Test (non-operating) | Frequency : 10 ~ 57 Hz, Amplitude : 0.15 mm, 58~500Hz, 1G Sweep time: 11 min Test Period: 3 hrs (1 hr for each direction of X, Y, Z) | |
| 8 | Shock Test (non-operating) | 80G, 6ms, X,Y, Z 1 times for each direction | |
| 9 | Electron Static Discharge | C=150pF, R=330Ω Contact=±8KV Air=±15KV 10 times/terminal | |

Ta: ambient temperature

Note: The protective film must be removed before temperature test

[Criteria]

In the standard conditions, there is not display function NG issue occurred. (including : line defect ,no image). All the cosmetic specification is judged before the reliability stress.

12. Block Diagram

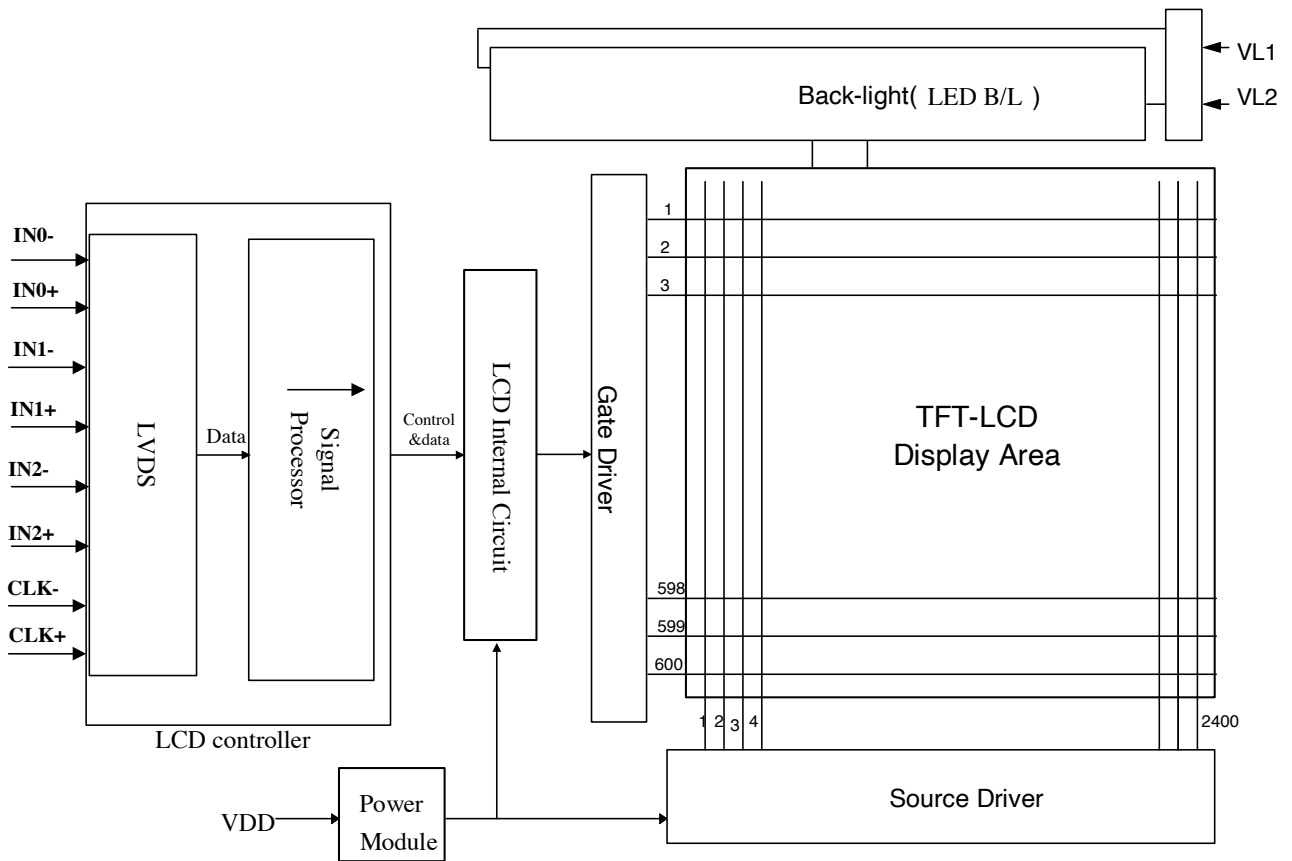

13.Packing

| | | | |
|------|-----------------|--------|------------|
| REV. | DESCRIPTION | Design | DATE |
| | INITIAL RELEASE | wada | 2012.05.11 |

NOTE:
 1.Q'TY: 10 pcs module /carton.
 2.Dimension: 530*295*230mm
 3.Weight: 7.0 Kg

| | | | |
|------|-----------------|-----|--------|
| | | | |
| 4 | CARTON | 1 | |
| 3 | 金屬袋 | 10 | 抗靜電 |
| 2 | 10.4" HB Module | 10 | |
| 1 | 瓦楞隔板緩衝材 | 1 | 上蓋+ 底座 |
| ITEM | DESCRIPTION | QTY | REMARK |

| | | | | | |
|-----------|-------------------|-----------|---------|------|---|
| MTL.SPEC. | UNSPECIFIED TOL'S | REMARK | | | |
| | ANGLE | | | | |
| | ROUGHNESS | | | | |
| APPROVE | Patrickl | '10.08.19 | SCALE | UNIT | SHEET |
| CHECK | Patrickl | '10.08.19 | | | 1 OF 1 |
| DRAWN | wada | '12.05.11 | MTL.NO. | | DWG FILE: |
| | | | | | DWG.TITLE PD104SLK Module Packing Draw |
| | | | | | REV. 01 A4 SIZE |