

To : \_\_\_\_\_

## Specification of FUJITSU TFT-LCD module

FLC56XWC8V

Approval

Date :

By :

This Product is designed, developed and manufactured as contemplated for general use, including without limitation, general office use, personal use, household use, and ordinary industrial use, but is not designed, developed and manufactured as contemplated for use accompanying fatal risks or dangers that, unless extremely high safety is secured, could lead directly to death, personal injury, severe physical damage or other loss (hereinafter "High Safety Required Use"), including without limitation, nuclear reaction control in nuclear facility, aircraft flight control, air traffic control, mass transport control, medical life support system, missile launch control in weapon system. If customer's product possibly falls under the category of High Safety Required Use, please consult with our sales representatives in charge before such use. In addition, FDTC shall not be liable against the customer and/or any third party for any claims or damages arising in connection with the High Safety Required Use of the Product without permission.

Specification No. : Tech Bes LCD-00175

Issue Date : May. 20. 2003

Issued by :

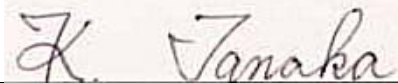

K. Tanaka  
Director  
Design Dept.  
Technology Div.

FUJITSU DISPLAY TECHNOLOGIES CORPORATION

1

2

3

4

【FLC56XWC8V】

# REVISION HISTORY

A

A

| Revision | Date      | Prepared | Checked  |  | Approved | Summary               |
|----------|-----------|----------|----------|--|----------|-----------------------|
| 01       | May/20/03 | Nagatani | Nagatani |  | K.Tanaka | 1 <sup>st</sup> issue |
|          |           |          |          |  |          |                       |
|          |           |          |          |  |          |                       |
|          |           |          |          |  |          |                       |
|          |           |          |          |  |          |                       |
|          |           |          |          |  |          |                       |
|          |           |          |          |  |          |                       |
|          |           |          |          |  |          |                       |
|          |           |          |          |  |          |                       |
|          |           |          |          |  |          |                       |

B

B

C

C

D

D

E

DATE DOCUMENT CONTROL SECTION

F

|      |          |          |       |          |                                 |            |        |  |
|------|----------|----------|-------|----------|---------------------------------|------------|--------|--|
|      |          |          |       |          |                                 | FLC56XWC8V |        |  |
| 03   | 20030526 | Nagatani |       | K.Tanaka | P12,19Revise,P28,29Total revise |            |        | CUST.                                    |
| 02   | 20030307 | Nagatani |       | K.Tanaka | Total revise                    |            |        |  |
| EDIT | DATE     | DESIG.   | CHECK | APPR.    | DESCRIPTION                     |            |        | FUJITSU DISPLAY TECHNOLOGIES CORPORATION |
|      |          |          |       |          |                                 |            | 1 / 29 |  |

1

# TABLE OF CONTENTS

A

1.APPLICATIONS ..... 3

2.PRODUCT NAME AND MODEL NAME

2-1.Product Name ..... 3

2-2.Model Name ..... 3

3.OVERVIEW ..... 3

4.CONFIGURATION..... 3

5.MECHANICAL SPECIFICATIONS ..... 4

B

6.ABSOLUTE MAXIMUM RATINGS ..... 5

7.RECOMMENDED OPERATING CONDITIONS..... 5

8.ELECTRICAL SPECIFICATIONS ..... 6

9.OPTICAL SPECIFICATIONS..... 8

10.INTERFACE SPECIFICATIONS

10-1.Signal descriptions ..... 12

10-2.Color Data Assignment ..... 15

10-3.Input Signal Timing ..... 16

C

10-4.Correspondence between Data and Display Position ..... 18

10-5.Power Supply Sequence ..... 18

11.BACKLIGHT SPECIFICATIONS

11-1.Pin Configuration for Backlight..... 19

11-2.CCFL ..... 20

11-3.Life..... 20

12.APPEARANCE SPECIFICATIONS

12-1.Appearance ..... 21

12-2.Dot defects ..... 21

D

13.ENVIRONMENTAL SPECIFICATIONS ..... 23

14.INDICATIONS ..... 24

15.PACKAGING ..... 24

16.WARRANTY ..... 25

17.PRECAUTIONS ..... 25

18. MISCELLANEOUS..... 27

OUTLINE DRAWING..... 28

A

B

C

D

E

DOCUMENT CONTROL SECTION

DATE

|        |      |        |       |       |             |  |  |        |     |
|--------|------|--------|-------|-------|-------------|--|--|--------|-----|
|        |      |        |       |       |             | FLC56XWC8V                               |  |        |     |
|        |      |        |       |       |             | Tech Bes LCD-00175                       |  | CUST.  |     |
| EDIT   | DATE | DESIG. | CHECK | APPR. | DESCRIPTION | FUJITSU DISPLAY TECHNOLOGIES CORPORATION |  | STATUS | 2 / |
| DESIG. |      |        | CHECK |       | APPR.       |  |  |        |     |

F

### 1. APPLICATIONS

This specification is applied to the 22.0 in. XGA-WIDE supported TFT-LCD module.

### 2. PRODUCT NAME AND MODEL NAME

2-1. Product Name : LCD Module

2-2. Model Name : FLC56XWC8V

### 3. OVERVIEW

This LCD module has a TFT active matrix type liquid crystal panel 1280×768 pixels, and diagonal size of 56cm (22.0-inch). This LCD has a LVDS interface and can display 16,777,216 colors.

The power supply of this LCD module is +12V DC single.

This module has the characteristics for applying TCO'99.

### 4. CONFIGURATION

This LCD module consists of a color TFT-LCD panel that is mounted with TFT driver ICs, a cold-cathode fluorescent tube back-light.

The inverter for the backlight is included.

Figure 4-1 shows a block diagram of this LCD module.

DOCUMENT CONTROL SECTION

DATE

|        |      |        |       |       |             |  |  |
|--------|------|--------|-------|-------|-------------|--|--|
|        |      |        |       |       |             | FLC56XWC8V                               |  |
|        |      |        |       |       |             | Tech Bes LCD-00175                       |  |
|        |      |        |       |       |             | CUST.                                    |  |
| EDIT   | DATE | DESIG. | CHECK | APPR. | DESCRIPTION | FUJITSU DISPLAY TECHNOLOGIES CORPORATION |  |
| DESIG. |      |        | CHECK |       | APPR.       | 3 /                                      |  |

A

A

B

B

C

C

D

D

E

F

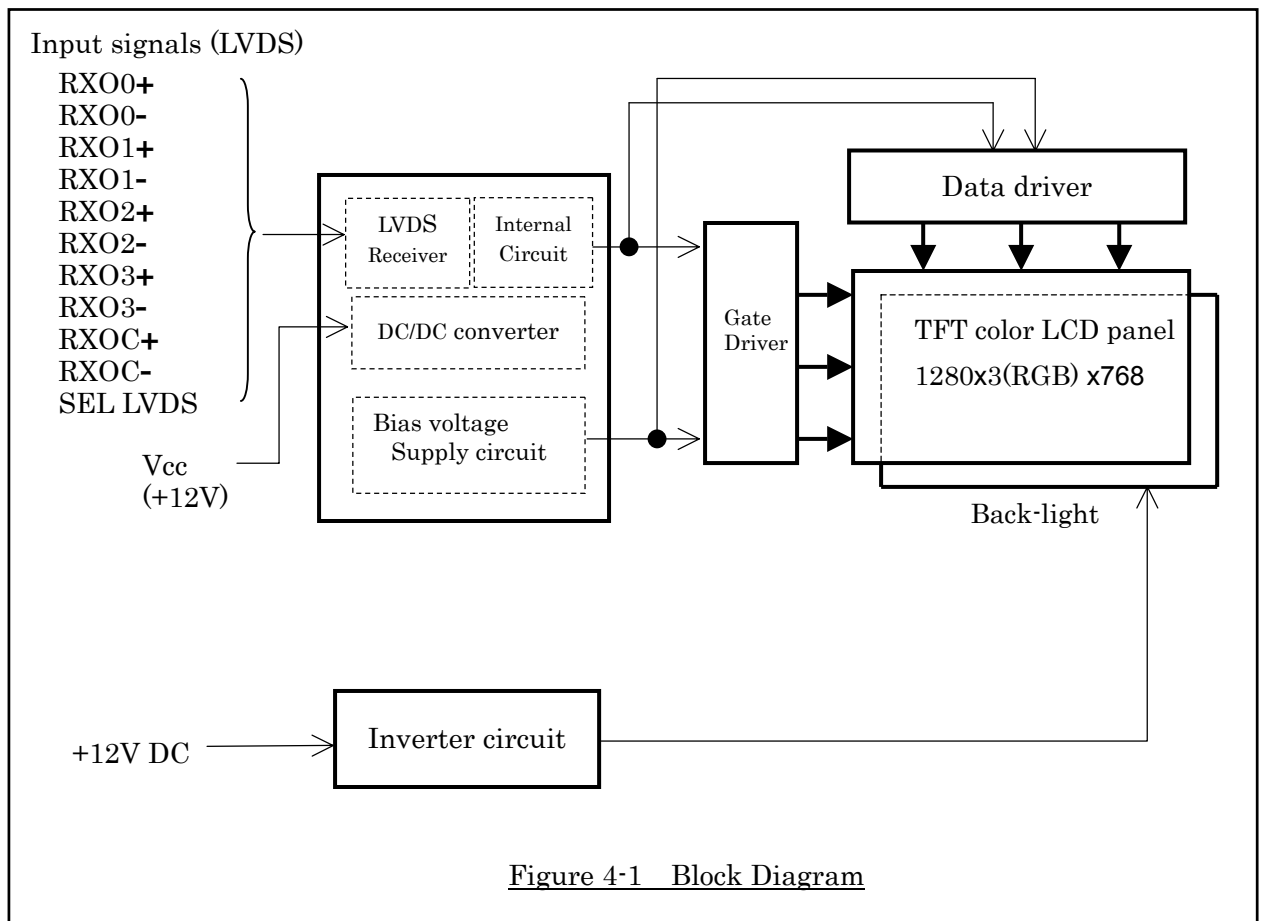

Figure 4-1 Block Diagram

### 5. MECHANICAL SPECIFICATIONS

Table 5-1 shows the mechanical specifications of this LCD module.

Table 5-1. Mechanical Specifications

| Item               | Specifications                                  | Unit | Remark   |
|--------------------|---|------|--|
| Dimensions         | 508.0×316.0×33.8 (Typ.)<br>(Exclude a inverter) | mm   | *Direct lighting type backlight is used.<br>*Include a inverter.<br>*Inverter area thickness is (Typ.40.4mm)<br>*For details on dimensions, See dimensional outline drawing. (At page 32 to 33 Fig.19-1,2,3) |
| Display Resolution | (1280×3) ×768                                   | —    |  |
| Display Dot Area   | 480.0×288.0                                     | mm   |  |
| Dot Pitch          | (0.125×3) ×0.375                                | mm   |  |
| Aspect Ratio       | 1 : 1   | —    |  |
| Weight             | 2,700 max                                       | g    |  |
| FG-SG              | Short circuit                                   | —    |  |

DOCUMENT CONTROL SECTION

DATE

|        |      |        |       |       |             |  |  |
|--------|------|--------|-------|-------|-------------|--|--|
|        |      |        |       |       |             | FLC56XWC8V                               |  |
|        |      |        |       |       |             | Tech Bes LCD-00175                       |  |
|        |      |        |       |       |             | CUST.                                    |  |
| EDIT   | DATE | DESIG. | CHECK | APPR. | DESCRIPTION | FUJITSU DISPLAY TECHNOLOGIES CORPORATION |  |
| DESIG. |      |        | CHECK |       | APPR.       | 4 /                                      |  |

### 6. ABSOLUTE MAXIMUM RATINGS

Table 6-1 shows the absolute maximum rating of this LCD module.

Table 6-1. Absolute Maximum Ratings

| Item                       | Symbol           | Condition | MIN. | TYP. | MAX.             | Unit |
|----------------------------|------------------|-----------|------|------|------------------|------|
| Supply Voltage             | V <sub>CC</sub>  | Ta=25°C   | -0.3 | —    | 14.0             | V    |
|                            | V <sub>INV</sub> | Ta=25°C   | -0.3 | —    | 14.0             | V    |
| Input Signal Voltage       | V <sub>IN</sub>  | Ta=25°C   | -0.3 | —    | 3.6              | V    |
| Control Voltage            | V <sub>CNT</sub> | Ta=25°C   | -0.3 | —    | V <sub>INV</sub> | V    |
| Brightness Control Voltage | V <sub>VR4</sub> | Ta=25°C   | 0    | —    | 4.0              | V    |

### 7. RECOMMENDED OPERATING CONDITIONS

Table 7-1 shows the recommended operating conditions of this LCD module.

Table 7-1. Recommended Operating Conditions

| Item                      | Symbol           | MIN.            | TYP. | MAX. | Unit     |
|---------------------------|------------------|-----------------|------|------|----------|
| Supply Voltage (Logic)    | V <sub>CC</sub>  | 11.5            | 12.0 | 12.5 | V        |
| Supply Voltage (Inverter) | V <sub>INV</sub> | 10.8            | 12.0 | 13.2 | V        |
| Ripple Voltage            | V <sub>CC</sub>  | V <sub>RP</sub> | —    | —    | 0.1<br>V |

DOCUMENT CONTROL SECTION

DATE

|        |      |        |       |       |             |  |  |  |  |                    |  |       |
|--------|------|--------|-------|-------|-------------|--|--|--|--|--------------------|--|-------|
|        |      |        |       |       |             |  |  |  |  | FLC56XWC8V         |  |       |
|        |      |        |       |       |             |  |  |  |  | Tech Bes LCD-00175 |  | CUST. |
| EDIT   | DATE | DESIG. | CHECK | APPR. | DESCRIPTION |  |  |  | FUJITSU DISPLAY TECHNOLOGIES CORPORATION |                    |  | 5 /   |
| DESIG. |      |        |       |       |             |  |  |  |  |                    |  |       |

**8. ELECTRICAL SPECIFICATIONS**

Table 8-1 shows the electrical specifications of this LCD module.

A

A

| Item                                     | Symbol                     | Condition  | MIN.  | TYP.  | MAX.             | Unit  | Remark |     |    |
|--|----------------------------|--|---|-------|------------------|-------|--------|-----|----|
| Differential-input Voltage (High)        | V <sub>IH</sub>            | V <sub>CM</sub> =+1.2V   | —   | —     | 100              | mV    |        |     |    |
| Differential-input Voltage (Low)         | V <sub>IL</sub>            |  | -100  | —     | —                | MV    |        |     |    |
| Supply Current                           | I <sub>CC</sub>            | V <sub>CC</sub> =+12.0±0.5V<br>V <sub>SS</sub> =0V<br>DCLK=65MHz<br>60Hz | —   | (610) | (1200)           | mA    | *1     |     |    |
| Supply Rush Current                      | I <sub>SCC</sub>           |  | —   | —     | (4.7)            | A     | *2     |     |    |
| Supply Rush Current Duration (1A excess) | T <sub>SCC</sub>           |  | —   | —     | (0.2)            | ms    |        |     |    |
| BACK LIGHT (*3)                          | Supply Current             | I <sub>INV</sub>   | V <sub>INV</sub> =12.0V<br>V <sub>VR</sub> =0V  |       | —                | (4.3) | T.B.D  | A   | *3 |
|  | Brightness Control Voltage | V <sub>VR</sub>  | 0   | —     | 3.5              | V     |        |     |    |
|  | Lighting Frequency         | f  | V <sub>INV</sub> =12.0V,<br>V <sub>VR</sub> =0V |       | —                | T.B.D | —      | KHz |    |
|  | Lighting Fix Voltage       | V <sub>ent</sub>   | 0   | —     | (0.8)            | V     |        |     |    |
|  | Non-Lighting Fix Voltage   | V <sub>ent</sub>   | (2.1)   | —     | V <sub>INV</sub> |       |        |     |    |

B

B

C

C

(\*1) Typical current situation : vertical gray scale V<sub>CC</sub>=12.0V  
Maximum current situation: pixel vertical line pattern. V<sub>CC</sub>=11.5V  
Without rush current.

(\*2) These items prescribe the rush current for starting internal DC/DC.  
Charging current to capacitors of V<sub>CC</sub> is not prescribed.

(\*3) External power supply for inverter shall have the current capacity more than (16)A of the supply current (I<sub>INV</sub>), otherwise the protective circuit of inverter (fuse) might not work.

D

D

DOCUMENT CONTROL SECTION

DATE

E

F

|        |      |        |       |       |             |                    |  |
|--------|------|--------|-------|-------|-------------|--------------------|--|
|        |      |        |       |       |             | FLC56XWC8V         |  |
|        |      |        |       |       |             | Tech Bes LCD-00175 |  |
|        |      |        |       |       |             | CUST.              |  |
| EDIT   | DATE | DESIG. | CHECK | APPR. | DESCRIPTION |                    | FUJITSU DISPLAY TECHNOLOGIES CORPORATION |
| DESIG. |      |        | CHECK |       | APPR.       |                    | 6 /                                      |

Note1) Measurement circuit is based on Fig.8-1.

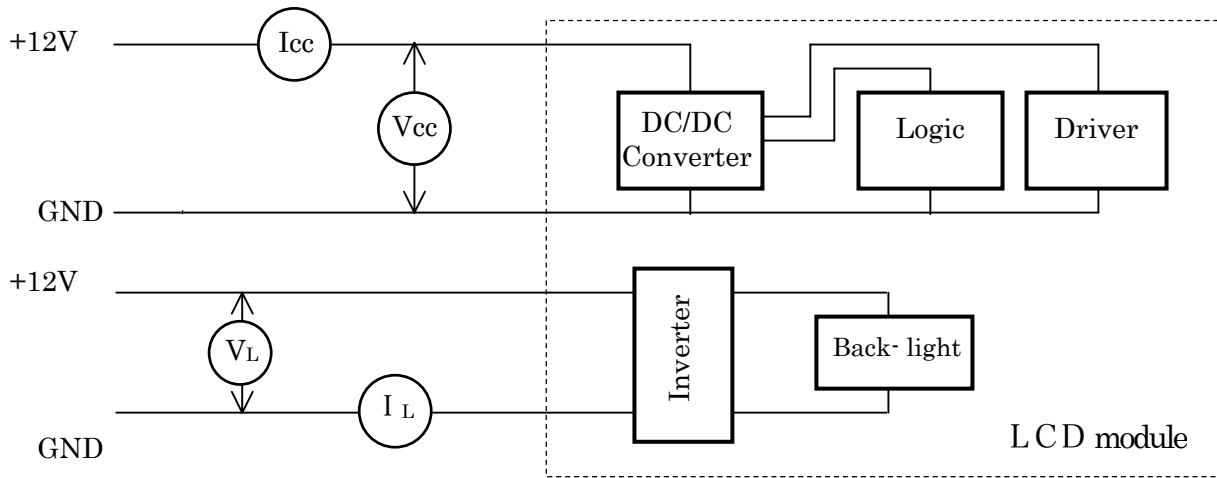

Fig.8-1. Measurement Circuit

Note 2) Equivalent Circuit is based on Fig.8-2 (a), (b).

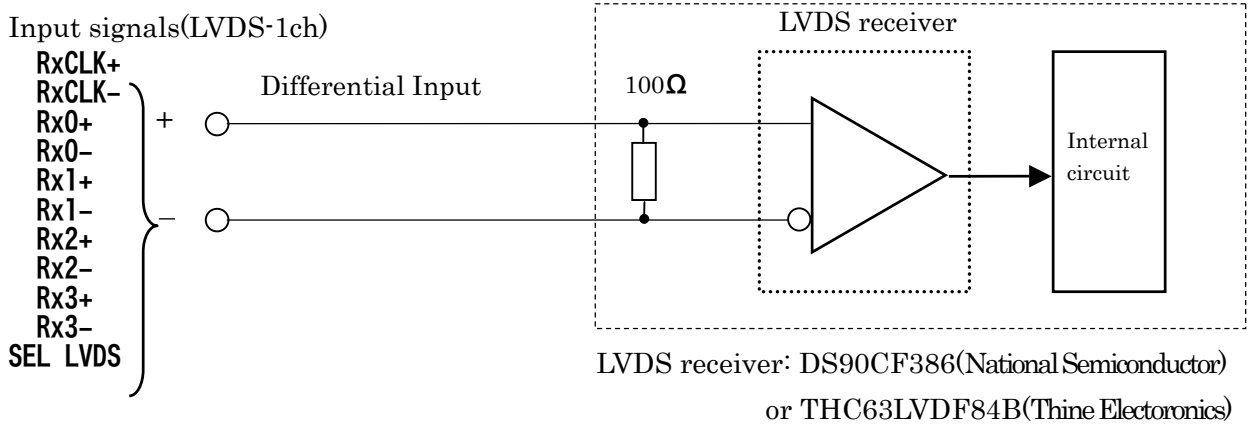
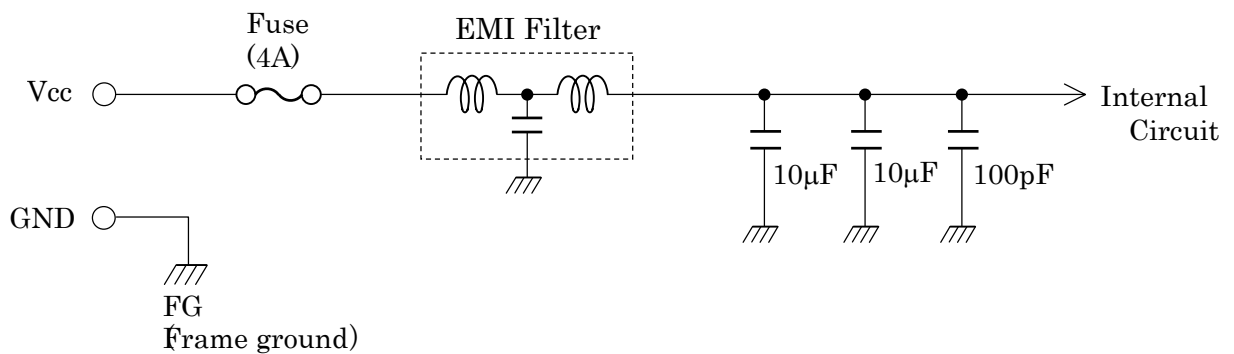

Fig.8-2 (a) Equivalent Circuit of Logic Signal Input



Fuse: KAB240240-4A (Matsuo Electric Co. LTD)  
EMI Filter: SGM45C1H222 (Sumitomo Metal Electronics Devices Inc)

Fig.8-2 (b) Equivalent Circuit of Power Supply

DOCUMENT CONTROL SECTION

DATE

|        |      |        |       |       |             |  |  |
|--------|------|--------|-------|-------|-------------|--|--|
|        |      |        |       |       |             | FLC56XWC8V                               |  |
|        |      |        |       |       |             | Tech Bes LCD-00175                       |  |
|        |      |        |       |       |             | CUST.                                    |  |
| EDIT   | DATE | DESIG. | CHECK | APPR. | DESCRIPTION | FUJITSU DISPLAY TECHNOLOGIES CORPORATION |  |
| DESIG. |      |        | CHECK |       | APPR.       | 7 /                                      |  |



**9. OPTICAL SPECIFICATIONS**

Table 9-1 shows the optical specifications of this LCD module.

Table 9-1. Optical Specifications

Ta=25°C

| Item                                       | Symbol        | Condition                  | Specifications   |   |       | Unit  | Remark            |                          |                  |            |
|--|---------------|----------------------------|--|---|-------|-------|-------------------|--------------------------|------------------|------------|
|  |               |                            | MIN.   | TYP.                                    | MAX.  |       |                   | Note                     |                  |            |
| Visual Angle                               | Horizontal    | $\theta_{L,R}$             | CR $\geq$ 10   | $\theta_{U,D}=0^\circ$                  | 85    | —     | —                 | deg                      | (1)(2)           |            |
|  | Vertical      | $\theta_{U,D}$             |  | $\theta_{L,R}=0^\circ$                  | 85    | —     | —                 | deg                      | (3)(5)           |            |
|  | All Direction | $\theta$                   |  |   | —     | 80    | —                 | deg                      | (6)              |            |
| Contrast Ratio                             | CR            | $\theta_{L,R,U,D}=0^\circ$ |  | (400)                                   | 600   | —     | —                 | White/Black              | (1)(2)<br>(3)(5) |            |
| Response Time (ON) (B→W)                   | $t_{on}$      | $\theta_{L,R,U,D}=0^\circ$ | Ta=25°C  | —                                       | 15    | 30    | ms                |                          | (1)              |            |
|  |               |                            | Ta=0°C   | —                                       | 50    | 100   | ms                |                          |                  | (4)        |
| Response Time (OFF) (W→B)                  | $t_{off}$     | $\theta_{L,R,U,D}=0^\circ$ | Ta=25°C  | —                                       | 10    | 25    | ms                |                          | (5)              |            |
|  |               |                            | Ta=0°C   | —                                       | 50    | 100   | ms                |                          |                  |            |
| Response Time (ON or OFF) (All gray scale) | $t_{avg}$     | $\theta_{L,R,U,D}=0^\circ$ | Ta=25°C<br>60±3Hz  | —                                       | 15    | —     | ms                | Average of Response Time |                  |            |
| Brightness                                 | I             | $\theta_{L,R,U,D}=0^\circ$ | V <sub>CC</sub> =12.0V<br>V <sub>INV</sub> =12.0V<br>(At maximum Brightness) | 400                                     | 500   |       | cd/m <sup>2</sup> | White *1                 | (1)(5)           |            |
| Brightness Uniformity                      | $\Delta I$    |                            |  | 70                                      | —     | —     | %                 |                          | (1)(5)<br>(7)    |            |
| Chromaticity                               | W             | x                          |  | 0.253                                   | 0.283 | 0.313 | —                 |                          |                  | (1)<br>(5) |
|  |               | y                          |  | 0.267                                   | 0.297 | 0.327 | —                 |                          |                  |            |
|  | R<br>G<br>B   | (x, y)                     | Red  | (x=0.637 y=0.353) Typ.                  |       |       |                   |                          |                  |            |
|  |               | Green                      | (x=0.287 y=0.598) Typ.   |   |       |       |                   |                          |                  |            |
|  |               | Blue                       | (x=0.142 y=0.075) Typ.   |   |       |       |                   |                          |                  |            |
| LCD Panel Type                             |               |                            |  | TFT Color                               |       |       |                   |                          |                  |            |
| Display Mode                               |               |                            |  | Normally Black                          |       |       |                   |                          |                  |            |
| Wide Viewing Angle Technology              |               |                            |  | MVA-Premium                             |       |       |                   |                          |                  |            |
| Optimum Viewing Angle                      |               |                            |  | — (Symmetry)                            |       |       |                   |                          | (6)              |            |
| Display Color                              |               |                            |  | 16,777,216 (8-bit color)                |       |       |                   |                          |                  |            |
| Color of non-display area                  |               |                            |  | Black                                   |       |       |                   |                          |                  |            |
| Surface Treatment                          |               |                            |  | Clear , Hard coating,<br>Low reflection |       |       |                   |                          |                  |            |

(\*1) Specified value is measured in 20~30 minutes after lighting on (The simplical module , Center point).

A required value may not be achieved on condition that LCD module is built in the cabinet because of its radiation.

(Note1) •CS-1000 (MINOLTA Co., Ltd.) , BM-5A(Topcon) or equivalent luminance colorimeter should be used for the measurement. Field=2°, L=500mm

•The specified value of viewing angle, contrast, brightness, brightness uniformity and chromaticity are under the dark room condition (1lux or less).

DOCUMENT CONTROL SECTION

DATE

FLC56XWC8V

Tech Bes LCD-00175

CUST.

|        |      |        |       |       |             |  |     |
|--------|------|--------|-------|-------|-------------|--|-----|
| EDIT   | DATE | DESIG. | CHECK | APPR. | DESCRIPTION | FUJITSU DISPLAY TECHNOLOGIES CORPORATION | 8 / |
| DESIG. |      |        | CHECK |       | APPR.       |  |     |

Note 1) Definition of Viewing Angle (1)

Based on Fig.9-2.

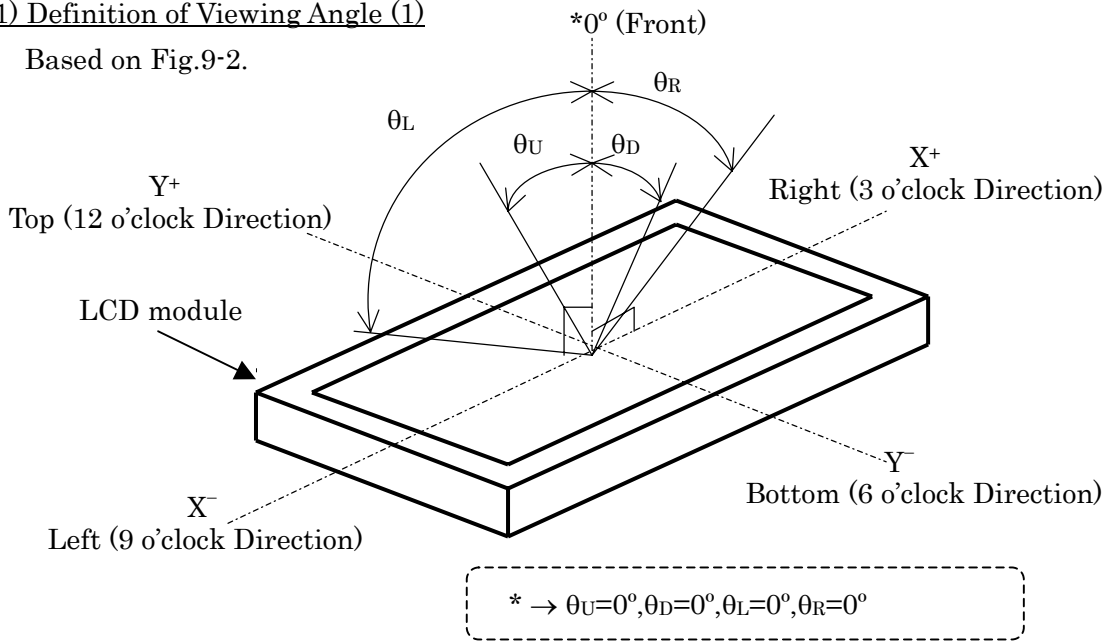

Fig.9-2. Definition of Viewing Angle (1)

Note 2) Definition of Viewing Angle (2)

Based on Fig.9-3.

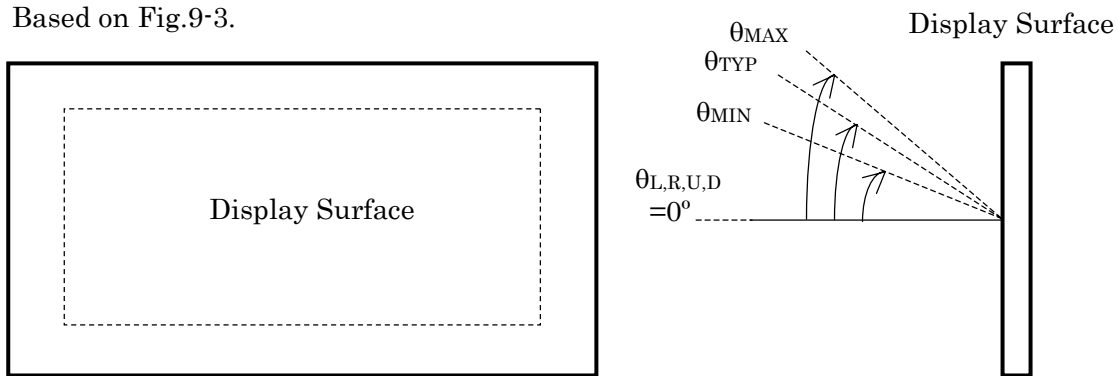

Fig.9-3. Definition of Viewing Angle (2)

Note 3) Definition of Contrast Ratio (CR)

Determined by Formula (1) based on Fig.9-4. Voltage-Brightness Characteristics.

$$= \frac{L_W \text{ (Brightness at white)}}{L_B \text{ (Brightness at black)}} \quad \text{----- (1)}$$

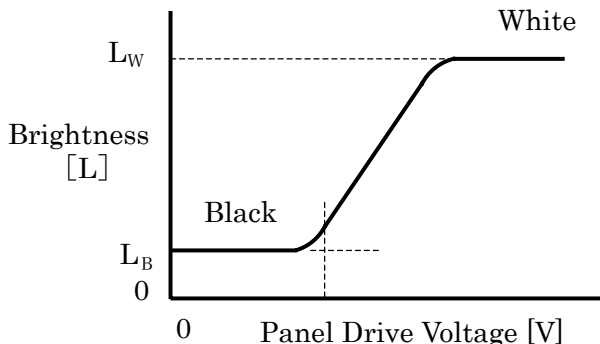

Fig.9-4. Voltage-Brightness Characteristics

|                          |  |
|--------------------------|--|
| DOCUMENT CONTROL SECTION |  |
|                          |  |
| DATE                     |  |

|        |      |        |       |       |             |  |     |
|--------|------|--------|-------|-------|-------------|--|-----|
|        |      |        |       |       |             | FLC56XWC8V                               |     |
|        |      |        |       |       |             | Tech Bes LCD-00175                       |     |
|        |      |        |       |       |             | CUST.                                    |     |
| EDIT   | DATE | DESIG. | CHECK | APPR. | DESCRIPTION | FUJITSU DISPLAY TECHNOLOGIES CORPORATION |     |
| DESIG. |      |        | CHECK |       | APPR.       |  | 9 / |

Note 4) Definition of Response Time

Based on Fig.9-5.

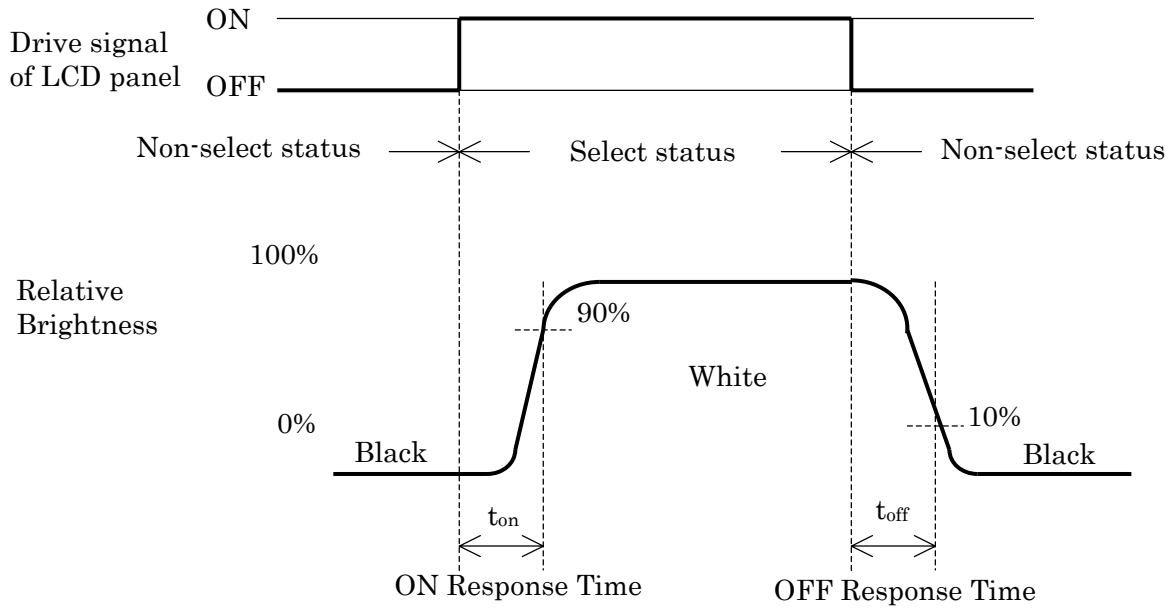

Fig.9-5. Definition of Response Time

Note 5) Contrast Ratio and Response Measurement System

Based on Fig.9-6.

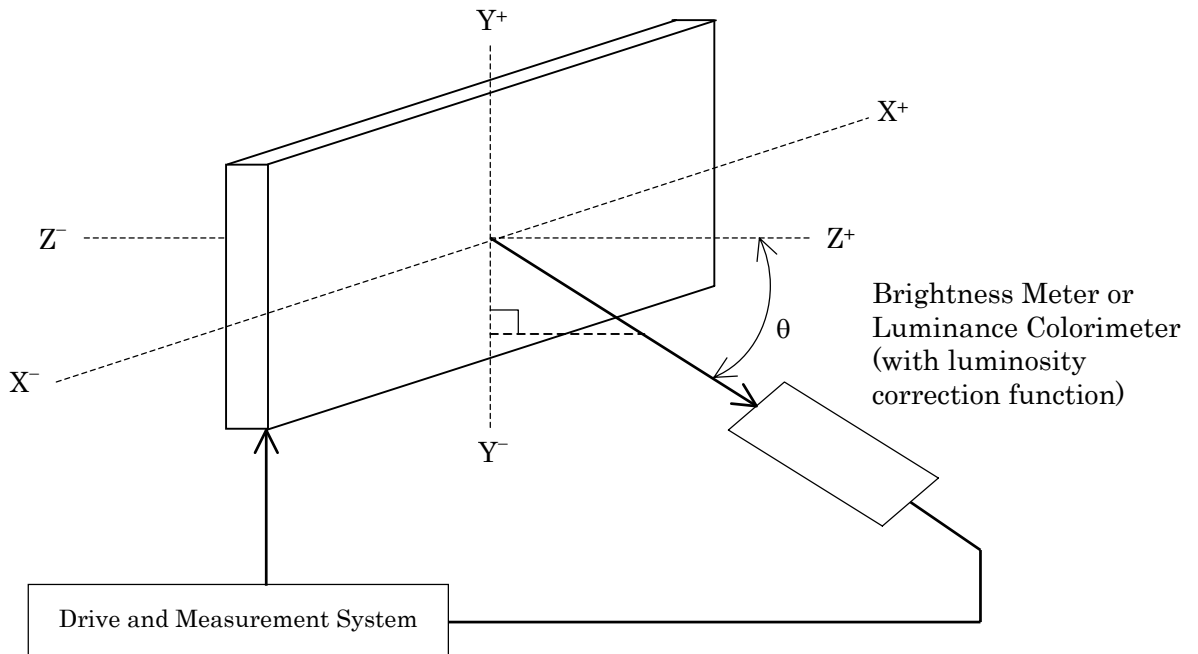

Fig.9-6. Contrast Ratio and Response Time Measurement System

|      |                          |
|------|--------------------------|
| DATE | DOCUMENT CONTROL SECTION |
|      |                          |

|        |      |        |       |       |             |  |     |
|--------|------|--------|-------|-------|-------------|--|-----|
|        |      |        |       |       |             | FLC56XWC8V                               |     |
|        |      |        |       |       |             | Tech Bes LCD-00175                       |     |
|        |      |        |       |       |             | FUJITSU DISPLAY TECHNOLOGIES CORPORATION |     |
| EDIT   | DATE | DESIG. | CHECK | APPR. | DESCRIPTION | STATUS                                   | 10/ |
| DESIG. |      |        | CHECK |       | APPR.       |  |     |

Note 6) Definition of Optimum Viewing Angle

Based on Fig.9-7.

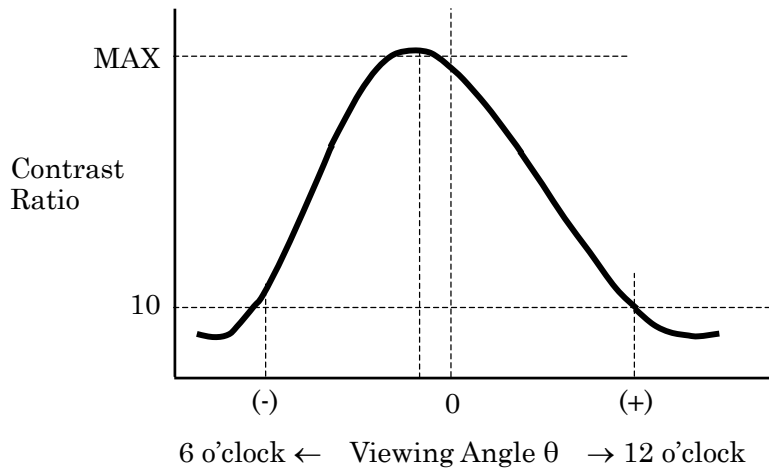

Fig.9-7. Definition of Viewing Angle

Note 7) Definition of Brightness Uniformity

Brightness uniformity is defined by the following formula.

Brightness (I1~I9) are measured at the following 9 points ( ① ~ ⑨ ) on the display area shown in Fig.9-8.

$$\text{Brightness Uniformity } (\Delta L) = \frac{|\text{Min. In}|}{|\text{Max. In}|} \times 100 (\%), n=1 \text{ to } 9$$

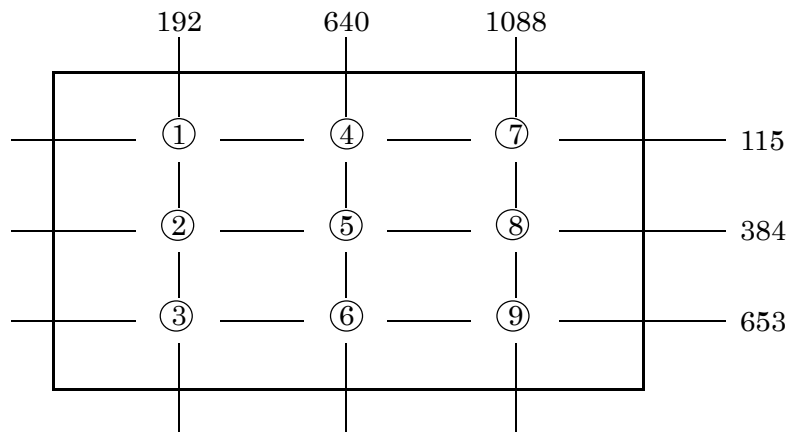

Note) Each measurement point ( ① ~ ⑨ ) defines the center spot of Brightness Meter view. The tolerance of measurement position is  $\pm 3\text{mm}$ .

Fig.9-8. Measurement Points

DOCUMENT CONTROL SECTION

DATE

|        |      |        |       |       |  |                    |  |
|--------|------|--------|-------|-------|--|--------------------|--|
|        |      |        |       |       |  | FLC56XWC8V         |  |
|        |      |        |       |       |  | Tech Bes LCD-00175 |  |
|        |      |        |       |       |  | CUST.              |  |
| EDIT   | DATE | DESIG. | CHECK | APPR. | DESCRIPTION                              |                    |  |
| DESIG. |      |        | CHECK |       | FUJITSU DISPLAY TECHNOLOGIES CORPORATION |                    |  |
|        |      |        |       |       |  | 11/                |  |

## 10. INTERFACE SPECIFICATIONS

### 10-1-1. Signal descriptions

Table 10-1 shows the description and configuration of Interface signals (CN1).

Table 10-1-1. Interface signals (CN1)

| Pin No. | Symbol   | I/O | Function  |
|---------|----------|-----|---|
| 1       | VDD      | —   | +12V Power supply   |
| 2       | VDD      | —   | +12V Power supply   |
| 3       | GND      | —   | Ground  |
| 4       | GND      | —   | Ground  |
| 5       | RX0-     | I   | LVDS Receiver Signal(-)   |
| 6       | RX0+     | I   | LVDS Receiver Signal(+)   |
| 7       | GND      | —   | Ground  |
| 8       | RX1-     | I   | LVDS Receiver Signal(-)   |
| 9       | RX1+     | I   | LVDS Receiver Signal(+)   |
| 10      | GND      | —   | Ground  |
| 11      | RX2-     | I   | LVDS Receiver Signal(-)   |
| 12      | RX2+     | I   | LVDS Receiver Signal(+)   |
| 13      | GND      | —   | Ground  |
| 14      | RXCLK-   | I   | LVDS Receiver Clock Signal(-)   |
| 15      | RXCLK+   | I   | LVDS Receiver Clock Signal(+)   |
| 16      | GND      | —   | Ground  |
| 17      | RX3-     | I   | LVDS Receiver Signal(-)   |
| 18      | RX3+     | I   | LVDS Receiver Signal(+)   |
| 19      | GND      | —   | Ground  |
| 20      | SEL LVDS | I   | Select LVDS data order<br>Hi : table 10-1-2<br>Open or Low : table 10-1-3 |

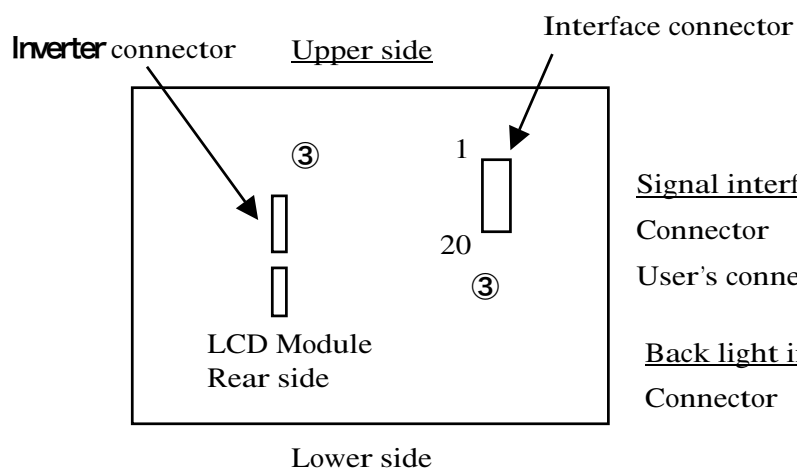

#### Signal interface

Connector : D14H-20P-1.25H(HIROSE)

User's connector : DF14-20S-1.25 (HIROSE)

#### Back light interface ③

Connector : S10B-PH-SM3-TB (JST)

S6B-PH-SM3-TB (JST)

User's connector : PHR-12(JST)

PHR-6(JST)

DOCUMENT CONTROL SECTION

DATE

FLC56XWC8V

Tech Bes LCD-00175

CUST.

03 20030526

Correct Fig.,Connector

EDIT

DATE

DESIG.

CHECK

APPR.

CHECK

APPR.

DESCRIPTION

APPR.

FUJITSU DISPLAY TECHNOLOGIES CORPORATION

Sheet

12 /

10-1-2. LVDS Data Mapping 1

Table 10-1-2 shows the LVDS data mapping 1.(SEL LVDS = High)

Table 10-1-2. LVDS Data Mapping 1

| Transmitter (DS90CF386) |         | Symbol   | Interface connector    |          |                  | Receiver (DS90CF386) |          | LCD Control input |
|-------------------------|---------|----------|------------------------|----------|------------------|----------------------|----------|-------------------|
| Pin                     | INPUT   |          | Systemside             | Pin      | LCD module       | Pin                  | OUTPUT   |                   |
| 51                      | TxIN0   | R0       | TxOUT0-<br>TxOUT0+     | 5<br>6   | RX0-<br>RX0+     | 27                   | RxOUT0   | R0                |
| 52                      | TxIN1   | R1       |                        |          |                  | 29                   | RxOUT1   | R1                |
| 54                      | TxIN2   | R2       |                        |          |                  | 30                   | RxOUT2   | R2                |
| 55                      | TxIN3   | R3       |                        |          |                  | 32                   | RxOUT3   | R3                |
| 56                      | TxIN4   | R4       |                        |          |                  | 33                   | RxOUT4   | R4                |
| 2                       | TxIN5   | R7       | TxOUT3-<br>TxOUT3+     | 17<br>18 | RX3-<br>RX3+     | 34                   | RxOUT5   | R7                |
| 3                       | TxIN6   | R5       | TxOUT0-<br>TxOUT0+     | 5<br>6   | RX0-<br>RX0+     | 35                   | RxOUT6   | R5                |
| 4                       | TxIN7   | G0       |                        |          |                  | 37                   | RxOUT7   | G0                |
| 6                       | TxIN8   | G1       | TxOUT1-<br>TxOUT1+     | 8<br>9   | RX1-<br>RX1+     | 38                   | RxOUT8   | G1                |
| 7                       | TxIN9   | G2       | TxOUT1-<br>TxOUT1+     | 8<br>9   | RX1-<br>RX1+     | 39                   | RxOUT9   | G2                |
| 8                       | TxIN10  | G6       | TxOUT3-<br>TxOUT3+     | 17<br>18 | RX3-<br>RX3+     | 41                   | RxOUT10  | G6                |
| 10                      | TxIN11  | G7       |                        |          |                  | 42                   | RxOUT11  | G7                |
| 11                      | TxIN12  | G3       | TxOUT1-<br>TxOUT1+     | 8<br>9   | RX1-<br>RX1+     | 43                   | RxOUT12  | G3                |
| 12                      | TxIN13  | G4       |                        |          |                  | 45                   | RxOUT13  | G4                |
| 14                      | TxIN14  | G5       |                        |          |                  | 46                   | RxOUT14  | G5                |
| 15                      | TxIN15  | B0       | TxOUT3-<br>TxOUT3+     | 17<br>18 | RX3-<br>RX3+     | 47                   | RxOUT15  | B0                |
| 16                      | TxIN16  | B6       |                        |          |                  | 49                   | RxOUT16  | B6                |
| 18                      | TxIN17  | B7       | TxOUT3-<br>TxOUT3+     | 17<br>18 | RX3-<br>RX3+     | 50                   | RxOUT17  | B7                |
| 19                      | TxIN18  | B1       | TxOUT1-<br>TxOUT1+     | 8<br>9   | RX1-<br>RX1+     | 51                   | RxOUT18  | B1                |
| 20                      | TxIN19  | B2       | TxOUT2-<br>TxOUT2+     | 11<br>12 | RX2-<br>RX2+     | 53                   | RxOUT19  | B2                |
| 22                      | TxIN20  | B3       |                        |          |                  | 54                   | RxOUT20  | B3                |
| 23                      | TxIN21  | B4       |                        |          |                  | 55                   | RxOUT21  | B4                |
| 24                      | TxIN22  | B5       |                        |          |                  | 1                    | RxOUT22  | B5                |
| 25                      | TxIN23  | RESERVED | TxOUT3-<br>TxOUT3+     | 17<br>18 | RX3-<br>RX3+     | 2                    | RxOUT23  | Not use           |
| 27                      | TxIN24  | RESERVED | TxOUT2-<br>TxOUT2+     | 11<br>12 | RX2-<br>RX2+     | 3                    | RxOUT24  | Not use           |
| 28                      | TxIN25  | RESERVED |                        |          |                  | 5                    | RxOUT25  | Not use           |
| 30                      | TxIN26  | ENAB     |                        |          |                  | 6                    | RxOUT26  | ENAB              |
| 50                      | TxIN27  | R6       | TxOUT3-<br>TxOUT3+     | 17<br>18 | RX3-<br>RX3+     | 7                    | RxOUT27  | R6                |
| 31                      | TxCLKIN | DCLK     | TxCLKOUT-<br>TxCLKOUT+ | 14<br>15 | RXCLK-<br>RXCLK+ | 26                   | RxCLKOUT | DCLK              |

DOCUMENT CONTROL SECTION

DATE

|        |      |        |       |       |  |                    |  |
|--------|------|--------|-------|-------|--|--------------------|--|
|        |      |        |       |       |  | FLC56XWC8V         |  |
|        |      |        |       |       |  | Tech Bes LCD-00175 |  |
|        |      |        |       |       |  | CUST.              |  |
| EDIT   | DATE | DESIG. | CHECK | APPR. | DESCRIPTION                              |                    |  |
| DESIG. |      |        | CHECK |       | FUJITSU DISPLAY TECHNOLOGIES CORPORATION |                    |  |
|        |      |        |       |       |  | 13 /               |  |

10-1-3. LVDS Data Mapping 2

Table 10-1-3 shows the LVDS data mapping 2.(SEL LVDS = Open or Low)

Table 10-1-3. LVDS Data Mapping 2

| Transmitter (DS90CF385) |         | Symbol   | Interface connector    |          |                  | Receiver (DS90CF386) |          | LCD Control input |
|-------------------------|---------|----------|------------------------|----------|------------------|----------------------|----------|-------------------|
| Pin                     | INPUT   |          | System side            | Pin      | LCD module       | Pin                  | OUTPUT   |                   |
| 51                      | TxIN0   | R2       | TxOUT0-<br>TxOUT0+     | 5<br>6   | RX0-<br>RX0+     | 27                   | RxOUT0   | R2                |
| 52                      | TxIN1   | R3       |                        |          |                  | 29                   | RxOUT1   | R3                |
| 54                      | TxIN2   | R4       |                        |          |                  | 30                   | RxOUT2   | R4                |
| 55                      | TxIN3   | R5       |                        |          |                  | 32                   | RxOUT3   | R5                |
| 56                      | TxIN4   | R6       |                        |          |                  | 33                   | RxOUT4   | R6                |
| 2                       | TxIN5   | R1       | TxOUT3-<br>TxOUT3+     | 17<br>18 | RX3-<br>RX3+     | 34                   | RxOUT5   | R1                |
| 3                       | TxIN6   | R7       | TxOUT0-<br>TxOUT0+     | 5<br>6   | RX0-<br>RX0+     | 35                   | RxOUT6   | R7                |
| 4                       | TxIN7   | G2       |                        |          |                  | 37                   | RxOUT7   | G2                |
| 6                       | TxIN8   | G3       | TxOUT1-<br>TxOUT1+     | 8<br>9   | RX1-<br>RX1+     | 38                   | RxOUT8   | G3                |
| 7                       | TxIN9   | G4       | TxOUT1-<br>TxOUT1+     | 8<br>9   | RX1-<br>RX1+     | 39                   | RxOUT9   | G4                |
| 8                       | TxIN10  | G0       | TxOUT3-<br>TxOUT3+     | 17<br>18 | RX3-<br>RX3+     | 41                   | RxOUT10  | G0                |
| 10                      | TxIN11  | G1       |                        |          |                  | 42                   | RxOUT11  | G1                |
| 11                      | TxIN12  | G5       | TxOUT1-<br>TxOUT1+     | 8<br>9   | RX1-<br>RX1+     | 43                   | RxOUT12  | G5                |
| 12                      | TxIN13  | G6       |                        |          |                  | 45                   | RxOUT13  | G6                |
| 14                      | TxIN14  | G7       |                        |          |                  | 46                   | RxOUT14  | G7                |
| 15                      | TxIN15  | B2       |                        |          |                  | 47                   | RxOUT15  | B2                |
| 16                      | TxIN16  | B0       | TxOUT3-<br>TxOUT3+     | 17<br>18 | RX3-<br>RX3+     | 49                   | RxOUT16  | B0                |
| 18                      | TxIN17  | B1       | TxOUT3-<br>TxOUT3+     | 17<br>18 | RX3-<br>RX3+     | 50                   | RxOUT17  | B1                |
| 19                      | TxIN18  | B3       | TxOUT1-<br>TxOUT1+     | 8<br>9   | RX1-<br>RX1+     | 51                   | RxOUT18  | B3                |
| 20                      | TxIN19  | B4       | TxOUT2-<br>TxOUT2+     | 11<br>12 | RX2-<br>RX2+     | 53                   | RxOUT19  | B4                |
| 22                      | TxIN20  | B5       |                        |          |                  | 54                   | RxOUT20  | B5                |
| 23                      | TxIN21  | B6       |                        |          |                  | 55                   | RxOUT21  | B6                |
| 24                      | TxIN22  | B7       |                        |          |                  | 1                    | RxOUT22  | B7                |
| 25                      | TxIN23  | RESERVED | TxOUT3-<br>TxOUT3+     | 17<br>18 | RX3-<br>RX3+     | 2                    | RxOUT23  | Not use           |
| 27                      | TxIN24  | RESERVED | TxOUT2-<br>TxOUT2+     | 11<br>12 | RX2-<br>RX2+     | 3                    | RxOUT24  | Not use           |
| 28                      | TxIN25  | RESERVED |                        |          |                  | 5                    | RxOUT25  | Not use           |
| 30                      | TxIN26  | ENAB     |                        |          |                  | 6                    | RxOUT26  | ENAB              |
| 50                      | TxIN27  | R0       | TxOUT3-<br>TxOUT3+     | 17<br>18 | RX3-<br>RX3+     | 7                    | RxOUT27  | R0                |
| 31                      | TxCLKIN | DCLK     | TxCLKOUT-<br>TxCLKOUT+ | 14<br>15 | RXCLK-<br>RXCLK+ | 26                   | RxCLKOUT | DCLK              |

DOCUMENT CONTROL SECTION

DATE

|        |      |        |       |       |             |                    |  |       |      |
|--------|------|--------|-------|-------|-------------|--------------------|--|-------|------|
|        |      |        |       |       |             | FLC56XWC8V         |  |       |      |
|        |      |        |       |       |             | Tech Bes LCD-00175 |  | CUST. |      |
| EDIT   | DATE | DESIG. | CHECK | APPR. | DESCRIPTION |                    | FUJITSU DISPLAY TECHNOLOGIES CORPORATION |       | 14 / |
| DESIG. |      |        | CHECK |       |             | APPR.              |  |       |      |

10-2. Color Data Assignment

Table 10-2 shows the color data assignment.

Table 10-2. Color Data Assignment

| Color and Brightness |          | Input data ( 0 : Low level, 1 : High level) |    |    |    |    |    |    |    |    |    |    |    |    |    |    |    |    |    |    |    |    |    |    |    |
|----------------------|----------|---|----|----|----|----|----|----|----|----|----|----|----|----|----|----|----|----|----|----|----|----|----|----|----|
|                      |          | R7  | R6 | R5 | R4 | R3 | R2 | R1 | R0 | G7 | G6 | G5 | G4 | G3 | G2 | G1 | G0 | B7 | B6 | B5 | B4 | B3 | B2 | B1 | B0 |
| Basic Color          | Black    | 0   | 0  | 0  | 0  | 0  | 0  | 0  | 0  | 0  | 0  | 0  | 0  | 0  | 0  | 0  | 0  | 0  | 0  | 0  | 0  | 0  | 0  | 0  | 0  |
|                      | Blue     | 0   | 0  | 0  | 0  | 0  | 0  | 0  | 0  | 0  | 0  | 0  | 0  | 0  | 0  | 0  | 0  | 1  | 1  | 1  | 1  | 1  | 1  | 1  | 1  |
|                      | Green    | 0   | 0  | 0  | 0  | 0  | 0  | 0  | 0  | 0  | 1  | 1  | 1  | 1  | 1  | 1  | 1  | 0  | 0  | 0  | 0  | 0  | 0  | 0  | 0  |
|                      | Cyan     | 0   | 0  | 0  | 0  | 0  | 0  | 0  | 0  | 0  | 1  | 1  | 1  | 1  | 1  | 1  | 1  | 1  | 1  | 1  | 1  | 1  | 1  | 1  | 1  |
|                      | Red      | 1   | 1  | 1  | 1  | 1  | 1  | 1  | 1  | 1  | 0  | 0  | 0  | 0  | 0  | 0  | 0  | 0  | 0  | 0  | 0  | 0  | 0  | 0  | 0  |
|                      | Magenta  | 1   | 1  | 1  | 1  | 1  | 1  | 1  | 1  | 1  | 0  | 0  | 0  | 0  | 0  | 0  | 0  | 0  | 1  | 1  | 1  | 1  | 1  | 1  | 1  |
|                      | Yellow   | 1   | 1  | 1  | 1  | 1  | 1  | 1  | 1  | 1  | 1  | 1  | 1  | 1  | 1  | 1  | 1  | 0  | 0  | 0  | 0  | 0  | 0  | 0  | 0  |
|                      | White    | 1   | 1  | 1  | 1  | 1  | 1  | 1  | 1  | 1  | 1  | 1  | 1  | 1  | 1  | 1  | 1  | 1  | 1  | 1  | 1  | 1  | 1  | 1  | 1  |
| Red                  | Black    | 0   | 0  | 0  | 0  | 0  | 0  | 0  | 0  | 0  | 0  | 0  | 0  | 0  | 0  | 0  | 0  | 0  | 0  | 0  | 0  | 0  | 0  | 0  |    |
|                      | ↑        | 1   | 0  | 0  | 0  | 0  | 0  | 0  | 0  | 0  | 0  | 0  | 0  | 0  | 0  | 0  | 0  | 0  | 0  | 0  | 0  | 0  | 0  | 0  |    |
|                      | Darker   | 2   | 0  | 0  | 0  | 0  | 0  | 0  | 1  | 0  | 0  | 0  | 0  | 0  | 0  | 0  | 0  | 0  | 0  | 0  | 0  | 0  | 0  | 0  |    |
|                      | ↑        | ⋮   | ⋮  | ⋮  | ⋮  | ⋮  | ⋮  | ⋮  | ⋮  | ⋮  | ⋮  | ⋮  | ⋮  | ⋮  | ⋮  | ⋮  | ⋮  | ⋮  | ⋮  | ⋮  | ⋮  | ⋮  | ⋮  | ⋮  |    |
|                      | ↓        | ⋮   | ⋮  | ⋮  | ⋮  | ⋮  | ⋮  | ⋮  | ⋮  | ⋮  | ⋮  | ⋮  | ⋮  | ⋮  | ⋮  | ⋮  | ⋮  | ⋮  | ⋮  | ⋮  | ⋮  | ⋮  | ⋮  | ⋮  |    |
|                      | Brighter | 253   | 1  | 1  | 1  | 1  | 1  | 0  | 1  | 0  | 0  | 0  | 0  | 0  | 0  | 0  | 0  | 0  | 0  | 0  | 0  | 0  | 0  | 0  | 0  |
| Green                | Black    | 0   | 0  | 0  | 0  | 0  | 0  | 0  | 0  | 0  | 0  | 0  | 0  | 0  | 0  | 0  | 0  | 0  | 0  | 0  | 0  | 0  | 0  | 0  |    |
|                      | ↑        | 1   | 0  | 0  | 0  | 0  | 0  | 0  | 0  | 0  | 0  | 0  | 0  | 0  | 0  | 0  | 1  | 0  | 0  | 0  | 0  | 0  | 0  | 0  |    |
|                      | Darker   | 2   | 0  | 0  | 0  | 0  | 0  | 0  | 0  | 0  | 0  | 0  | 0  | 0  | 0  | 1  | 0  | 0  | 0  | 0  | 0  | 0  | 0  | 0  |    |
|                      | ↑        | ⋮   | ⋮  | ⋮  | ⋮  | ⋮  | ⋮  | ⋮  | ⋮  | ⋮  | ⋮  | ⋮  | ⋮  | ⋮  | ⋮  | ⋮  | ⋮  | ⋮  | ⋮  | ⋮  | ⋮  | ⋮  | ⋮  | ⋮  |    |
|                      | ↓        | ⋮   | ⋮  | ⋮  | ⋮  | ⋮  | ⋮  | ⋮  | ⋮  | ⋮  | ⋮  | ⋮  | ⋮  | ⋮  | ⋮  | ⋮  | ⋮  | ⋮  | ⋮  | ⋮  | ⋮  | ⋮  | ⋮  | ⋮  |    |
|                      | Brighter | 253   | 0  | 0  | 0  | 0  | 0  | 0  | 0  | 0  | 1  | 1  | 1  | 1  | 1  | 1  | 0  | 1  | 0  | 0  | 0  | 0  | 0  | 0  | 0  |
| Blue                 | Black    | 0   | 0  | 0  | 0  | 0  | 0  | 0  | 0  | 0  | 0  | 0  | 0  | 0  | 0  | 0  | 0  | 0  | 0  | 0  | 0  | 0  | 0  | 0  |    |
|                      | ↑        | 1   | 0  | 0  | 0  | 0  | 0  | 0  | 0  | 0  | 0  | 0  | 0  | 0  | 0  | 0  | 0  | 0  | 0  | 0  | 0  | 0  | 0  | 1  |    |
|                      | Darker   | 2   | 0  | 0  | 0  | 0  | 0  | 0  | 0  | 0  | 0  | 0  | 0  | 0  | 0  | 0  | 0  | 0  | 0  | 0  | 0  | 0  | 0  | 1  |    |
|                      | ↑        | ⋮   | ⋮  | ⋮  | ⋮  | ⋮  | ⋮  | ⋮  | ⋮  | ⋮  | ⋮  | ⋮  | ⋮  | ⋮  | ⋮  | ⋮  | ⋮  | ⋮  | ⋮  | ⋮  | ⋮  | ⋮  | ⋮  | ⋮  |    |
|                      | ↓        | ⋮   | ⋮  | ⋮  | ⋮  | ⋮  | ⋮  | ⋮  | ⋮  | ⋮  | ⋮  | ⋮  | ⋮  | ⋮  | ⋮  | ⋮  | ⋮  | ⋮  | ⋮  | ⋮  | ⋮  | ⋮  | ⋮  | ⋮  |    |
|                      | Brighter | 253   | 0  | 0  | 0  | 0  | 0  | 0  | 0  | 0  | 0  | 0  | 0  | 0  | 0  | 0  | 0  | 0  | 1  | 1  | 1  | 1  | 1  | 0  | 1  |
| Blue                 | ↓        | 254   | 0  | 0  | 0  | 0  | 0  | 0  | 0  | 0  | 0  | 0  | 0  | 0  | 0  | 0  | 0  | 1  | 1  | 1  | 1  | 1  | 1  | 0  |    |
|                      | Blue     | 255   | 0  | 0  | 0  | 0  | 0  | 0  | 0  | 0  | 0  | 0  | 0  | 0  | 0  | 0  | 0  | 1  | 1  | 1  | 1  | 1  | 1  | 0  |    |
|                      |          |   |    |    |    |    |    |    |    |    |    |    |    |    |    |    |    |    |    |    |    |    |    |    |    |

Note.1) Definition of gray scale : Color (n) ---"n" indicates gray scale level.

The gray scale is brighter as the number is larger.

Note.2) Data; 1: High, 0: Low

Note.3) By inputting 8-bit data signal for each red, green and blue, this module can display 256 gray scale independently for each color.

Therefore, the module is able to display 16 million colors. Color data are 24 lines.

DOCUMENT CONTROL SECTION

DATE

FLC56XWC8V

Tech Bes LCD-00175

CUST.

|      |      |        |       |       |             |  |      |
|------|------|--------|-------|-------|-------------|--|------|
| EDIT | DATE | DESIG. | CHECK | APPR. | DESCRIPTION | FUJITSU DISPLAY TECHNOLOGIES CORPORATION | 15 / |
|      |      |        | CHECK |       | APPR.       |  |      |



10-3. Input Signal Timing

Table 10-3 and Fig.10-3 shows the input signal timing.

Table 10-3. Timing Characteristics

(T=0~50°C, Vcc=12±0.5V)

| Item                   |            | Symbol         | Min.     | Typ.   | Max.     | Unit   | Remark        |      |         |
|------------------------|------------|----------------|----------|--------|----------|--------|---------------|------|---------|
| DCLK signal<br>(Clock) | Period     | Tc             | (12.500) | 15.382 | (20.000) | ns     | fc=1/Tc<br>*1 |      |         |
|                        | Frequency  | fc             | (50.00)  | 65.01  | (80.00)  | MHz    |               |      |         |
|                        | Duty       | Tch/Tc         | 45       | 50     | 55       | %      |               |      |         |
|                        | High time  | TclhH          | 5.0      | —      | —        | ns     |               |      |         |
|                        | Low time   | TclL           | 5.0      | —      | —        | ns     |               |      |         |
|                        | Rise time  | Tclkr          | —        | —      | 5.0      | ns     |               |      |         |
|                        | Fall time  | Tclkf          | —        | —      | 5.0      | ns     |               |      |         |
| DCLK-Data<br>Timing    | Setup time | Tset           | 4.5      | —      | —        | ns     |               |      |         |
|                        | Hold time  | Thold          | 6.5      | —      | —        | ns     |               |      |         |
| Data-ENAB timing       | Horizontal | Period         | Th       | (1340) | 1344     | (2000) | DCLK          | *2,3 |         |
|                        |            | Frequency      | fh       | (46.6) | 48.3     | (55.5) | kHz           |      |         |
|                        |            | Display period | Thd      | 1280   | 1280     | 1280   | DCLK          |      |         |
|                        | Vertical   | Period         | Tv       | (776)  | 806      | 806    | Th            |      | 16.67ms |
|                        |            | Frequency      | 1/Tv     | —      | 60       | —      | Hz            |      |         |
|                        |            | Display period | Tvd      | 768    | 768      | 768    | Th            |      | *2,3    |
| Data-ENAB timing       |            | Tdn            | 0        | 0      | 0        | DCLK   | *4            |      |         |

\*1) DCLK signal input must be valid while power supply is applied.

\*2) Display position is specified by the ENAB signal only.

Horizontal display position is specified by the rise of ENAB signal. The data which is latched by the falling edge of 1st DCLK right after the rise of ENAB, is displayed on the left edge of the screen.

Vertical display position is specified by the rise of ENAB after a "Low" level period equivalent to eight times of horizontal period. The 1st data corresponding to one horizontal line after the rise of ENAB is displayed at the top line of screen.

\*3) If a period of ENAB "High" is less than 1280 DCLK or less than 768 lines, the rest of the screen displays black.

\*4) The display position does not fit to the screen if a period of ENAB "High" and the effective data period do not synchronize with each other.

DOCUMENT CONTROL SECTION

DATE

|        |      |        |       |       |             |                    |  |
|--------|------|--------|-------|-------|-------------|--------------------|--|
|        |      |        |       |       |             | FLC56XWC8V         |  |
|        |      |        |       |       |             | Tech Bes LCD-00175 |  |
|        |      |        |       |       |             | CUST.              |  |
| EDIT   | DATE | DESIG. | CHECK | APPR. | DESCRIPTION |                    | FUJITSU DISPLAY TECHNOLOGIES CORPORATION |
| DESIG. |      |        | CHECK |       | APPR.       |                    | 16/                                      |

1

2

3

4

【FLC56XWC8V】

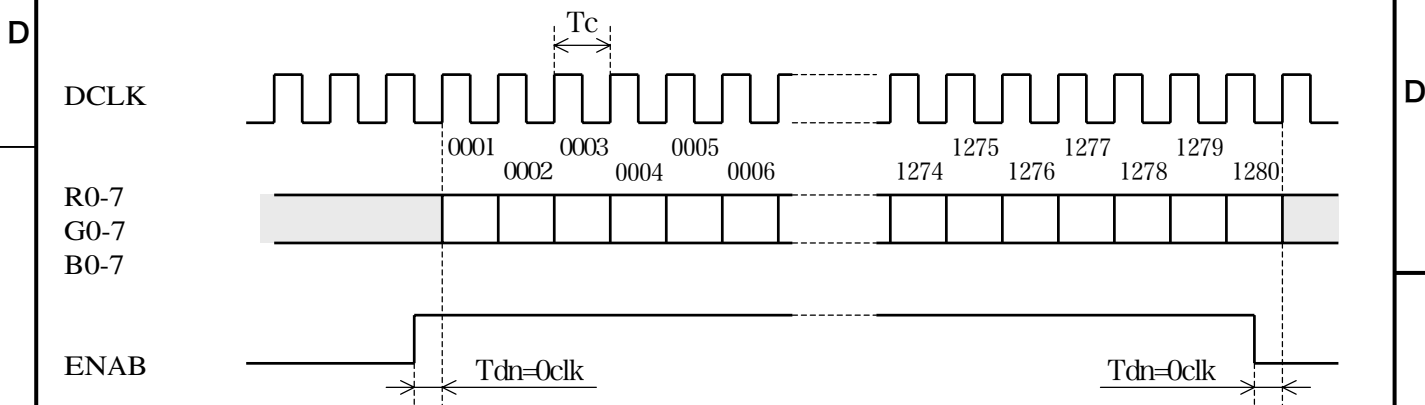
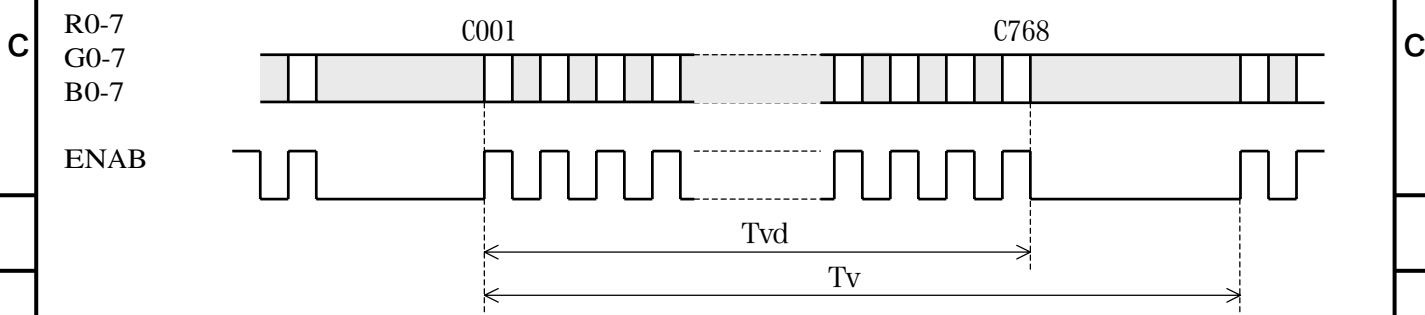
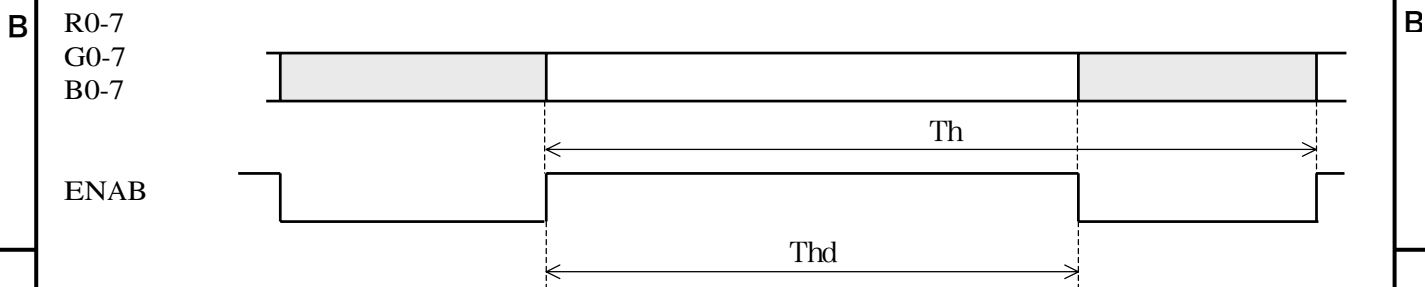
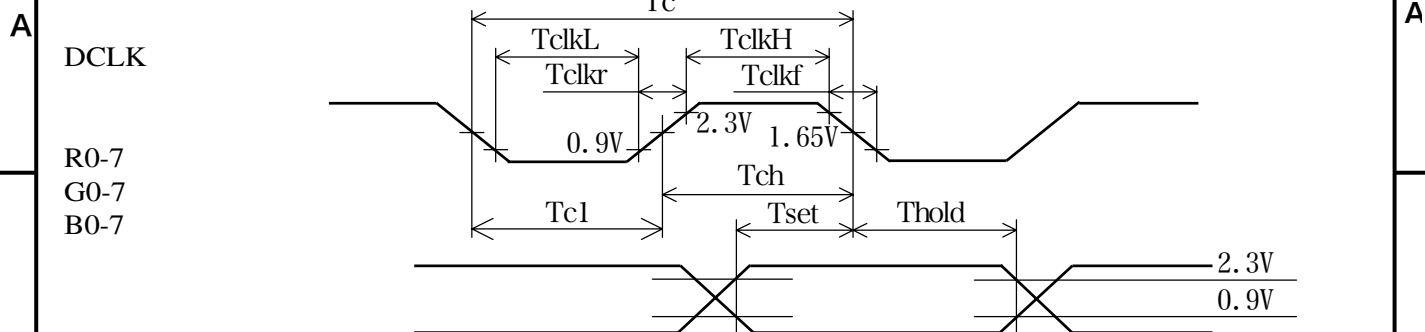

Fig.10-3.Input Signal Timing Chart

DOCUMENT CONTROL SECTION

DATE

|        |      |        |       |       |             |                    |  |
|--------|------|--------|-------|-------|-------------|--------------------|--|
|        |      |        |       |       |             | FLC56XWC8V         |  |
|        |      |        |       |       |             | Tech Bes LCD-00175 |  |
|        |      |        |       |       |             | CUST.              |  |
| EDIT   | DATE | DESIG. | CHECK | APPR. | DESCRIPTION |                    | FUJITSU DISPLAY TECHNOLOGIES CORPORATION |
| DESIG. |      |        | CHECK |       | APPR.       |                    | 17 /                                     |

1

F

10-4. Correspondence between Data and Display Position

Fig.10-4 shows the Correspondence between Data and Display Position.

|      |           |           |           |           |           |           |           |           |       |           |           |
|------|-----------|-----------|-----------|-----------|-----------|-----------|-----------|-----------|-------|-----------|-----------|
|      | S0001     | S0002     | S0003     | S0004     | S0005     | S0006     | S0007     | S0008     | ..... | S3839     | S3840     |
| C001 | R<br>0001 | G<br>0001 | B<br>0001 | R<br>0002 | G<br>0002 | B<br>0002 | R<br>0003 | G<br>0003 |       | G<br>1280 | B<br>1280 |
| C768 | R<br>0001 | G<br>0001 | B<br>0001 | R<br>0002 | G<br>0002 | B<br>0002 | R<br>0003 | G<br>0003 |       | G<br>1280 | B<br>1280 |

Fig.10-4. Correspondence Data and Display Position

10-5. Power Supply Sequence

The sequence of input signals and On/Off of the power supply of this LCD module should be in the specification shown in Fig.10-5 to prevent latch-up of the driver ICs and DC driving of the LCD panel.

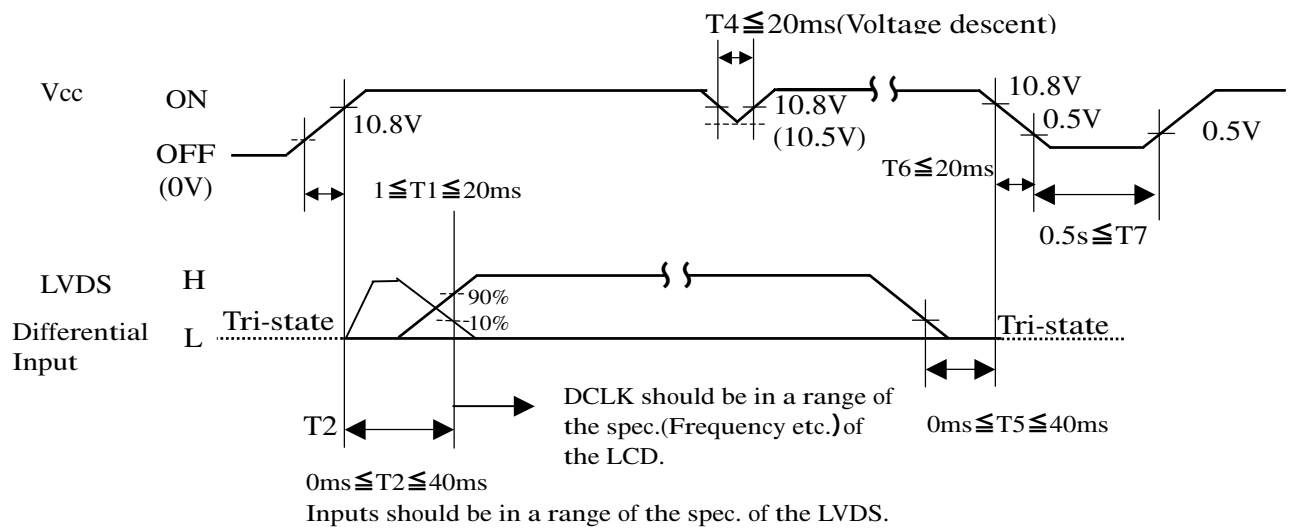

Fig.10-5. Power Supply Sequence

DOCUMENT CONTROL SECTION

|        |      |        |       |       |             |  |  |
|--------|------|--------|-------|-------|-------------|--|--|
|        |      |        |       |       |             | FLC56XWC8V                               |  |
|        |      |        |       |       |             | Tech Bes LCD-00175                       |  |
|        |      |        |       |       |             | CUST.                                    |  |
| EDIT   | DATE | DESIG. | CHECK | APPR. | DESCRIPTION | FUJITSU DISPLAY TECHNOLOGIES CORPORATION |  |
| DESIG. |      |        | CHECK |       | APPR.       | 18 /                                     |  |

### 11. BACKLIGHT SPECIFICATIONS

#### 11-1. Pin Configuration for Backlight

Table 11-1 shows the description and Pin assignment of the connectors (CN-2,3) for the Back-light of this LCD module.

Table 11-1-1 Pin Assignment of CN-2

| Pin No. | Signal           | Function              |
|---------|------------------|-----------------------|
| 1       | V <sub>INV</sub> | Power supply          |
| 2       | V <sub>INV</sub> | Power supply          |
| 3       | V <sub>INV</sub> | Power supply          |
| 4       | V <sub>INV</sub> | Power supply          |
| 5       | V <sub>INV</sub> | Power supply          |
| 6       | GND              | Ground (High voltage) |
| 7       | GND              | Ground (High voltage) |
| 8       | GND              | Ground (High voltage) |
| 9       | GND              | Ground (High voltage) |
| 10      | GND              | Ground (High voltage) |

Connector : S10B-PH-SM3-TB

User's Connector: PHR-10

Supplier:  
Japan so dlerless terminal manufacturing Co.Ltd.

Note1) N.C terminal should keep open.

Table 11-1-2 Pin Assignment of CN-3

| Pin No. | Signal           | Function             |
|---------|------------------|----------------------|
| 1       | V <sub>VR</sub>  | Brightness control   |
| 2       | N.C.             | N.C.                 |
| 3       | N.C.             | N.C.                 |
| 4       | V <sub>cnt</sub> | Lighting control     |
| 5       | N.C.             | N.C.                 |
| 6       | GND              | Ground (low voltage) |

Connector : S6B-PH-SM3-TB<sup>③</sup>

User's Connector: PHR-6

Supplier:  
Japan so dlerless terminal manufacturing Co.Ltd.

Note1) N.C terminal should keep open.

Note2) V<sub>VR</sub> input:  
0V=Max. Brightness  
3.5V=Min. brightness

Note3) V<sub>cnt</sub> input:  
0V=BL turn on  
2.1V or more = BL turn off

Note4) Keep the circuit GND (CN-3 6pin) apart from high-voltage GND (CN-2 6-10pin). Otherwise, the screen may cause flickering.

DOCUMENT CONTROL SECTION

DATE

|        |          |        |       |       |  |                    |  |
|--------|----------|--------|-------|-------|--|--------------------|--|
|        |          |        |       |       |  | FLC56XWC8V         |  |
|        |          |        |       |       |  | Tech Bes LCD-00175 |  |
|        |          |        |       |       |  | CUST.              |  |
| 03     | 20030526 |        |       |       | Correct connector type                   |                    |  |
| EDIT   | DATE     | DESIG. | CHECK | APPR. | DESCRIPTION                              |                    |  |
| DESIG. |          |        | CHECK |       | FUJITSU DISPLAY TECHNOLOGIES CORPORATION |                    |  |
|        |          |        |       |       |  | 19 /               |  |

【FLC56XWC8V】

11-2 CCFL

Supplier: SANKEN ELECTRONICS Co.LTD. Part No.: T.B.D

11-3 Life

The life of the back-light is a minimum of 50,000 hours at the following conditions.

(1) Working conditions

- ① Ambient temperature : 25±5°C
- ② Brightness control (Vvr) : 0V

(2) Definition of life

- ① Brightness becomes 50% or less than the minimum brightness value shown in Table 9-1.
- ② The lamp no longer lights
- ③ Lamp being flashing or flickering.

A

A

B

B

C

C

D

D

E

|                          |  |
|--------------------------|--|
| DOCUMENT CONTROL SECTION |  |
| DATE                     |  |

|      |        |        |       |       |             |                    |  |       |
|------|--------|--------|-------|-------|-------------|--------------------|--|-------|
|      |        |        |       |       |             | FLC56XWC8V         |  |       |
|      |        |        |       |       |             | Tech Bes LCD-00175 |  | CUST. |
| EDIT | DATE   | DESIG. | CHECK | APPR. | DESCRIPTION |                    | FUJITSU DISPLAY TECHNOLOGIES CORPORATION | 20 /  |
|      | DESIG. |        | CHECK |       |             | APPR.              |  |       |

F

### 12. APPEARANCE SPECIFICATIONS

#### 12-1.Appearance

Table 12-1 shows the appearance specifications. In the case of another agreement about Specification arises, that agreement takes priority.

Table12-1 Appearance Specifications

Length: L[mm], Width: W[mm]

Allowable number of pieces: N, Average diameter: D [mm]

| No. | Item             |                           | Judgment method and standard       |   | Remarks                                |  |
|-----|------------------|---------------------------|------------------------------------|---|--|--|
| 1   | Foreign Particle | White and Black points    |                                    | $D \leq 0.5$<br>$0.5 < D$                       | $N \leq 10$<br>$N \leq 0$              |  |
|     |                  | Fiber                     | Dark line                          | $W \leq 0.1$<br>$L \leq 12.0$                   | $N \leq 10$                            |  |
|     |                  |                           | Bright points                      | $D \leq 0.3$<br>$0.3 < D \leq 0.6$<br>$D > 0.6$ | Not count<br>$N \leq 12$<br>$N \leq 8$ |  |
| 2   | Scratch          | Scratch on polarizer film | $12.0 > L$                         | $N \leq 15$                                     |  |  |
| 3   | Dent             | Dent on polarizer film    | $D \leq 0.3$<br>$0.3 < D \leq 0.4$ | Not count<br>$N \leq 15$                        |  |  |

#### Note

•Foreign particle and scratch that do not effect display image, such as foreign particle between glass and polarizer film out of the display area, scratch on metal bezel, backlight module or polarizer film out of the display area are not counted.

•Unwiped dirt out of the display area is not counted.

•These items are applied to the defects in the cell when backlight is on, and defects on the surface of the polarizer film at the display area.

•Must be observed the LCD screen from the normal direction unless specified. The distance between the LCD screen and the observing position should be 35cm or more.

One 20W fluorescent lamp is used at 50cm above the worktable.

At this time, the luminance at the vertical direction to the fluorescent lamp is 300 to 600 lux (reference value).

•Appearance Specifications are defined under the condition of frame frequency at 60Hz. (include Bright and Dark points specifications)

#### 12-2.Dot defects (Bright spots, Dark spots)

##### 12-2-1.Area to be inspected

Inside display dot area (480.0 X 288.0mm)

Display dot area means active area.

One pixel consists of 3 dots (red, green and blue).

##### 12-2-2.Bright spots definition

(1) Bright spots are classified as follows. (based on brightness samples)

- Visible through 2% ND filter ..... High-bright spot ( R,G )
- Visible through 5% but invisible through 2% ND filter ..... Low-bright spot( R,G,B )
- Invisible through 5% ND filter ..... Not counted

DOCUMENT CONTROL SECTION

DATE

|        |      |        |       |       |             |                    |  |
|--------|------|--------|-------|-------|-------------|--------------------|--|
|        |      |        |       |       |             | FLC56XWC8V         |  |
|        |      |        |       |       |             | Tech Bes LCD-00175 |  |
|        |      |        |       |       |             | CUST.              |  |
| EDIT   | DATE | DESIG. | CHECK | APPR. | DESCRIPTION |                    | FUJITSU DISPLAY TECHNOLOGIES CORPORATION |
| DESIG. |      |        | CHECK |       | APPR.       |                    | 21 /                                     |

A

A

- (2) Tears, breaks, etc in color filter visible by the light passing through.
  - Bigger than a half dot..... High bright spot
  - A half dot or smaller ..... Not counted
- (3) Tears, breaks, etc in black matrix visible by the light passing through.
  - Diameter above 50 μm ..... High-bright spot
  - Diameter of 50 μm or smaller ..... Not counted

12-2-3. Number of bright spot standard

B

B

| Item                      | Entire Screen     |                           |
|---------------------------|-------------------|---------------------------|
|                           | High-bright spots | High and Low Bright Spots |
| Brightness classification | High-bright spots | High and Low Bright Spots |
| Number of defects         | 15 or less        | 22 or less                |

NOTES :

1. Display should be all black when bright spots are counted.
2. Number of two high Bright spots connections is up to 3.
3. Number of two low Bright spots connections is up to 12.
4. Number of three Bright spots connections and two high Bright spots vertical connections is 0.
5. Number of high Bright spots and low Bright spots connections is up to 5.

C

C

12-2-4. Distance between Bright spots

- Distance between Bright spots( not include B) ..... 15 mm or more
- Distance between Bright spots( include B) ..... 5 mm or more  
(Distance to the third defect should be 20mm or more)

12-2-5. Number of Dark spots standard

D

D

| Item                                  | Entire Screen   |
|---------------------------------------|---|
| Number of defects                     | 24 or less  |
| Number of two dark spot connections   | 12 or less<br>(Not include vertical, horizontal and diagonal connections) |
| Number of three dark spot connections | 3 or less   |

NOTES :

1. Display should be all white when dark spot is counted.
2. Distance between defects is 5 mm or more.  
(Distance to the third defect should be 20mm or more)
3. If dark spot size is smaller than one dot, convert with following rule and sum up.
  - (a)  $A < 1/3$  : Not counted.
  - (b)  $1/3 \leq A < 2/3$  : Considered as 0.5 dot.
  - (c)  $2/3 \leq A$  : Considered as 1 dot.

(A= Dark spot size / dot size)

DOCUMENT CONTROL SECTION

DATE

E

|        |      |        |       |       |             |  |  |
|--------|------|--------|-------|-------|-------------|--|--|
|        |      |        |       |       |             | FLC56XWC8V                               |  |
|        |      |        |       |       |             | Tech Bes LCD-00175                       |  |
|        |      |        |       |       |             | CUST.                                    |  |
| EDIT   | DATE | DESIG. | CHECK | APPR. | DESCRIPTION | FUJITSU DISPLAY TECHNOLOGIES CORPORATION |  |
| DESIG. |      |        | CHECK |       | APPR.       | 22 /                                     |  |

F

### 13. ENVIRONMENTAL SPECIFICATIONS

Table 13-1 shows the environmental specifications.

Table 13-1. Environmental Specifications

| Item        | Condition     |   | Remark   |
|-------------|---------------|---|--|
| Temperature | Operation     | 0~45°C  | Note1  |
|             | Storage       | -20~60°C  |  |
| Humidity    | Operation     | 20~85%RH  | Maximum wet-bulb temperature should not exceed 29°C.<br>No condensation. |
|             | Storage       | 5~85%RH   |  |
| Vibration   | Non-operation | 10~500Hz, 1 cycle/20minute,<br>2G, 1.5mm max, 2hour each X,<br>Y and Z directions | For single module without package.(Note2)                                |
| Shock       | Non-operation | 30G, 6ms, 1time each<br>±X, ±Y and ±Z directions.                                 |  |

Note1: Temperature on surface of LCD panel should be under (54)°C.

Note2: Table 13-2 and Fig. 13-1 show the shock resistance standard when module is packaged.

Table 13-2. Shock Resistance Standard when Module is Packaged

| Dropping location | Dropping height | Count  |
|-------------------|-----------------|--------|
| A ~ J             | 60cm            | 1 time |

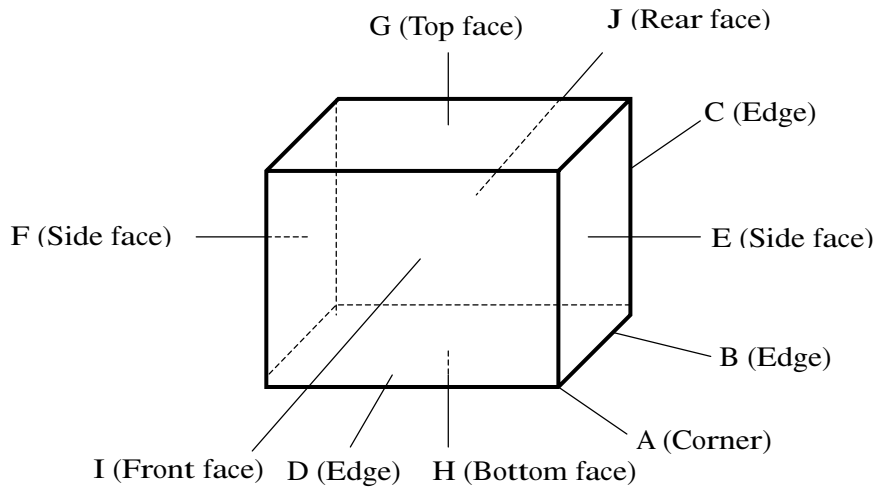

Fig.13-1. Direction to apply shock to package

DOCUMENT CONTROL SECTION

DATE

|        |      |        |       |       |             |                    |  |
|--------|------|--------|-------|-------|-------------|--------------------|--|
|        |      |        |       |       |             | FLC56XWC8V         |  |
|        |      |        |       |       |             | Tech Bes LCD-00175 |  |
|        |      |        |       |       |             | CUST.              |  |
| EDIT   | DATE | DESIG. | CHECK | APPR. | DESCRIPTION |                    | FUJITSU DISPLAY TECHNOLOGIES CORPORATION |
| DESIG. |      |        | CHECK |       | APPR.       |                    |  |
|        |      |        |       |       |             | 23 /               |  |



### 14. INDICATIONS

This module has the following indications.

- (1) Product name : LCD unit
- (2) Model number : FLC56XWC8V
- (3) Product drawing number: NA19026-C951

(4) Manufacturing number : 3 5 0 0 0 0 1

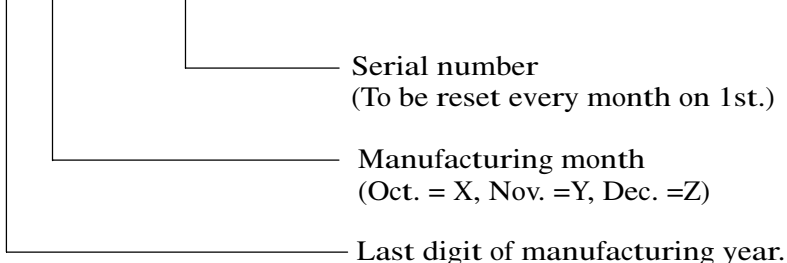

- (5) Version number : 01A (Example)  
 -1st 2 digits "01" means operational version.  
 -3rd alphabet means functional version.

(6) Country of origin : MADE IN JAPAN

(7) Company name : FUJITSU DISPLAY TECHNOLOGIES CORP.

(8) Caution when changing cold-cathode tubes and disposal method of them. (See Fig. 14-1)

・WHEN CHANGING COLD CATHODE FLUORESCENT LAMPS, FOLLOW OPERATING SPECIFICATIONS, ESPECIALLY BE CAREFUL ABOUT THE LAMP'S SIDE-EDGE.  
 ・蛍光管の交換は作業仕様書に従って行って下さい。特に蛍光管ホルダ側面のエッジに気をつけて下さい。

・THIS TFT COLOR LCD CONTAINS COLD CATHODE FLUORESCENT LAMPS. PLEASE FOLLOW LOCAL ORDINANCES OR REGULATIONS FOR ITS DISPOSAL.  
 ・当該液晶ディスプレイユニットには蛍光管が組み込まれていますので、地方自治体の条例または規則に従って廃棄して下さい。

Fig.14-1

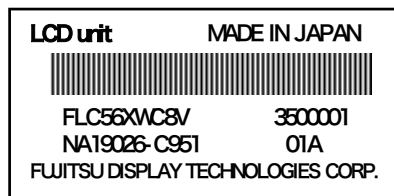

Fig.14-2 Product label (example)

### 15. PACKAGING

Separately specified in packaging specifications.

#### 15-1. Packaging specifications

- (1) 5 LCD modules / 1 package.
- (2) Weight: approximately (14) kg / 1 package.
- (3) Outline dimensions : (T.B.D) mm(W) × (T.B.D) (D) × (T.B.D) mm(H)

#### 15-2. Packaging method

Fig.15-2 (a),(b),(c),(d) show the packing method.

DOCUMENT CONTROL SECTION

DATE

|        |      |        |       |       |  |                    |  |
|--------|------|--------|-------|-------|--|--------------------|--|
|        |      |        |       |       |  | FLC56XWC8V         |  |
|        |      |        |       |       |  | Tech Bes LCD-00175 |  |
|        |      |        |       |       |  | CUST.              |  |
| EDIT   | DATE | DESIG. | CHECK | APPR. | DESCRIPTION                              |                    |  |
| DESIG. |      |        | CHECK |       | FUJITSU DISPLAY TECHNOLOGIES CORPORATION |                    |  |
|        |      |        |       |       |  | 24 /               |  |

16.WARRANTY

The warranty period is one year after shipping. Products which fail during this period are repaired or replaced without charge, unless the failure is caused by user.

17.PRECAUTIONS

Adhere to the following precautions to properly use this LCD module.

(1) Fail safe design

LCD module has an inherent chance of failure. Customers must protect against injury, damage or loss from such failures by incorporating safety design measures into your facility and equipment such as redundancy, fire protection, and prevention of over-current levels and other abnormal operating conditions.

(2) Handling of LCD panel

①Do not apply any strong mechanical shock to the LCD panel.

Since the LCD panel is made of glass, excessive shock may damage the panel or cause a malfunction.

②Do not press hard on the LCD panel surface.

In the LCD panel, the gap between two glass plates is kept precisely and uniformly to maintain display's characteristics and reliability. If this panel is pressed hard, the following troubles occurs.

- (a) Ununiformity of color
- (b) Orientation of liquid crystal becomes disordered

Problem (a) returns to normal after a while. Problem (b) returns to normal if power is shut off once then turned on again.

However these operations should be avoided to insure reliability.

③Do not scratch the polarizer film on the LCD panel surface.

- Do not press or rub the display surface with a hard tool, pincet, etc.
- For handling, use cotton or conductive gloves so that the display surface is not stained.
- For If the display surface is stained by dust or dirt, clean it as follows with a soft cloth (deer skin, etc.)

[Dust] Wipe off with a soft cloth. (do not rub.)

[Dirt ] Wipe off lightly with a soft cloth after soaking in the clear water and squeezing hard out of water drops. Only if the dirt is hardly wiped off, use isopropyl alcohol or ethanol.

Be careful not to splash the water or the solvent and water penetrated between the polarizer and the LCD panel.

Do not use solvents such as ketone (acetone, etc.) and aromatics (xylene, toluene, etc.)

- If saliva or water drops are left for long time, it may deform partial deformation or discolored. Wipe off immediately in the same way as for dirt.

- Do not allow oil to adhere to the module, since the cleaning of oil is difficult.

④Do not place or contact objects on the display surface for a long period of time.

That's because this may make some parts of the LCD module distorted and the display quality may decline.

DOCUMENT CONTROL SECTION

DATE

|        |      |        |       |       |             |                    |  |
|--------|------|--------|-------|-------|-------------|--------------------|--|
|        |      |        |       |       |             | FLC56XWC8V         |  |
|        |      |        |       |       |             | Tech Bes LCD-00175 |  |
|        |      |        |       |       |             | CUST.              |  |
| EDIT   | DATE | DESIG. | CHECK | APPR. | DESCRIPTION |                    | FUJITSU DISPLAY TECHNOLOGIES CORPORATION |
| DESIG. |      |        | CHECK |       | APPR.       |                    |  |
|        |      |        |       |       |             | 25 /               |  |

(3) Handling of LCD module

① Assemble the module into user's system in a dust free environment.

If conductive foreign matter adheres to the module, failures may occur.

② Take anti-static measures for assembling the module.

Since the LCD module contains CMOS-ICs, the following considerations are necessary.

- For assembling the module, operator should be grounded and wear cotton or conductive gloves.
- Floor of work area and work table to assemble the LCD module should be covered with electrostatic shielding in order to discharge static electricity via an earth wire.
- If necessary, ground operation tools (soldering iron, radio pliers, pincet, etc.).
- Do not take the module out of the conductive bag until the time when the module is assembled.
- Assemble the module under low humidity (50%RH or less).

③ Do not pull the connecting cable on the rear face of the LCD module strongly.

④ Do not disassemble or remodel the LCD module.

If this LCD module is disassembled or remodeled, it may have some trouble, or the display quality and reliability may not be assured.

(4) Precautions for operating the LCD module

① Adhere to the specified power supply sequence.

If not followed, the CMOS-IC may cause a latch-up, or the DC voltage may be applied the liquid crystal, and a failure or serious deterioration in display quality may occur.

② Do not operate the LCD module when condensation is present.

If the LCD module is operated when condensation is on the terminals of the LCD panel, the terminals cause electrochemical reaction, and may reach disconnection. Condensation easily occurs especially when the module is moved from a cold environment to a warm environment.

③ Trouble that occurs when the LCD module is used at not recommended temperature.

- Operation at high temperature(>60°C) :Display colors shift to blue.
- Storage at high temperature(>60°C) :The polarizer film deteriorates and contrast decreases.
- Operation at low temperature(<0°C) :The response speed decreases considerably.
- Storage at low temperature (<-20°C) :The liquid crystal may solidify and become damaged.

④ Always input the control signals at the correct timing.

If control signals (DCLK, or ENAB) are not input, or if the timing is out of the specified timing, DC voltage may be applied to the liquid crystal and, as a result, cause image sticking or deterioration of contrast.

(5) Precautions on designing module mounting

① Do not press the display surface and bottom face of the LCD module.

Display quality or reliability may be deteriorated if the installation of the LCD module is inappropriate and, as a result, excessive pressure is applied to the surface of LCD screen. Brightness uniformity or the reliability of CCFL may decrease if the pressure is applied to the backlight module.

DOCUMENT CONTROL SECTION

DATE

|        |      |        |       |       |             |                    |  |
|--------|------|--------|-------|-------|-------------|--------------------|--|
|        |      |        |       |       |             | FLC56XWC8V         |  |
|        |      |        |       |       |             | Tech Bes LCD-00175 |  |
|        |      |        |       |       |             | CUST.              |  |
| EDIT   | DATE | DESIG. | CHECK | APPR. | DESCRIPTION |                    | FUJITSU DISPLAY TECHNOLOGIES CORPORATION |
| DESIG. |      |        | CHECK |       | APPR.       |                    | 26 /                                     |

A

A

②Consider the module mounting design, so that twisting and bending do not occur to the LCD module.

Excessive twisting and bending may damage display quality and reliability.

③The power cable length between the LCD module and inverter should not be extended. Otherwise the backlight may not light or flickering may occur.

④Do not make the power cable of the backlight clung to a metal plate, etc.

Backlight frequency current for backlight driving may leak to the metal and desired brightness may not be assured.

⑤When Mounting LCD module with M3 screw(x4) should be screw up under 30N-cm torque.

(6) Storage method

B

B

①Do not store the LCD module in an atmosphere of organic solvent or corrosive gas.

In an organic solvent atmosphere, the polarizer film discolors and display quality deteriorates.

In a corrosive gas environment, various problems may occur.

②Store the LCD module in a Fujitsu package.

At storing, Fujitsu packages can be stacked up to (T.B.D) boxes.

The LCD module is in an anti-static bag. Keep the module in that status.

③It is recommended that the storage environment should be humidity controlled, cool and dark.

Recommended storage environment

- Place :Dark (avoid direct sunlight)
- Temperature : 10~35°C
- Humidity : 50~60%RH

Note) If the module is left in an environment of 60°C or more for a long period of time, optical characteristics may deteriorate.

C

C

(7) Storage method

D

D

① If the LCD panel is damaged, do not inhale or allow the liquid crystal to enter the mouth

If the liquid crystal contacts the body or cloths, wash it off with soap immediately. Follow precautions for regular electronic components.

② Solder flux on the printed circuit board is harmless to the quality and reliability of LCD module.

Fujitsu is practicing non-wash technology on module assembly process.

D

18. MISCELLANEOUS

Specifications of the TFT-LCD panel and other components used in the LCD module are subject to change. Both parties shall discuss together before change.

If any doubt is raised in the content of the specifications, both parties shall discuss and make best effort for the agreement.

E

DOCUMENT CONTROL SECTION

DATE

|        |      |        |       |       |  |                    |  |
|--------|------|--------|-------|-------|--|--------------------|--|
|        |      |        |       |       |  | FLC56XWC8V         |  |
|        |      |        |       |       |  | Tech Bes LCD-00175 |  |
|        |      |        |       |       |  | CUST.              |  |
| EDIT   | DATE | DESIG. | CHECK | APPR. | DESCRIPTION                              |                    |  |
| DESIG. |      |        | CHECK |       | FUJITSU DISPLAY TECHNOLOGIES CORPORATION |                    |  |
|        |      |        |       |       |  | 27 /               |  |

F

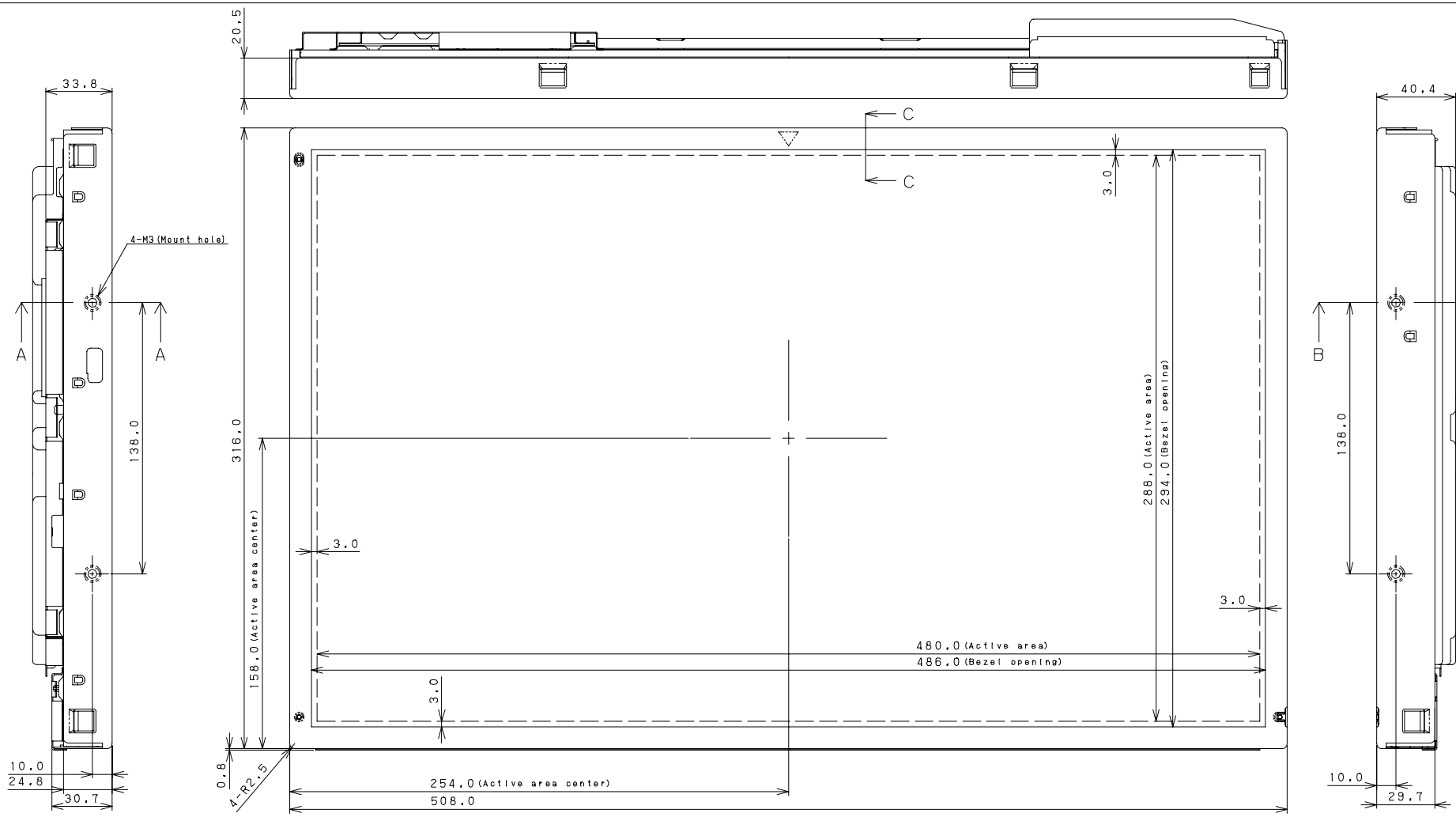

**NOTE**

1) Unspecifild tollerrance to be  $\pm 0.5$ .

|             |      |                |       |             |       |                    |     |
|-------------|------|----------------|-------|-------------|-------|--------------------|-----|
| MATER.      |      | FINISH         |       | TITLE       |       | SCALE              |     |
|             |      |                |       | FLC56XWC8V  |       | 1 : 2              |     |
| 03 20030526 |      | Total revision |       | DRAW. NO.   |       | Tech Bes LCD-00175 |     |
| EDIT.       | DATE | DESIG.         | CHECK | DESCRIPTION |       | DESIGNER           | 28/ |
| DESIG.      |      |                | CHECK |             | APPR. |                    |     |

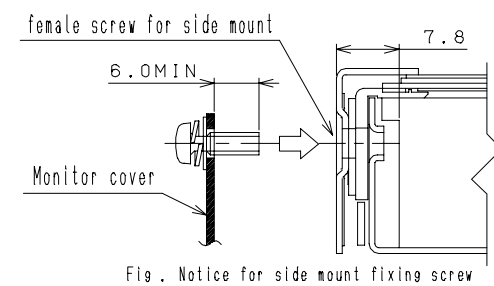
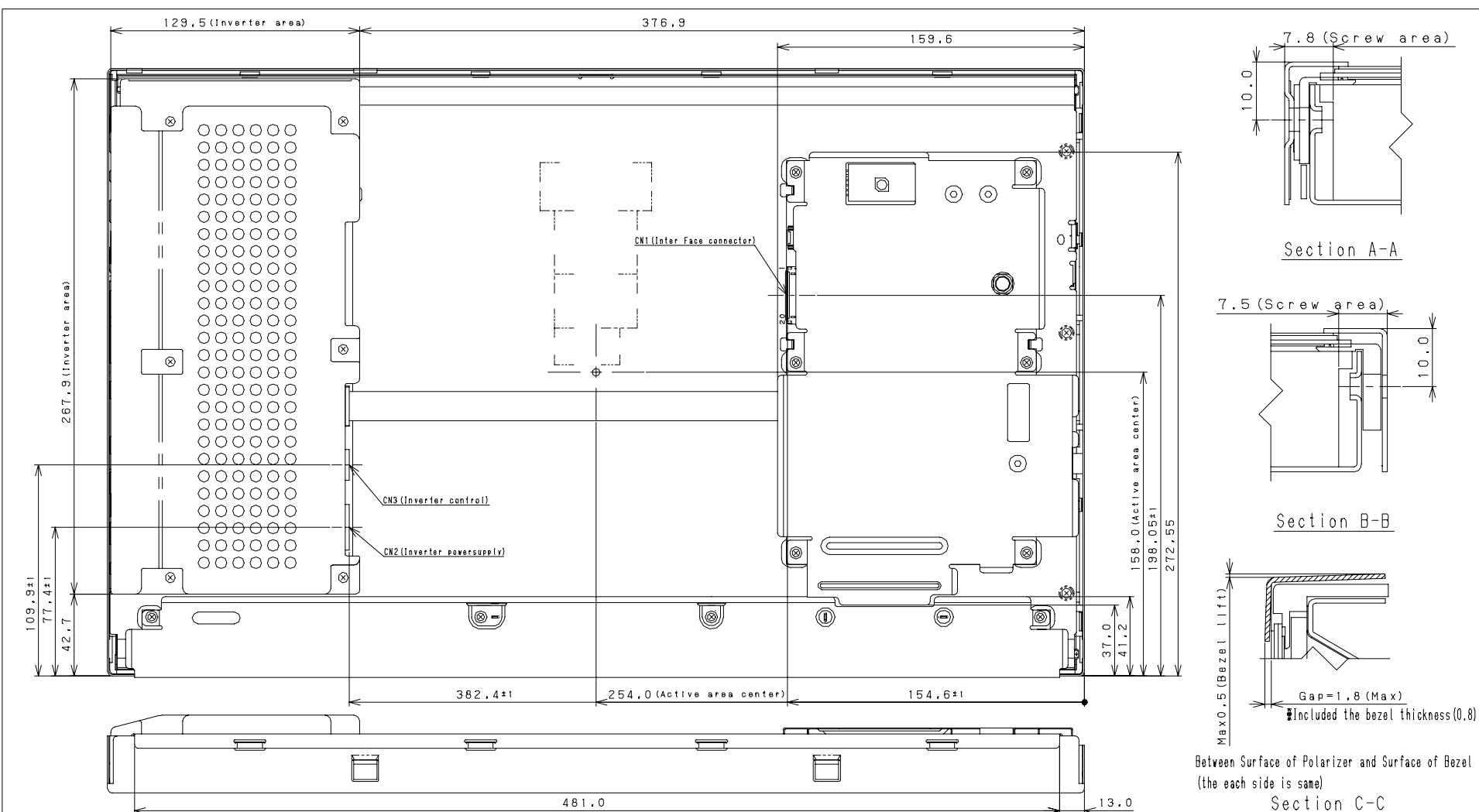

Note1) Fixing screw of LCD module must have screw part length of more than 6.0mm with unfixing condition. Otherwise fixing screw may not be fixed screwed.

Note2) The length of the screw after fixing must be shorter than the screw area.

|             |      |                    |       |             |       |       |  |
|-------------|------|--------------------|-------|-------------|-------|-------|--|
| MATER.      |      | FINISH             |       | TITLE       |       | SCALE |  |
|             |      |                    |       | FLC56XWC8V  |       | 1 : 2 |  |
| DRAW. NO.   |      | Tech Bes LCD-00175 |       | DRAW. NO.   |       |       |  |
| 03 20030526 |      | Total revision     |       |             |       |       |  |
| EDIT.       | DATE | DESIG.             | CHECK | DESCRIPTION |       |       |  |
| DESIG.      |      |                    | CHECK |             | APPR. |       |  |
|             |      |                    |       |             |       | 29/   |  |