

	I	Page No.	1/26
Document No.	DC170-004947	Revision	1.0

TO :

Date : 2010/02/22

Customer Acceptance Specification

**Model : HSD022B2N6-A00
HSD022B2N6-B00**

Accepted by:	
Signature	Date
_____	_____
Proposed by: Technical Service Division	
Signature	Date
_____	_____

Note:1. Please contact HannStar Display Corp. before designing your product based on this module specification.

2. The information contained herein is presented merely to indicate the characteristics and performance of our products. No responsibility is assumed by HannStar for any intellectual property claims or other problems that may result from application based on the module described herein.

	I	Page No.	2/26
Document No.	DC170-004947	Revision	1.0

Record of Revisions

Rev.	Date	Sub-Model	Description of change
1.0	2010/02/22	A00/B00	Formal Product Specification was first issued.

	I	Page No.	3/26
Document No.	DC170-004947	Revision	1.0

Contents

1.0	General description	p.4
2.0	Absolute maximum ratings	p.5
3.0	Electrical characteristics	p.6
4.0	Optical characteristics	p.10
5.0	Pixel Format	p.13
6.0	Outline dimension	p.14
7.0	Reliability test items.....	p.19
8.0	Lot mark	p.20
9.0	Package specification.....	p.22
10.0	General precaution	p.24

	I	Page No.	4/26
Document No.	DC170-004947	Revision	1.0

1.0 GENERAL DESCRIPTION

1.1 Introduction

HannStar Display model HSD022B2N6-A/B is a color active matrix thin film transistor (TFT) liquid crystal display without polarizer. This model is composed of amorphous silicon TFT as a switching device. It is a transmissive type display operating in the normally white mode.

This TFT LCD has a 2.2-inch diagonally measured active display area with 528 x 220 dot (176 vertical by 220 horizontal pixel) resolution. Each pixel is divided into Red, Green, Blue dots which are arranged in vertical stripes.

1.2 Applications

- Mobile device applications (cell phone, MP3, MP4,...)

1.3 General information

Item		Specification	Unit
Glass Dimension	HSD022B2N6-A00	38.048(H) x 50.16(V) x 1.0	mm
	HSD022B2N6-B00	38.048(H) x 50.16(V) x 0.6	
Display area		34.848(H) x 43.56(V)	mm
Number of Pixel		176 RGB(H) x 220(V)	pixels
Pixel pitch		0.198(H) x 0.198(V)	mm
Pixel arrangement		RGB Vertical stripe	
Display mode		Normally white	
Display Color		262K(6bit)	

	I	Page No.	5/26
Document No.	DC170-004947	Revision	1.0

2.0 ABSOLUTE MAXIMUM RATINGS

(The following are maximum values which, if exceeded, may cause operation or damage to the unit.)

Item	Symbol	Min.	Max.	Unit	Note
LC Operating Voltage	VOP	--	4.5	V	*1, *2
Operating Temperature	T _{OP}	-20	70	°C	
Storage Temperature	T _{ST}	-30	80	°C	
Operating Ambient Humidity	H _{OP}	10	*4	RH	*3
Storage Humidity	H _{ST}	10	*4	RH	*3

Note:

- *1. At 25±5°C
- *2. Due to the characteristics of LC Material, the Liquid Crystal driving voltage varies with environmental temperature.
- *3. Non-condensation.
- *4. Temp. ≤ 60°C, 90%RH Max.
Temp. > 60°C, Absolute humidity shall be less than 90%RH.

	I	Page No.	6/26
Document No.	DC170-004947	Revision	1.0

3.0 Electrical Specifications

Item	Symbol	Min.	Typ.	Max.	Unit	Note
TFT Gate ON Voltage	VGH		15		V	*1,*2
TFT Gate OFF Voltage	VGL	--	-7.5		V	
TFT Common Voltage	Vcom	-1.0	--	3.8	V	
Data (RGB signal) Voltage	Vsig	0.2	--	5.2	V	

Note:

*1. VGH is TFT Gate operating Voltage.

*2. VGL is TFT Gate operating Voltage.

The storage structure of this model is C_{ST} (Storage on Common)

*3. Vcom must be adjusted to optimize display quality _Cross talk, Contrast Ratio and etc.

		I	Page No.	7/26
Document No.	DC170-004947		Revision	1.0

3.1 FPC PIN ASSIGNMENT



1	DUMMY	36	M	71	VCL	106	VGL
2	DUMMY	37	SDO	72	VCI	107	VGL
3	VCOM	38	IM<0>	73	VCI	108	VGL
4	VCOM	39	IM<1>	74	VCI	109	VGH
5	VCOM	40	IM<2>	75	AVDD	110	VGH
6	FPC R_OUT	41	IM<3>	76	AVDD	111	VGH
7	FPC R_IN	42	DB<0>	77	AVDD	112	VCOM
8	DUMMY	43	DB<1>	78	C31M	113	VCOM
9	VCOM	44	DB<2>	79	C31M	114	VCOM
10	VCOM	45	DB<3>	80	C31P	115	DUMMY
11	VCOM	46	DB<4>	81	C31P	116	FPC R_OUT
12	CONTACT2	47	DB<5>	82	C12M	117	FPC R_IN
13	CONTACT1	48	DB<6>	83	C12M	118	VCOM
14	VCOMR	49	DB<7>	84	C12P	119	VCOM
15	VCOML	50	DB<8>	85	C12P	120	VCOM
16	VCOMH	51	DB<9>	86	C11M	121	DUMMY
17	GVDDO	52	DB<10>	87	C11M	122	DUMMY
18	GVDDO	53	DB<11>	88	C11M		
19	VREF	54	DB<12>	89	C11P		
20	VDD3	55	DB<13>	90	C11P		
21	VDD3	56	DB<14>	91	C11P		
22	VDD3	57	DB<15>	92	VCI1		
23	VDD	58	DB<16>	93	VCI1		
24	VDD	59	DB<17>	94	VCI1		
25	VDD	60	RW_WRB	95	VSSC		
26	RVDD	61	E_RDB	96	VSSC		
27	RVDD	62	SDI	97	VSSC		
28	RVDD	63	RESETB	98	C21M		
29	VGS	64	ENABLE	99	C21M		
30	VSS	65	DOTCLK	100	C21P		
31	VSS	66	HSYNC	101	C21P		
32	AVSS	67	VSYNC	102	C22M		
33	AVSS	68	CSB	103	C22M		
34	CL1	69	RS	104	C22P		
35	FLM	70	VCL	105	C22P		

	I	Page No.	8/26
Document No.	DC170-004947	Revision	1.0

3.2 TFT Design Rules

Item		Specification	unit
COG ILITEK ILI9225B or compatible	Chip size	13.88 x 0.70	mm
	Pad number	528 x 220	~
	Pin assignment	<u>Based on the ILI9225B Spec.</u>	

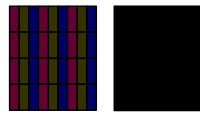
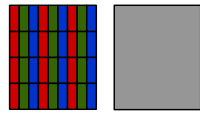
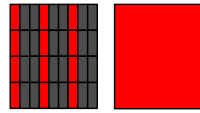
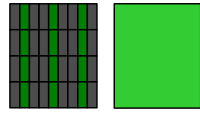
3.3 Cell test light on waveform

Display	Vdata	Pattern
Black	TSR = 0V and 11V TSG = 0V and 11V TSB = 0V and 11V	
Gray	TSR = 0V and 6V TSG = 0V and 6V TSB = 0V and 6V	
Red	TSR = 5V and 6V TSG = 0V and 11V TSB = 0V and 11V	
Green	TSR = 0V and 11V TSG = 5V and 6V TSB = 0V and 11V	
Blue	TSR = 0V and 11V TSG = 0V and 11V TSB = 5V and 6V	

	I	Page No.	9/26
Document No.	DC170-004947	Revision	1.0

Testing Waveform-

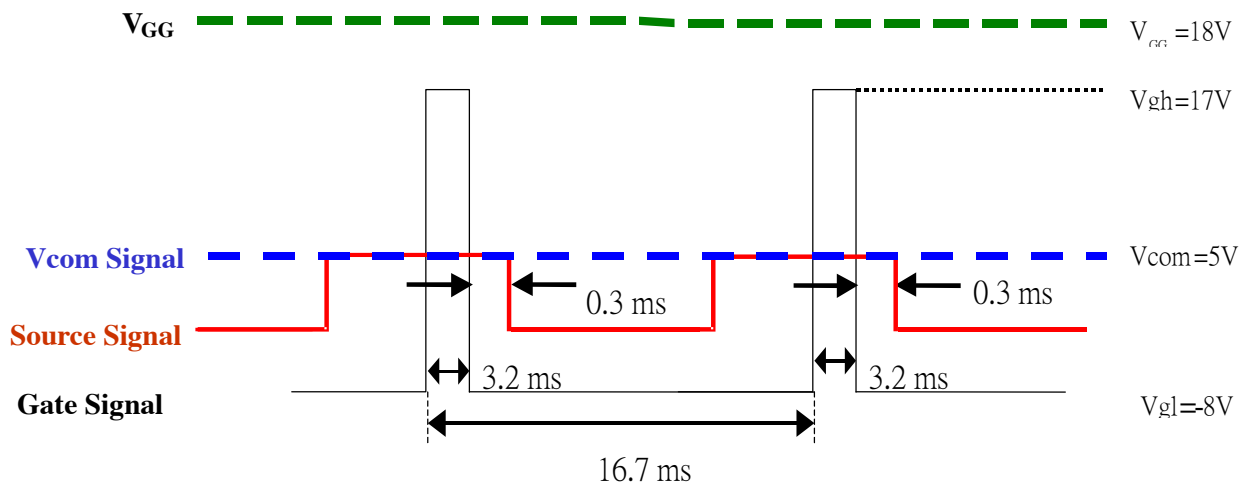

V_{data} = 0V and 5V

	I	Page No.	10/26
Document No.	DC170-004947	Revision	1.0

4.0 OPTICAL CHARACTERISTICS

4.1 Optical specification

Item	Symbol	Condition	Min.	Typ.	Max.	Unit	Note	
Transmittance (without Polarizer)	T(%)	—	—	15.7	—	—		
Contrast Ratio	CR	$\theta=0$	400	500	—	—	(1)(2)	
Response time	Rising	T_R	Normal viewing angle	—	2	4	msec	(1)(3)
	Falling	T_F		—	6	12		
Color gamut	S(%)			60		%		
Color chromaticity (CIE1931)	White	W_x		0.283	0.303	0.323	(1)(4) CF glass	
		W_y		0.305	0.325	0.345		
	Red	R_x		0.606	0.626	0.646		
		R_y		0.314	0.334	0.354		
	Green	G_x		0.257	0.277	0.297		
		G_y		0.529	0.549	0.569		
Blue	B_x		0.122	0.142	0.162			
	B_y		0.102	0.122	0.142			
Viewing angle	Hor.	θ_L	CR>10	35	45	—		
		θ_R		35	45	—		
	Ver.	θ_U		35	45	—		
		θ_D		10	20	—		
Optima View Direction	12 O'clock						(5)	

4.2 Measuring Condition

- Measuring surrounding : dark room
- Ambient temperature : $25\pm 2^\circ\text{C}$
- 15min. warm-up time.

4.3 Measuring Equipment

- FPM520 of Westar Display technologies, INC., which utilized SR-3 for Chromaticity and BM-5A for other optical characteristics.

	I	Page No.	11/26
Document No.	DC170-004947	Revision	1.0

Note (1) Definition of Viewing Angle :

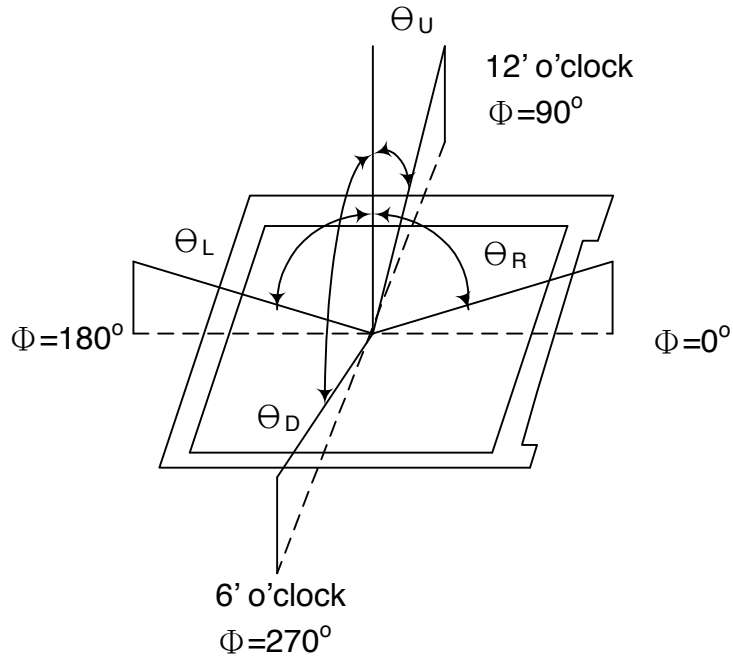

Note (2) Definition of Contrast Ratio(CR) :
measured at the center point of panel

$$CR = \frac{\text{Luminance with all pixels white}}{\text{Luminance with all pixels black}}$$

	I	Page No.	12/26
Document No.	DC170-004947	Revision	1.0

Note (3) Definition of Response Time : Sum of T_R and T_F

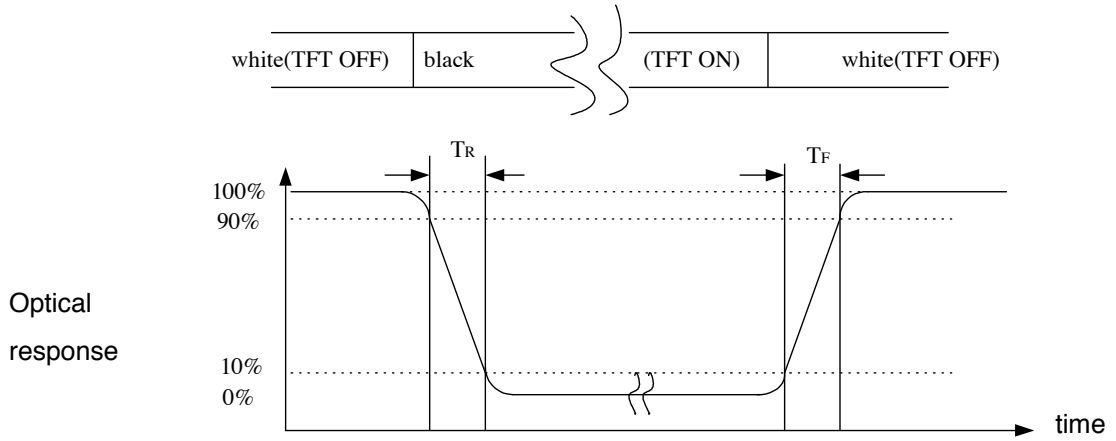

Note (4) Definition of optical measurement setup

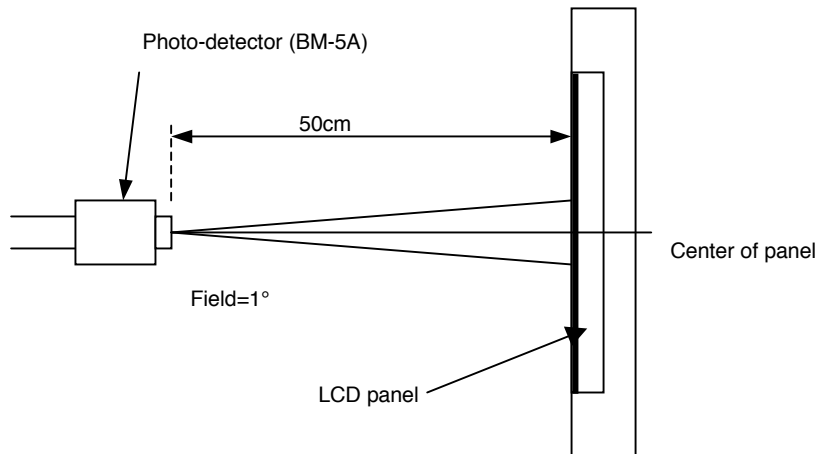

Note (5) Rubbing Direction (The different Rubbing Direction will cause the different optima view direction.)

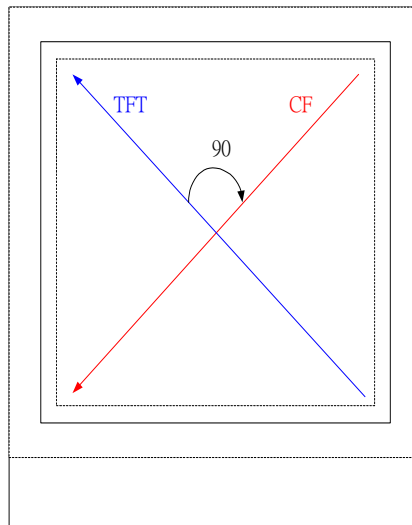

TFT Face up

	I	Page No.	13/26
Document No.	DC170-004947	Revision	1.0

5.0 Pixel Format

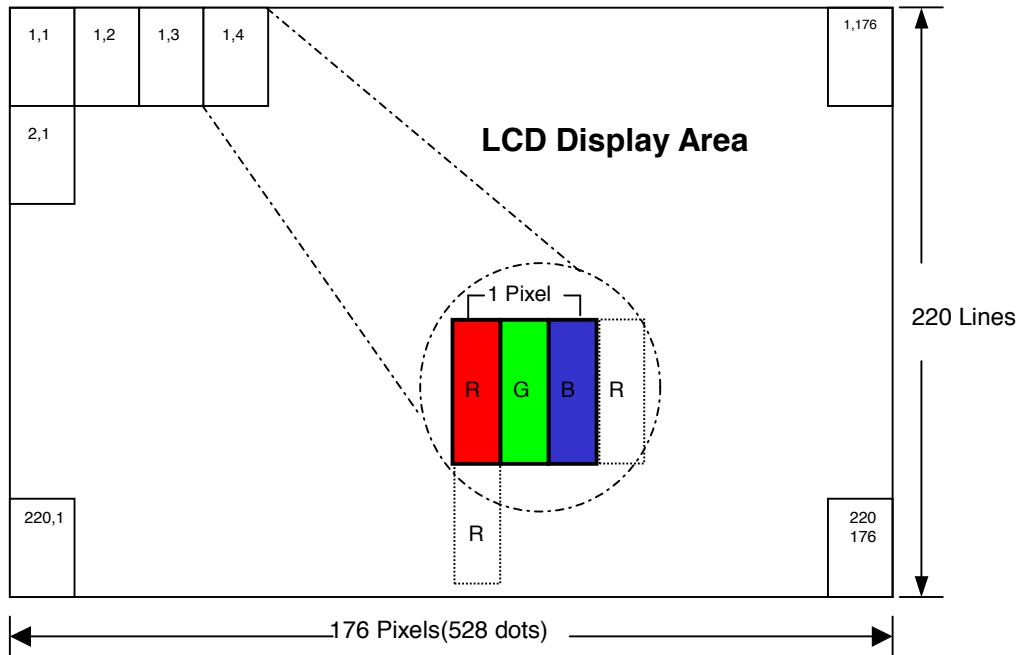

		I	Page No.	14/26
Document No.	DC170-004947		Revision	1.0

6.0 OUTLINE DIMENSION

6.1 Outline Dimension of Mother Glass For TFT film up

Unit : mm

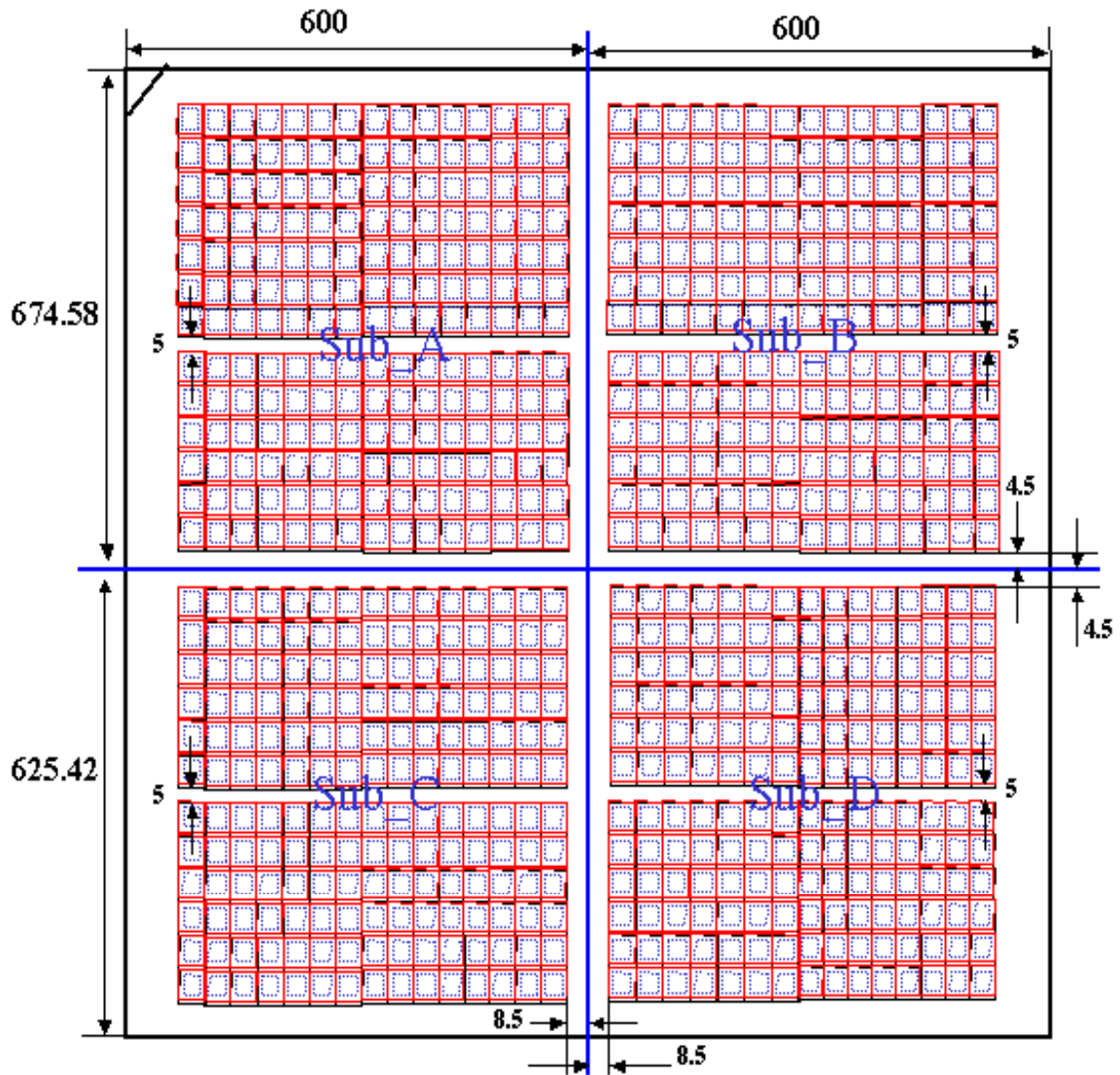

	I	Page No.	15/26
Document No.	DC170-004947	Revision	1.0

6.2 Chip Cut Mark Position Sub A/B/C/D Array Film Up

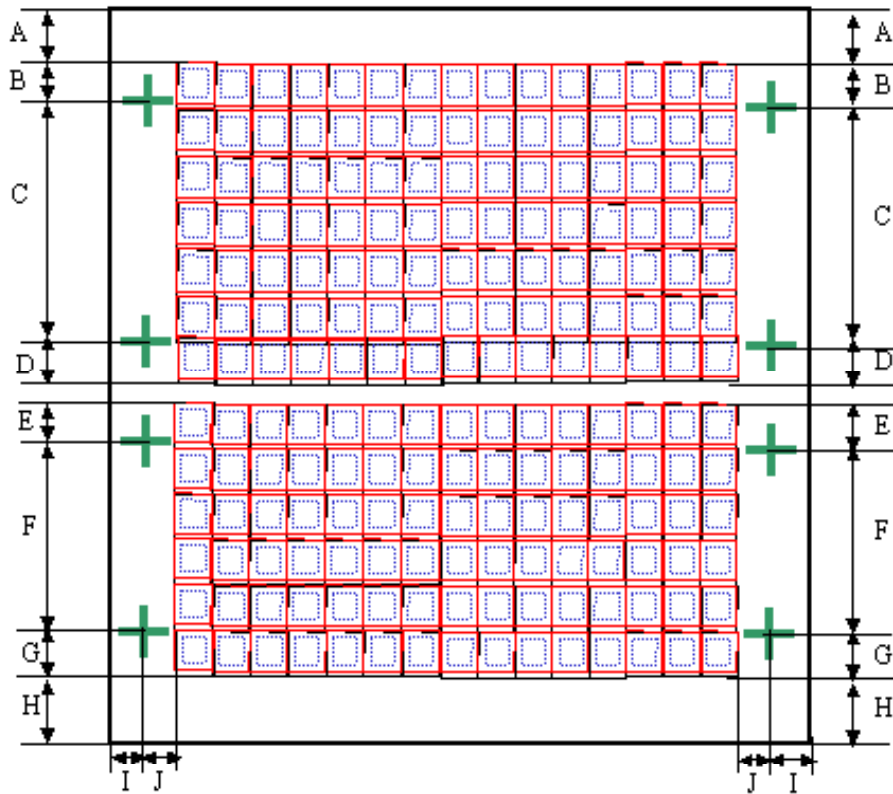

	Sub A	Sub B	Sub C	Sub D
A	13	13	4.5	4.5
B	4.5	4.5	4.5	4.5
C	343.12	343.12	292.96	292.96
D	3.5	3.5	3.5	3.5
E	4.5	4.5	4.5	4.5
F	292.96	292.96	292.96	292.96
G	3.5	3.5	3.5	3.5
H	4.5	4.5	14	14
I	16.28	16.28	16.28	16.28
J	4.5	4.5	4.5	4.5

	I	Page No.	16/26
Document No.	DC170-004947	Revision	1.0

6.3 Chip Size

6.3.1 HSD022F2N6-A00

Unit : mm

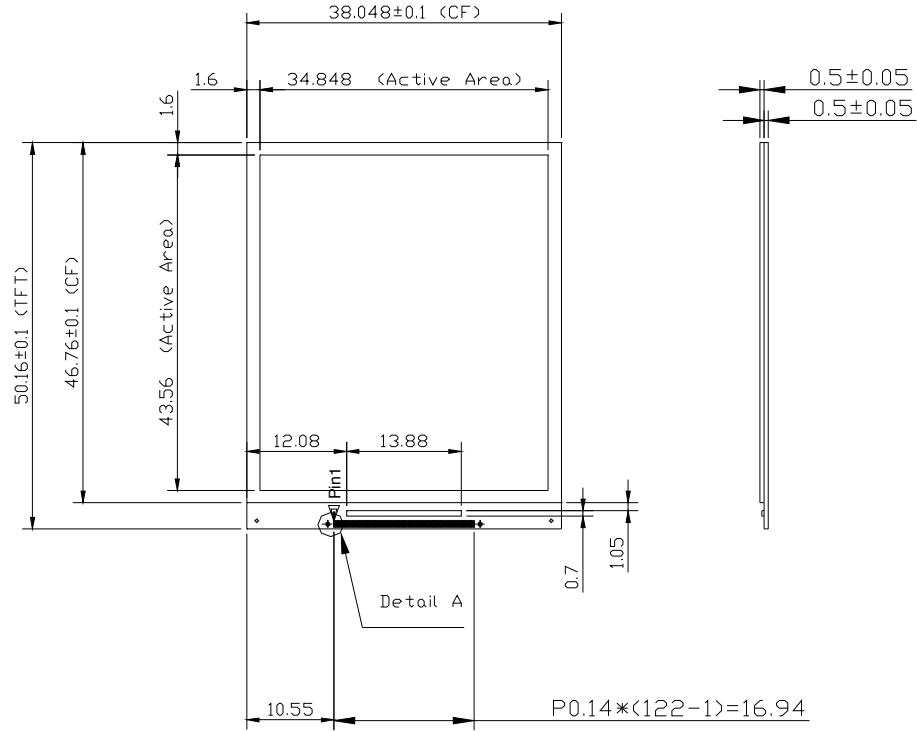

Notes :

1. General Tolerance: ± 0.2
2. FPC Pad Tolerance: ± 0.02

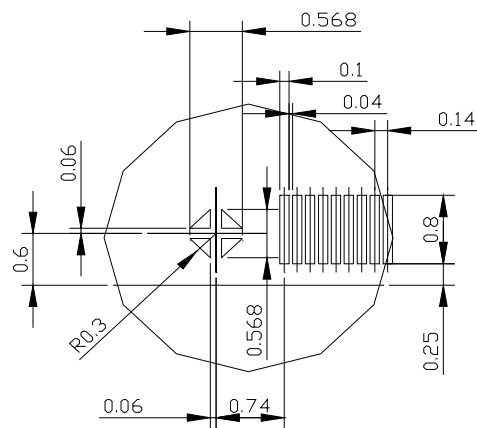

Detail "A" (S=10/1)

	I	Page No.	18/26
Document No.	DC170-004947	Revision	1.0

6.4 Driver IC Block Position

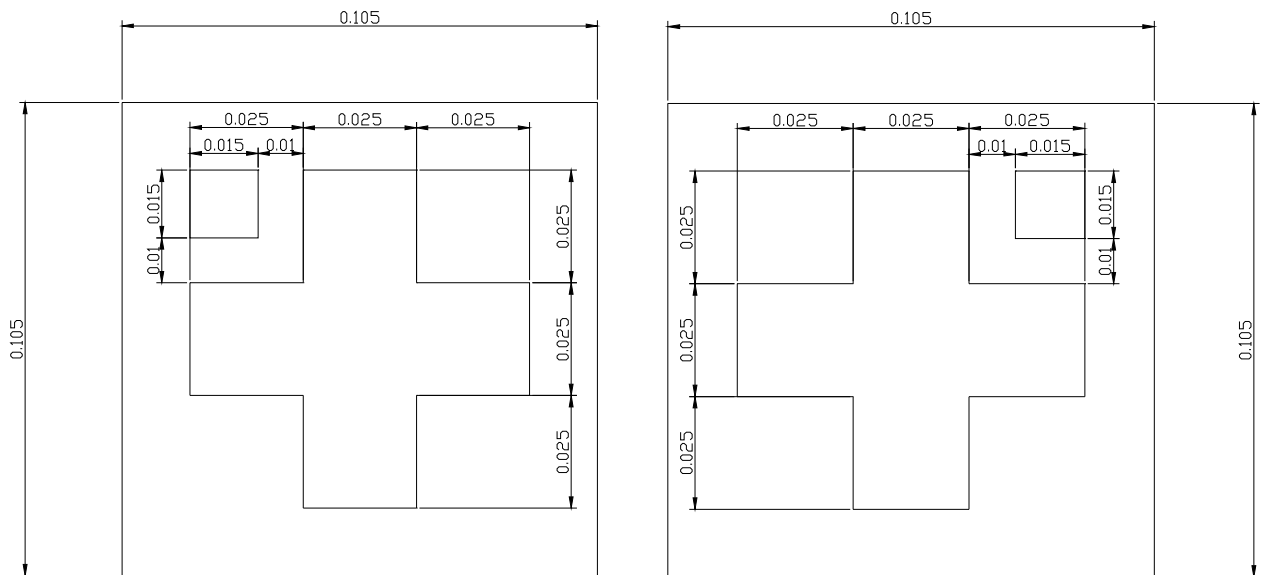
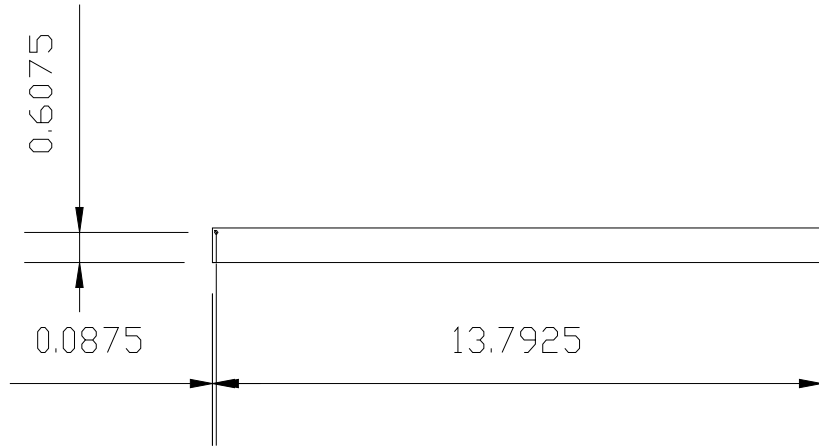

	I	Page No.	19/26
Document No.	DC170-004947	Revision	1.0

6.5 Test Pad Position

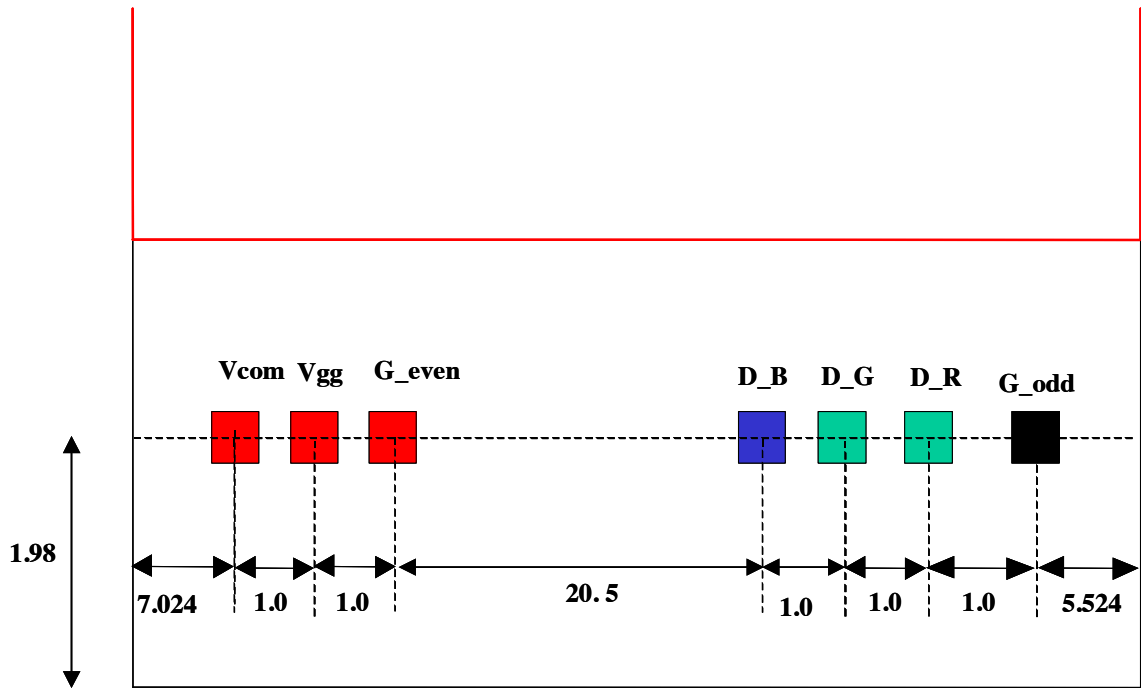

Pad size : 0.8 x 0.8

Unit : mm

	I	Page No.	20/26
Document No.	DC170-004947	Revision	1.0

7.0 Reliability test items

No.	Item	Conditions	Remark
1	High Temperature Storage	Ta=+80°C, 240hrs	
2	Low Temperature Storage	Ta=-30°C, 240hrs	
3	High Temperature Operation	Ta=+70°C, 240hrs	
4	Low Temperature Operation	Ta=-20°C, 240hrs	
5	High Temperature and High Humidity (Operating)	Ta=+60°C, 90%RH, 240hrs	

Note: (1) All tests above are practiced at module type.

(2) There is no display function NG issue occurred, all the cosmetic specification is judged before the reliability stress.

	I	Page No.	21/26
Document No.	DC170-004947	Revision	1.0

8.0 LOT MARK



8.1 Lot Mark

(1) Cell Type: Production name

1	2	3	4	5	6	7	8	9	10	11	12
H	S	D	0	2	2	B	2	N	6	-	A

code 1~3: Hannstar Display Co.

code 4~6: Display Area Diagonal size(inch)

011=1.1"

015=1.5"

018=1.8",.....

code 7 : Shipment type

A= Full Size before 2nd cut

B= 1/4 Cut

D= 1/16 Cut

F= Full cell without Polarizer

G= Full cell with Polarizer+IC

code 8 : Resolution

1=QQVGA ; 2=QCIF+ ; 3=QVGA ; 4=QQVGA- ; 5=960x234 ;

6=480x234/480x240 ; 9=480x272 ; A=240x400/240x432 ;

C=640x234; D=800x480 ; E=SXGA ; F=1024x576/1024x600 ;

G=WXGA+; H=HDTV ; J=720x480; K=WSXGA+ ; S=SVGA ;

X=XGA ; U=WUXGA/FHD ; V=VGA ; W=WXGA ;

code 9 : Aspect ratio

N=Standard , W=Wide

code10 :Serial No.

code12 :Version No.

	I	Page No.	22/26
Document No.	DC170-004947	Revision	1.0

(2) Production date and location

(3) Label ID: serial number for barcode.

(1)	(2)	(3)	(4)	(5)	(6)	(7)	(8)	(9)	(10)
-----	-----	-----	-----	-----	-----	-----	-----	-----	------

Code (1),(2) : Out source code

Code (3) : Grade (D)

Code (4) : Year

Year	2003	2004	2005	2006	2007	2008	2009	2010	2011	2012
Mark	3	4	5	6	7	8	9	0	1	2

Code (5) : Month

Month	Jan.	Feb.	Mar.	Apr.	May.	Jun.	Jul.	Aug.	Sep.	Oct	Nov.	Dec.
Mark	1	2	3	4	5	6	7	8	9	A	B	C

Code (6) : Date (1~9, A~X exp.I/O:10~31)

Code (7),(8),(9),(10) : Serial No.

(4) P/N: Hannstar internal part number

(5) QTY: Quantity of chip

	I	Page No.	23/26
Document No.	DC170-004947	Revision	1.0

9.0 PACKAGE SPECIFICATION

9.1 Packing form

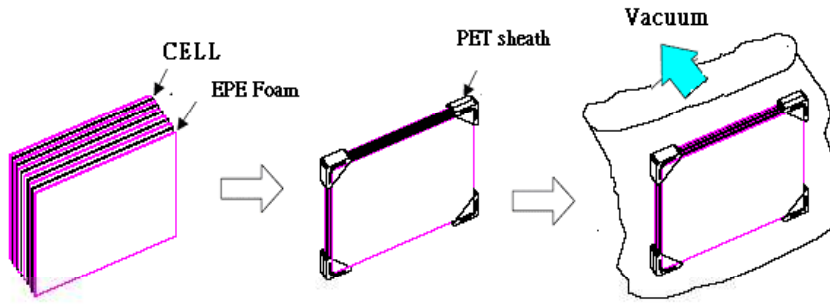

5 sheets x 6packs=30 sheets

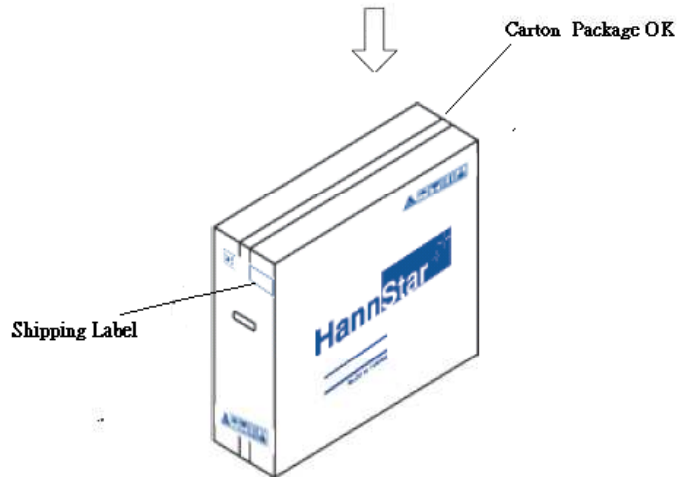

	I	Page No.	24/26
Document No.	DC170-004947	Revision	1.0

9.2 Packing assembly drawings

9.2.1 Sub A/Sub B : 885*120*1000 mm

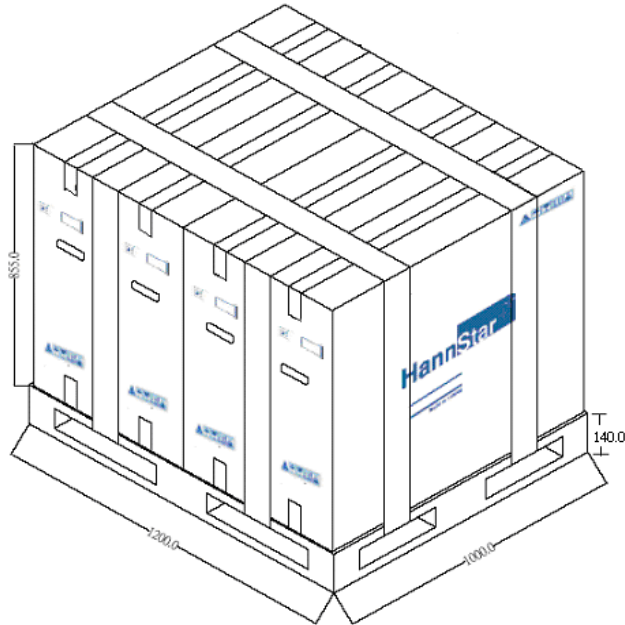

Notes:
 1 Pallet: 4 set Cartons
 1 Pallet: 120 sheet Cells

9.2.2 Sub C/Sub D : 880*120*1000 mm

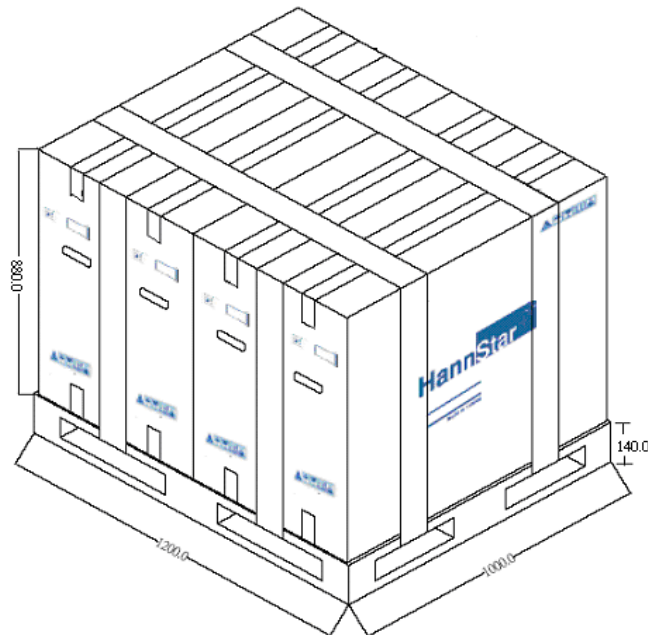

Notes:
 1 Pallet: 4 set Cartons
 1 Pallet: 120 sheet Cells

	I	Page No.	25/26
Document No.	DC170-004947	Revision	1.0

10.0 GENERAL PRECAUTION

10.1 Use Restriction

This product is not authorized for use in life supporting systems, aircraft navigation control systems, military systems and any other application where performance failure could be life-threatening or otherwise catastrophic.

10.2 Disassembling or Modification

Do not disassemble or modify the LCD. It may damage sensitive parts inside LCD, and may cause scratches or dust on the display. HannStar does not warrant the LCD, if customers disassemble or modify the module.

10.3 Breakage of LCD Panel

- 10.3.1 If LCD panel is broken and liquid crystal spills out, do not ingest or inhale liquid crystal, and do not contact liquid crystal with skin.
- 10.3.2 If liquid crystal contacts mouth or eyes, rinse out with water immediately.
- 10.3.4 If liquid crystal contacts skin or cloths, wash it off immediately with alcohol and rinse thoroughly with water.
- 10.3.4 Handle carefully with chips of glass that may cause injury, when the glass is broken.

10.4 Absolute Maximum Ratings and Power Protection Circuit

- 10.4.1 Do not exceed the absolute maximum rating values, such as the supply voltage variation, input voltage variation, variation in parts' parameters, environmental temperature, etc., otherwise LCD may be damaged.
- 10.4.2 Please do not leave LCD in the environment of high humidity and high temperature for a long time.
- 10.4.3 It's recommended to employ protection circuit for power supply.

10.5 Operation

- 10.5.1 Do not touch, push or rub the polarizer with anything harder than HB pencil lead If the LCD attaches a polarizer.
- 10.5.2 Use fingerstalls of soft gloves in order to keep clean display quality, when persons handle the LCD for incoming inspection or assembly.
- 10.5.3 When the surface is dusty, please wipe gently with absorbent cotton or other softmaterial.
- 10.5.4 Wipe off saliva or water drops as soon as possible. If saliva or water drops contactwith polarizer for a long time, they may causes deformation or color fading.
- 10.5.5 When cleaning the adhesives, please use absorbent cotton wetted with a little petroleum benzine or other adequate solvent.

	I	Page No.	26/26
Document No.	DC170-004947	Revision	1.0

10.6 Static Electricity

- 10.6.1 Protection film must remove very slowly from the surface of LCD to prevent from electrostatic occurrence if the LCD attaches a polarizer.
- 10.6.2 Because TFT-LCD panel is very weak to electrostatic discharge, please be careful with electrostatic discharge.
- 10.6.3 Persons who handle the LCD should be grounded through adequate methods.

10.7 Strong Light Exposure

The LCD shall not be exposed under strong light such as direct sunlight. Otherwise display characteristics may be changed.

10.8 Disposal

When disposing LCD, obey the local environmental regulations.