



Document Title	HSD090IF41-A Product Information	Page No.	1/27
Document No.		Revision	1.0

TO :

Date : Aug.11, 2005

## HannStar Product Information

### 9 " color TFT-LCD module

Model Name : HSD090IF41

-A\*\*

- Note:1. Please contact HannStar Display Corp. before designing your product based on this module specification.
2. The information contained herein is presented merely to indicate the characteristics and performance of our products. No responsibility is assumed by HannStar for any intellectual property claims or other problems that may result from application based on the module described herein.
  - 3.The mark “ \*\* ” of Model means sub-model code.



Document Title	HSD090IF41-A Product Information	Page No.	2/27
Document No.		Revision	1.0

### Record of Revisions

Rev.	Date	Sub-Model	Description of change
1.0	Aug. 22, 2005	A00	HSD090IF41 Product Information was first issued.



Document Title	HSD090IF41-A Product Information	Page No.	3/27
Document No.		Revision	1.0

## Contents

1.0	General description .....	p.4
2.0	Absolute maximum ratings .....	p.6
3.0	Optical characteristics .....	p.7
4.0	Block diagram .....	p.11
5.0	Interface pin connection .....	p.12
6.0	Electrical characteristics .....	p.15
7.0	Reliability test items.....	p.21
8.0	Outline dimension .....	p.22
9.0	Lot mark .....	p.24
10.0	Package specification .....	p.25
11.0	General precaution .....	p.26

Document Title	HSD090IF41-A Product Information	Page No.	4/27
Document No.		Revision	1.0

## 1.0 GENERAL DESCRIPTION

### 1.1 Introduction

HannStar Display model HSD090IF41-A is a color active matrix thin film transistor (TFT) liquid crystal display (LCD) that uses amorphous silicon TFT as a switching device. This model is composed of a TFT LCD panel, a driving circuit and a back light system. This TFT LCD has a 9.0 inch diagonally measured active display area with WVGA resolution (480 vertical by 800RGB horizontal pixel array).

### 1.2 Features

- 9.0 inch (16:9 diagonal) WVGA configuration
- 6 Bits color driver with 1 channel TTL interface (30 pin x 2)

### 1.3 Applications

- Portable TV
- Portable DVD
- Multimedia applications and Others AV system

### 1.4 General information

Item	Specification	Unit
Outline Dimension	211.4 x 131.7 x 6.1 (Typ.)	mm
Display area	196.8(H) x 116.88(V)	mm
Number of Pixel	800RGB(H) x 480(V)	pixels
Pixel pitch	0.246(H) x 0.2435(V)	mm
Pixel arrangement	RGB Vertical stripe	
Display mode	Normally white	
Surface treatment	Antiglare, Hard-Coating(3H) with WV film	
Weight	273 (Typ.)	g
Back-light	Single CCFL (L type Side-Light)	



Document Title	HSD090IF41-A Product Information	Page No.	5/27
Document No.		Revision	1.0

**1.5 Mechanical Information**

	Item	Min.	Typ.	Max.	Unit
Module Size	Horizontal(H)	211.1	211.4	211.7	mm
	Vertical(V)	131.4	131.7	132.0	mm
	Depth(D)	—	6.1	6.4	mm
Weight (Without inverter)		—	273	283	g

Document Title	HSD090IF41-A Product Information	Page No.	6/27
Document No.		Revision	1.0

## 2.0 ABSOLUTE MAXIMUM RATINGS

### 2.1 Electrical Absolute Rating

#### 2.1.1 TFT LCD Module

Item	Symbol	Min.	Max.	Unit	Note
Power supply voltage	$V_{DD}$	-0.5	5.5	V	GND=0
	$V_{GH}$	-0.3	40	V	GND=0
	$V_{GL}$	-20	0.3	V	GND=0
	$AV_{DD}$	-0.5	12	V	AGND=0
Input Signal voltage	$V_I$	-0.5	$V_{DD} + 0.5$	V	
	$V_{GMA(1\sim7)}$	$0.4AV_{CC}$	$AV_{DD} + 0.3$	V	
	$V_{GMA(8\sim14)}$	-0.3	$0.6AV_{DD}$	V	

#### 2.1.2 Back-Light Unit

Item	Symbol	Min.	Max.	Unit	Note
Lamp current	$I_L$	5.0	6.0	mA	
Lamp frequency	$f_L$	29	32	KHz	

### 2.2 Environment Absolute Rating

Item	Symbol	Min.	Max.	Unit	Note
Operating Temperature	Topa	-10	60	°C	
Storage Temperature	Tstg	-20	70	°C	

Document Title	HSD090IF41-A Product Information	Page No.	7/27
Document No.		Revision	1.0

### 3.0 OPTICAL CHARACTERISTICS

#### 3.1 Optical specification

Item		Symbol	Condition	Min.	Typ.	Max.	Unit	Note	
Contrast		CR	$\theta = 0$ Normal viewing angle	320	400	—		(1)(2)(4)(6)	
Response time	Rising	$T_R$		—	5	10	msec	(1)(3)(4)(6)	
	Falling	$T_F$		—	20	25			
White luminance (Center)		$Y_L$			300	350	—	cd/m <sup>2</sup>	(1)(4)(7) ( $I_L=6.0mA$ )
Color chromaticity (CIE1931)	White	$W_x$			0.266	0.313	0.366		(1)(4)(7)
		$W_y$		0.279	0.329	0.379			
Viewing angle	Hor.	$\theta_L$	CR>10	50	60	—		(1)(4)(6)	
		$\theta_R$		50	60	—			
	Ver.	$\theta_U$		30	40	—			
		$\theta_D$		50	60	—			
Brightness uniformity		$B_{UNI}$	$\theta = 0$	70	—	—	%	(5)	

#### 3.2 Measuring Condition

- Measuring surrounding : dark room
- Lamp current  $I_{FL}$  :  $6.0 \pm 0.1mA(rms)$ , Lamp freq.  $F_L=32KHz$ , Inverter : HIU-766
- Ambient temperature :  $25 \pm 2^\circ C$
- 30min. warm-up time.

Document Title	HSD090IF41-A Product Information	Page No.	8/27
Document No.		Revision	1.0

### 3.3 Measuring Equipment

- Otsuka Electrics Corp., which utilized LCD-7000 for Chromaticity and BM-5 for other optical characteristics.
- Measuring spot size : 10 ~ 12 mm

**Note (1)** Definition of Viewing Angle :

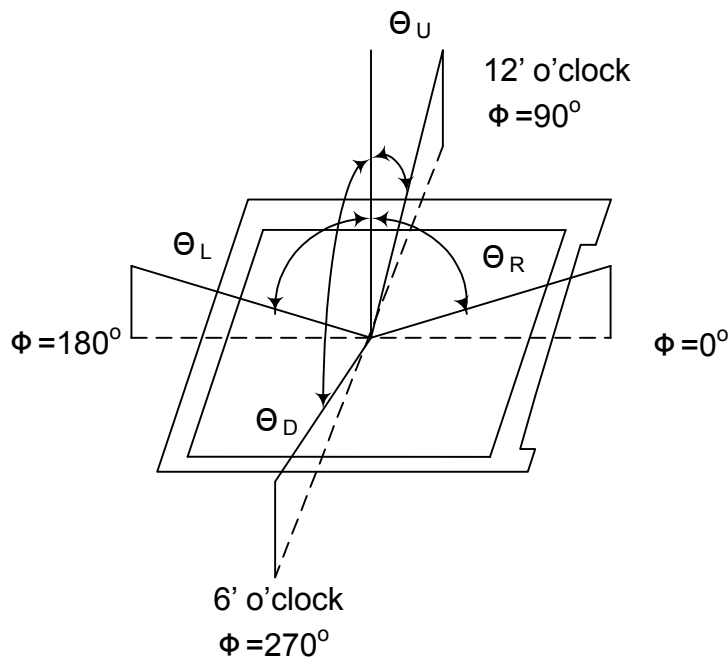

**Note (2)** Definition of Contrast Ratio(CR) :  
measured at the center point of panel

$$CR = \frac{\text{Luminance with all pixels white}}{\text{Luminance with all pixels black}}$$



Document Title	HSD090IF41-A Product Information	Page No.	9/27
Document No.		Revision	1.0

**Note (3)** Definition of Response Time : Sum of  $T_R$  and  $T_F$

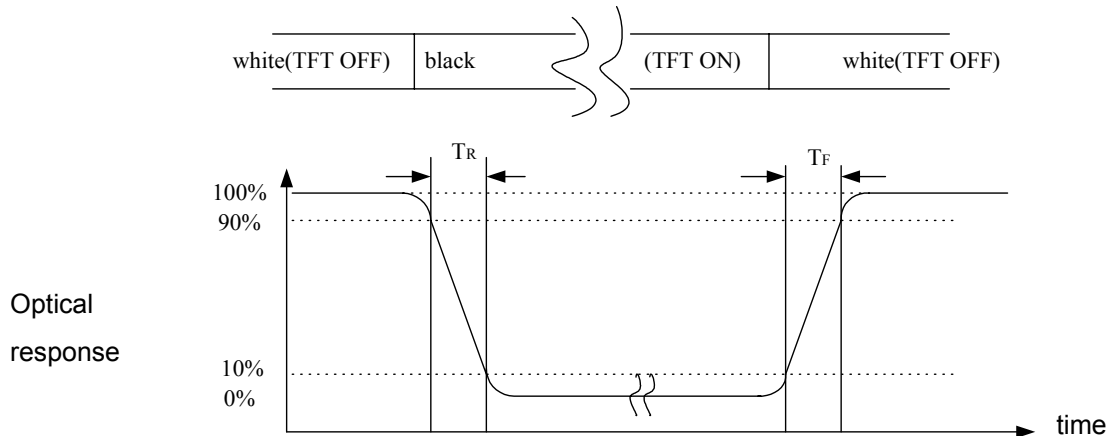

**Note (4)** Definition of optical measurement setup

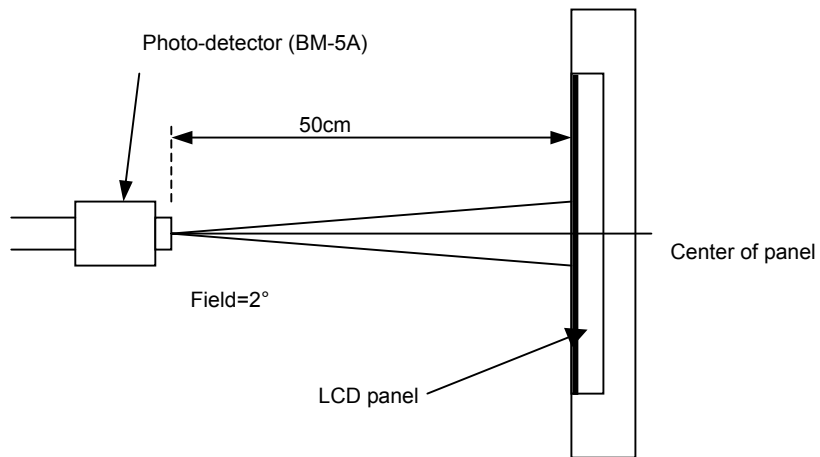

Document Title	HSD090IF41-A Product Information	Page No.	10/27
Document No.		Revision	1.0

**Note (5)** Definition of brightness uniformity

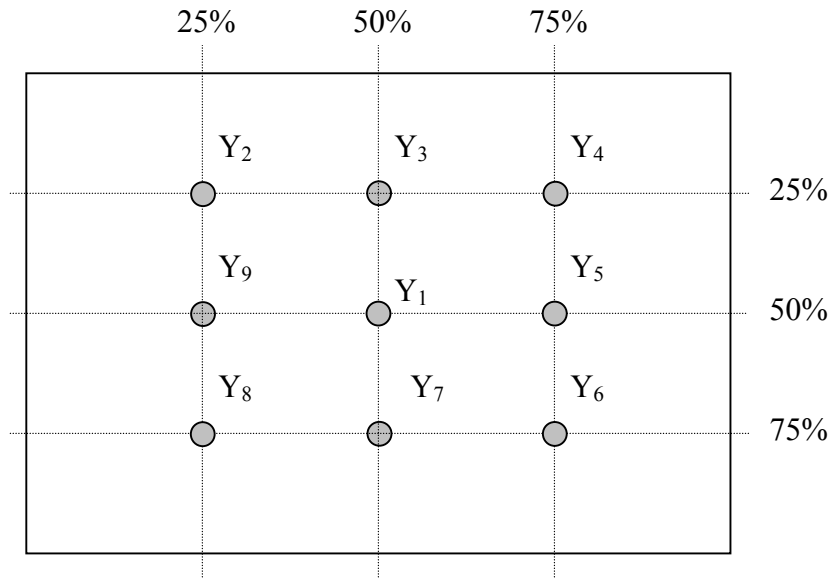

$$\text{Luminance uniformity} = \frac{(\text{Min Luminance of 9 points})}{(\text{Max Luminance of 9 points})} \times 100\%$$

**Note (6)** Definition of viewing angle, Refer to figure as below

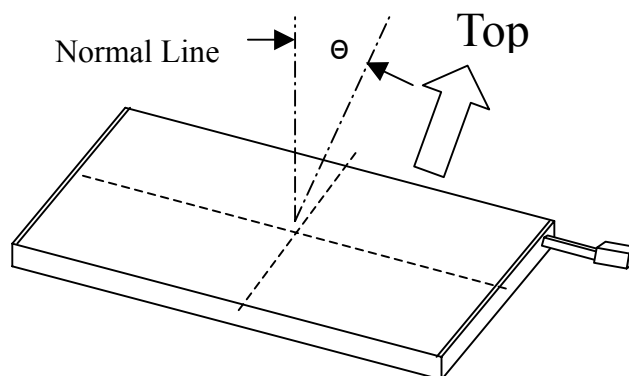

**Note (7)** Measurement at the center area of the panel when all the input terminals of LCD panel are electrically opened

Document Title	HSD090IF41-A Product Information	Page No.	11/27
Document No.		Revision	1.0

## 4.0 BLOCK DIAGRAM

### 4.1 TFT LCD Module

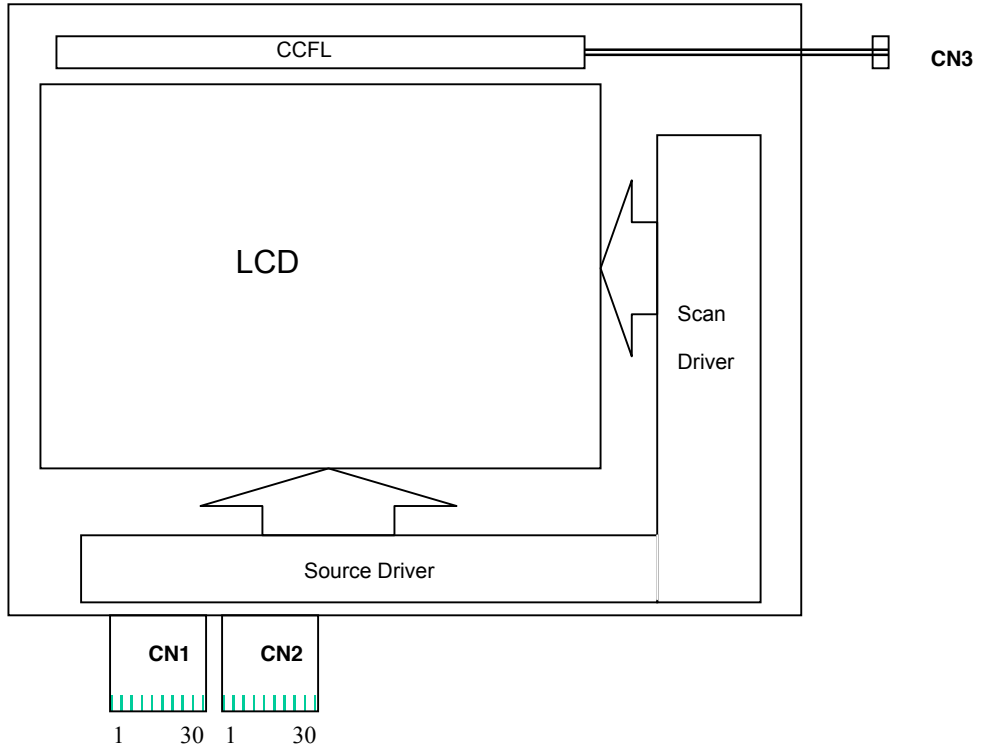

### 4.2 Pixel Format

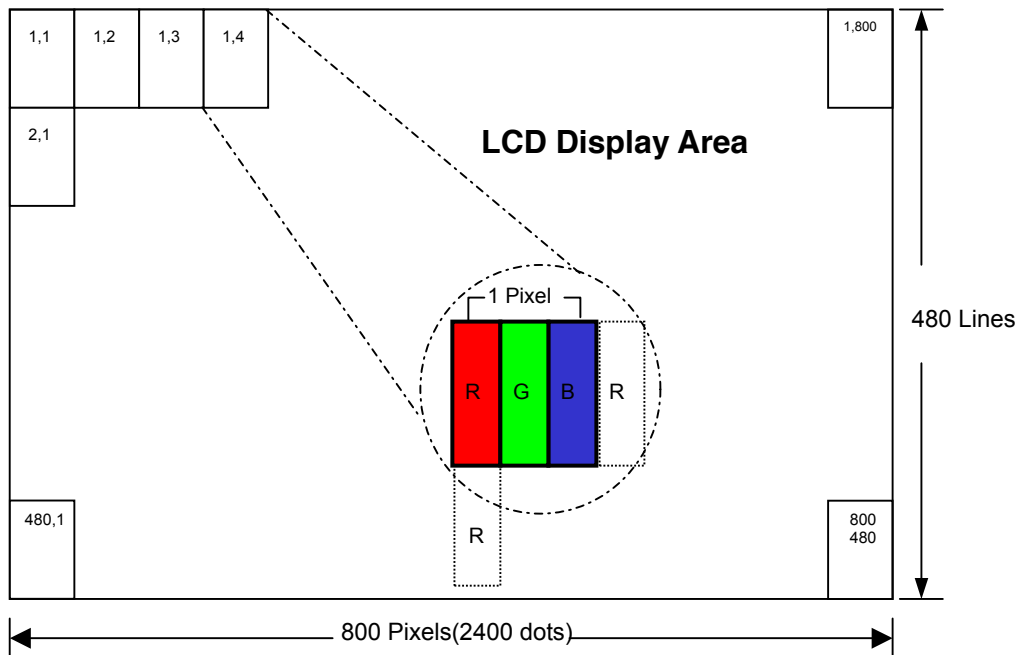

Document Title	HSD090IF41-A Product Information	Page No.	12/27
Document No.		Revision	1.0

## 5.0 INTERFACE PIN CONNECTION

### 5.1 TFT LCD Module

**CN1 & CN2** (Input signal): FPC Down Connector, 30 pins, pitch: 0.5mm:

**CN1:**

Terminal no.	Symbol	I/O	Function	Note
1	POL	I	Polarity Setting	
2	STVD	I/O	Vertical Line start pulse I/O signal	
3	OEV	O	Vertical Line output Enable signal	
4	CPV	I	Vertical Line Clock	
5	STVU	I/O	Vertical Line start pulse I/O signal	
6	GND	-	Digital Power Ground	
7	EDGSEL	I	Rising/Falling Selection	
8	VDD	-	Digital Voltage Input	
9	VGMA_12	I	Gamma Voltage Input	
10	VGL	-	GateOFF Voltage	
11	VGMA_14	I	Gamma Voltage Input	
12	VGH	-	GateON Voltage	
13	VGMA_13	I	Gamma Voltage Input	
14	U/D SEL	I	Vertical Scanning Line Direction Selection	
15	VCOM1	-	Common Voltage	
16	AGND	-	Analog Power Ground	
17	AVDD	-	Analog Voltage Input	
18	VGMA_10	I	Gamma Voltage Input	
19	VGMA_8	I	Gamma Voltage Input	
20	VGMA_6	I	Gamma Voltage Input	
21	VGMA_4	I	Gamma Voltage Input	
22	VGMA_2	I	Gamma Voltage Input	
23	GND	-	Digital Power Ground	
24	R5	I	Red Data Bus Input ( MSB )	
25	R4	I	Red Data Bus Input	
26	R3	I	Red Data Bus Input	
27	R2	I	Red Data Bus Input	
28	R1	I	Red Data Bus Input	
29	R0	I	Red Data Bus Input ( LSB )	
30	GND	-	Digital Power Ground	

Document Title	HSD090IF41-A Product Information	Page No.	13/27
Document No.		Revision	1.0

**CN2**

Terminal no.	Symbol	I/O	Function	Note
31	GND	-	Digital Power Ground	
32	G5	I	Green Data Bus Input ( MSB )	
33	G4	I	Green Data Bus Input	
34	G3	I	Green Data Bus Input	
35	G2	I	Green Data Bus Input	
36	G1	I	Green Data Bus Input	
37	G0	I	Green Data Bus Input ( LSB )	
38	STHR (DIO1)	I/O	Horizontal Line start pulse I/O signal	
39	INV	I	Data Invert signal	
40	GND	-	Digital Power Ground	
41	DCLK	I	Pixel clock	
42	VDD	-	Digital Voltage Input	
43	STHL (DIO2)	I	Horizontal Line start pulse I/O signal	
44	LOAD	O	Polarity latch and reflash new data to output	
45	B5	I	Blue Data Bus Input ( MSB )	
46	B4	I	Blue Data Bus Input	
47	B3	I	Blue Data Bus Input	
48	B2	I	Blue Data Bus Input	
49	B1	I	Blue Data Bus Input	
50	B0	I	Blue Data Bus Input ( LSB )	
51	R/L SEL	-	Horizontal Scanning Line direction Selection	
52	VGMA_1	I	Gamma Voltage Input	
53	VGMA_3	I	Gamma Voltage Input	
54	VGMA_5	I	Gamma Voltage Input	
55	VGMA_7	I	Gamma Voltage Input	
56	VGMA_9	I	Gamma Voltage Input	
57	VGMA_11	I	Gamma Voltage Input	
58	AVDD	-	Analog Voltage Input	
59	GND	-	Analog Power Ground	
60	VCOM1	-	Common Voltage	



Document Title	HSD090IF41-A Product Information	Page No.	14/27
Document No.		Revision	1.0

## 5.2 Back-Light Unit

**CN3** CCFL Power Source (**BHSR-02VS-1**) / JAPAN SOLDERLESS TERMINAL MFG CO., LTD.

Mating Connector: (**SBHT-002T-P0.5**) / JAPAN SOLDERLESS TERMINAL MFG CO., LTD.

Terminal no.	Symbol	Function
1	VL	CCFL power supply (high voltage)
2	GL	CCFL power supply (low voltage)

Document Title	HSD090IF41-A Product Information	Page No.	15/27
Document No.		Revision	1.0

## 6.0 ELECTRICAL CHARACTERISTICS

### 6.1 TFT LCD Module

#### DC Electrical Characteristics

Parameter	Symbol	Min	Typ.	Max.	Unit	Note
Supply Voltage	$V_{DD}$	3.0	3.3	3.6	V	
	$V_{GH}$	10.0	23.5	35	V	
	$V_{GL}$	-15	-8	-5	V	
	$V_{GH} - V_{GL}$	15.0	31.5	40.0	V	
	$V_{COM}$	3.25	3.75	4.25	V	
Low Level Input Voltage	$V_{il}$	Gnd	-	$0.3V_{DD}$	V	
High Level Input Voltage	$V_{ih}$	$0.7 V_{DD}$	-	$V_{DD}$	V	
High Level Output Voltage	$V_{oh}$	$V_{DD} - 0.4$	-	$V_{DD}$	V	
Low Level Output Voltage	$V_{ol}$	Gnd	-	$Gnd + 0.4$	V	
Sinking Current of Outputs	IOL	-80	-	-	uA	
Driving Current of Outputs	IOH	80	-	-	uA	
Supply Analog Voltage	$AV_{DD}$	6.5	9.0	10.0	V	
Input level V1 ~ V7	$V_{GMA} 1\sim 7$	$0.4AV_{DD}$	-	$AV_{DD} - 0.1$	V	(1)
Input level V8 ~ V14	$V_{GMA} 8\sim 14$	0.1	-	$0.6AV_{DD}$	V	(1)
Current for driver	$I_{GH}$	-	250	-	uA	$V_{GH}=23.5$
	$I_{GL}$	-	230	-	uA	$V_{GL}=-8$
	$I_{CC}$	-	10	-	mA	$V_{CC}=3.3$
	$I_{DD}$	-	46.7	-	mA	$AV_{DD}=9$

**Note(1)**  $AV_{DD} > V_{GMA} 1 > V_{GMA} 2 > V_{GMA} 3 > \dots \dots \dots V_{GMA} 12 > V_{GMA} 13 > V_{GMA} 14 > AV_{SS}$

Document Title	HSD090IF41-A Product Information	Page No.	16/27
Document No.		Revision	1.0

## 6.2 AC Characteristics

Parameter	Symbol	Min	Typ	Max	Unit
CLK frequency	Fclk	-	40	45	MHz
CLK pulse width	Tcw	8	-	-	ns
Data set up time	Tsu	4	-	-	ns
Data hold time	Thd	2	-	-	ns
Propagation delay of DIO2/1	Tphl	6	10	15	ns
Time that the last data to LD	Tld	1	-	-	Tcph
Pulse width of LD	Twld	2	-	-	Tcph
Time that LD to DIO1/2	Tlds	5	-	-	Tcph
POL set up time	Tpsu	6	-	-	ns
POL hold time	Tphd	6	-	-	ns
Output stable time	Tst	-	-	12	us
CKV pulse width	TCKV	5			us
OEV pulse width	TOEV	1			us
STV set up time	Tsuv	200			ns
STV hold time	Thdv	300			ns

( $V_{DD}=3.3V$ ,  $AV_{DD}=9.0V$ ,  $Gnd=0V$ ,  $Ta=25^{\circ}C$ )



Document Title	HSD090IF41-A Product Information	Page No.	17/27
Document No.		Revision	1.0

### 6.3 Back-Light Unit

The back-light system is an edge-lighting type with 1 CCFL(Cold Cathode Fluorescent Lamp). The characteristics of the lamp is shown in the following tables.

Item	Symbol	Min.	Typ.	Max.	Unit	Note
Lamp current	IL	5.0	6.0	7.0	mA(rms)	(1)(6)
Lamp voltage	VL	589	655	721	V(rms)	(6) $I_L=6.0mA$
Frequency	fL	29	32	35	KHz	(2)
Operating lamp life time	Hr	40,000	—	—	Hour	(3)
Startup voltage	Vs	960	—	—	V(rms)	(4)(5)at 25°C
		1248				(4)(5)at 0°C

Note (1) Lamp current is measured with current meter for high frequency as shown below. Specified valued are for single lamp.

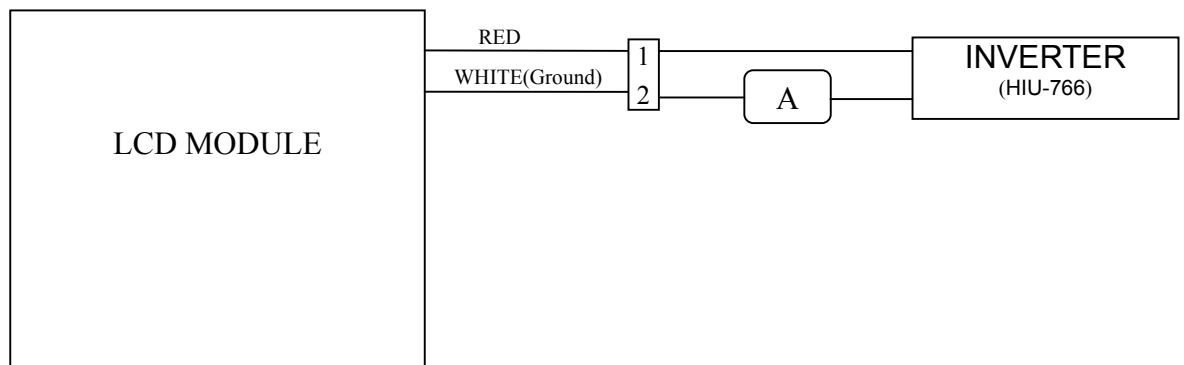

Note (2) Lamp frequency may produce interference with horizontal synchronous frequency and this may cause ripple noise on the display. Therefore lamp frequency shall be kept away from the horizontal synchronous frequency and its harmonics as far as possible in order to avoid interference.

Note (3) Lamp life time (Hr) can be defined as the time in which it continues to operate under the condition :  $T_a=25\pm 3^\circ C$ , typical IL value indicated in the above table and  $f_L=50kHz$  until the brightness becomes less than 50%.

Note (4) CCFL inverter should be able to provide a voltage over specified value (Vs) in the above table. Lamp units need at least Vs value shown above to ignition.

Document Title	HSD090IF41-A Product Information	Page No.	18/27
Document No.		Revision	1.0

Note (5) The voltage over specified value (Vs) should be applied to the lamp more than 1 second after startup. Otherwise, the lamp may not be turned on. The used lamp current is the lamp typical current.

Note (6) The output voltage waveform and current waveform of the inverter must be symmetrical (Unsymmetrical ratio is less than 10%). Please do not use the inverter which has unsymmetrical voltage and current waveform, and spike waveform. The inverter design which can provide the best optical performance, power efficiency, and lamp life should under the following conditions.

- a. The asymmetry rate of the inverter waveform should be less than 10%.
- b. The distortion rate of the waveform should be within  $\sqrt{2} \pm 10\%$ .
- c. The inverter output waveform should be better similar to the ideal sine wave.

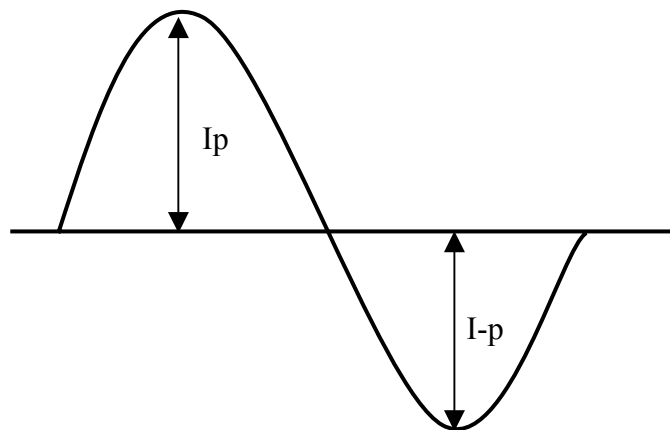

$$\text{Asymmetry rate} = \frac{|I_p - I_{-p}|}{I_{rms}} \times 100\%$$

$$\text{Distortion rate} = \frac{I_p \text{ (or } I_{-p})}{I_{rms}}$$

Document Title	HSD090IF41-A Product Information	Page No.	19/27
Document No.		Revision	1.0

### 6.4 Timing Diagram of Interface Signal

■ Timing Diagram 1 ( MODE="1" , Default )

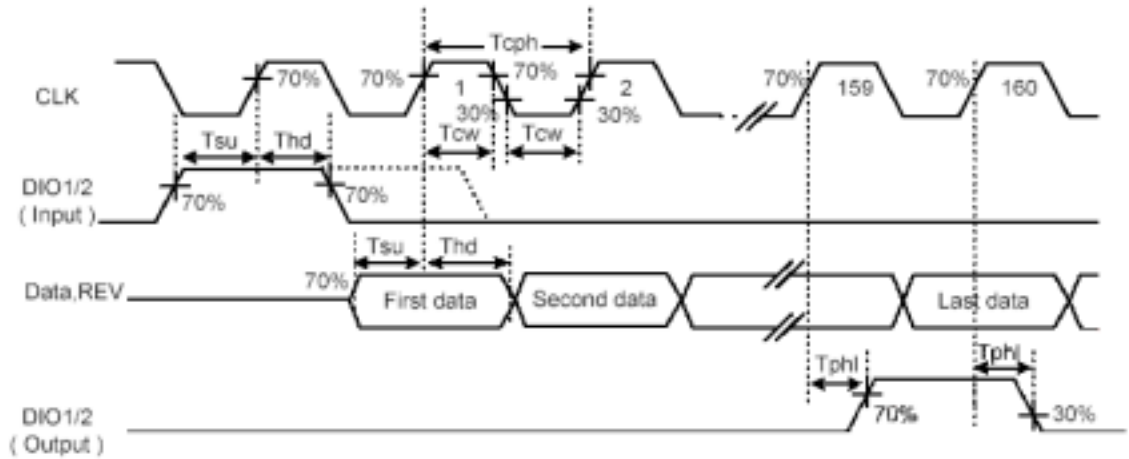

Operation Mode1

■ Timing Diagram 2

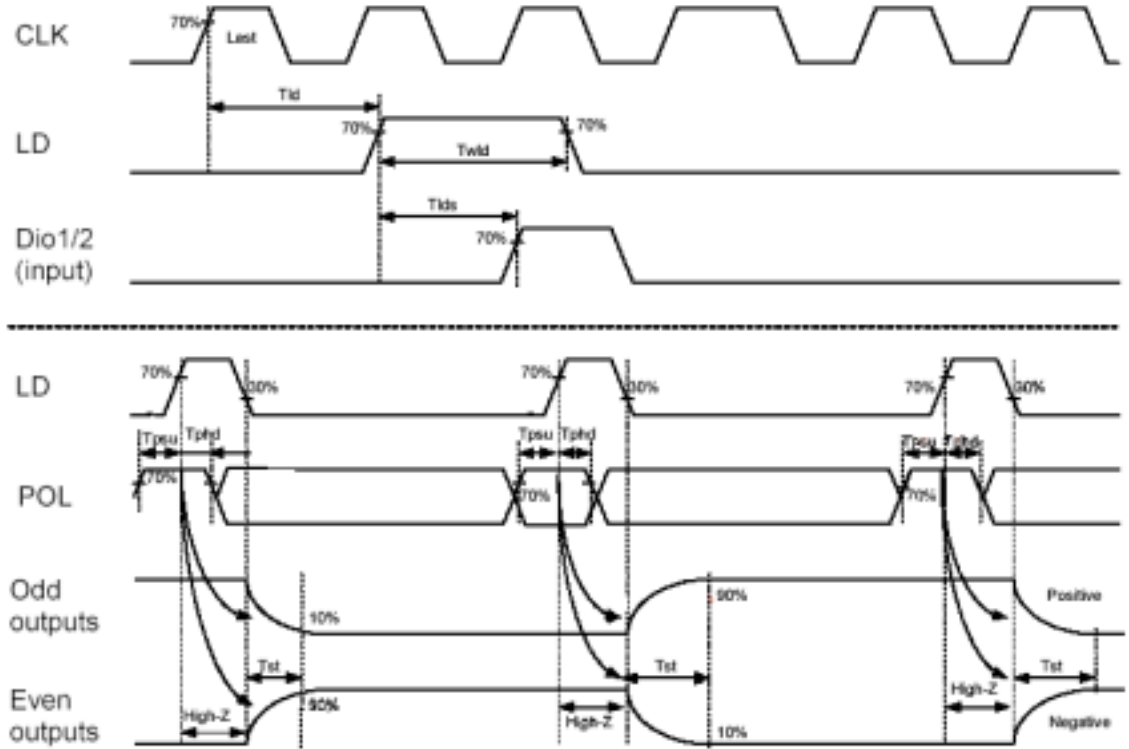

Operation Mode2

Document Title	HSD090IF41-A Product Information	Page No.	20/27
Document No.		Revision	1.0

### 6.5 Power Sequence

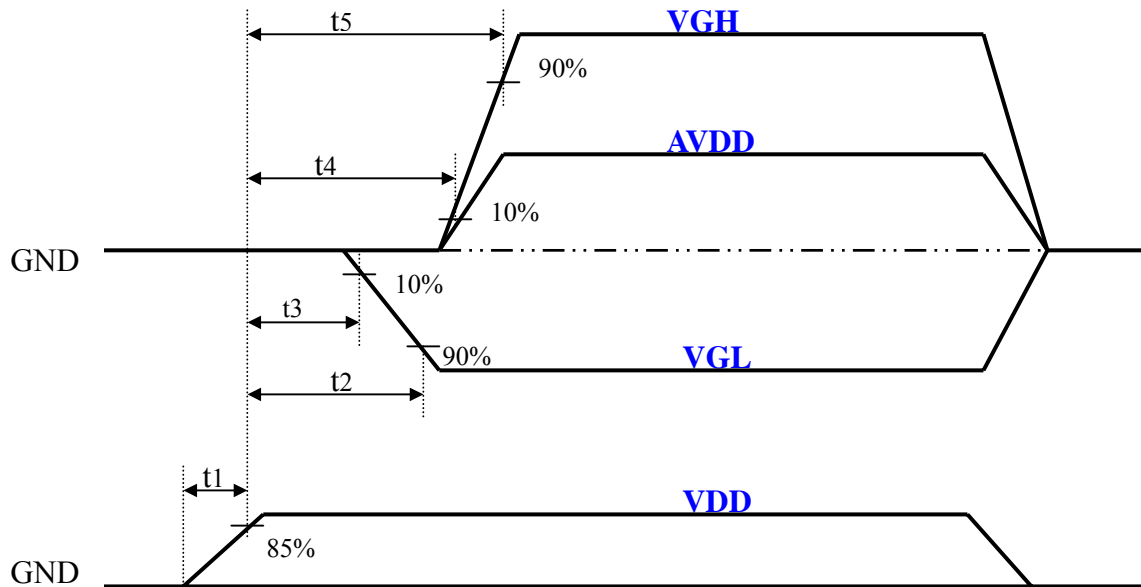

#### Power Sequence

Power Sequence: VDD -> VGL-> AVDD -> VGH  
 $t1 < 10\text{ms}$   
 $t3 < t4$   
 $t2, t5 \leq 40\text{ms}$ .

Note Apply the lamp voltage within the LCD operation range. When the back-light turns on before the LCD operation or the LCD turns off before the back-light turns off, the display may momentarily become white.

Document Title	HSD090IF41-A Product Information	Page No.	21/27
Document No.		Revision	1.0

### 7.0 Reliability test items

No.	Item	Conditions	Remark
1	High Temperature Storage	Ta=+70°C, 240hrs	
2	Low Temperature Storage	Ta=-20°C, 240hrs	
3	High Temperature Operation	Ta=+60°C, 240hrs	
4	Low Temperature Operation	Ta=-10°C, 240hrs	
5	High Temperature and High Humidity (operation)	Ta=+60°C, 90%RH, 240hrs	
6	Thermal Cycling Test (non operation)	-20°C(30min)→ +70°C(30min), 200cycles	
7	Electrostatic Discharge	±200V,200pF(0Ω) 1 time/each terminal	
8	Vibration	Random: 1.04Grms,10~500Hz, X/Y/Z 30min/each direction	
		Sweep sine: 1.5G,5~500Hz, X/Y/Z 30min/each direction	
9	Shock	100G,6ms, ±X, ±Y, ±Z 3 time for each direction	
10	Vibration (with carton)	Random: 1.04Grms,10~500Hz, X/Y/Z 45min/each direction	
		Fixed 5Hz,1.5G X/Y/Z 45min/each direction	
11	Drop (with carton)	Height: 60cm 1 corner, 3 edges, 6 surfaces	

Note: There are no display functional NG issue occurred. All the cosmetic specification is judged before the reliability stress.

Document Title	HSD090IF41-A Product Information	Page No.	22/27
Document No.		Revision	1.0

**8.0 OUTLINE DIMENSION**

Unit : mm

**8.1 Outline Dimension**

**8.1.1 Front view**

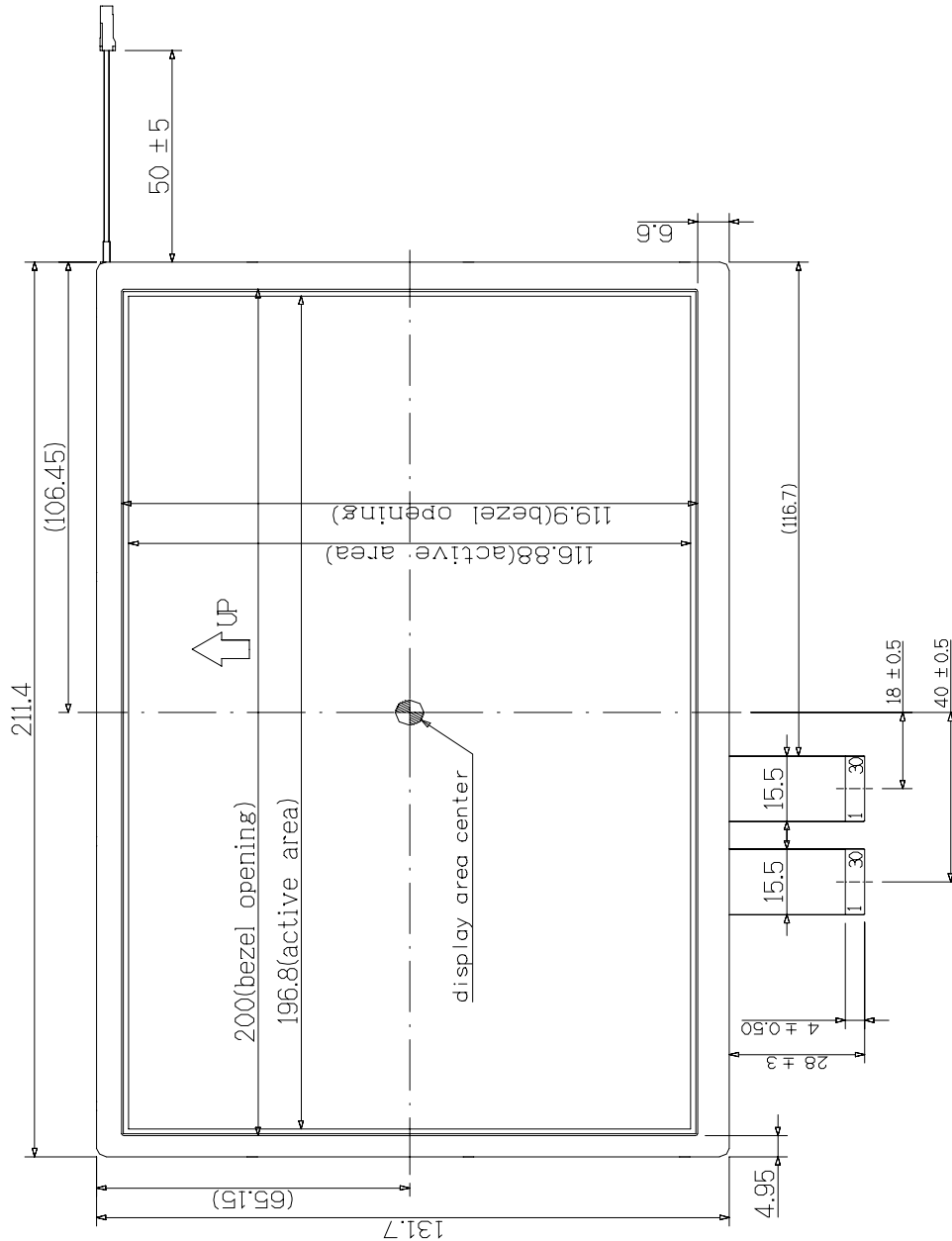

Document Title	HSD090IF41-A Product Information	Page No.	23/27
Document No.		Revision	1.0

**8.1.2 Back View**

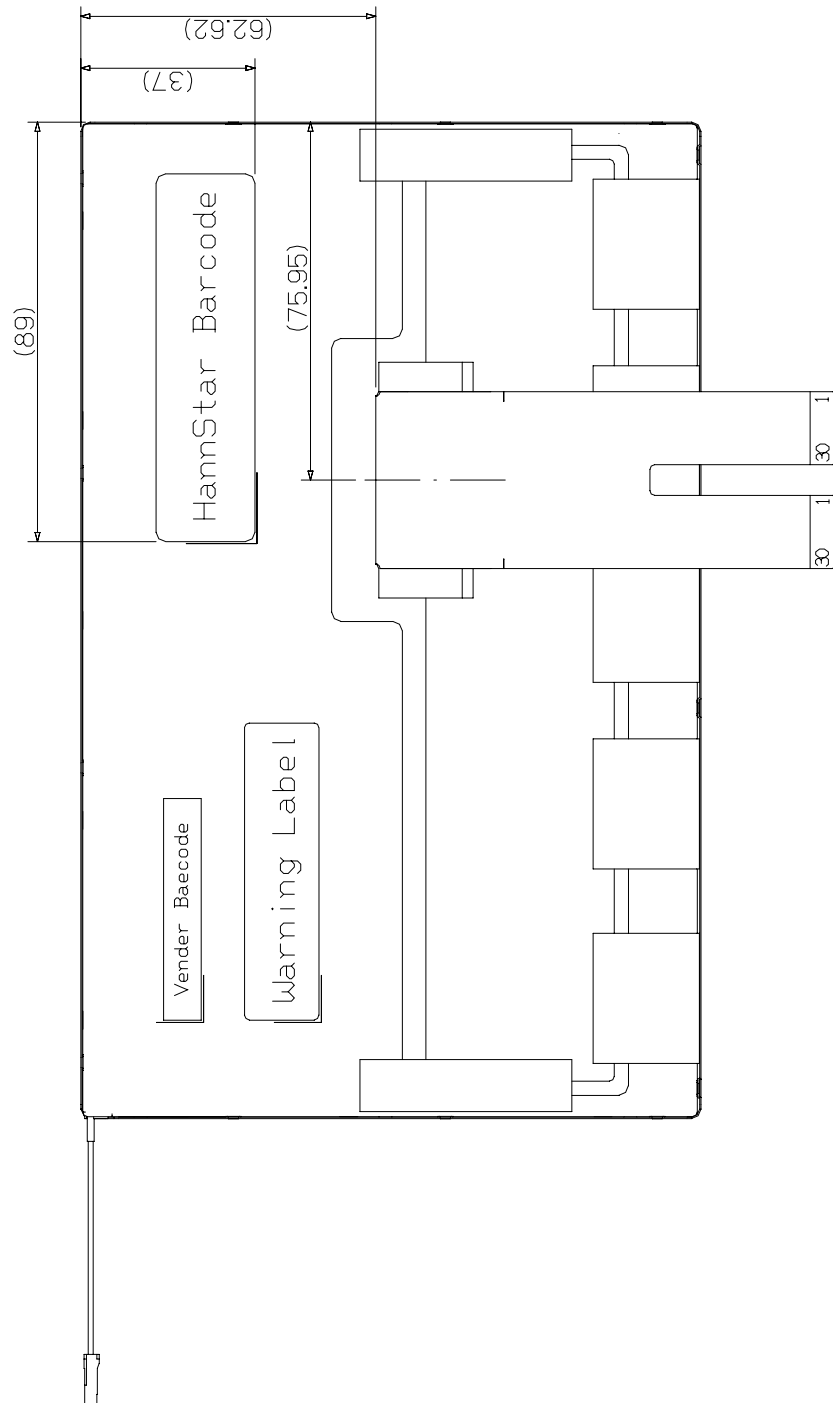

Document Title	HSD090IF41-A Product Information	Page No.	24/27
Document No.		Revision	1.0

## 9.0 LOT MARK

### 9.1 Lot Mark

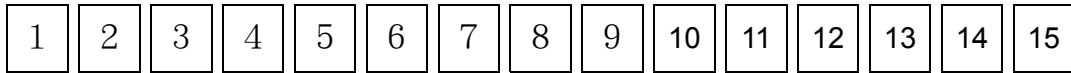

code 1,2,3,4,5,6: HannStar internal flow control code.

code 7: production location.

code 8: production year.

code 9: production month.

code 10,11,12,13,14,15: serial number.

#### Note (1) Production Year

Year	1999	2000	2001	2002	2003	2004	2005	2006	2007	2008
Mark	9	0	1	2	3	4	5	6	7	8

#### Note (2) Production Month

Month	Jan.	Feb.	Mar.	Apr.	May.	Jun.	Jul.	Aug.	Sep.	Oct.	Nov.	Dec.
Mark	1	2	3	4	5	6	7	8	9	A	B	C

### 9.2 Location of Lot Mark

(1) The label is attached to the backside of the LCD module.

(2) This is subject to change without prior notice.

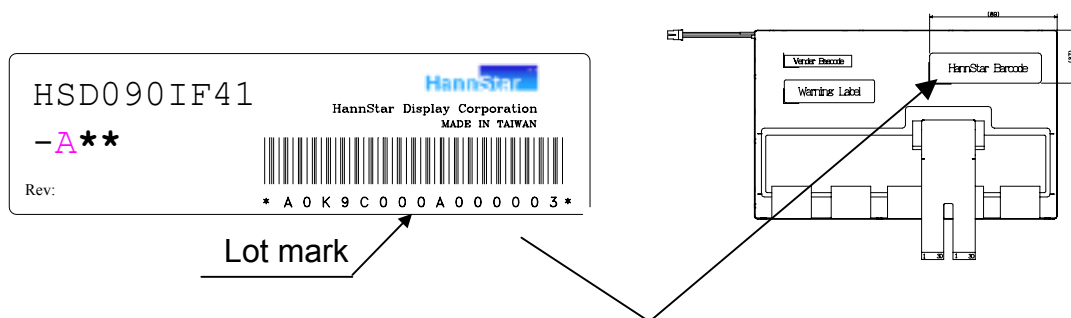



Document Title	HSD090IF41-A Product Information	Page No.	25/27
Document No.		Revision	1.0

## 10.0 PACKAGE SPECIFICATION

### 10.1 packing form

- (1) Package quantity in one carton: 24 pieces.
- (2) Carton size: 460±3 mm X 555±3 mm X 58±3 mm.
- (3) For domestic transportation only.

### 10.2 packing assembly drawings

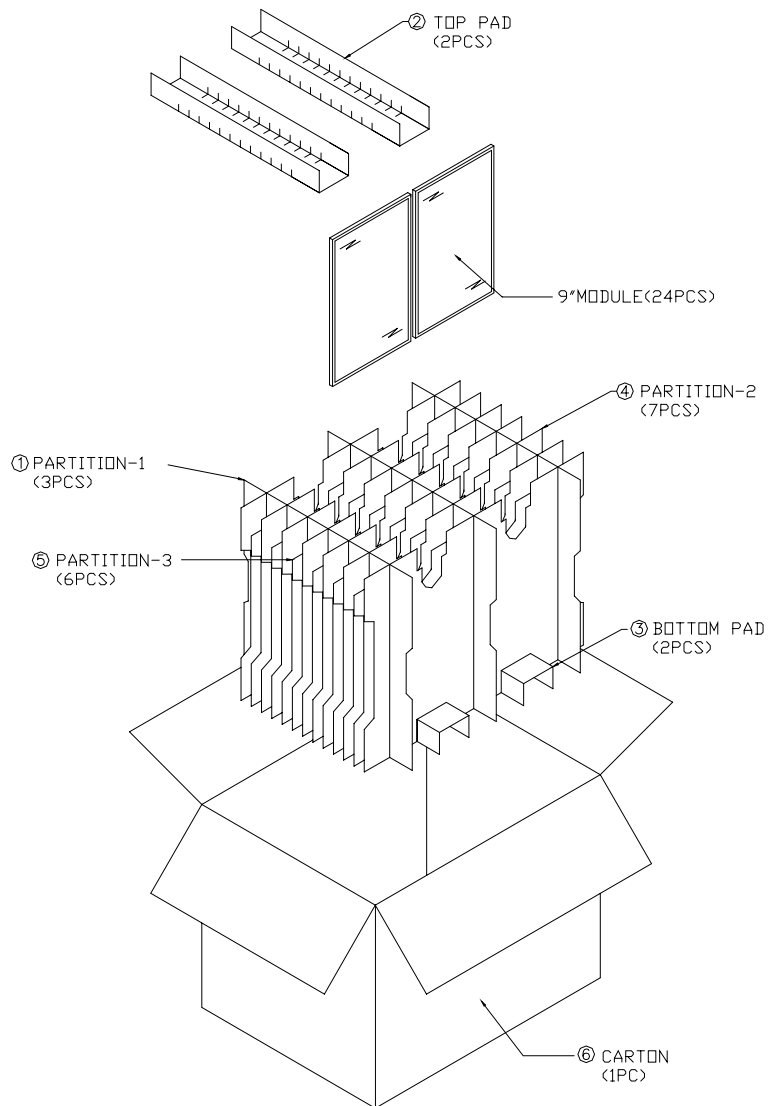

Document Title	HSD090IF41-A Product Information	Page No.	26/27
Document No.		Revision	1.0

## 11.0 GENERAL PRECAUTION

### 11.1 Use Restriction

This product is not authorized for use in life supporting systems, aircraft navigation control systems, military systems and any other application where performance failure could be life-threatening or otherwise catastrophic.

### 11.2 Disassembling or Modification

Do not disassemble or modify the module. It may damage sensitive parts inside LCD module, and may cause scratches or dust on the display. HannStar does not warrant the module, if customers disassemble or modify the module.

### 11.3 Breakage of LCD Panel

- (1) If LCD panel is broken and liquid crystal spills out, do not ingest or inhale liquid crystal, and do not contact liquid crystal with skin.
- (2) If liquid crystal contacts mouth or eyes, rinse out with water immediately.
- (3) If liquid crystal contacts skin or cloths, wash it off immediately with alcohol and rinse thoroughly with water.
- (4) Handle carefully with chips of glass that may cause injury, when the glass is broken.

### 11.4 Electric Shock

- (1) Disconnect power supply before handling LCD module.
- (2) Do not pull or fold the CCFL cable.
- (3) Do not touch the parts inside LCD modules and the fluorescent lamp's connector cable in order to prevent electric shock.

### 11.5 Absolute Maximum Ratings and Power Protection Circuit

- (1) Do not exceed the absolute maximum rating values, such as the supply voltage variation, input voltage variation, variation in parts' parameters, environmental temperature, etc., otherwise LCD module may be damaged.
- (2) Please do not leave LCD module in the environment of high humidity and high temperature for a long time.
- (3) It's recommended to employing protection circuit for power supply.

### 11.6 Operation

- (1) Do not touch, push or rub the polarizer with anything harder than HB pencil lead.
- (2) Use fingerstalls of soft gloves in order to keep clean display quality, when personshandle the LCD module for incoming inspection or assembly.
- (3) When the surface is dusty, please wipe gently with absorbent cotton or other soft material.
- (4) Wipe off saliva or water drops as soon as possible. If saliva or water drops contact with polarizer for a long time, they may causes deformation or color fading.



Document Title	HSD090IF41-A Product Information	Page No.	27/27
Document No.		Revision	1.0

- (5) When cleaning the adhesives, please use absorbent cotton wetted with a little petroleum benzine or other adequate solvent.

### 11.7 Mechanism

Please mount LCD module by using mounting holes arranged in four corners tightly.

### 11.8 Static Electricity

- (1) Protection film must remove very slowly from the surface of LCD module to prevent from electrostatic occurrence.
- (2) Because LCD module use CMOS-IC on circuit board and TFT-LCD panel, it is very weak to electrostatic discharge. Please be careful with electrostatic discharge. Persons who handle the module should be grounded through adequate methods.

### 11.9 Strong Light Exposure

The module shall not be exposed under strong light such as direct sunlight. Otherwise, display characteristics may be changed.

### 11.10 Disposal

When disposing LCD module, obey the local environmental regulations.